

# Humidity transmitter HM 110



## KEY POINTS

- Measuring range from 5 to 95%RH
- 0-10 V output, active, power supply 24 Vac/Vdc (3-4 wires) or 4-20 mA output, passive loop, power supply from 16 to 30 Vdc (2 wires)
- ABS V0 housing IP65 (duct or remote model) or IP20 (ambient model), with or without display
- "¼ turn" system mounting with wall-mount plate
- Housing with simplified mounting system

## FEATURES OF HOUSING

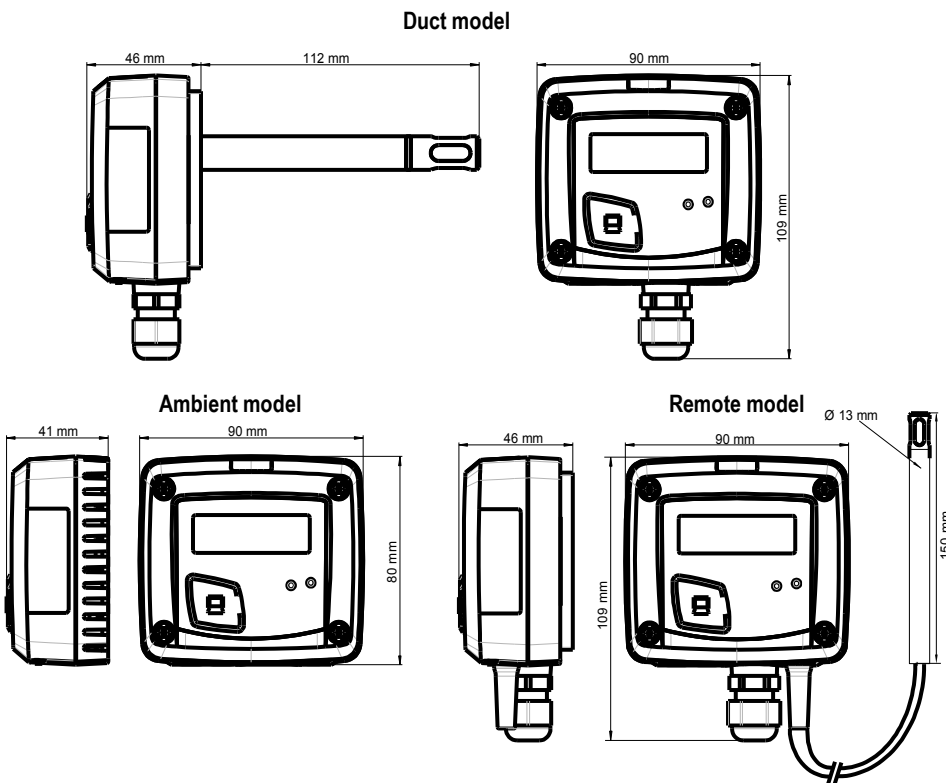

### Material

ABS V0 as per UL94

### Protection

IP65 (remote and duct models)  
IP20 (ambient model)

### Display

LCD 10 digits. Size : 50 x 17 mm

### Height of digits

Values : 10 mm  
Units : 5 mm

### Cable gland (remote and duct models)

For cables Ø 8 mm maximum

### Weight

145 g (ambient model) ; 223 g (remote and duct models)

**Cable of remote probes** : length 2 m and Ø 4.8 mm in silicone

## PART NUMBER

To order, just add the codes to complete the part number :

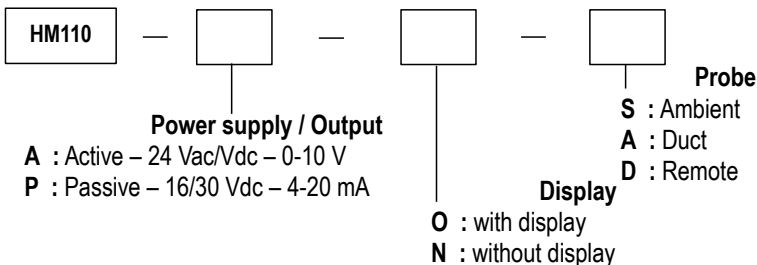

### Example : HM110 – ANS

Ambient humidity transmitter HM110, active 0-10 V, without display

## TECHNICAL FEATURE IN HUMIDITY

<b>Measuring range</b>	from 5 to 95% RH
<b>Accuracy**</b>	±1.5% RH (if 15°C ≤ T ≤ 25°C) on remote and duct models ±2% RH (if 15°C ≤ T ≤ 25°C) on ambient model
<b>Drift linked to temperature</b>	±0.04 x (T-20) %RH (if 15°C ≤ T ≤ 25°C)
<b>Unit of measurement</b>	% RH
<b>Response time</b>	1/e (63%) 4 s
<b>Type of sensor</b>	Capacitive on remote and duct models CMOS on ambient model
<b>Resolution</b>	0.1% RH
<b>Factory adjustment uncertainty</b>	±0.88% RH
<b>Type of fluid</b>	Air and neutral gases

\*\*All the accuracies indicated in this technical datasheet were stated in laboratory conditions, and can be guaranteed for measurements carried out in the same conditions, or carried out with calibration compensation.

As per NFX 15-113 and the *Charter 2000/2001 HYGROMETERS, GAL* (Guaranteed Accuracy Limit) which has been calculated with a coverage factor value of 2 is ±2.58%RH between 18 and 28°C on the measuring range from 3 to 98%RH. Sensor drift is less than 1%RH/year.

## TECHNICAL SPECIFICATIONS

<b>Output / Power supply</b>	- active sensor 0-10 V (power supply 24 Vac/Vdc ± 10%), 3-4 wires - passive loop sensor 4-20 mA (power supply 16/30 Vdc), 2 wires - maximum load : 500 Ohms (4-20 mA) - minimum load : 1 K Ohms (0-10 V)
<b>Consumption</b>	2 VA (0-10 V) or max. 22 mA (4-20 mA)
<b>Electromagnetical compatibility</b>	EN61326
<b>Electrical connection</b>	Screw terminal block for cables Ø0.05 to 2.5 mm <sup>2</sup>
<b>PC communication</b>	Kimo USB-mini Din cable
<b>Environment</b>	Air and neutral gases
<b>Operating temperature of the housing</b>	From 0 to 50 °C
<b>Operating temperature of the probe</b>	From -20 to +80 °C
<b>Storage temperature</b>	From -10 to +70 °C

## CONNECTIONS

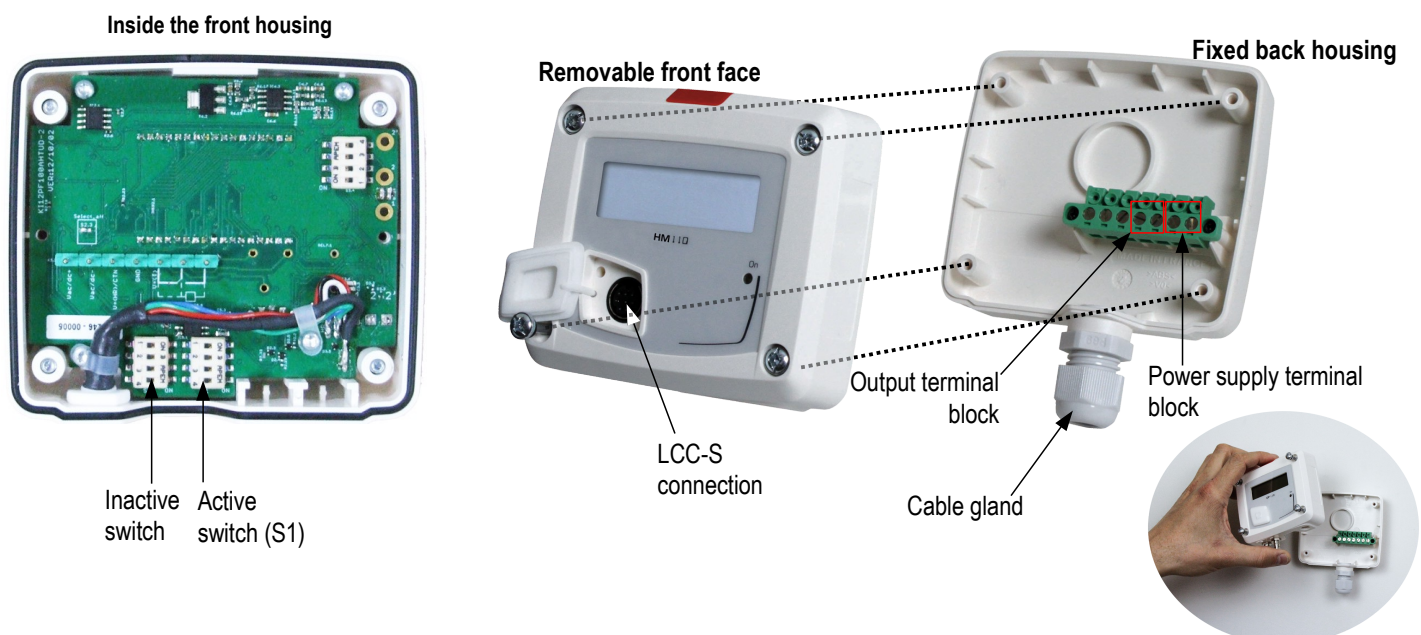

**ELECTRICAL CONNECTIONS – as per *NFC15-100* standard**

**!** This connection must be made by a qualified technician. To make the connection, the transmitter must not be energized.

For **HM110-AO** and **HM110-AN** models with **0-10 V** output – active :

**!** To make a 3-wire connection, before powering up the transmitter, please connect the output ground to the input ground. See drawing below.

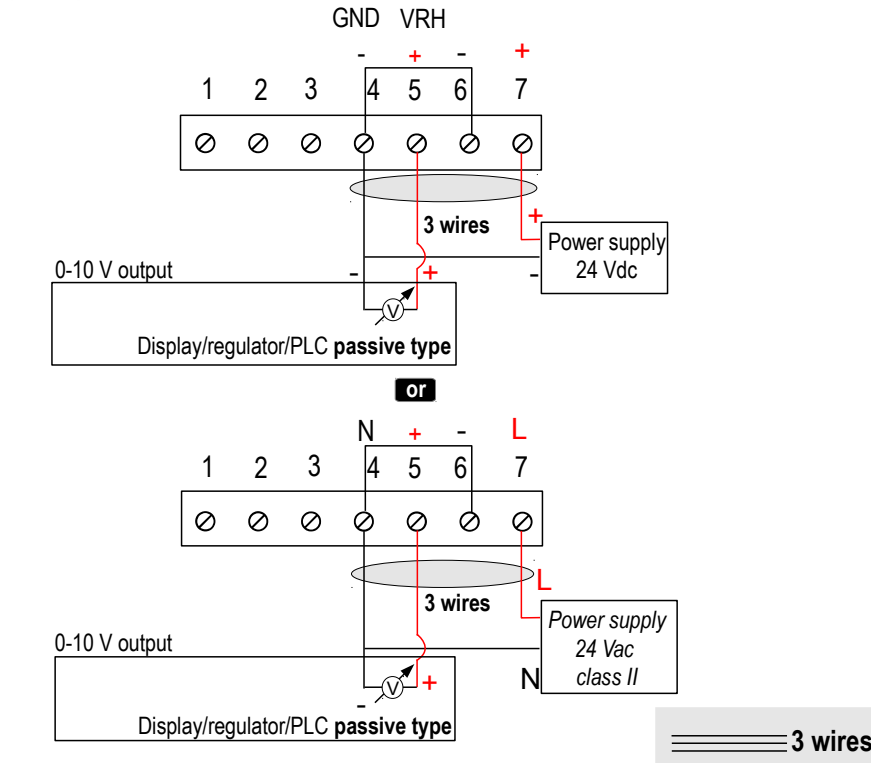
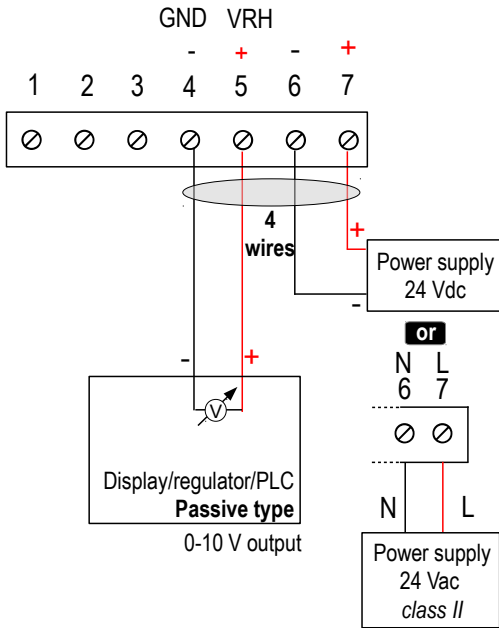

For **HM110-PO** and **HM110-PN** models with **4-20 mA** output – passive :

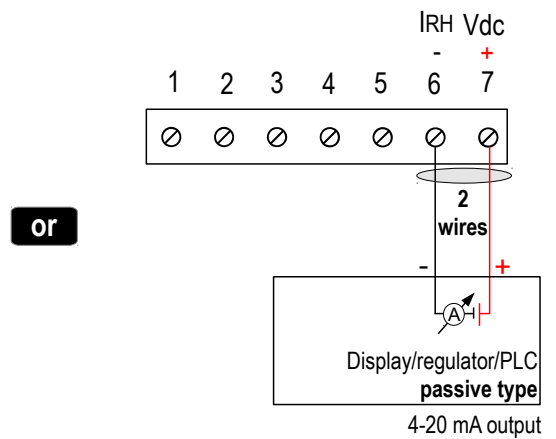
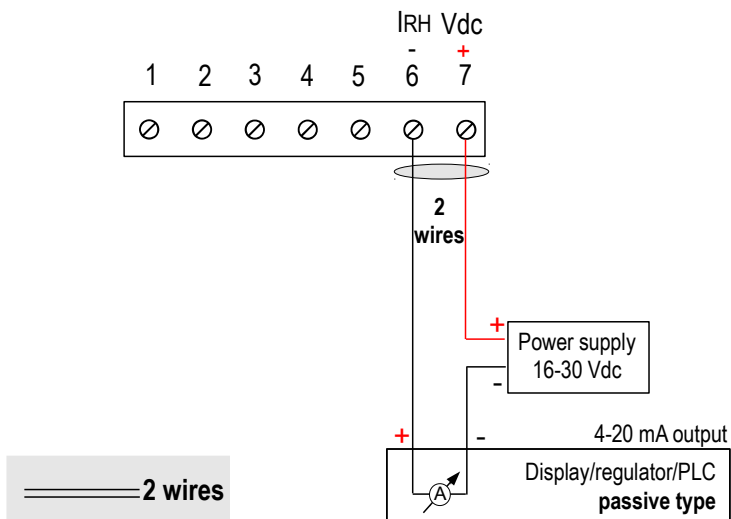

## CONFIGURATION VIA LCC-S SOFTWARE (option)

### An easy and friendly configuration with the software !

It is possible to configure an offset,...

Example : the instrument could be configured from 30 to 50%RH.

In order to compensate a possible drift of the transmitter, it is possible to add an offset to the displayed value by the HM110 instrument : it shows 48%RH, a standard instrument shows 45%RH. It is then possible, via the software, to integrate an offset of -3 to the displayed value by the HM110 instrument.

- To access the configuration via software :
  - Connect the cable of the LCC-S to the connection of the transmitter.
- Please refer to the user manual of the LCC 100 to make the configuration.

## MOUNTING

To mount the transmitter, mount the ABS plate on the wall (drilling :  $\varnothing 6$  mm, screws and pins are supplied).

Insert the transmitter on the fixing plate (see A on the drawing beside). Rotate the housing in clockwise direction until you hear a "click" which confirms that the transmitter is correctly installed.



**Ambient model does not have any mounting plate.**  
**4 fixing holes are present inside the back housing. Use them to install the transmitter on the required location.**

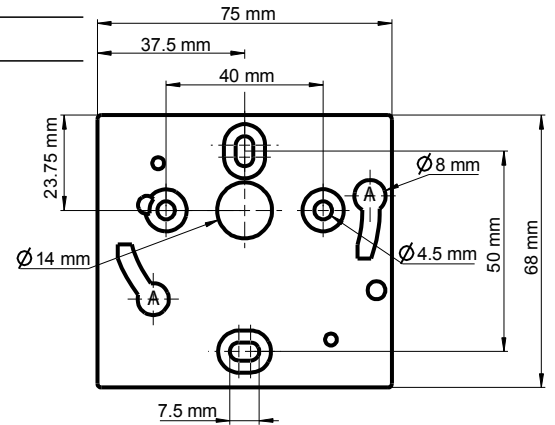

## MAINTENANCE

Please avoid any aggressive solvent. Please protect the transmitter and its probes from any cleaning product containing formalin, that may be used for cleaning rooms or ducts.

## OPTIONS AND ACCESSORIES

- **KIAL-100A** : Power supply class 2, 230 Vac input, 24 Vac output
- **LCC-S** : configuration software with USB cable
- Stainless steel sliding fittings
- PC cable gland
- ABS connection with connection gland
- Stainless steel connections
- Wall-mount plate for humidity remote probe

[www.kimo.fr](http://www.kimo.fr)

Distributed by :



**EXPORT DEPARTMENT**  
Tel : + 33. 1. 60. 06. 69. 25 - Fax : + 33. 1. 60. 06. 69. 29  
e-mail : [export@kimo.fr](mailto:export@kimo.fr)