

**JUMO GmbH & Co. KG**

Delivery address: Mackenrodtstraße 14  
36039 Fulda, Germany  
Postal address: 36035 Fulda, Germany  
Phone: +49 661 6003-0  
Fax: +49 661 6003-607  
E-mail: mail@jumo.net  
Internet: www.jumo.net

**JUMO Instrument Co. Ltd.**

JUMO House  
Temple Bank, Riverway  
Harlow, Essex CM20 2DY, UK  
Phone: +44 1279 635533  
Fax: +44 1279 635262  
E-mail: sales@jumo.co.uk  
Internet: www.jumo.co.uk

**JUMO Process Control, Inc.**

6733 Myers Road  
East Syracuse, NY 13057, USA  
Phone: 315-437-5866  
1-800-554-5866  
Fax: 315-437-5860  
E-mail: info.us@jumo.net  
Internet: www.jumousa.com



# JUMO AQUIS touch S

## Modular Multichannel Measuring Device for Liquid Analysis with Integrated Controller and Paperless Recorder

### Brief description

#### Measuring

The JUMO AQUIS touch S is the obvious choice as a central platform for displaying and processing pH-value, redox voltage, electrolytic conductivity, ultra-pure water resistance, temperature, disinfection measurands, (e.g. free chlorine, total chlorine, chlorine dioxide, ozone, hydrogen peroxide and peracetic acids and also flow rate). Pulse rate inputs (counters) are available for flow measurements. Universal inputs can be used to measure analog measurands via standard signals [0(4) to 20 mA or 0 to 10 V]. In total, the device can measure and manage up to 19 parameters simultaneously.

#### Control

Besides numerous simple alarm, limit value or time-controlled switching functions, up to four higher-order control loops can be defined in the JUMO AQUIS touch S at the same time. Tried and tested JUMO control algorithms are used for P, PI, PD, and PID control in these applications.

#### Display

A 5.5" TFT color screen with touch function serves to display all parameters as well as operate and setup the device. The plain text operation philosophy virtually eliminates the need for a manual. The operating language can be selected from among 15 languages that are already included in the device at the factory. The language library can be expanded to up to 30 languages via the PC setup program. It is also possible to display languages with Chinese or Cyrillic characters. As a result, the device is predestined for global use.

#### Record

A paperless recorder is integrated for data recording. Up to 8 analog measurands and 6 binary signals are recorded and displayed on the screen in their chronological sequence. Storage is tamper-proof and enables official recording obligations to be fulfilled. The data can be read via JUMO-PCC software or USB flash drive and evaluated using the PC evaluation software JUMO PCA3000.

#### Typical applications

The modular setup and open structure of the device permits a host of potential applications:

- Communal and industrial water treatment in wastewater treatment plants
- Process systems
- Drinking and bathing water monitoring
- Pharmaceutical water
- Food and beverage production (CIP/SIP plants)
- Gas scrubbers / air washers
- Cooling tower control
- Ion exchangers
- RO-units (reverse osmosis)
- Power stations and energy plants
- Fish breeding
- Desalination of seawater



**JUMO AQUIS touch S**  
Type 202581/...

### Special features

- Up to 4 analysis inputs in any combination for direct connection of sensors for liquid analysis
- Up to 15 further measuring signals can be connected either directly or via interface
- 2 pulse frequency inputs for flow measurement (max. 300 Hz or 10 kHz)
- Up to 17 switching outputs that are configurable as controller, switching, and alarm outputs
- Interfaces: USB host, USB device, Modbus, PROFIBUS-DP, and Ethernet
- Ethernet function: web server, alarm alerts via email, setup via PC, extraction of recorded measurement data
- Math and logic functions
- Integrated timers, wash timers, and calibration timers
- Service and operating hours counters
- Process-data recording with tamper-proof storage
- Luminous TFT color graphics screen with 5.5" screen diagonal, 320 × 240 pixel, QVGA, and 256 colors
- Intuitive operation via touchscreen
- Configurable user rights
- Freely configurable operator displays
- PC setup program
- Conductivity measurement for natural waters and TDS-measurement
- Switchable conductivity measuring ranges for CIP/SIP-plants in the beverage industry
- Compliance with pharmaceutical industry requirements to USP <645>
- Wall casing (protection type IP67) with ample connection space

**JUMO GmbH & Co. KG**  
 Delivery address: Mackenrodtstraße 14  
 36039 Fulda, Germany  
 Postal address: 36035 Fulda, Germany  
 Phone: +49 661 6003-0  
 Fax: +49 661 6003-607  
 E-mail: mail@jumo.net  
 Internet: www.jumo.net

**JUMO Instrument Co. Ltd.**  
 JUMO House  
 Temple Bank, Riverway  
 Harlow, Essex CM20 2DY, UK  
 Phone: +44 1279 635533  
 Fax: +44 1279 635262  
 E-mail: sales@jumo.co.uk  
 Internet: www.jumo.co.uk

**JUMO Process Control, Inc.**  
 6733 Myers Road  
 East Syracuse, NY 13057, USA  
 Phone: 315-437-5866  
 1-800-554-5866  
 Fax: 315-437-5860  
 E-mail: info.us@jumo.net  
 Internet: www.jumousa.com



## Block diagram

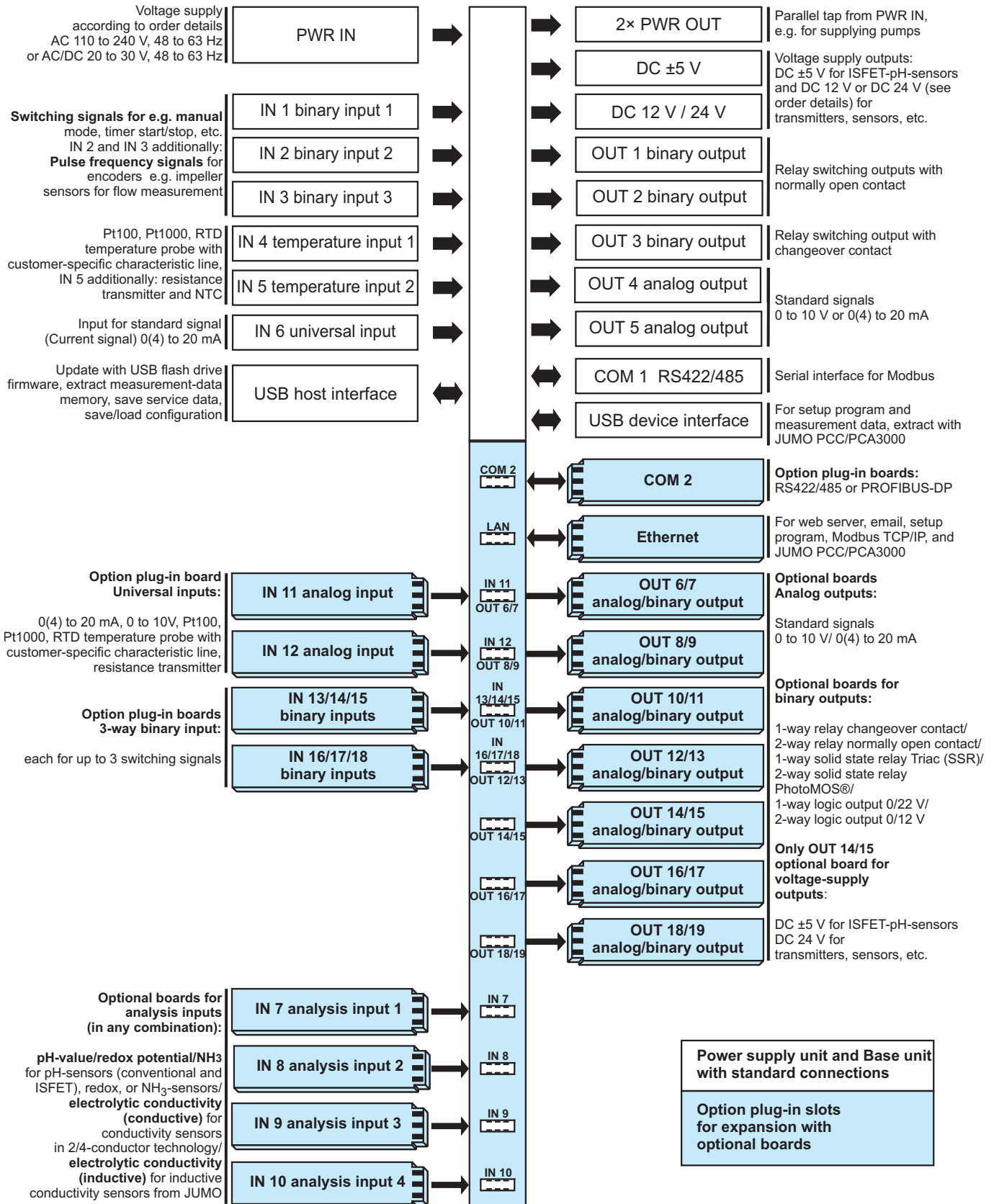



## Device setup

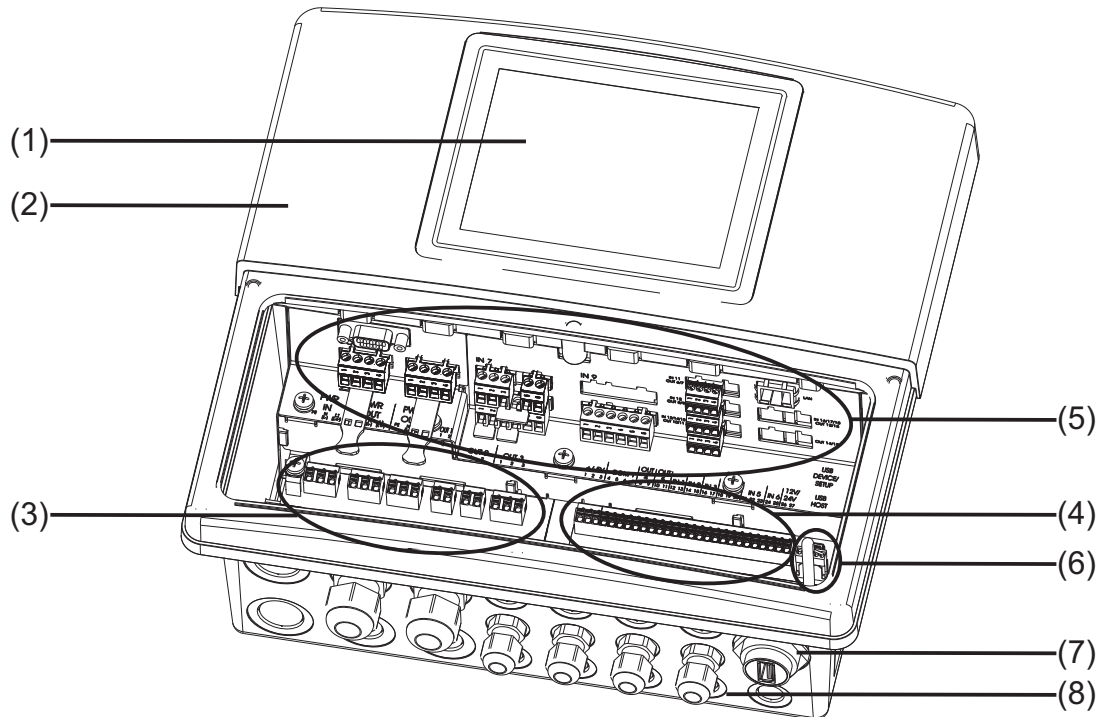

- |  |                                     |
|--|-------------------------------------|
| (1) TFT-touchscreen                          | (5) Optional slots                  |
| (2) Case (terminal compartment cover opened) | (6) USB interfaces                  |
| (3) Terminal blocks, power supply unit       | (7) USB host socket IP67 (optional) |
| (4) Terminal blocks, Base unit               | (8) Cable entries                   |

## Display and control elements

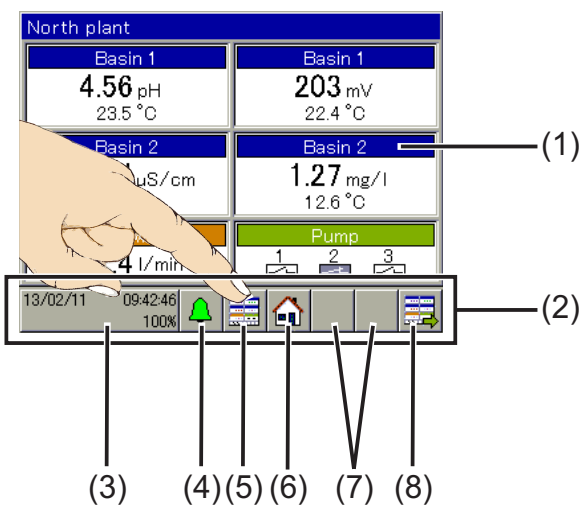

- |  |
|--|
| (1) Touchscreen  |
| (2) Toolbar with buttons for operation   |
| (3) "Device settings menu" button with: <ul style="list-style-type: none"> <li>• Display of date, time</li> <li>• Logged-in user (in the example: Master)</li> <li>• Remaining memory display in percent for recording function (in the example: 100 %)</li> </ul> |
| (4) "Alarm/event list" button  |
| (5) "Select operator display" button   |
| (6) "Home" button (back to main view)  |
| (7) Placeholder for context-sensitive buttons (assignment based on operator display concerned)   |
| (8) "Next operator display" button   |

**JUMO GmbH & Co. KG**  
 Delivery address: Mackenrodtstraße 14  
 36039 Fulda, Germany  
 Postal address: 36035 Fulda, Germany  
 Phone: +49 661 6003-0  
 Fax: +49 661 6003-607  
 E-mail: mail@jumo.net  
 Internet: www.jumo.net

**JUMO Instrument Co. Ltd.**  
 JUMO House  
 Temple Bank, Riverway  
 Harlow, Essex CM20 2DY, UK  
 Phone: +44 1279 635533  
 Fax: +44 1279 635262  
 E-mail: sales@jumo.co.uk  
 Internet: www.jumo.co.uk

**JUMO Process Control, Inc.**  
 6733 Myers Road  
 East Syracuse, NY 13057, USA  
 Phone: 315-437-5866  
 1-800-554-5866  
 Fax: 315-437-5860  
 E-mail: info.us@jumo.net  
 Internet: www.jumousa.com



## Description

### Operating concept

The JUMO AQUIS touch S is operated via the touch-display. Measured values, operating states, and diagrams of the individual functions are displayed and visualized on up to 16 operator displays. The device functions can be controlled using the buttons on the corresponding operator displays. Touching the navigation buttons selects the operator display to be shown. The operator displays are arranged in an operating loop and can be run in a loop via the "Next operator display" button and selected using the "Select operator display" button.

The "Device settings menu" button is for configuration and parameterization. A further menu for viewing pending alarms and an event protocol can be opened via the "Alarm/event list" button.

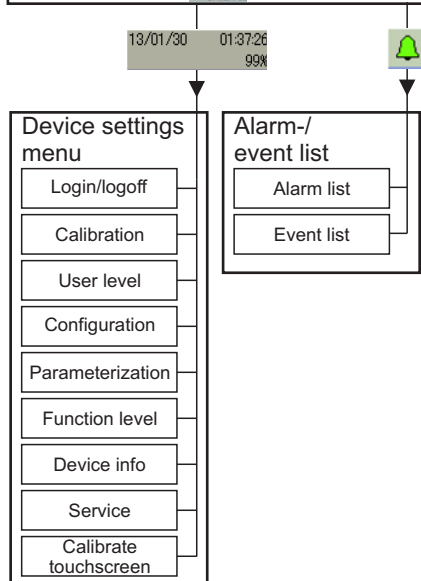
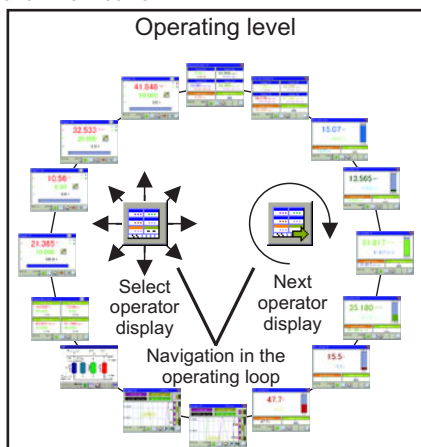

- Master: Complete device configuration permitted
- Service: Access for authorized service personnel
- User1/User2: Restricted user rights

The scope of the user rights, as well as passwords and user names can be edited via the PC setup program.

### Operating loop/operator displays

The operating loop comprises 2 overview screens and 6 individual screens as standard. Further operator displays are created by configuring controllers and recording groups, thereby provisioning controller screens and diagrams in the operating loop. The individual operator displays can be configured for showing selected measured values or binary signals and for defining headings.

### Overview screens

The overview screens are pooled displays of measured values and binary signal states. For the analog measurands, 2-part screens, or 4-part screens can be configured for displaying 2 or 4 display fields, each with a main and a secondary measured value. One additional value and up to 3 binary values can also be displayed in each overview screen. Headings of the display window and the display fields can be renamed. Input signals can be freely assigned to the display fields. One 4-part overview screen displays up to 9 analog and 3 binary signals.

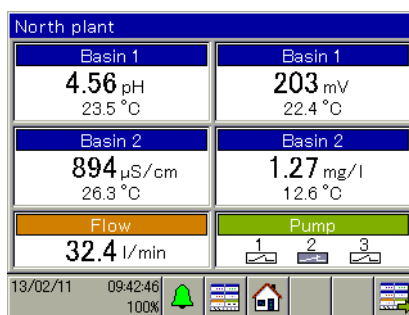

### Individual screens

The individual screens are large-scale displays of a main measured value with a secondary measured value. One additional value and 3 binary signals can also be displayed. The main value is visualized by a bar graph. Limit values for alarm functions of the measuring input concerned are displayed by marks on the bar graph.

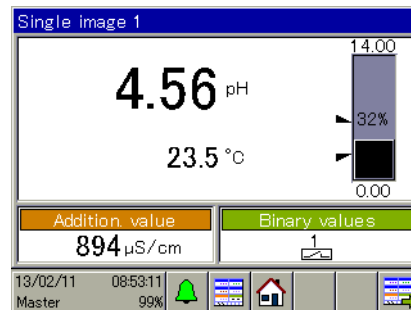

### Data monitor

This function is included in the standard version. The data monitor displays measurement data as a line recorder diagram with time stamp. There are 2 groups available. For each activated group, a diagram is displayed in the operating loop as long as the group concerned is configured. 4 analog channels and 3 binary channels can be displayed per group. The measurement data are stored in a ring buffer. The oldest measurement data are overwritten to allow measurement data recording to continue when the ring buffer is full.

### Recording function

This function equates to a conventional paperless recorder and is available as an extra code. It corresponds essentially to an expanded data monitor function with the following additional options:

- Display measurement data history (scroll diagram)
- Data retrieval via USB flash drive or JUMO PCC software

The measurement data histories can be retrieved via JUMO PCC software or alternatively via USB flash drive, and can be displayed, evaluated, and archived using the JUMO PCA3000 PC Evaluation Software.

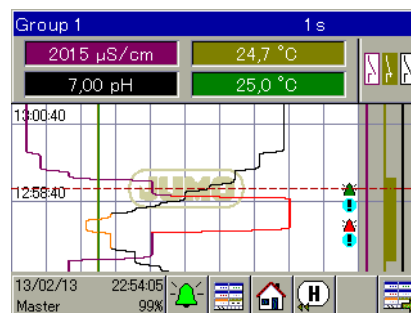

### User rights

The available operating and setting options depend on the user rights of the logged-in user. The device holds 4 user accounts.



**JUMO GmbH & Co. KG**

Delivery address: Mackenrodtstraße 14  
36039 Fulda, Germany  
Postal address: 36035 Fulda, Germany  
Phone: +49 661 6003-0  
Fax: +49 661 6003-607  
E-mail: mail@jumo.net  
Internet: www.jumo.net

**JUMO Instrument Co. Ltd.**

JUMO House  
Temple Bank, Riverway  
Harlow, Essex CM20 2DY, UK  
Phone: +44 1279 635533  
Fax: +44 1279 635262  
E-mail: sales@jumo.co.uk  
Internet: www.jumo.co.uk

**JUMO Process Control, Inc.**

6733 Myers Road  
East Syracuse, NY 13057, USA  
Phone: 315-437-5866  
1-800-554-5866  
Fax: 315-437-5860  
E-mail: info.us@jumo.net  
Internet: www.jumousa.com

**Process screen**

The PC setup program is able to create a customer-specific process screen in which a global overview of the plant process can be displayed. Once created, the process screen is transferred by the PC setup program to the JUMO AQUIS touch S, where it becomes part of the operating loop. Up to 50 objects (screens, digital displays, bar graphs, texts, etc.) can be used in the process screen. Typical for a process screen:

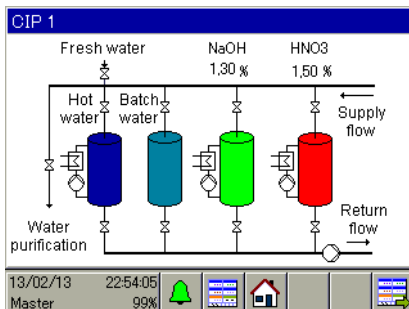
**User level**

A user level is a menu which the user can access quickly and simply in order to define certain parameters and configuration settings. A user-defined block of up to 25 settings can be selected via the PC setup program and stored at user level.

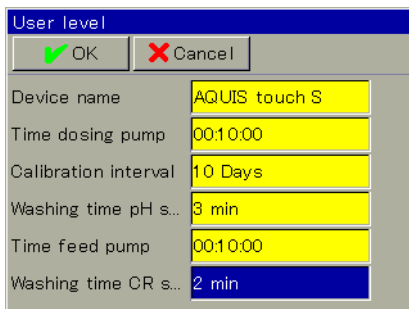
**Function level**

The "Function level" menu allows internal functions to be used and the status of these functions to be displayed. For example, counters can be reset or a wash operation started manually here.

**PC setup program**

The PC setup program enables the JUMO AQUIS touch S to be conveniently configured and parameterized using a PC. Data records can be created, edited, transmitted to the device and extracted in this way. The data can be saved and printed.

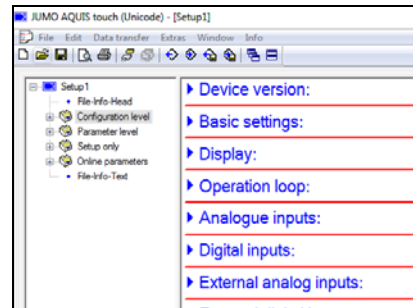
**Analysis inputs**

Four optional slots for analysis inputs can be flexibly equipped with optional boards for measuring pH-value, redox potential, NH<sub>3</sub>, and electrolytic conductivity (conductive/inductive). The conductivity measurement also covers TDS and ultra-pure water applications within its performance range of services.

A compensation for numerous influencing variables (e.g. temperature and pH-value) can be configured. This makes the JUMO AQUIS touch S the central measuring point for all analysis measurands in one process. The diverse range of connectable electrodes and sensors enable all process-relevant measurands to be recorded in a single device. In addition to analysis measurands, these measurands include physical measurands, such as temperature and flow rate, and also any measurand capable of being transferred as a pulse frequency signal or standard signal. Alarm functions ensure the monitoring of measured values for overrun and underrun of limit values. The limit values can be defined by the user.

**Analog inputs**

Besides the standard temperature measuring inputs (Pt100, Pt1000, resistance transmitters, NTC, etc.) and the universal input (0(4) to 20 mA) of the Base unit, additional analog inputs with optional boards can be made available. The optional analog inputs can be configured for RTD temperature probes, resistance transmitters, and voltage and current signals. This makes the JUMO AQUIS touch S extremely flexible to use for measuring numerous measurands. Here too, the user can configure alarm functions for monitoring measured values for overrun and underrun.

**Customer-specific linearization**

In addition to the standardized, factory-stored sensor characteristic lines, customer-specific linearization is also possible. This option allows any sensor characteristic lines to be entered. Programming is done via the PC setup program through a value table (up to 40 value pairs) or by inputting a 4th degree polynomial.

**Binary inputs**

The signals from 3 standard and up to 6 optional binary inputs (potential-free contacts and logic signals) can be used to trigger various internal functions, switchover of a parameter block or the start of autotuning, for example.

IN 2 and IN 3 enable the frequency of encoders to be measured in order to perform flow measurements using impeller sensors or monitor the rotational speed of pumps, for instance. There are 2 measuring ranges available, depending on how the measuring principle in the flow function is configured:

- 3 to 300 Hz (periodic time measurement)
- 300 Hz to 10 kHz (pulse counting)

**External inputs**

Bus technologies enable a further 8 analog and 8 binary inputs to be employed for signal transmission with bus users.

**Analog outputs**

The analog outputs are freely scalable (current, voltage). They can be used to output controller outputs, setpoint values, math results, and the analog input signals (e.g. actual value).

Besides the 2 standard analog outputs of the Base unit, up to 7 more with optional boards can be retrofitted.

**Binary outputs**

Binary outputs are switching and logic outputs.

Binary outputs enable the output of alarms, limit value contacts, logic results and controller signals.

Three binary outputs (OUT 1 to 3 relay) are provided as standard. A maximum of 17 binary outputs can be achieved in the device by means of optional boards.

The following variants are available as optional boards:

- 1-way output relay (changeover contact)
- 2-way output relay (normally open contact)
- 1-way output solid state relay Triac
- 2-way output solid state relay PhotoMOS® (wear-free control, e.g. of metering pumps)

**JUMO GmbH & Co. KG**  
 Delivery address: Mackenrodtstraße 14  
 36039 Fulda, Germany  
 Postal address: 36035 Fulda, Germany  
 Phone: +49 661 6003-0  
 Fax: +49 661 6003-607  
 E-mail: mail@jumo.net  
 Internet: www.jumo.net

**JUMO Instrument Co. Ltd.**  
 JUMO House  
 Temple Bank, Riverway  
 Harlow, Essex CM20 2DY, UK  
 Phone: +44 1279 635533  
 Fax: +44 1279 635262  
 E-mail: sales@jumo.co.uk  
 Internet: www.jumo.co.uk

**JUMO Process Control, Inc.**  
 6733 Myers Road  
 East Syracuse, NY 13057, USA  
 Phone: 315-437-5866  
 1-800-554-5866  
 Fax: 315-437-5860  
 E-mail: info.us@jumo.net  
 Internet: www.jumousa.com



**Limit value monitoring**

In addition to the alarm functions of the measuring inputs, there are 8 limit value monitors, each with 4 selectable switching functions (min. alarm, max. alarm, alarm window, inverted alarm window) available. The limit value can be permanently configured. This function enables the monitoring of any analog values. The violation of a limit value can trigger alarms, event list entries, or switching functions. The diagrams below show the limit value functions concerned.

**Min. alarm**

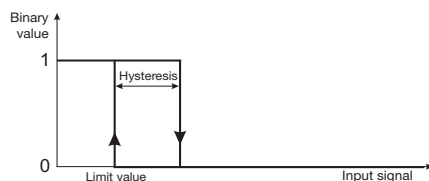

**Max. alarm**

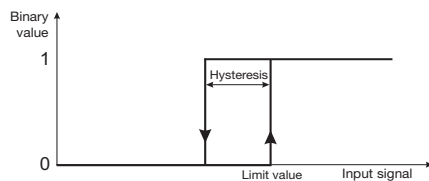

**Alarm window**

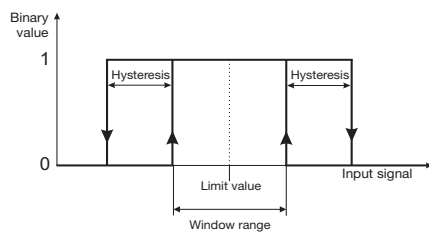

**Inverted alarm window**

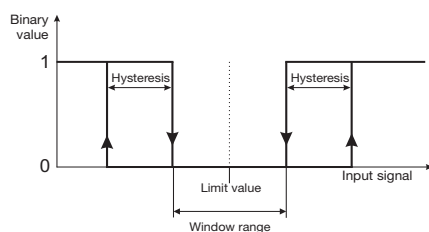

**Controller**

Up to 4 PID controllers can be activated at the same time. Each analog input signal (analysis size, temperature, standard signal, etc.) can be freely assigned to one of the controller channels. Feed-forward control, parameter block switchover, and a coarse/fine control function enable especially stable controller behavior. The controller outputs can be configured as continuous output (output level as standard signal), pulse length output (output level as pulse length), or pulse frequency output (output level as pulse frequency).

**Pulse length output**

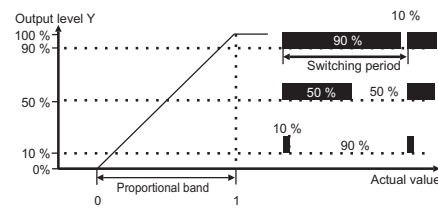

**Pulse frequency output**

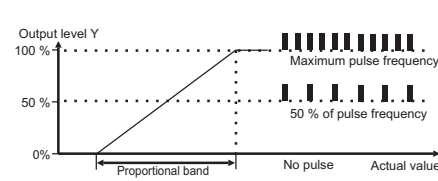

between its two parameter blocks in order to adapt the controller behavior if certain process conditions change. Parameter blocks can be toggled separately for each controller channel.

**Autotuning**

The autotuning function also enables a user who is not a control technology expert to adapt the controller to the control path. During this process, the reaction of the control path to the changes in the actuating variable is evaluated. The step response method is implemented in the controller channels of the JUMO AQUIS touch S to allow autotuning.

**Controller individual screens**

The controller functions are visualized in detail here. Data such as actual value, setpoint value, and output level are displayed. The controller can be used in this view (manual output ratio, setpoint value input).

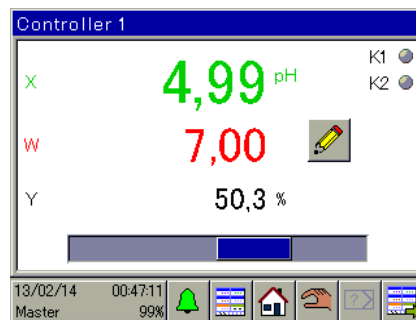

**Math and logic function**

The math and logic module enables analog channels to be associated with one another, and also analog channels to be associated with counters and binary inputs. Numerous operators are available for the formulae. The JUMO PC setup program can be used to create formulae with basic arithmetic operations, root functions, power functions, logarithm functions, angle functions, and many other functions. Operators AND, OR, NOT, XOR, and edge detections are available for logic printouts. The math and logic module can be configured solely via the PC setup program. This function is available as an option.

**Flow rate**

Two flow measurement functions can be configured. Flow rates can be measured on the basis of the pulse signals at IN 2 or IN 3 and/or of an analog input signal. The measured flow rate can be integrated via the "Total quantity" function. In this way, the liquid volume that has passed over the measuring point is cumulated over a configurable period.

**Controller overview screen**

If at least 2 controller channels are configured, an overview of all controllers with the most important data is displayed in the operating loop.

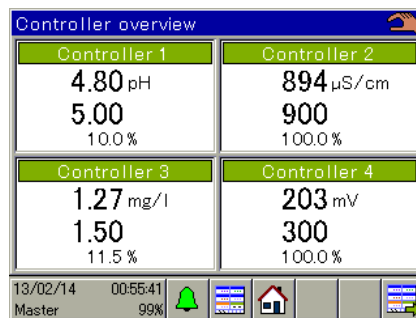

**Counter**

Four counters can be used to count activation operations or operating hours of binary functions such as alarms, binary inputs, wash timers, etc. This function is intended primarily for monitoring maintenance intervals.

**Controller parameters**

Two parameter blocks can be saved for each of the 4 controller channels. Each parameter block has 25 parameters for adapting the controller to the conditions of the process concerned. Each controller can be toggled

**JUMO GmbH & Co. KG**

Delivery address: Mackenrodtstraße 14  
36039 Fulda, Germany  
Postal address: 36035 Fulda, Germany  
Phone: +49 661 6003-0  
Fax: +49 661 6003-607  
E-mail: mail@jumo.net  
Internet: www.jumo.net

**JUMO Instrument Co. Ltd.**

JUMO House  
Temple Bank, Riverway  
Harlow, Essex CM20 2DY, UK  
Phone: +44 1279 635533  
Fax: +44 1279 635262  
E-mail: sales@jumo.co.uk  
Internet: www.jumo.co.uk

**JUMO Process Control, Inc.**

6733 Myers Road  
East Syracuse, NY 13057, USA  
Phone: 315-437-5866  
1-800-554-5866  
Fax: 315-437-5860  
E-mail: info.us@jumo.net  
Internet: www.jumousa.com

**Timers**

Two timer functions are included. They can be configured either as timers or time switches. Configured as a timer, the functions act like a time relay. The timer is controlled for starting, resetting and stopping via binary signals. A timer can also be stopped, or its start delayed, by the tolerance band function. The tolerance band is the deviation of a measured value from a predefined reference. If the configured deviation is exceeded, the timer concerned stops.

The chronological sequence of the timer signal can be influenced by the settings "timer time", "timer start runup time," and "timer end time" in such a manner that a typical time relay functions (e.g. response delay or fallback delay) can be achieved.

The time switch function corresponds to a week timer. Up to 4 activation and deactivation times can be set for each weekday.

**Wash timer**

Two wash timers are used for the regular cleaning of electrodes. Certain recurring functions are triggered at pre-configurable intervals. Wash timers can, for example, control binary outputs in order to activate a cleaning process in the plant. By cleaning sensors on a regular basis, optimal measuring certainty can be guaranteed.

**Calibration timer**

The calibration timer function reminds the operator to re-calibrate the sensors. Corresponding alarms and event list entries can be individually configured.

**Calibration logbook**

Analog inputs IN 6 to IN 12 are covered by a calibration logbook, in which all successfully completed calibration processes are recorded along with the date, time, and numerous other details. An overview of the calibration history on the analysis sensors is therefore available at all times.

**USB interfaces**

There are two types of USB interface — a host interface and a device interface. A USB flash drive can be connected to the host interface. Measurement data, configuration data, and service data can thus be saved. Additionally, configurations can be uploaded from the flash drive to the device and device software updates can be run. The device interface serves, in combination with a standard USB cable, to operate the PC setup program and to retrieve measurement data for the optional recording function via the JUMO PCC software. Both

USB interfaces are located next to the connection terminals in the base board. The host interface can optionally be attached to a USB host socket (see order details) on the case next to the cable entries, allowing it to be used without opening the case.

**Serial interfaces RS422/485**

The JUMO AQUIS touch S has a standard RS422/485 interface with Modbus RTU protocol (slave). A further interface can be retrofitted as an optional board. Serial interfaces are used to integrate the device into an automation network. This allows the JUMO AQUIS touch S to communicate with a SCADA system or other Modbus master devices.

**PROFIBUS-DP interface**

The PROFIBUS-DP interface can be used to integrate the JUMO AQUIS touch S into a fieldbus system operating according to the PROFIBUS-DP standard. An application-specific GSD file, via which the JUMO AQUIS touch S is integrated into the fieldbus system, is generated by means of the project engineering tool supplied (GSD generator; GSD = basic device data (*Gerätstammdaten*)).

**Ethernet interface**

The JUMO AQUIS touch S can be integrated into a LAN via the optional Ethernet interface. This enables the device to communicate with all PCs in the LAN concerned. The PC setup program and PCC communication software can be accessed from these PCs using the JUMO programs. The Ethernet interface permits use of the web server, email, and Modbus TCP/IP functions.

**Web server (online visualization)**

HTML documents, which can be created using a conventional HTML editor, can be stored in the JUMO AQUIS touch S using the PC setup program. These documents can contain texts, graphics, and JavaScript code. Analog and binary values of the JUMO AQUIS touch S can be displayed via JavaScript. The result is a website which can be retrieved over the Internet or LAN and displayed via a PC using a conventional web browser. On this website, the user can now see a clear display of the plant or the process, including measured values and operating states. A "Standard online visualization" function is stored at the factory. A PC with Microsoft® Windows® operating system and Silverlight® installed is required to use this function.

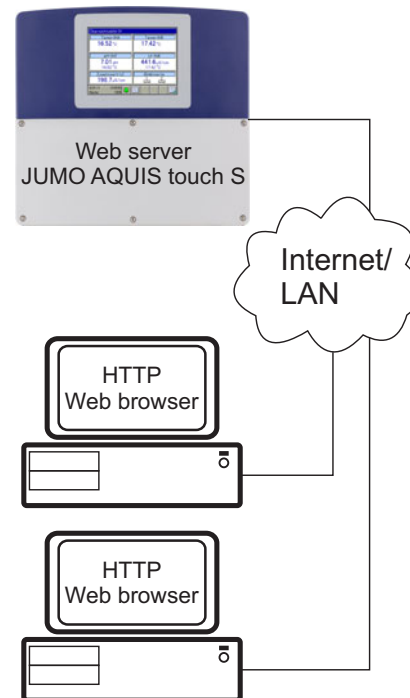
**Alarm/event list**

**The alarm list** reports currently pending errors. Possible alarm messages include calibration alarms or alarms triggered by input signals. Once the error sources are eliminated, alarms disappear automatically.

**The event list** stores and reports events, such as the appearance and disappearance of alarms, voltage supply failures, calibrations, etc. However, event list entries can also be configured in the functions of the JUMO AQUIS touch S.

**Email/SMS text message**

The JUMO AQUIS touch S can be configured for the event-controlled dispatch of email messages. This enables maintenance personnel to be notified about the presence of alarms, for example (also via transmission as SMS in the email/SMS gateway of a cellular phone provider).

**JUMO GmbH & Co. KG**  
 Delivery address: Mackenrodtstraße 14  
 36039 Fulda, Germany  
 Postal address: 36035 Fulda, Germany  
 Phone: +49 661 6003-0  
 Fax: +49 661 6003-607  
 E-mail: mail@jumo.net  
 Internet: www.jumo.net

**JUMO Instrument Co. Ltd.**  
 JUMO House  
 Temple Bank, Riverway  
 Harlow, Essex CM20 2DY, UK  
 Phone: +44 1279 635533  
 Fax: +44 1279 635262  
 E-mail: sales@jumo.co.uk  
 Internet: www.jumo.co.uk

**JUMO Process Control, Inc.**  
 6733 Myers Road  
 East Syracuse, NY 13057, USA  
 Phone: 315-437-5866  
 1-800-554-5866  
 Fax: 315-437-5860  
 E-mail: info.us@jumo.net  
 Internet: www.jumousa.com



## Technical data

### Analog inputs, Base unit

#### Temperature measuring input (IN 4)

Probe/signal type	Connection type	Measuring range	Measuring accuracy	Ambient temperature influence
Pt100 DIN EN 60751	2-wire/3-wire	-200 to +850 °C	≤ 0.05 % of MR <sup>a</sup>	≤ 50 ppm/K
Pt1000 DIN EN 60751	2-wire/3-wire	-200 to +850 °C	≤ 0.1 % of MR <sup>a</sup>	≤ 50 ppm/K
RTD temperature probe with customer-specific characteristic line <sup>b</sup>				
Up to 400 Ω	2-wire/3-wire	0 to 400 Ω	≤ 0.5 % of R <sub>max</sub> <sup>c</sup>	≤ 100 ppm/K
Up to 4000 Ω	2-wire/3-wire	0 to 4000 Ω	≤ 0.5 % of R <sub>max</sub> <sup>c</sup>	≤ 100 ppm/K
Sensor lead resistance	Maximum 30 Ω per line with 3-wire circuit.			
Lead compensation	Not required for 3-wire circuit. With a 2-wire circuit, a lead calibration can be executed at the respective input by means of an actual correction value using the "Offset" setting.			

<sup>a</sup> MR: measuring range scope..

<sup>b</sup> Customer-specific linearization can be used to enter a sensor characteristic line.

<sup>c</sup> R<sub>max</sub>: maximum resistance across the measuring range (400 Ω or 4000 Ω)

#### Temperature measuring input (IN 5)

Probe/signal type	Connection type	Measuring range	Measuring accuracy	Ambient temperature influence
Pt100 DIN EN 60751	2-wire/3-wire	-200 to +850 °C	≤ 0.05 % of MR <sup>a</sup>	≤ 50 ppm/K
Pt1000 DIN EN 60751	2-wire/3-wire	-200 to +850 °C	≤ 0.1 % of MR <sup>a</sup>	≤ 50 ppm/K
Resistance transmitter	3 wire	0 to 100 kΩ	0.5 % of R <sub>Tot</sub> <sup>b</sup>	≤ 100 ppm/K
RTD temperature probe with customer-specific characteristic line <sup>c</sup>				
Up to 400 Ω	2-wire/3-wire	0 to 400 Ω	≤ 0.5 % of R <sub>max</sub> <sup>d</sup>	≤ 100 ppm/K
Up to 4000 Ω	2-wire/3-wire	0 to 4000 Ω		
Up to 100 kΩ	2-wire/3-wire	0 to 100 kΩ		
NTC 8k55	2-wire/3-wire	0 to 150 °C	≤ 0.1 % of R <sub>max</sub> <sup>d</sup>	≤ 100 ppm/K
NTC 22k	2-wire/3-wire	0 to 150 °C		
Sensor lead resistance	Maximum 30 Ω per line with 3-wire circuit.			
Lead compensation	Not required for 3-wire circuit. With a 2-wire circuit, a lead calibration can be executed at the respective input by means of an actual correction value using the "Offset" setting.			

<sup>a</sup> MR: measuring range scope.

<sup>b</sup> R<sub>Tot</sub>: total resistance of the resistance transmitter.

<sup>c</sup> Customer-specific linearization can be used to enter a sensor characteristic line.

<sup>d</sup> R<sub>max</sub>: maximum resistance across the measuring range (400 Ω, 4000 Ω or 100 kΩ).

#### Universal input (IN 6)

Signal type	Measuring range	Measuring accuracy	Ambient temperature influence
Current signal	0(4) to 20 mA	0.1 % of MR <sup>a</sup>	100 ppm/K

<sup>a</sup> MR: measuring range scope.



**JUMO GmbH & Co. KG**  
 Delivery address: Mackenrodtstraße 14  
 36039 Fulda, Germany  
 Postal address: 36035 Fulda, Germany  
 Phone: +49 661 6003-0  
 Fax: +49 661 6003-607  
 E-mail: mail@jumo.net  
 Internet: www.jumo.net

**JUMO Instrument Co. Ltd.**  
 JUMO House  
 Temple Bank, Riverway  
 Harlow, Essex CM20 2DY, UK  
 Phone: +44 1279 635533  
 Fax: +44 1279 635262  
 E-mail: sales@jumo.co.uk  
 Internet: www.jumo.co.uk

**JUMO Process Control, Inc.**  
 6733 Myers Road  
 East Syracuse, NY 13057, USA  
 Phone: 315-437-5866  
 1-800-554-5866  
 Fax: 315-437-5860  
 E-mail: info.us@jumo.net  
 Internet: www.jumousa.com



**Analog inputs, optional boards**

**Universal input (IN 11, IN 12)**

Probe/signal type	Connection type	Measuring range	Measuring accuracy	Ambient temperature influence
Pt100 DIN EN 60751	2-wire/3-wire	-200 to +850 °C	≤ 0.05 % of MR <sup>a</sup>	≤ 50 ppm/K
Pt1000 DIN EN 60751	2-wire/3-wire	-200 to +850 °C	≤ 0.1 % of MR <sup>a</sup>	≤ 50 ppm/K
Resistance transmitter	3 wire	100 to 4000 Ω	0.5 % of R <sub>Tot</sub> <sup>b</sup>	≤ 100 ppm/K
RTD temperature probe with customer-specific characteristic line <sup>c</sup>				
Up to 400 Ω	2-wire/3-wire	0 to 400 Ω	≤ 0.5 % of R <sub>max</sub> <sup>d</sup>	≤ 100 ppm/K
Up to 4000 Ω	2-wire/3-wire	0 to 4000 Ω	≤ 0.5 % of R <sub>max</sub> <sup>d</sup>	≤ 100 ppm/K
Voltage signal	-	0 to 10 V	0.2 % of MB <sup>a</sup>	100 ppm/K
Current signal	-	0(4) to 20 mA	0.1 % of MB <sup>a</sup>	100 ppm/K
Sensor lead resistance <sup>e</sup>	Maximum 30 Ω per line with 3-wire circuit.			
Lead calibration <sup>e</sup>	Not required for 3-wire circuit. With a 2-wire circuit, a lead calibration can be executed at the respective input by means of an actual correction value using the "Offset" setting.			

- <sup>a</sup> MR: measuring range scope..
- <sup>b</sup> R<sub>Tot</sub>: total resistance of the resistance transmitter.
- <sup>c</sup> Customer-specific linearization can be used to enter a sensor characteristic line.
- <sup>d</sup> R<sub>max</sub>: maximum resistance across the measuring range (400 Ω or 4000 Ω)
- <sup>e</sup> Specification does not apply for standard signals.

**Analysis input: pH/Redox/NH<sub>3</sub>**

Measurand	Measuring range	Temperature compensation	Measuring accuracy	Ambient temperature influence
pH-Wert (standard electrode)	-2 to 16 pH	-10 to +150 °C	≤ 0.3 % of MR <sup>a</sup>	0.2 %/10 K
pH-Wert (ISFET electrode)	-2 to 16 pH	None		
Redox voltage	-1500 to +1500 mV	None		
NH <sub>3</sub> (ammonia)	0 to 20000 ppm	-10 to +150 °C		

- <sup>a</sup> MR: measuring range scope..

**Analysis input: CR (conductivity, conductive)**

Units	Display ranges <sup>a</sup>	Temperature compensation	Cell constant	Measuring range change-over <sup>b</sup>	Measuring accuracy	Ambient temperature influence
μS/cm mS/cm kΩ × cm MΩ × cm	0.00 to 9.9999 00.00 to 99.999 000.00 to 999.99 0000.0 to 9999.9 00000 to 99999	TC linear, natural water DIN EN 27888, natural water with expanded range, TDS <sup>c</sup> , ASTM D-1125-95 for neutral (NaCl), acid (HCl) and alkali (NaOH) impurities	2-wire: 0.01 to 10 cm <sup>-1</sup>  4-wire: 0.5 to 1 cm <sup>-1</sup>	Four measuring ranges Configurable	≤ 0.6 % of MR <sup>d</sup> + 0.3 μS × cell constants (C)	0.2 %/10 K

- <sup>a</sup> The display range is scalable. The decimal place is freely configurable. An automatic decimal place can also be set.
- <sup>b</sup> Up to 4 different measuring ranges with separate display range limits, units, temperature compensation processes and alarm functions can be configured. The respective active measuring range is selected via binary signals.
- <sup>c</sup> TDS (Total Dissolved Solids)
- <sup>d</sup> MR: measuring range scope.

**JUMO GmbH & Co. KG**  
 Delivery address: Mackenrodtstraße 14  
 36039 Fulda, Germany  
 Postal address: 36035 Fulda, Germany  
 Phone: +49 661 6003-0  
 Fax: +49 661 6003-607  
 E-mail: mail@jumo.net  
 Internet: www.jumo.net

**JUMO Instrument Co. Ltd.**  
 JUMO House  
 Temple Bank, Riverway  
 Harlow, Essex CM20 2DY, UK  
 Phone: +44 1279 635533  
 Fax: +44 1279 635262  
 E-mail: sales@jumo.co.uk  
 Internet: www.jumo.co.uk

**JUMO Process Control, Inc.**  
 6733 Myers Road  
 East Syracuse, NY 13057, USA  
 Phone: 315-437-5866  
 1-800-554-5866  
 Fax: 315-437-5860  
 E-mail: info.us@jumo.net  
 Internet: www.jumousa.com



**Analysis input: Ci (conductivity, inductive)**

Units	Measuring/display ranges <sup>a</sup>	Temperature compensation	Cell constant	Measuring range change-over <sup>b</sup>	Measuring accuracy	Ambient temperature influence
µS/cm mS/cm	0.00 to 9.9999 00.00 to 99.999 000.00 to 999.99 0000.0 to 9999.9 00000 to 99999	TC linear, <sup>c</sup> TC curve, natural water, natural water with expanded temperature range, NaOH 0 to 12 %, NaOH 25 to 50 %, HNO <sub>3</sub> 0 to 25 %, HNO <sub>3</sub> 36 to 82 %, H <sub>2</sub> SO <sub>4</sub> 0 to 28 %, H <sub>2</sub> SO <sub>4</sub> 36 to 85 %, H <sub>2</sub> SO <sub>4</sub> 92 to 99 %, HCl 0 to 18 %, HCl 22 to 44 %	4.00 to 8.00 cm <sup>-1</sup>	Four measuring ranges Configurable	For 0 to 999 µS/cm: 1.5 % of MRE <sup>d</sup>  For 1 to 500 mS/cm: 1 % of MRE <sup>d</sup>  For 500.1 to 2000 mS/cm 1.5 % of MRE <sup>d</sup>	0.1 %/K

- <sup>a</sup> The display range is scalable. The decimal place is freely configurable. An automatic decimal place can also be set.
- <sup>b</sup> Up to 4 different measuring ranges with separate display range limits, units, temperature compensation processes, and alarm functions can be configured. The respective currently active measuring range is selected via binary signals.
- <sup>c</sup> TC: temperature coefficient.
- <sup>d</sup> MRE: measuring range end value.

**Temperature compensations**

Compensation type	Compensation range
Linearer TC <sup>a</sup>	-50 to +250 °C
TC curve	-50 to +250 °C
TDS	-50 to +250 °C
Natural water according to DIN EN 27888	0 to 36 °C
Natural water with expanded temperature range <sup>b</sup>	0 to 100 °C
ASTM D-1125-95 (neutral, alkali and acid impurities)	0 to 100 °C
NaOH 0 to 12 %	0 to 90 °C
NaOH 25 to 50 %	10 to 90 °C
HNO <sub>3</sub> 0 to 25 %	0 to 80 °C
HNO <sub>3</sub> 36 to 82 %	-20 to +65 °C
H <sub>2</sub> SO <sub>4</sub> 0 to 28 %	-17 to +104 °C
H <sub>2</sub> SO <sub>4</sub> 36 to 85 %	-17 to +115 °C
H <sub>2</sub> SO <sub>4</sub> 92 to 99 %	-17 to +115 °C
HCL 0 to 18 %	10 to 65 °C
HCL 22 to 44 %	-20 to +65 °C

- <sup>a</sup> TC: temperature coefficient.
- <sup>b</sup> The temperature compensation "natural water with expanded temperature range" extends beyond the standardized temperature thresholds of DIN EN 27888.

**Measuring circuit monitoring, Base unit**

Inputs	Underrange/overrange	Short circuit/sensor break	Open circuit
Temperature input	Yes	Yes	Yes
Universal input (current signal)	Yes	Yes <sup>a</sup>	Yes <sup>a</sup>

- <sup>a</sup> With current and voltage signals, error detection depends on the input configuration.

**JUMO GmbH & Co. KG**  
 Delivery address: Mackenrodtstraße 14  
 36039 Fulda, Germany  
 Postal address: 36035 Fulda, Germany  
 Phone: +49 661 6003-0  
 Fax: +49 661 6003-607  
 E-mail: mail@jumo.net  
 Internet: www.jumo.net

**JUMO Instrument Co. Ltd.**  
 JUMO House  
 Temple Bank, Riverway  
 Harlow, Essex CM20 2DY, UK  
 Phone: +44 1279 635533  
 Fax: +44 1279 635262  
 E-mail: sales@jumo.co.uk  
 Internet: www.jumo.co.uk

**JUMO Process Control, Inc.**  
 6733 Myers Road  
 East Syracuse, NY 13057, USA  
 Phone: 315-437-5866  
 1-800-554-5866  
 Fax: 315-437-5860  
 E-mail: info.us@jumo.net  
 Internet: www.jumousa.com



**Measuring circuit monitoring, optional boards**

Input/sensor	Underrange/overrange	Short circuit/ sensor break	Open circuit	Special features
pH-value (glass electrode)	Yes	Configurable Impedance measure- ment <sup>a</sup>	Configurable Impedance measure- ment <sup>a</sup>	-
pH-value (ISFET)	Yes	No	Underrange/overrange	-
Conductivity, conductive	Yes	Underrange/overrange	Configurable	Detection of deposits (4-wire circuit)
Conductivity, inductive	Yes	No	Yes	-
Universal input for connection of: voltage/current signal, RTD temper- ature probe	Yes	Yes <sup>b</sup>	Yes <sup>b</sup>	-
Universal input for connection of: re- sistance transmitter	No	Yes	Yes	-

- <sup>a</sup> The standard underrange/overrange monitoring function is always active.  
 Monitoring via impedance measurement can be optionally activated. Since this depends on marginal parameters, the following points must be observed:
- Impedance measurements are possible only with glass-based sensors.
  - Sensors must be connected directly to an analysis input for pH/Redox/NH<sub>3</sub> on the device.
  - Impedance converters must not be installed in the measuring circuit.
  - The maximum admissible cable length between sensor and transmitter is 10 m.
  - Fluid resistances have a direct impact on the measurement result. It is therefore advisable to activate the impedance measurement in liquids from a minimum conductivity of approx. 100 µS/cm.
- <sup>b</sup> With current and voltage signals, error detection depends on the signal scaling. 0 V or 0 mA may be interpreted as sensor errors.

**Analog outputs, Base unit and optional boards**

Signal type	Signal range	Admissible load resistance	Accuracy	Ambient tempera- ture influence
Voltage signal	0 to 10 V	> 500 Ω	≤ 0.25 %	≤ 100 ppm / K
Current signal	0/4 to 20 mA	< 450 Ω	≤ 0.25 %	≤ 100 ppm / K

**Binary inputs, Base unit**

Description	Input frequency rang- es	Min. pulse duration		Signal type	Switching thresh- olds <sup>a</sup>	
		On	Off		On	Off
IN 1 <sup>b</sup>	≤ 1 Hz	≥ 300 ms	≥ 300 ms	Configurable as: potential-free contact or external voltage source	> 8 V	< 5 V
IN 2 <sup>b,c</sup>	3 to 300 Hz	≥ 30 µs	≥ 30 µs		> 1.8 mA	< 1.2 mA
IN 3 <sup>b,c</sup>	300 Hz ... 10 kHz	≥ 30 µs	≥ 30 µs			

- <sup>a</sup> This specification is relevant only if the external voltage source is selected under the "Contact" item in the configuration.  
<sup>b</sup> All binary inputs IN 1 to 3 are suitable for connecting proximity switches. Recommended types are: Wachendorff P2C2B1208NO3A2 and Balluff BES M12EG-PSC80F-BP03.  
<sup>c</sup> Binary inputs IN 2 and IN 3 can be used for impeller flow sensors (water meters) or magnetic-inductive flow meters, for example. The input frequency depends on the configured measurement principle in the flow function.

**Binary inputs, optional boards**

Max. number of retrofittable bina- ry inputs	Max. pulse frequency	Min. pulse duration		Signal type
		On	Off	
Max. 2 optional boards with 3 binary inputs each	≤ 1 Hz	≥ 300 ms	≥ 300 ms	Potential-free contact

**Binary outputs, power supply unit board**

Description	Switching output	Ampacity at ohmic load	Contact life <sup>a</sup>
OUT 1	Relay, normally open contact	3 A at AC 250 V	150,000 switching operations
OUT 2	Relay, normally open contact		
OUT 3	Relay, changeover con- tact		

<sup>a</sup> The maximum ampacity of the contacts must not be exceeded.

**JUMO GmbH & Co. KG**  
 Delivery address: Mackenrodtstraße 14  
 36039 Fulda, Germany  
 Postal address: 36035 Fulda, Germany  
 Phone: +49 661 6003-0  
 Fax: +49 661 6003-607  
 E-mail: mail@jumo.net  
 Internet: www.jumo.net

**JUMO Instrument Co. Ltd.**  
 JUMO House  
 Temple Bank, Riverway  
 Harlow, Essex CM20 2DY, UK  
 Phone: +44 1279 635533  
 Fax: +44 1279 635262  
 E-mail: sales@jumo.co.uk  
 Internet: www.jumo.co.uk

**JUMO Process Control, Inc.**  
 6733 Myers Road  
 East Syracuse, NY 13057, USA  
 Phone: 315-437-5866  
 1-800-554-5866  
 Fax: 315-437-5860  
 E-mail: info.us@jumo.net  
 Internet: www.jumousa.com



**Binary outputs, optional boards**

Optional card	Switching output	Max. current	Contact life <sup>a</sup>	Special features
Relay output 2-way Normally open contacts	2 normally open contacts <sup>b</sup>	3 A at AC 250 V <sup>c</sup>	150,000 switching operations	-
Relay output 1-way Changeover contact	1 changeover contact			-
Solid state relay Triac	Switching output with Triac (protected by varistor) <sup>d</sup>	1 A at AC 230 V <sup>c</sup>	Wear-free	-
Solid state relay PhotoMOS®e	Switching output with PhotoMOS®e	200 mA at DC 50 V or AC 35 V <sup>c</sup>	Wear-free	Not short-circuit-proof Max. voltage DC 50 V AC 35 V
Logic output 0/12 V	High/low signal	20 mA <sup>f</sup>	Wear-free	-
Logic output 0/22 V	High/low signal	30 mA <sup>e</sup>	Wear-free	-

- <sup>a</sup> The maximum ampacity of the contacts must not be exceeded.
- <sup>b</sup> Combining a mains voltage circuit with a protective low voltage circuit on a 2-way normally open contact option is not admissible.
- <sup>c</sup> Ampacity at ohmic load.
- <sup>d</sup> A varistor protects the Triac against excessive voltages, such as can occur during switching processes.
- <sup>e</sup> PhotoMOS® is a registered trademark of Panasonic.
- <sup>f</sup> Current limiting via the logic output of the device.

**Voltage supply outputs, Base unit**

Description	Output voltage	Ampacity	Connection
DC 12 V/24 V voltage supply <sup>a</sup> (e.g. for external transmitters)	DC 12 V +15 / -25 %	25 mA	Spring-cage terminals
	DC 24 V +15 / -25 %	30 mA	
DC ±5 V voltage supply (e.g. for ISFET pH-sensors)	DC +5 V ±15 %	200 mA	
	DC -5 V ±15 %	40 mA	

<sup>a</sup> Based on order code.

**Voltage supply outputs, power supply unit board**

Description	Output voltage	Total ampacity <sup>a</sup>	Connection
PWR OUT	AC 110 to 240 V +10 / -15 %; 48 to 63 Hz or AC/DC 20 ... 30 V; 48 ... 63 Hz	4 A	Spring-cage terminals

<sup>a</sup> The sum total of the output currents for the two PWR OUT connections must not exceed the total ampacity.

**Voltage supply outputs, optional board**

Description	Output voltage	Ampacity	Connection
DC 24 V voltage supply for external transmitters <sup>a</sup>	DC 24 V	30 mA	Screw terminals
DC ±5 V voltage supply (e.g. for ISFET pH-sensors)	DC +5 V ±15 % (between terminals 3 and 4)	150 mA	
	DC -5 V ±15 % (between terminals 5 and 4)	30 mA	

<sup>a</sup> An optional board for voltage supply outputs accommodates all the outputs listed in this table. A maximum of 1 such optional board can be integrated into a device.

**Interfaces**

**Serial interface RS422/485 (Base unit and optional board)**

Protocol	Data formats <sup>a</sup>	Device addresses	Baud rates in baud	Connection
Modbus (slave)	8 - 1 - no parity 8 - 1 - odd parity 8 - 1 - even parity	1 to 254	9600 19200 38400	Spring-cage terminals

<sup>a</sup> Specification in useful bit - stop bit - parity format. Therefore, the frame always comprises 8 useful bits and 1 stop bit. Only the parity is differentiated.



**JUMO GmbH & Co. KG**  
 Delivery address: Mackenrodtstraße 14  
 36039 Fulda, Germany  
 Postal address: 36035 Fulda, Germany  
 Phone: +49 661 6003-0  
 Fax: +49 661 6003-607  
 E-mail: mail@jumo.net  
 Internet: www.jumo.net

**JUMO Instrument Co. Ltd.**  
 JUMO House  
 Temple Bank, Riverway  
 Harlow, Essex CM20 2DY, UK  
 Phone: +44 1279 635533  
 Fax: +44 1279 635262  
 E-mail: sales@jumo.co.uk  
 Internet: www.jumo.co.uk

**JUMO Process Control, Inc.**  
 6733 Myers Road  
 East Syracuse, NY 13057, USA  
 Phone: 315-437-5866  
 1-800-554-5866  
 Fax: 315-437-5860  
 E-mail: info.us@jumo.net  
 Internet: www.jumousa.com

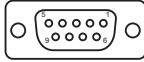

**PROFIBUS-DP (optional board)**

Protocol	Data formats <sup>a</sup>	Device addresses	Baud rates	Connection
DP-V0	Big Endian Little Endian	0 to 127	12 MBaud	D-sub socket 9-pole 

<sup>a</sup> Big Endian corresponds to the Motorola® data format and Little Endian to Intel® data format.

**Ethernet optional board (10/100Base-T)**

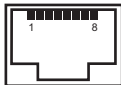
Function	Use	Application protocol/ program	Special features	Connection
Web server	Online visualization via web browser	HTTP	Editable via HTML Editor	RJ 45 socket 
Email / SMS text message <sup>a</sup>	Email dispatch via SMTP server Transmission as SMS text message	SMTP	Five email templates can be stored, up to 3 receivers for each email template	
Modbus TCP/IP	Process data exchange with Modbus users <sup>b</sup>	Modbus TCP/IP slave	TCP Port: 502	
Automatic IP configuration	Network administration <sup>c</sup>	DHCP	-	
Setup via PC	Device settings via PC setup program	JUMO PC setup program (HTTP)	-	
Recording function <sup>d</sup>	Extract, archive, evaluate measurement data	JUMO PCC and PCA3000	-	



<sup>a</sup> The email function allows the device, triggered by internal and/or external binary signals, to send hard-programmed messages. This requires the data of an SMTP server (email intermediate server) to be known. The email function can be configured exclusively via the PC setup program.

<sup>b</sup> Modbus TCP/IP enables Modbus users to communicate via a LAN, provided this is connected to the LAN (e.g. via gateways). To configure a Modbus communication, you will require the interface description for the JUMO AQUIS touch S.

<sup>c</sup> Enlist the help of your network administrator or an IT specialist for the IP configuration.

<sup>d</sup> The recording function stores measurement data in a ring buffer inside the device. Further details appear on Page 15.

**USB interfaces, Base unit**

Interface	Use	Support	Connection	Version
USB host interface	Extract measurement data memory <sup>a</sup> Read/write device settings Save service data <sup>b</sup> Updating the firmware	USB flash drive	USB port type A 	USB 2.0
USB device interface	Device setting via PC setup program Extract, archive, evaluate measurement data	JUMO PC setup program JUMO PCC/PCA3000 software	USB port type Mini-B 	

<sup>a</sup> The recording function stores measurement data in a ring buffer inside the device. Further details appear on Page 15.

<sup>b</sup> Service data can be stored on a USB flash drive for diagnostic purposes.

**JUMO GmbH & Co. KG**

Delivery address: Mackenrodtstraße 14  
36039 Fulda, Germany  
Postal address: 36035 Fulda, Germany  
Phone: +49 661 6003-0  
Fax: +49 661 6003-607  
E-mail: mail@jumo.net  
Internet: www.jumo.net

**JUMO Instrument Co. Ltd.**

JUMO House  
Temple Bank, Riverway  
Harlow, Essex CM20 2DY, UK  
Phone: +44 1279 635533  
Fax: +44 1279 635262  
E-mail: sales@jumo.co.uk  
Internet: www.jumo.co.uk

**JUMO Process Control, Inc.**

6733 Myers Road  
East Syracuse, NY 13057, USA  
Phone: 315-437-5866  
1-800-554-5866  
Fax: 315-437-5860  
E-mail: info.us@jumo.net  
Internet: www.jumousa.com

**Electrical data**

Voltage supply (switch mode PSU)	AC 110 ... 240 V +10 / -15 %; 48 ... 63 Hz or AC/DC 20 ... 30 V; 48 ... 63 Hz
Electrical safety	According to EN 61010, part 1 overvoltage category III, pollution degree 2
Max. power consumption AC 110 ... 240 V AC/DC 20 ... 30 V	53.7 VA 26.2 VA
Data backup	Flash memory
Electrical connection	Spring-cage terminals and screw terminals Specifications for conductor cross sections on Page 16
Electromagnetic compatibility (EMC): Interference emission Interference immunity	DIN EN 61326-1 Class B Industrial requirements

**Touchscreen**

Type	TFT-touchscreen
Touchscreen sensors	Resistive (can also be operated wearing gloves)
Display protection	Plastic film for protection against damage and scratches
Size	5.5"
Resolution	320 × 240 pixel
Color depth	256 colors
Viewing angle	Horizontal: ±70° Vertical: -70 to +50°

**Case**

Case type	Surface-mounted case made of plastic (ABS)
Materials	Terminal compartment cover screws: 1.4567 stainless steel Mounting plate: 1.4301 stainless steel
Dimensions	301.5 mm × 283.2 mm × 120.5 mm
Ambient temperature Storage temperature	-5 ... +50 °C -30 ... +70 °C
Resistance to climatic conditions	Relative humidity < 92 % annual average, no condensation
Operating position	Any (with due consideration for the viewing angle of the screen)
Protection class Closed case Open case	According to EN 60529 IP67 IP20
Cable entries Scope of delivery Standard version  Full configuration kit (see accessories)	Cable fittings: 6× M12 × 1.5 3× M16 × 1.5  Cable fittings: 9× M12 × 1.5 2× M16 × 1.5 2× M20 × 1.5
Weight without holder for wall mounting (fully configured)	3390 g
Weight of holder for wall mounting	790 g

**JUMO GmbH & Co. KG**  
 Delivery address: Mackenrodtstraße 14  
 36039 Fulda, Germany  
 Postal address: 36035 Fulda, Germany  
 Phone: +49 661 6003-0  
 Fax: +49 661 6003-607  
 E-mail: mail@jumo.net  
 Internet: www.jumo.net

**JUMO Instrument Co. Ltd.**  
 JUMO House  
 Temple Bank, Riverway  
 Harlow, Essex CM20 2DY, UK  
 Phone: +44 1279 635533  
 Fax: +44 1279 635262  
 E-mail: sales@jumo.co.uk  
 Internet: www.jumo.co.uk

**JUMO Process Control, Inc.**  
 6733 Myers Road  
 East Syracuse, NY 13057, USA  
 Phone: 315-437-5866  
 1-800-554-5866  
 Fax: 315-437-5860  
 E-mail: info.us@jumo.net  
 Internet: www.jumousa.com



**Functions**

**Controller channels**

Quantity	4
Controller type	Two-state controller Three-state controller Continuous controller Coarse/fine controller Three-step controller Continuous controller with position controller
Controller structure	P, PI, PD, PID
Controller outputs	For each controller channel, 2 outputs configurable as: pulse length output, pulse frequency output, continuous output
Disturbance feed-forward control	Multiplicative and/or additive <sup>a</sup>
Autotuning	Step response method

<sup>a</sup> Disturbance feed-forward control allows influencing variables in the process environment going beyond the actual value to be considered. This keeps the controller behavior stable, even when fluctuations in such ambient conditions occur.

**Recording function**

	Data monitor	Recording function (optional)
Number of groups <sup>a</sup>	2	2
Number of input variables per group	4x analog 3x binary	4x analog 3x binary
Recording / memory cycles	1 to 3600 sec.	1 to 3600 sec.
Memory values	Current value Average value Minimum value Maximum value	Current value Average value Minimum value Maximum value
Size of the ring buffer <sup>b</sup>	Sufficient for 150 entries <sup>c</sup>	Sufficient for approx. 31 million entries <sup>c</sup>
History function <sup>d</sup>	No	Yes
Archiving/evaluation	No	Yes (via JUMO PCA3000 evaluation software)

<sup>a</sup> A freely configurable set of input variables can be pooled in one group. Each group has its own display screen. The group affiliation is considered for data storage, in order to enable evaluation via PC.

<sup>b</sup> The measurement data are stored in a ring buffer. When the ring buffer is full, the recording function begins at the start of the ring buffer by overwriting the measured value history.

<sup>c</sup> The specification relates to 4 analog values and 3 binary values per entry and aids orientation. The sum total of both groups is indicated.

<sup>d</sup> The history function allows you to scroll through the diagram to past recording times. All measurement data stored in the ring buffer can therefore be viewed on the device.

**Customer-specific linearization**

<sup>a</sup> Number of support points	Up to 40 value pairs
Interpolation <sup>b</sup>	Linear
Formula entry <sup>c</sup>	4th degree polynomial

<sup>a</sup> The approximate characteristic line can be entered by inputting support points (value pairs of the customer-specific characteristic line).

<sup>b</sup> Linear interpolation means the formation of a slope function through 2 support points.

<sup>c</sup> As an alternative to support point entry, a customer-specific characteristic line can also be entered as a formula in the form of a polynomial.

**Approvals / approval marks**

Approval mark	Testing agency	Certificates / certification numbers	Inspection basis	Valid for
	Underwriters Laboratories	Registered	UL 61010-1 CAN/CSA-C22.2 No. 61010-1	Type 202581/...

**JUMO GmbH & Co. KG**  
 Delivery address: Mackenrodtstraße 14  
 36039 Fulda, Germany  
 Postal address: 36035 Fulda, Germany  
 Phone: +49 661 6003-0  
 Fax: +49 661 6003-607  
 E-mail: mail@jumo.net  
 Internet: www.jumo.net

**JUMO Instrument Co. Ltd.**  
 JUMO House  
 Temple Bank, Riverway  
 Harlow, Essex CM20 2DY, UK  
 Phone: +44 1279 635533  
 Fax: +44 1279 635262  
 E-mail: sales@jumo.co.uk  
 Internet: www.jumo.co.uk

**JUMO Process Control, Inc.**  
 6733 Myers Road  
 East Syracuse, NY 13057, USA  
 Phone: 315-437-5866  
 1-800-554-5866  
 Fax: 315-437-5860  
 E-mail: info.us@jumo.net  
 Internet: www.jumousa.com



## Connection diagram

The connection diagram in the data sheet provides preliminary information about the connection options. For the electrical connection, only the installation instructions or the operating manual should be used. The knowledge and the correct technical execution of the safety information/ instructions contained in these documents are mandatory for installation, electrical connection, startup, and for safety during operation.

### Important information on conductor cross-sections and ferrules

Ferrule	Conductor cross-section		Minimum length of ferrule or stripping
	Minimum	Maximum	
Without ferrule			
Power supply unit	0.2 mm <sup>2</sup>	1 mm <sup>2</sup>	8 mm
Base unit	0.2 mm <sup>2</sup>	1 mm <sup>2</sup>	8 mm
With ferrule without lip			
Power supply unit	0.25 mm <sup>2</sup>	0.75 mm <sup>2</sup>	8 mm
Base unit	0.25 mm <sup>2</sup>	0.75 mm <sup>2</sup>	8 mm
With ferrule with lip			
Power supply unit	0.25 mm <sup>2</sup>	0.75 mm <sup>2</sup>	8 mm
Base unit	0.25 mm <sup>2</sup>	0.75 mm <sup>2</sup>	8 mm
Rigid			
Power supply unit	0.2 mm <sup>2</sup>	1.5 mm <sup>2</sup>	8 mm
Base unit	0.2 mm <sup>2</sup>	1.5 mm <sup>2</sup>	8 mm

### Connection overview

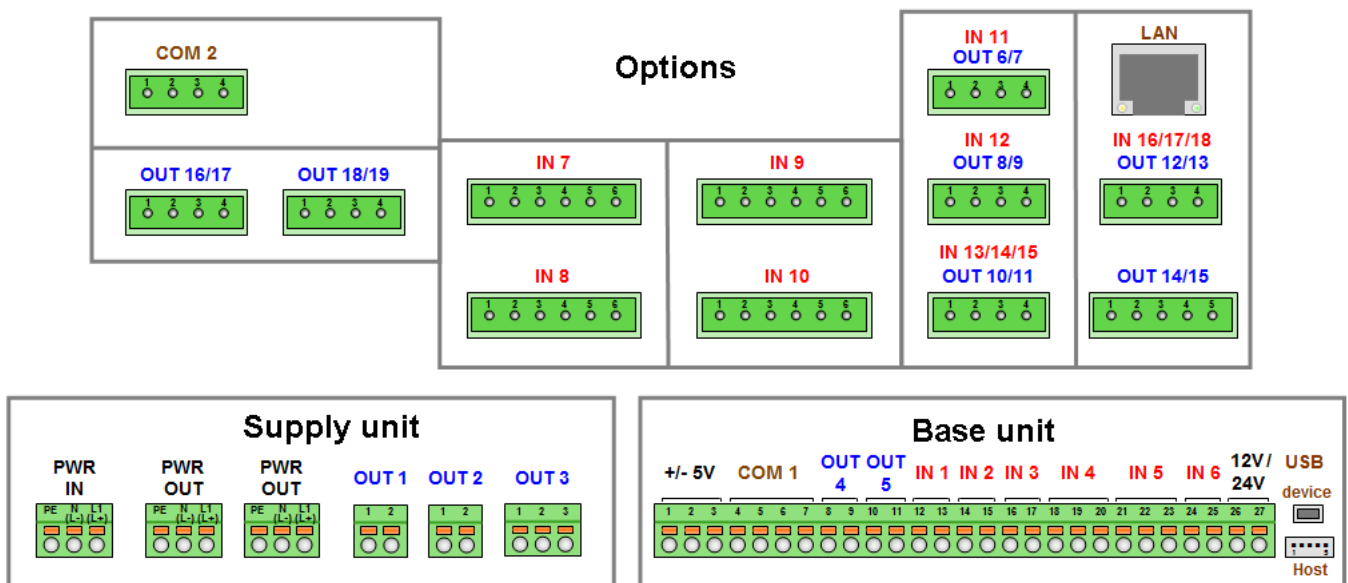



**JUMO GmbH & Co. KG**  
 Delivery address: Mackenrodtstraße 14  
 36039 Fulda, Germany  
 Postal address: 36035 Fulda, Germany  
 Phone: +49 661 6003-0  
 Fax: +49 661 6003-607  
 E-mail: mail@jumo.net  
 Internet: www.jumo.net

**JUMO Instrument Co. Ltd.**  
 JUMO House  
 Temple Bank, Riverway  
 Harlow, Essex CM20 2DY, UK  
 Phone: +44 1279 635533  
 Fax: +44 1279 635262  
 E-mail: sales@jumo.co.uk  
 Internet: www.jumo.co.uk

**JUMO Process Control, Inc.**  
 6733 Myers Road  
 East Syracuse, NY 13057, USA  
 Phone: 315-437-5866  
 1-800-554-5866  
 Fax: 315-437-5860  
 E-mail: info.us@jumo.net  
 Internet: www.jumousa.com



**Analog inputs, Base unit**

Connector/terminal	Connection variant	Symbol
IN 4	RTD temperature probe 2-wire circuit Pt100, Pt1000, or customer-specific characteristic line	18 20
	RTD temperature probe 3-wire circuit Pt100, Pt1000, or customer-specific characteristic	18 19 20
IN 5	RTD temperature probe 2-wire circuit Pt100, Pt1000, or customer-specific characteristic line	21 23
	RTD temperature probe 3-wire circuit Pt100, Pt1000, or customer-specific characteristic	21 22 23
	NTC 2-wire circuit	21 23
	NTC 3-wire circuit	21 22 23
	Resistance transmitter A = Start E = End S = Slider	21 22 23
IN 6	Standard signal for current 0(4) to 20 mA	+ 24 - I <sub>x</sub> 25

**JUMO GmbH & Co. KG**  
 Delivery address: Mackenrodtstraße 14  
 36039 Fulda, Germany  
 Postal address: 36035 Fulda, Germany  
 Phone: +49 661 6003-0  
 Fax: +49 661 6003-607  
 E-mail: mail@jumo.net  
 Internet: www.jumo.net

**JUMO Instrument Co. Ltd.**  
 JUMO House  
 Temple Bank, Riverway  
 Harlow, Essex CM20 2DY, UK  
 Phone: +44 1279 635533  
 Fax: +44 1279 635262  
 E-mail: sales@jumo.co.uk  
 Internet: www.jumo.co.uk

**JUMO Process Control, Inc.**  
 6733 Myers Road  
 East Syracuse, NY 13057, USA  
 Phone: 315-437-5866  
 1-800-554-5866  
 Fax: 315-437-5860  
 E-mail: info.us@jumo.net  
 Internet: www.jumousa.com



## Analog inputs, optional boards

### Universal inputs

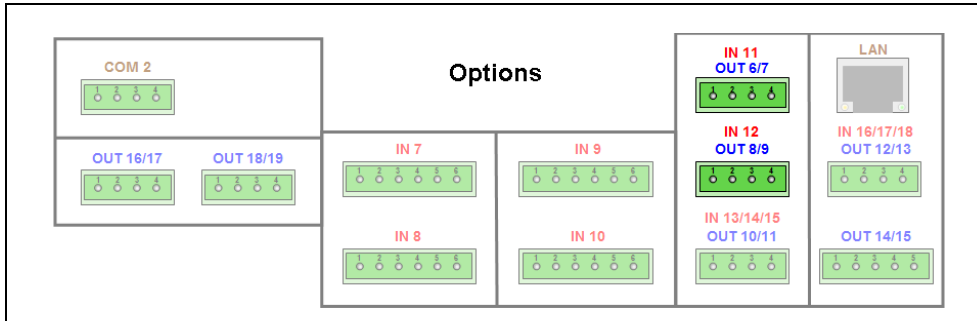

Expansion slot	Connection variant	Symbol
IN 11 IN 12	RTD temperature probe 2-wire circuit Pt100, Pt1000, or customer-specific characteristic line	
	RTD temperature probe 3-wire circuit Pt100, Pt1000, or customer-specific characteristic line	
	Resistance transmitter A = Start E = End S = Slider	
	Standard signal Voltage 0 to 10 V	
	Standard signal Current 0(4) to 20 mA	

**JUMO GmbH & Co. KG**  
 Delivery address: Mackenrodtstraße 14  
 36039 Fulda, Germany  
 Postal address: 36035 Fulda, Germany  
 Phone: +49 661 6003-0  
 Fax: +49 661 6003-607  
 E-mail: mail@jumo.net  
 Internet: www.jumo.net

**JUMO Instrument Co. Ltd.**  
 JUMO House  
 Temple Bank, Riverway  
 Harlow, Essex CM20 2DY, UK  
 Phone: +44 1279 635533  
 Fax: +44 1279 635262  
 E-mail: sales@jumo.co.uk  
 Internet: www.jumo.co.uk

**JUMO Process Control, Inc.**  
 6733 Myers Road  
 East Syracuse, NY 13057, USA  
 Phone: 315-437-5866  
 1-800-554-5866  
 Fax: 315-437-5860  
 E-mail: info.us@jumo.net  
 Internet: www.jumousa.com



**Analysis inputs**

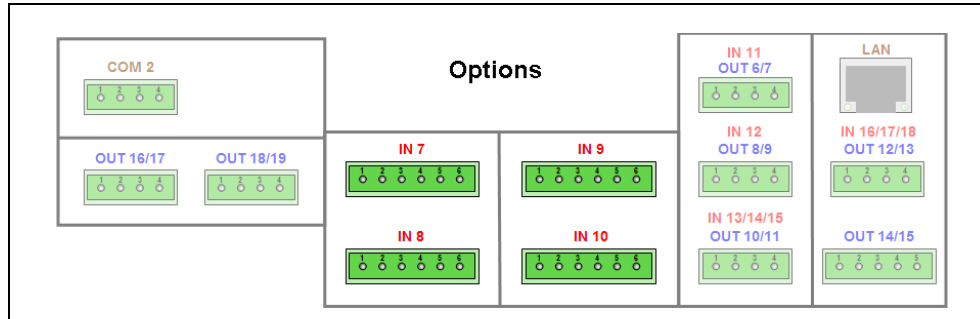

Expansion slot	Option / connection variant	Symbol
IN 7 IN 8 IN 9 IN 10	pH/Redox Symmetric connection a = glass/metal electrode b = reference electrode FP= liquid potential GND = shielding Terminals 2 and 4 are not connected!	
	pH/Redox Asymmetric connection a = glass/metal electrode b = reference electrode GND = shielding Terminals 2 and 4 are not connected!	
	Conductivity, inductive (Ci) connection via M12 connector, connect compensation thermometer connections (2-core cable of connection socket) to a suitable analog input (2-wire circuit) <b>factory wiring must not be changed!</b>	
	Conductivity, conductive (CR) 2-electrode system with 2-wire conductor with concentric conductivity sensors, terminal 1 must be connected to the outer electrode.	
	Conductivity, conductive (CR) 2-electrode system with 4-wire conductor; wiring to minimize the measuring error caused by lead- wire resistance; With concentric conductivity sensors, terminal 1 must be connected to the outer electrode.	
	Conductivity, conductive (CR) 4-electrode system; 1: Outer electrode 1 (I hi) 2: Inner electrode 1 (U hi) 2: Inner electrode 2 (U lo) 4: Outer electrode 2 (I lo) 6: Shielding	





**JUMO GmbH & Co. KG**  
 Delivery address: Mackenrodtstraße 14  
 36039 Fulda, Germany  
 Postal address: 36035 Fulda, Germany  
 Phone: +49 661 6003-0  
 Fax: +49 661 6003-607  
 E-mail: mail@jumo.net  
 Internet: www.jumo.net

**JUMO Instrument Co. Ltd.**  
 JUMO House  
 Temple Bank, Riverway  
 Harlow, Essex CM20 2DY, UK  
 Phone: +44 1279 635533  
 Fax: +44 1279 635262  
 E-mail: sales@jumo.co.uk  
 Internet: www.jumo.co.uk

**JUMO Process Control, Inc.**  
 6733 Myers Road  
 East Syracuse, NY 13057, USA  
 Phone: 315-437-5866  
 1-800-554-5866  
 Fax: 315-437-5860  
 E-mail: info.us@jumo.net  
 Internet: www.jumousa.com



**Binary inputs**

**Base unit**

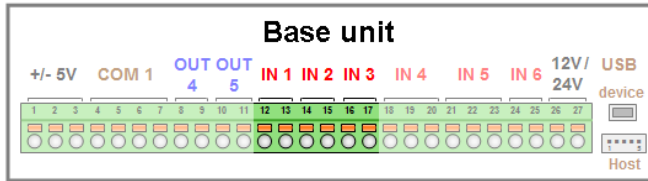

Connector/terminal	Connection variant	Symbol
IN 1	Binary input (potential-free contact)	
	Binary input (external voltage source)	
IN 2	Binary input (potential-free contact)	
	Binary input (external voltage source)	
IN 3	Binary input (potential-free contact)	
	Binary input (external voltage source)	

**Optional boards:**

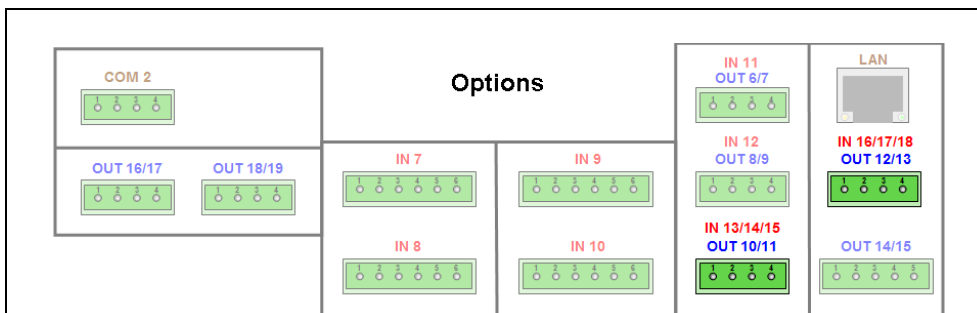

Connector/terminal	Connection variant	Symbol
IN 13/14/15 IN 16/17/18	3x binary input	

**JUMO GmbH & Co. KG**  
 Delivery address: Mackenrodtstraße 14  
 36039 Fulda, Germany  
 Postal address: 36035 Fulda, Germany  
 Phone: +49 661 6003-0  
 Fax: +49 661 6003-607  
 E-mail: mail@jumo.net  
 Internet: www.jumo.net

**JUMO Instrument Co. Ltd.**  
 JUMO House  
 Temple Bank, Riverway  
 Harlow, Essex CM20 2DY, UK  
 Phone: +44 1279 635533  
 Fax: +44 1279 635262  
 E-mail: sales@jumo.co.uk  
 Internet: www.jumo.co.uk

**JUMO Process Control, Inc.**  
 6733 Myers Road  
 East Syracuse, NY 13057, USA  
 Phone: 315-437-5866  
 1-800-554-5866  
 Fax: 315-437-5860  
 E-mail: info.us@jumo.net  
 Internet: www.jumousa.com



**Binary outputs**

**Power supply unit board**

Supply unit		
Connector/terminal	Connection variant	Symbol
OUT 1 OUT 2	Relay Normally open contacts	
OUT 3	Relay Changeover contact	

**Optional boards:**

Options		
Expansion slot	Option / connection variant	Symbol
OUT 6/7 OUT 8/9 OUT 10/11 OUT 12/13 OUT 14/15 OUT 16/17 OUT 18/19	Relay Changeover contact	
	2x relays N/O contact <sup>a</sup>	
	Solid state relay Triac 230 V/1 A	
	2x solid state relays PhotoMOS <sup>®b</sup> 50 V/200 mA	
	Binary output 0/22 V	

**JUMO GmbH & Co. KG**  
 Delivery address: Mackenrodtstraße 14  
 36039 Fulda, Germany  
 Postal address: 36035 Fulda, Germany  
 Phone: +49 661 6003-0  
 Fax: +49 661 6003-607  
 E-mail: mail@jumo.net  
 Internet: www.jumo.net

**JUMO Instrument Co. Ltd.**  
 JUMO House  
 Temple Bank, Riverway  
 Harlow, Essex CM20 2DY, UK  
 Phone: +44 1279 635533  
 Fax: +44 1279 635262  
 E-mail: sales@jumo.co.uk  
 Internet: www.jumo.co.uk

**JUMO Process Control, Inc.**  
 6733 Myers Road  
 East Syracuse, NY 13057, USA  
 Phone: 315-437-5866  
 1-800-554-5866  
 Fax: 315-437-5860  
 E-mail: info.us@jumo.net  
 Internet: www.jumousa.com

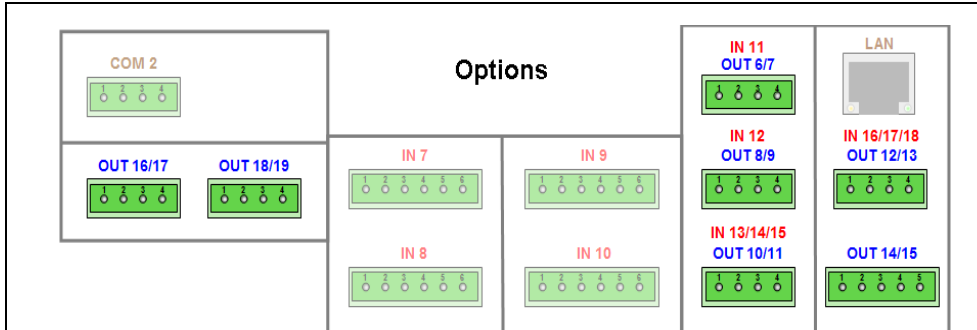

Expansion slot	Option / connection variant	Symbol
OUT 6/7 OUT 8/9 OUT 10/11 OUT 12/13 OUT 14/15 OUT 16/17 OUT 18/19	2x binary outputs 0/12 V	1 2 3 4

<sup>a</sup> Combining a mains voltage circuit with a protective low voltage circuit on a 2-way normally open contact option is not admissible.

<sup>b</sup> PhotoMOS® is a registered trademark of Panasonic.

**Mains power connection**

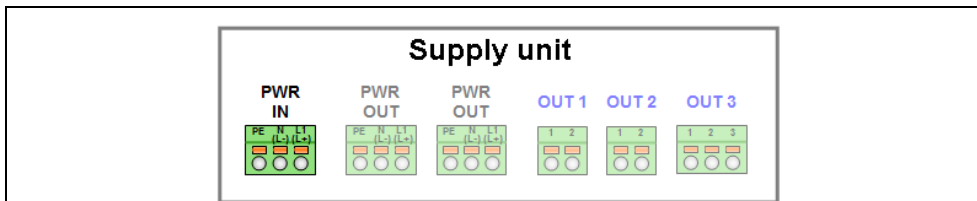

Connector/terminal	Connection variant	Symbol
PWR IN	Mains power input	L1 N PE

**Voltage supply outputs**

Base unit

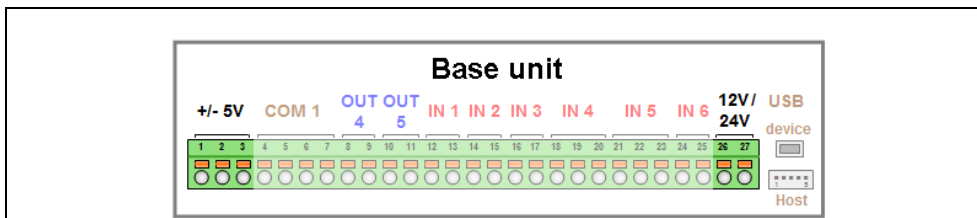

Connector/terminal	Connection variant	Symbol
DC ±5 V	Voltage supply for ISFET sensors	1 2 3
DC 12 V/24 V	Voltage supply for external transmitters 12 V / 24 V	26 27 27

**JUMO GmbH & Co. KG**  
 Delivery address: Mackenrodtstraße 14  
 36039 Fulda, Germany  
 Postal address: 36035 Fulda, Germany  
 Phone: +49 661 6003-0  
 Fax: +49 661 6003-607  
 E-mail: mail@jumo.net  
 Internet: www.jumo.net

**JUMO Instrument Co. Ltd.**  
 JUMO House  
 Temple Bank, Riverway  
 Harlow, Essex CM20 2DY, UK  
 Phone: +44 1279 635533  
 Fax: +44 1279 635262  
 E-mail: sales@jumo.co.uk  
 Internet: www.jumo.co.uk

**JUMO Process Control, Inc.**  
 6733 Myers Road  
 East Syracuse, NY 13057, USA  
 Phone: 315-437-5866  
 1-800-554-5866  
 Fax: 315-437-5860  
 E-mail: info.us@jumo.net  
 Internet: www.jumousa.com



**Power supply unit board**

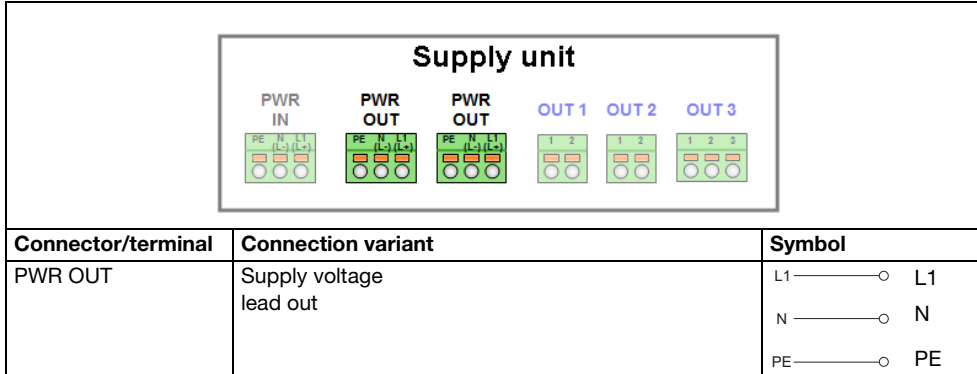

**Optional board**

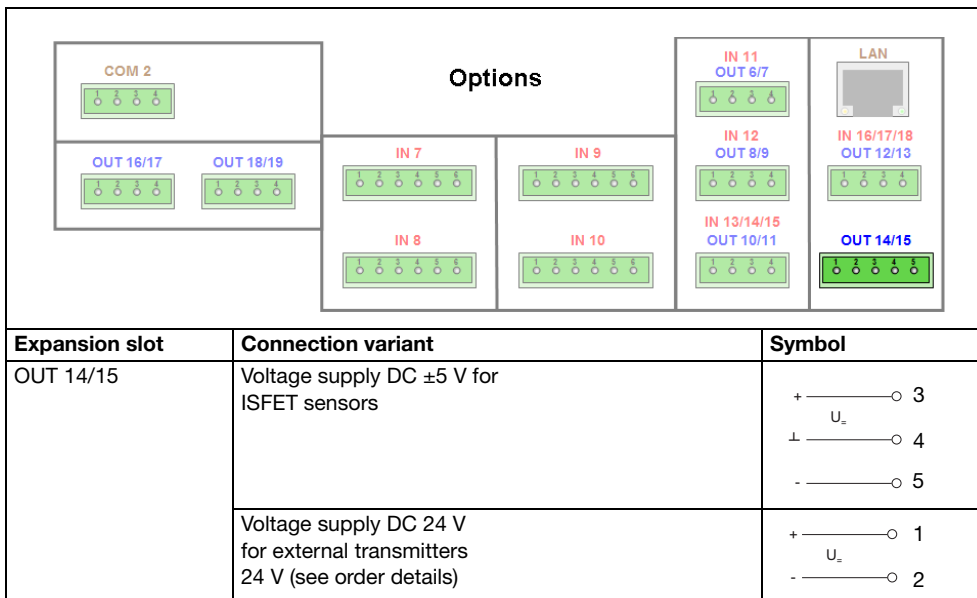



**JUMO GmbH & Co. KG**  
 Delivery address: Mackenrodtstraße 14  
 36039 Fulda, Germany  
 Postal address: 36035 Fulda, Germany  
 Phone: +49 661 6003-0  
 Fax: +49 661 6003-607  
 E-mail: mail@jumo.net  
 Internet: www.jumo.net

**JUMO Instrument Co. Ltd.**  
 JUMO House  
 Temple Bank, Riverway  
 Harlow, Essex CM20 2DY, UK  
 Phone: +44 1279 635533  
 Fax: +44 1279 635262  
 E-mail: sales@jumo.co.uk  
 Internet: www.jumo.co.uk

**JUMO Process Control, Inc.**  
 6733 Myers Road  
 East Syracuse, NY 13057, USA  
 Phone: 315-437-5866  
 1-800-554-5866  
 Fax: 315-437-5860  
 E-mail: info.us@jumo.net  
 Internet: www.jumousa.com



**Interfaces**

**Base unit**

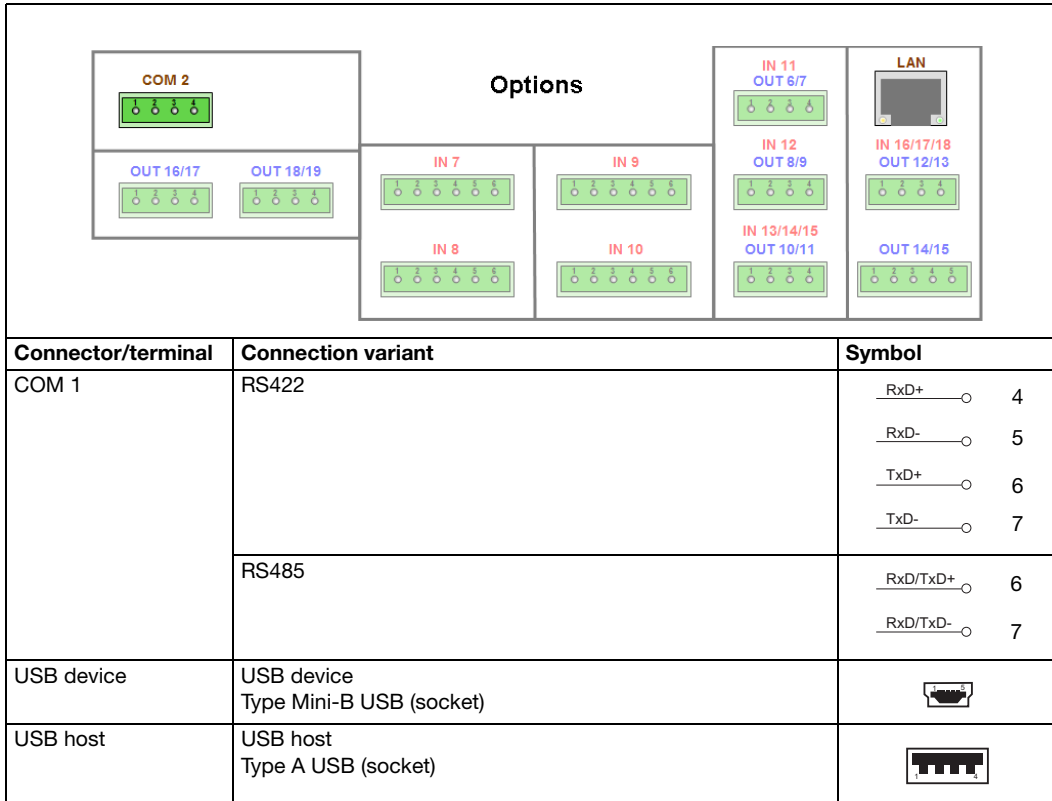

**JUMO GmbH & Co. KG**  
 Delivery address: Mackenrodtstraße 14  
 36039 Fulda, Germany  
 Postal address: 36035 Fulda, Germany  
 Phone: +49 661 6003-0  
 Fax: +49 661 6003-607  
 E-mail: mail@jumo.net  
 Internet: www.jumo.net

**JUMO Instrument Co. Ltd.**  
 JUMO House  
 Temple Bank, Riverway  
 Harlow, Essex CM20 2DY, UK  
 Phone: +44 1279 635533  
 Fax: +44 1279 635262  
 E-mail: sales@jumo.co.uk  
 Internet: www.jumo.co.uk

**JUMO Process Control, Inc.**  
 6733 Myers Road  
 East Syracuse, NY 13057, USA  
 Phone: 315-437-5866  
 1-800-554-5866  
 Fax: 315-437-5860  
 E-mail: info.us@jumo.net  
 Internet: www.jumousa.com



**Optional boards:**

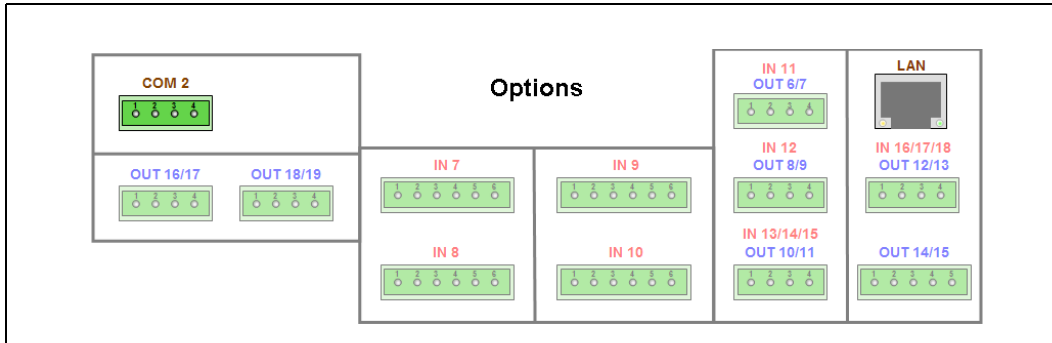

Expansion slot	Connection variant	Terminating resistors	Symbol
COM 2	RS422 The terminating resistors with DIP switches on optional boards Configurable	With terminating resistors 	RxD+ —○ 1 RxD- —○ 2 TxD+ —○ 3 TxD- —○ 4
	RS485 The terminating resistors with DIP switches on optional boards Configurable	Without terminating resistors 	RxD/TxD+ —○ 3 RxD/TxD- —○ 4
	PROFIBUS-DP 3 = RxD/TxD-P 5 = DGND 6 = VP 8 = RxD/TxD-N	-	
LAN	Ethernet Type RJ 45 (socket)	-	



## Galvanic isolation

### Option plug-in boards

### Base unit and power supply unit board

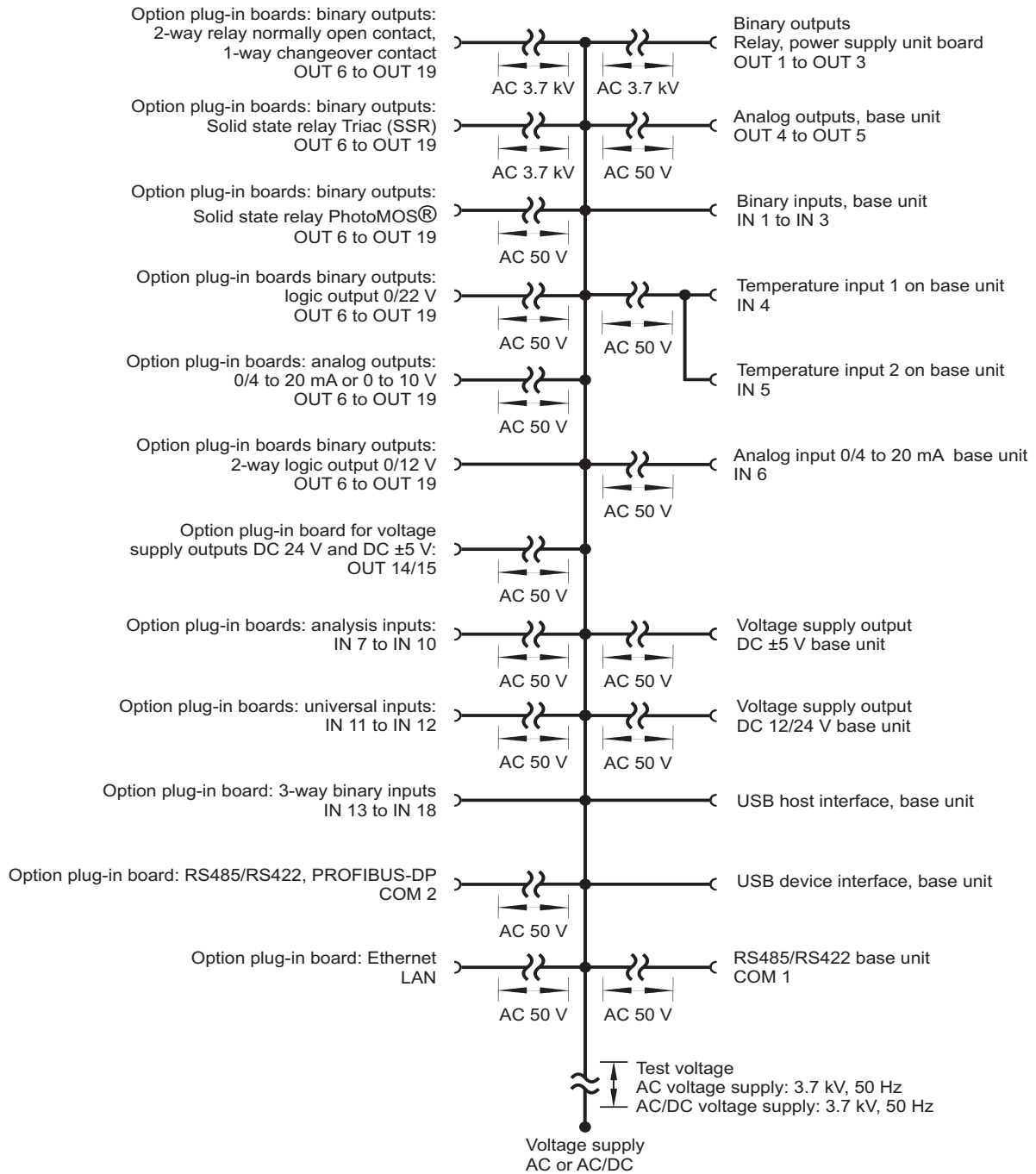

### Warning:

If sensors without galvanic isolation are operated at a binary input and can be powered by an external voltage source, potential differences between the internal and the external ground can cause problems. Drawing the voltage from the voltage supply outputs on the JUMO AQUIS touch S is therefore preferred.

**JUMO GmbH & Co. KG**  
Delivery address: Mackenrodtstraße 14  
36039 Fulda, Germany  
Postal address: 36035 Fulda, Germany  
Phone: +49 661 6003-0  
Fax: +49 661 6003-607  
E-mail: mail@jumo.net  
Internet: www.jumo.net

**JUMO Instrument Co. Ltd.**  
JUMO House  
Temple Bank, Riverway  
Harlow, Essex CM20 2DY, UK  
Phone: +44 1279 635533  
Fax: +44 1279 635262  
E-mail: sales@jumo.co.uk  
Internet: www.jumo.co.uk

**JUMO Process Control, Inc.**  
6733 Myers Road  
East Syracuse, NY 13057, USA  
Phone: 315-437-5866  
1-800-554-5866  
Fax: 315-437-5860  
E-mail: info.us@jumo.net  
Internet: www.jumousa.com



## Dimensions

View from below  
(Cable entries)

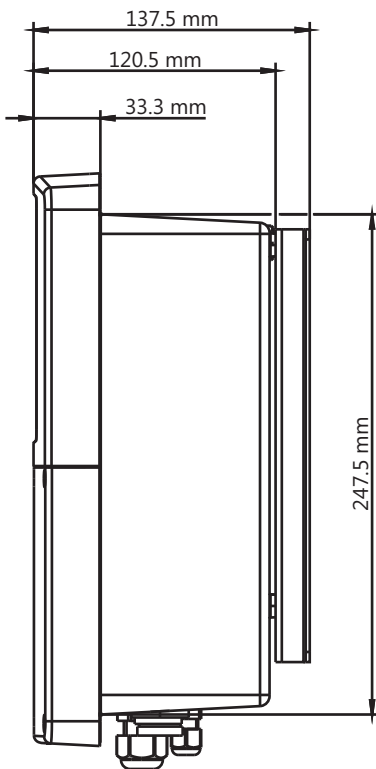
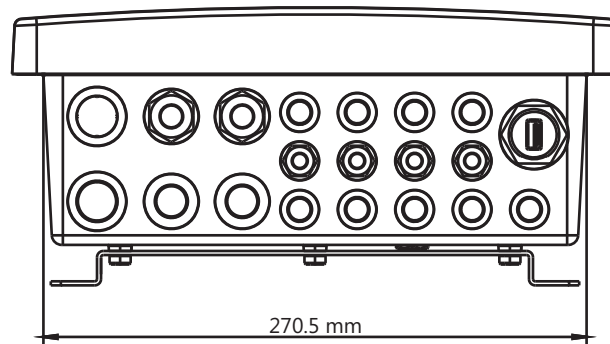

Side view

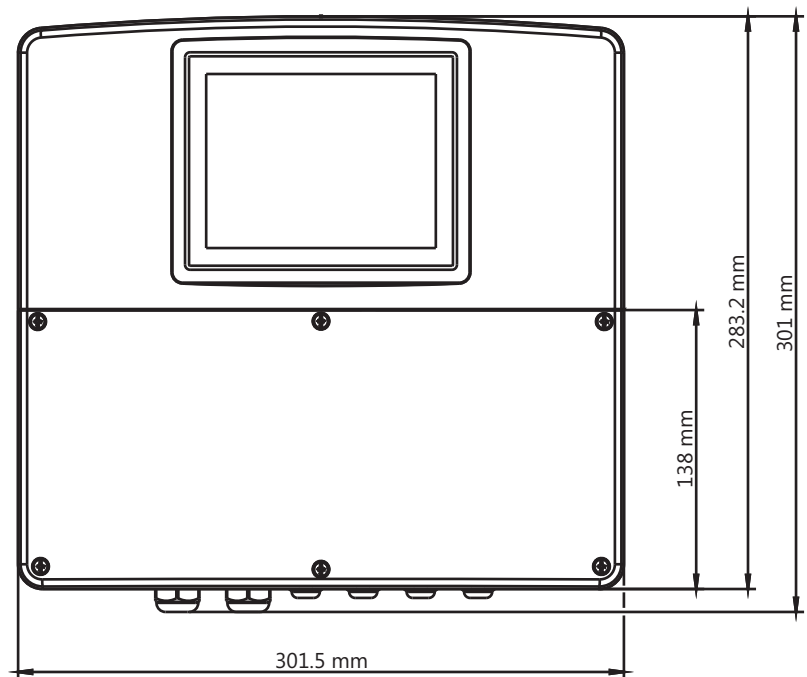

Front view

**JUMO GmbH & Co. KG**  
 Delivery address: Mackenrodtstraße 14  
 36039 Fulda, Germany  
 Postal address: 36035 Fulda, Germany  
 Phone: +49 661 6003-0  
 Fax: +49 661 6003-607  
 E-mail: mail@jumo.net  
 Internet: www.jumo.net

**JUMO Instrument Co. Ltd.**  
 JUMO House  
 Temple Bank, Riverway  
 Harlow, Essex CM20 2DY, UK  
 Phone: +44 1279 635533  
 Fax: +44 1279 635262  
 E-mail: sales@jumo.co.uk  
 Internet: www.jumo.co.uk

**JUMO Process Control, Inc.**  
 6733 Myers Road  
 East Syracuse, NY 13057, USA  
 Phone: 315-437-5866  
 1-800-554-5866  
 Fax: 315-437-5860  
 E-mail: info.us@jumo.net  
 Internet: www.jumousa.com



## Surface mounting

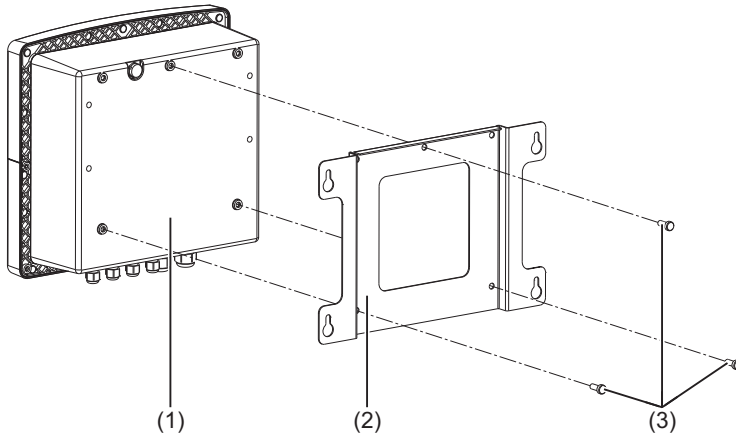

## Drilling diagram

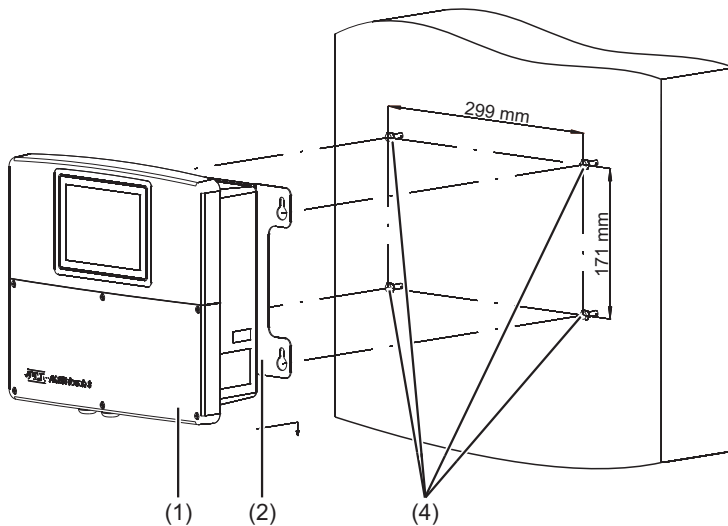
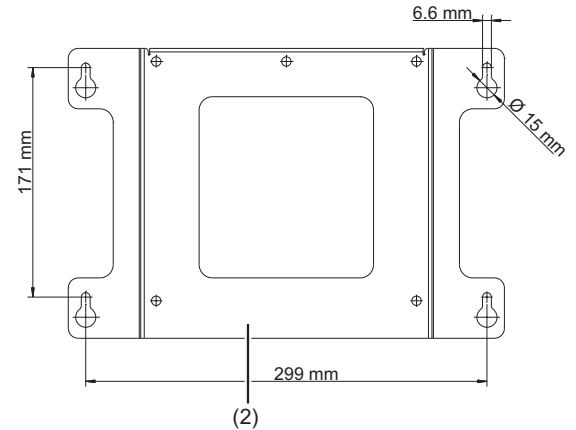

- (1) JUMO AQUIS touch S
- (2) Mounting plate
- (3) Self-tapping screws 60 × 16; TORX PLUS® 30IP (from the JUMO AQUIS touch S accessories pouch)
- (4) Fastening screws (hexagon screws Ø 6 mm)
- (5) Weather protection canopy (part no. 00602504)

<sup>a</sup> TORX PLUS® is a registered trademark of Acument Intellectual Properties, LLC, USA.

## Surface mounting with weather protection canopy

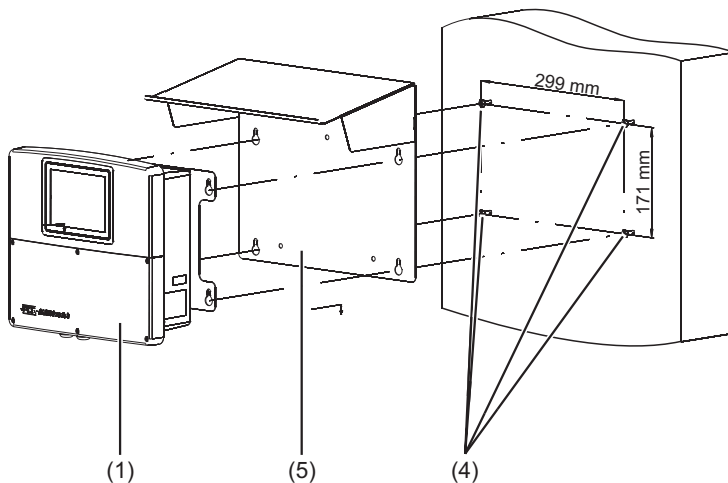



**JUMO GmbH & Co. KG**  
 Delivery address: Mackenrodtstraße 14  
 36039 Fulda, Germany  
 Postal address: 36035 Fulda, Germany  
 Phone: +49 661 6003-0  
 Fax: +49 661 6003-607  
 E-mail: mail@jumo.net  
 Internet: www.jumo.net

**JUMO Instrument Co. Ltd.**  
 JUMO House  
 Temple Bank, Riverway  
 Harlow, Essex CM20 2DY, UK  
 Phone: +44 1279 635533  
 Fax: +44 1279 635262  
 E-mail: sales@jumo.co.uk  
 Internet: www.jumo.co.uk

**JUMO Process Control, Inc.**  
 6733 Myers Road  
 East Syracuse, NY 13057, USA  
 Phone: 315-437-5866  
 1-800-554-5866  
 Fax: 315-437-5860  
 E-mail: info.us@jumo.net  
 Internet: www.jumousa.com



## Pipe mounting

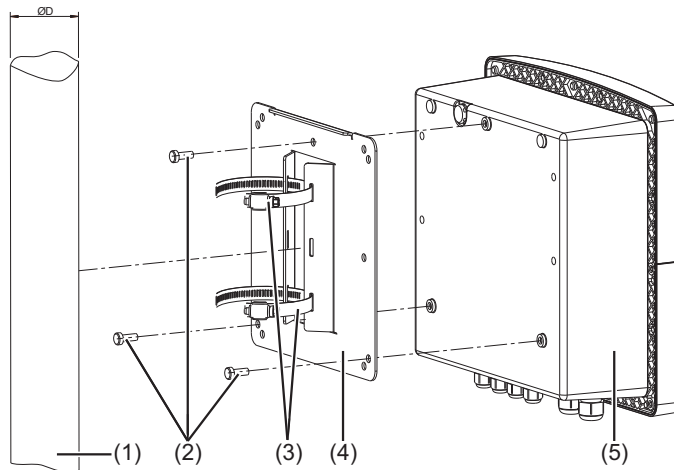

- (1) Pipe/pole (customer provision)  
clamping range of clips = D
- (2) Self-tapping screws 60 × 16;  
TORX PLUS®<sup>a</sup> 30IP (from the  
AQUIS touch S accessories  
pouch)
- (3) Pipe clips from the pipe  
mounting kit (part no.  
00602401)
- (4) Mounting plate for pipe mount-  
ing from the pipe mounting kit  
(part no. 00602401)
- (5) JUMO AQUIS touch S
- (6) Weather protection canopy  
(part no. 00602504)

<sup>a</sup> TORX PLUS® is a registered trademark  
of Acument Intellectual Pro-perties, LLC.  
USA.

## Pipe mounting with weather protection canopy

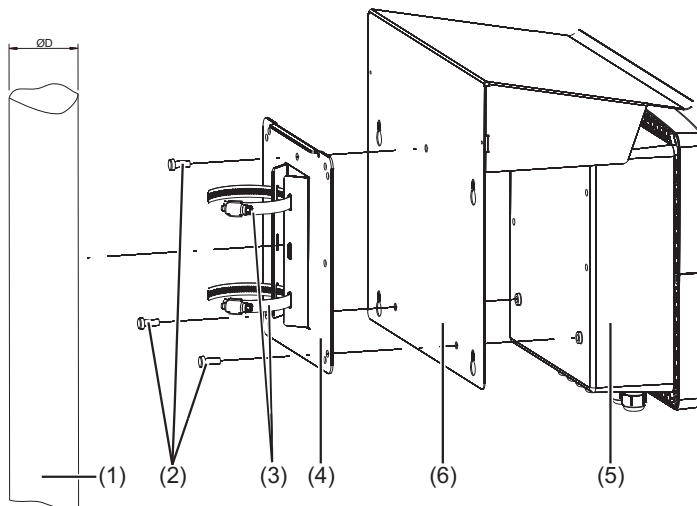

**JUMO GmbH & Co. KG**  
Delivery address: Mackenrodtstraße 14  
36039 Fulda, Germany  
Postal address: 36035 Fulda, Germany  
Phone: +49 661 6003-0  
Fax: +49 661 6003-607  
E-mail: mail@jumo.net  
Internet: www.jumo.net

**JUMO Instrument Co. Ltd.**  
JUMO House  
Temple Bank, Riverway  
Harlow, Essex CM20 2DY, UK  
Phone: +44 1279 635533  
Fax: +44 1279 635262  
E-mail: sales@jumo.co.uk  
Internet: www.jumo.co.uk

**JUMO Process Control, Inc.**  
6733 Myers Road  
East Syracuse, NY 13057, USA  
Phone: 315-437-5866  
1-800-554-5866  
Fax: 315-437-5860  
E-mail: info.us@jumo.net  
Internet: www.jumousa.com



## Installation into the control panel

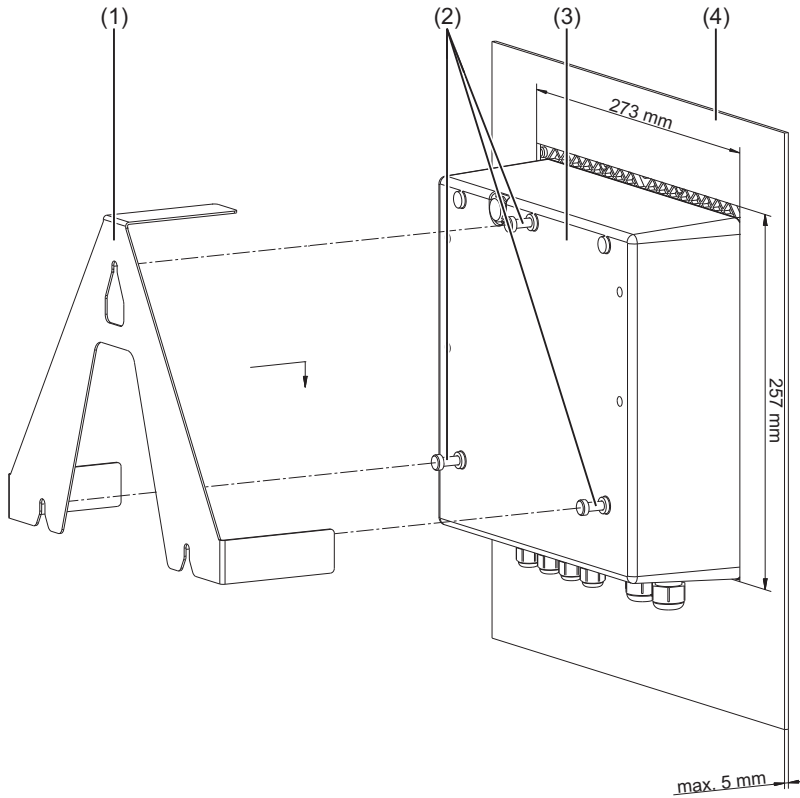

- (1) Fastening bracket from the panel mounting kit (part no. 00602403)
- (2) Self-tapping screws 60 × 16; TORX PLUS<sup>a</sup> 30IP (from the JUMO AQUIS touch S accessories pouch)
- (3) JUMO AQUIS touch S
- (4) Panel with device cutout 273 mm × 257 mm; max. material thickness of panel: 5 mm

<sup>a</sup> TORX PLUS<sup>®</sup> is a registered trademark of Acument Intellectual Properties, LLC, USA.

**JUMO GmbH & Co. KG**  
 Delivery address: Mackenrodtstraße 14  
 36039 Fulda, Germany  
 Postal address: 36035 Fulda, Germany  
 Phone: +49 661 6003-0  
 Fax: +49 661 6003-607  
 E-mail: mail@jumo.net  
 Internet: www.jumo.net

**JUMO Instrument Co. Ltd.**  
 JUMO House  
 Temple Bank, Riverway  
 Harlow, Essex CM20 2DY, UK  
 Phone: +44 1279 635533  
 Fax: +44 1279 635262  
 E-mail: sales@jumo.co.uk  
 Internet: www.jumo.co.uk

**JUMO Process Control, Inc.**  
 6733 Myers Road  
 East Syracuse, NY 13057, USA  
 Phone: 315-437-5866  
 1-800-554-5866  
 Fax: 315-437-5860  
 E-mail: info.us@jumo.net  
 Internet: www.jumousa.com



## Typical applications

### Cooling tower control

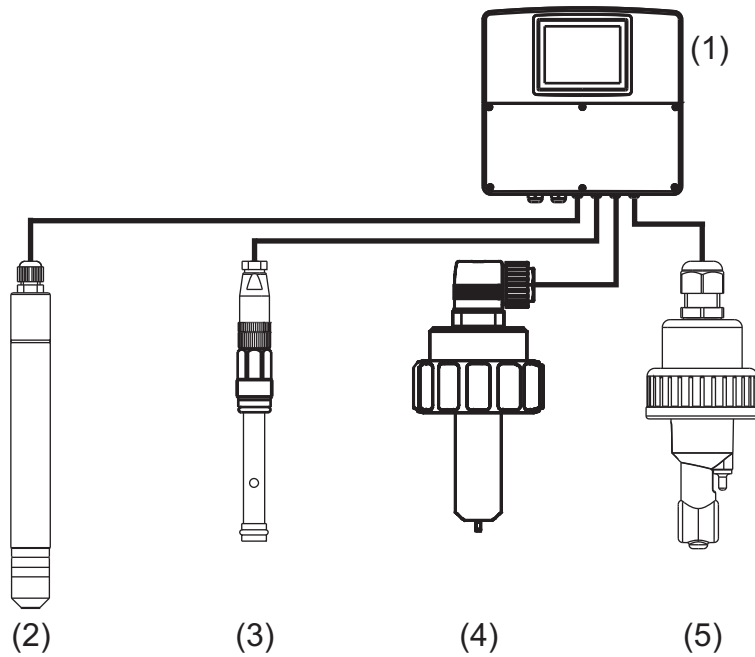

- (1) JUMO AQUIS touch S
- (2) Chlorine electrode (tecLine)
- (3) Flow monitor
- (4) Impeller sensor for flow measurement, type 406020
- (5) Conductivity sensor (inductive)

### Drinking water monitoring

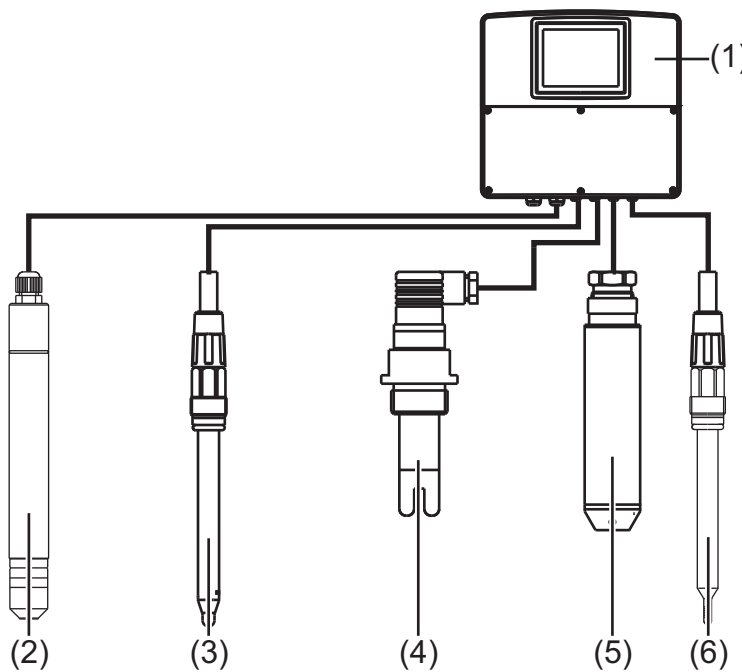

- (1) JUMO AQUIS touch S
- (2) Chlorine electrode (tecLine)
- (3) pH-single rod measuring chain
- (4) Conductivity sensor (conductive)
- (5) Level measurement probe
- (6) Compensation thermometer, type 201085

**JUMO GmbH & Co. KG**  
 Delivery address: Mackenrodtstraße 14  
 36039 Fulda, Germany  
 Postal address: 36035 Fulda, Germany  
 Phone: +49 661 6003-0  
 Fax: +49 661 6003-607  
 E-mail: mail@jumo.net  
 Internet: www.jumo.net

**JUMO Instrument Co. Ltd.**  
 JUMO House  
 Temple Bank, Riverway  
 Harlow, Essex CM20 2DY, UK  
 Phone: +44 1279 635533  
 Fax: +44 1279 635262  
 E-mail: sales@jumo.co.uk  
 Internet: www.jumo.co.uk

**JUMO Process Control, Inc.**  
 6733 Myers Road  
 East Syracuse, NY 13057, USA  
 Phone: 315-437-5866  
 1-800-554-5866  
 Fax: 315-437-5860  
 E-mail: info.us@jumo.net  
 Internet: www.jumousa.com



## Order details

		Expansion slot
<b>(1) Basic type</b>		
202581	JUMO AQUIS touch S	
<b>(2) Version</b>		
8	Standard with factory settings	
9	Customer-specific configuration (specification in plain text)	
<b>(3) Language</b>		
01	German	
02	English	
03	French	
<b>(4) Analysis input 1</b>		<b>IN 7</b>
0	Not used	
1	pH/Redox/NH <sub>3</sub>	
2	CR conductive conductivity measurement (2 and 4-pole)	
3	Ci inductive conductivity measurement	
<b>(5) Analysis input 2</b>		<b>IN 8</b>
0	Not used	
1	pH/Redox/NH <sub>3</sub>	
2	CR conductive conductivity measurement (2 and 4-pole)	
3	Ci inductive conductivity measurement	
<b>(6) Analysis input 3</b>		<b>IN 9</b>
0	Not used	
1	pH/Redox/NH <sub>3</sub>	
2	CR conductive conductivity measurement (2 and 4-pole)	
3	Ci inductive conductivity measurement	
<b>(7) Analysis input 4</b>		<b>IN 10</b>
0	Not used	
1	pH/Redox/NH <sub>3</sub>	
2	CR conductive conductivity measurement (2 and 4-pole)	
3	Ci inductive conductivity measurement	
<b>(8) Input/output 1</b>		<b>IN 11, OUT 6/7</b>
00	Not used	
10	Universal input	
11	Relay (changeover contact)	
12	2x relays (normally open contact)	
13	Solid state relay Triac 230 V, 1 A	
14	Logic output 0/22 V	
15	2x logic outputs 0/12 V	
16	Analog output	
17	2x solid state relays PhotoMOS <sup>®a</sup>	
<b>(9) Input/output 2</b>		<b>IN 12, OUT 8/9</b>
00	Not used	
10	Universal input	
11	Relay (changeover contact)	
12	2x relays (normally open contact)	
13	Solid state relay Triac 230 V, 1 A	
14	Logic output 0/22 V	
15	2x logic outputs 0/12 V	
16	Analog output	
17	2x solid state relays PhotoMOS <sup>®a</sup>	

**JUMO GmbH & Co. KG**

Delivery address: Mackenrodtstraße 14  
36039 Fulda, Germany  
Postal address: 36035 Fulda, Germany  
Phone: +49 661 6003-0  
Fax: +49 661 6003-607  
E-mail: mail@jumo.net  
Internet: www.jumo.net

**JUMO Instrument Co. Ltd.**

JUMO House  
Temple Bank, Riverway  
Harlow, Essex CM20 2DY, UK  
Phone: +44 1279 635533  
Fax: +44 1279 635262  
E-mail: sales@jumo.co.uk  
Internet: www.jumo.co.uk

**JUMO Process Control, Inc.**

6733 Myers Road  
East Syracuse, NY 13057, USA  
Phone: 315-437-5866  
1-800-554-5866  
Fax: 315-437-5860  
E-mail: info.us@jumo.net  
Internet: www.jumousa.com



<b>(10) Input/output 3</b>		<b>IN 13/14/15, OUT 10/11</b>
00	Not used	
11	Relay (changeover contact)	
12	2x relays (normally open contact)	
13	Solid state relay Triac 230 V, 1 A	
14	Logic output 0/22 V	
15	2x logic outputs 0/12 V	
16	Analog output	
17	2x solid state relays PhotoMOS <sup>®a</sup>	
18	3x binary inputs	
<b>(11) Input/output 4</b>		<b>IN 16/17/18, OUT 12/13</b>
00	Not used	
11	Relay (changeover contact)	
12	2x relays (normally open contact)	
13	Solid state relay Triac 230 V, 1 A	
14	Logic output 0/22 V	
15	2x logic outputs 0/12 V	
16	Analog output	
17	2x solid state relays PhotoMOS <sup>®a</sup>	
18	3x binary inputs	
<b>(12) Output 5</b>		<b>OUT 14/15</b>
00	Not used	
11	Relay (changeover contact)	
12	2x relays (normally open contact)	
13	Solid state relay Triac 230 V, 1 A	
14	Logic output 0/22 V	
15	2x logic outputs 0/12 V	
16	Analog output	
17	2x solid state relays PhotoMOS <sup>®a</sup>	
19	Voltage supply output DC ±5 V, 24 V	
<b>(13) Output 6</b>		<b>OUT 16/17</b>
00	Not used	
11	Relay (changeover contact)	
12	2x relays (normally open contact)	
13	Solid state relay Triac 230 V, 1 A	
14	Logic output 0/22 V	
15	2x logic outputs 0/12 V	
16	Analog output	
17	2x solid state relays PhotoMOS <sup>®a</sup>	
<b>(14) Output 7</b>		<b>OUT 18/19</b>
00	Not used	
11	Relay (changeover contact)	
12	2x relays (normally open contact)	
13	Solid state relay Triac 230 V, 1 A	
14	Logic output 0/22 V	
15	2x logic outputs 0/12 V	
16	Analog output	
17	2x solid state relays PhotoMOS <sup>®a</sup>	
<b>(15) Voltage supply</b>		
23	AC 110 ... 240 V +10/-15 %; 48 ... 63 Hz	
25	AC/DC 20 ... 30 V; 48 ... 63 Hz	
<b>(16) Com2 interface</b>		<b>COM 2</b>
00	Not used	
54	RS422/485 Modbus RTU	
64	PROFIBUS-DP	

**JUMO GmbH & Co. KG**

Delivery address: Mackenrodtstraße 14  
36039 Fulda, Germany  
Postal address: 36035 Fulda, Germany  
Phone: +49 661 6003-0  
Fax: +49 661 6003-607  
E-mail: mail@jumo.net  
Internet: www.jumo.net

**JUMO Instrument Co. Ltd.**

JUMO House  
Temple Bank, Riverway  
Harlow, Essex CM20 2DY, UK  
Phone: +44 1279 635533  
Fax: +44 1279 635262  
E-mail: sales@jumo.co.uk  
Internet: www.jumo.co.uk

**JUMO Process Control, Inc.**

6733 Myers Road  
East Syracuse, NY 13057, USA  
Phone: 315-437-5866  
1-800-554-5866  
Fax: 315-437-5860  
E-mail: info.us@jumo.net  
Internet: www.jumousa.com



(17) Interface Com3		LAN
00	Not used	
08	Ethernet	
(18) Voltage output		
1	DC 12 V	
2	DC 24 V	
(19) Extra codes		
000	Without extra code	
213	Recording function	
214	Math and logic module	
269	USB host socket (IP67)	

<sup>a</sup> PhotoMOS® is a registered trademark of Panasonic.

Order code:  /  -  /  , ...<sup>a</sup>  
 Order example: 202581 / 8 - 01 - 1 - 2 - 0 - 0 - 10 - 10 - 13 - 13 - 11 - 11 - 11 - 23 - 64 - 00 - 1 / 213 , 214

<sup>a</sup> List all desired extra codes separated by commas.

## Accessories

Order code	Type	Part no.
703571 (20258x)/10	Universal input	00581159
703571 (20258x)/213	Activation of the recording function	00581176
703571 (20258x)/214	Activation of math and logic module	00581177
703571 (20258x)/11	Binary output relay (changeover contact)	00581160
703571 (20258x)/12	Binary outputs 2x relay (normally open contact)	00581162
703571 (20258x)/13	Solid state relay Triac 230 V, 1 A	00581164
703571 (20258x)/14	Logic output 0/22 V	00581165
703571 (20258x)/15	2x Logic output 0/12 V	00581168
703571 (20258x)/16	Analog output	00581169
703571 (20258x)/17	Binary outputs 2x solid state relays PhotoMOS® <sup>a</sup>	00581171
703571 (20258x)/54	Serial interface RS422/485 for Modbus RTU	00581172
703571 (20258x)/64	PROFIBUS-DP	00581173
703571 (20258x)/08	Ethernet	00581174
20258x/3	Analysis input Ci for conductivity, inductive	00584265
20258x/2	Analysis input CR for conductivity, conductive	00584263
20258x/1	Analysis input pH/Redox/NH <sub>3</sub>	00584264
20258x/18	Binary inputs 3x potential-free contact	00592962
20258x/19	Voltage supply output DC ±5 V, 24 V	00592963
	USB flash drive 2.0 (1 GB) <sup>b</sup>	00505592
	USB cable, A-connector to Mini-B-connector, length 3 m	00506252
	Full configuration kit, cable fittings	00597461
	Panel mounting kit	00602403
	Pipe-mounted kit	00602401
	Protective roof kit	00602504

<sup>a</sup> PhotoMOS® is a registered trademark of Panasonic.

<sup>b</sup> The indicated USB flash drive is tested and designed for industrial applications. No liability is assumed for other brands.