

JUMO AQUIS 500 pH

Transmitter/Controller for pH, ORP and
NH₃- (ammonia) concentration
Type 202560



B 20.2560.0
Operating Instructions



**WARNING:**

A sudden malfunction of the instrument, or one of the sensors connected to it, could potentially result in dangerous, imprecise dosing! Suitable preventive measures must be in place to prevent this from happening.



**Note:**

Please read these Operating Instructions before placing the instrument in operation. Keep the manual in a place which is accessible to all users at all times.

**Resetting the brightness of the LC display:**

If the brightness/contrast setting has been adjusted so that the display text is no longer legible, the basic setting can be restored as follows:

Switch off the supply voltage.

Switch on the supply voltage and immediately press and hold the  and  keys simultaneously.

Reset the language to "English":

If the language has been adjusted so that the display text is no longer comprehensible, use the Administrator password, 7485, to reset the language to "English":

Press the  key for longer than 3 seconds.

Press the  key once.

Briefly press the  key.

Enter 7485.

Briefly press the  key.

The required language can then be set in

ADMINISTR. LEVEL / PASSWORD / PARAMETER LEVEL / DISPLAY / LANGUAGE.

Contents

1	Typographical conventions	6
1.1	Warning signs	6
1.2	Note signs	6
2	Description	7
3	Identifying the instrument version	8
3.1	Nameplate	8
3.2	Type designation	9
3.3	Scope of delivery	9
3.4	Accessories (in delivery package)	10
3.5	Accessories (optional)	11
4	Electrical connection	12
4.1	Installation notes	12
4.2	Electrical isolation	13
4.3	General	14
4.4	Connection	14
4.5	Terminal assignments	19
4.6	ISFET-pH combination electrode according to data sheet 20.1050	21
5	Mounting	22
5.1	General	22
5.2	Surface mounting	22
5.3	Pipe installation set / weather protection roof	23
5.4	DIN rail installation set	23
5.5	Mounting in a panel	24
6	Operation	26
6.1	Controls	26
6.2	LC display	27
6.3	Principle of operation	28
6.4	Measurement mode	31
6.5	Input/output information	31
6.6	MANUAL mode / simulation mode	33
6.7	HOLD mode	37
6.8	Operator level	38
6.9	Administrator level	38
6.10	Device info	44
6.11	Controller function	44

Contents

7	Commissioning	46
7.1	Fast start	46
7.2	Setup examples	47
8	Calibration	68
8.1	pH electrode	68
8.2	pH antimony electrode	76
8.3	ORP electrode	76
8.4	Ammonia (NH ₃)- cell	80
9	Setup program	82
9.1	Function	82
10	Eliminating faults and malfunctions	83
10.1	Possible faults	83
11	Appendix	84
11.1	Operator level parameters	84
11.2	Parameter explanations	90
11.3	Glossary	94
12	Instrument description	98
12.1	Technical data	98
12.2	Panel cut-out	101

Ziffern

- 1-point calibration 43
- 1-point calibration, ammonia 80
- 1-point calibration, pH 68, 76, 78
- 2-point calibration 43
- 2-point calibration, pH 70
- 3-point calibration 43
- 3-point calibration, pH 72

A

- Accessories 10–11
- Acidity errors 43
- Administrator level 38
- Administrator rights 40
- Alkaline errors 43
- Asymmetrical connection 16–17, 19, 94–95

B

- Basic settings 42
- Block diagram 7

C

- Cable routing 15
- Cell zero point 43
- Conductor cross-sections 12

D

- Date of manufacture 8
- Device info 44

E

- Electrical connection 12
- Electrical isolation 13, 82
- Enable level 40

F

- Fast start 46
- Fixing brackets 22

H

- HOLD mode 37

I

- Inputs 19
- Installation position 22
- ISFET sensor 21, 95, 99

L

- Logbook 44

M

- MANUAL mode 33
- MANUAL mode for analog outputs 36
- MANUAL mode for switching outputs 33

- Measurement mode 27, 31
- MIN/MAX values 31
- Mounting location 22

N

- Nameplate 8
- Normal display 27, 31

O

- Operator level 38
- Output level display 32
- Outputs 20
- Overview of MANUAL mode 34

P

- Panel mounting 24
- Parameter level 40
- Password 38
- Pipe 23
- Pipe installation 23
- Principle of operation 28

S

- Scope of delivery 9
- Sensor connection 16–18
- Setup examples 47
- Setup interface 82
- Simulation mode 33
- Simulation of switching outputs 35
- Slope 43
- slope 86
- Sunlight 22
- Supply 19, 21
- Surface 22
- Surface mounting 22
- switching function 90
- Symmetrical connection 18–19

T

- Terminal assignments 19
- Type designation 9

W

- Wash timer 97
- Weather protection roof 23

Z

- zero point 86
-

1 Typographical conventions

1.1 Warning signs



Danger

This symbol is used when there may be **danger to personnel** if the instructions are disregarded or not followed accurately!



Caution

This symbol is used when there may be **damage to equipment or data** if the instructions are ignored or not followed accurately!



Caution

This symbol is used where special care is required when handling components liable to damage through electrostatic discharge.

1.2 Note signs



Note

This symbol is used when your **special attention** is drawn to a remark.

abc¹

Footnote

Footnotes are remarks that **refer to specific points** in the text. Footnotes consist of two parts:

A marker in the text, and the footnote text.

The markers in the text are arranged as continuous superscript numbers.

*

Action instruction

This symbol indicates that an **action to be performed** is described.

The individual steps are marked by this asterisk.

Example:

* Remove crosspoint screws.

2 Description

General

The instrument is used for measuring/controlling the pH, ORP or NH₃- (ammonia) concentration. The function is switchable on the instrument itself. Depending on the measured variable, combination electrodes (e. g. pH/ORP combination electrodes, gas-sensitive sensors) or split versions (glass/metal electrodes with a separate reference electrode) can be readily connected. Temperature serves as the second input variable, measured by a Pt100/1000 probe, for example. It is therefore possible to implement automatic temperature compensation for the pH and NH₃ variables.

The instruments are operated using unambiguous keys and a large LC graphics display on which the measurements are clearly legible. The plain-text presentation of the parameters makes it easier for the user to configure the instrument, and also helps in programming it correctly.

Thanks to its modular design, the instrument can be perfectly matched to the specific application requirements. Up to four outputs are available (see the block diagram for the functions).

Typical areas of application

Universal application in water and wastewater engineering, service/process water and wastewater, drinking water and well/surface water, leakage monitoring in refrigeration plant.

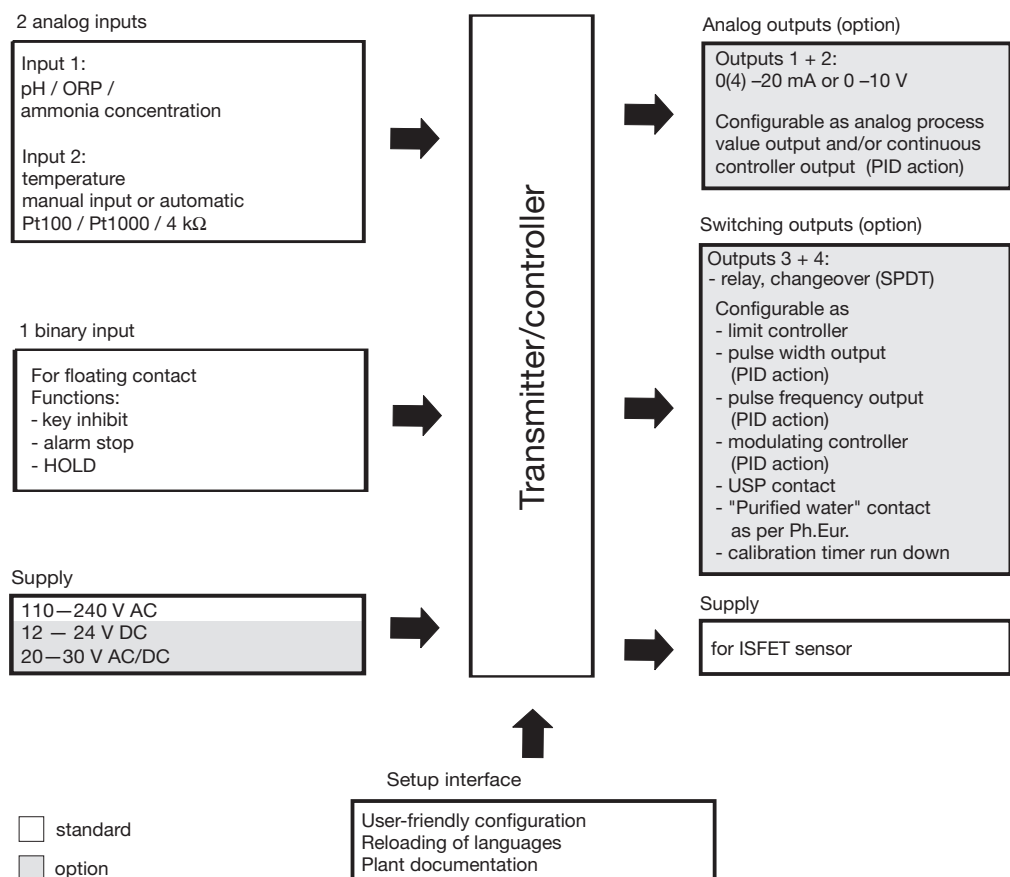

Block diagram



3 Identifying the instrument version

3.1 Nameplate

on the
transmitter

JUMO AQUIS 500 pH VARTN: 20/00491200
Typ: 202560/10-888-000-000-000-23/000 
F-Nr.: 0168122901012150001
~ AC 110..240V -15/+10% 48..63Hz < 14VA  



The date of manufacture is coded in the “F-Nr.” (serial number):
0935 means manufactured in year 2012 / week 15

3 Identifying the instrument version

3.2 Type designation

- (1) Basic type**
202560 JUMO AQUIS 500 pH
Transmitter/controller for pH, ORP,
NH₃- (ammonia) concentration and temperature
- (2) Basic type extensions**
10 for panel mounting
20 in surface-mountable housing
- (3) Output 1 (for principle measurement variable or continuous controller)**
000 no output
888 analog output 0(4) – 20 mA or 0 – 10 V
- (4) Output 2 (for temperature measurement variable or continuous controller)**
000 no output
888 analog output 0(4) – 20 mA or 0 – 10 V
- (5) Output 3**
000 no output
310 relay with changeover (SPDT) contact
- (6) Output 4**
000 no output
310 relay with changeover (SPDT) contact
- (7) Supply voltage**
23 110 – 240 V AC +10%/-15%, 48 – 63 Hz
25 20 – 30 V AC/DC, 48 – 63 Hz
30 12 – 24 V DC ±15%
- (8) Extra codes**
000 none

Order code (1) / (2) - (3) - (4) - (5) - (6) - (7) / (8)
 / - - - - - - /
Order example 202560 / 20 - 888 - 000 - 310 - 000 - 23 / 000

3.3 Scope of delivery

- Transmitter/controller
 - 1 bag with accessories
 - Operating Instructions
-

3 Identifying the instrument version

3.1 Accessories (in delivery package)

Contents

Designation



3 x plug-in screw terminals

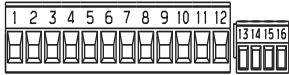

1 x large plug-in link



1 x small plug-in link



1 x cable clip for cable diameter > 5 mm



2 x cable clips for cable diameter < 5 mm



1 x cable clip for cable diameter < 3 mm



2 x pan head screws 3.5x6.5



4 x round spacers for panel mounting



4 x hexagonal nuts for panel mounting



4 x countersunk screws M6x10

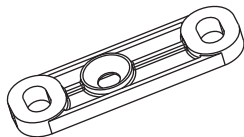

4 x fixings

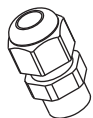

1 x cable gland M12x1.5



1 x sealing ring for cable gland M12x1.5



1 x reducing sealing ring for cable gland M12x1.5

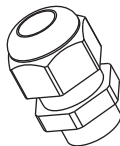

2 x cable glands M16x1.5



2 x sealing rings for cable gland M16x1.5



1 x multiple seal for cable gland M16x1.5

3 Identifying the instrument version

3.4 Accessories (optional)

Type	Part no.
Protection canopy for JUMO AQUIS 500 ¹	00398161
Pole-mounting kit for JUMO AQUIS 500 ²	00483664
Support pillar with pedestal base, arm and chain	00398163
PC setup software	00483602
PC interface, including USB/TTL converter and adapter (USB connecting cable)	00456352
Fixing for suspended fitting	00453191

¹ The pole-mounting kit is needed for mounting the protection canopy.

² Using the pole-mounting kit, the JUMO AQUIS 500 can be fitted to a pole (e.g. support pillar or railing).

4 Electrical connection

4.1 Installation notes



The electrical connection must only be carried out by qualified professional persons !

- The choice of cable, the installation and the electrical connection must conform to the requirements of VDE 0100 "Regulations on the Installation of Power Circuits with Nominal Voltages below 1000 V" or the appropriate local regulations.
- If contact with live parts is possible while working on the device, it must be completely disconnected from the electrical supply.
- Load circuits must be fused for the maximum relay current in each case, in order to prevent welding of the relay contacts in the event of a short circuit.
- The electromagnetic compatibility conforms to EN 61326.
- Run input, output and supply cables separately and not parallel to one another.
- Uses shielded sensor cables with twisted conductors. Do not run these cables close to current-carrying components or cables. Ground shielding at one end.
- Sensor leads should be implemented as uninterrupted cables (not routed via terminal blocks etc.).
- Do not connect any additional loads to the supply terminals of the instrument.
- The instrument is not suitable for use in areas with an explosion hazard (Ex areas).
- Apart from faulty installation, incorrect settings on the instrument may also affect the proper functioning of the subsequent process or lead to damage. Safety devices independent of the instrument should therefore always be provided and should only be capable of adjustment by specialist personnel.

Conductor cross-sections and core-end ferrules

Fitting sizes

	Minimum cross-section	Maximum cross-section	Min. length of core-end ferrule
Without core-end ferrule	0.34mm ²	2.5mm ²	10mm (stripped)
Core-end ferrule, no lip	0.25mm ²	2.5mm ²	10mm
Core-end ferrule, lip up to 1.5mm²	0.25mm ²	1.5mm ²	10mm
Core-end ferrule, lip above 1.5mm²	1.5mm ²	2.5mm ²	12mm
Twin ferrule with lip	0.25mm ²	1.5mm ²	12mm



The IP67 enclosure protection for the instrument will only be achieved if each cable is fed into the instrument through a cable gland.

4.2 Electrical isolation

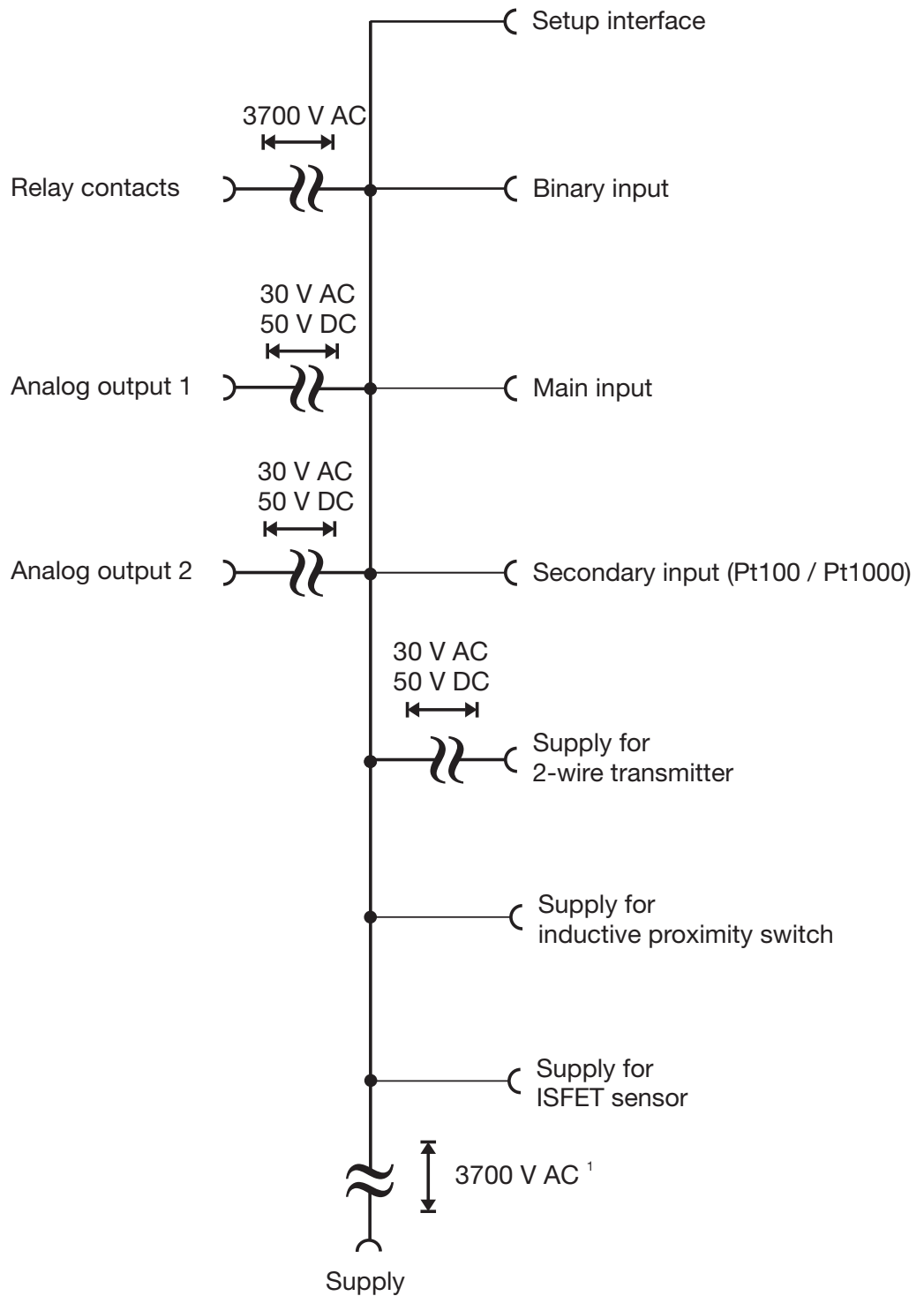

¹ Not with 12 – 24 VDC supply voltage

4 Electrical connection

4.3 General

Opening the instrument



- * Remove four screws (1) and swing down the top section.

4.4 Connection

4.4.1 pH combination electrode / ORP combination electrode

Fabricating the connecting cable

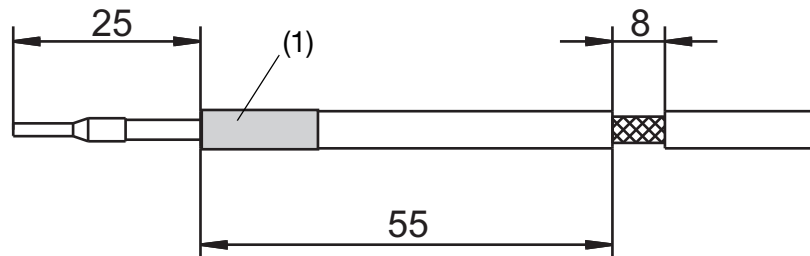

- * Strip the cable as shown in the diagram.
 - * Insulate the exposed shielding with a shrink-sleeve (1), to prevent short-circuits.
 - * Apply core ferrules to the ends of the conductors.
Core ferrule dimensions see Chapter 4.1 “Installation notes”, page 12.
-

4 Electrical connection

Connecting the cables

The electrical connection for the surface-mountable housing is easily accessible when the instrument is folded out.

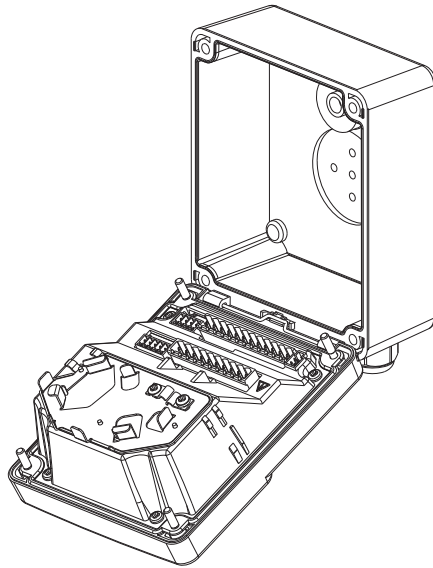

The connection cable between sensor and transmitter must be a shielded cable with a diameter of 8 mm max.

The instrument contains a guide plate that ensures an optimum cable path.

The sensor cables are run to the plug-in screw terminals and must have a strain relief.



The cable clip (3) must **only** be screwed down (see next page) by a 3.5x6.5 pan head screw! A longer screw may cause a hazardous voltage to be contacted to the shielding!

4 Electrical connection

Asymmetrical connection of a combination electrode (standard)

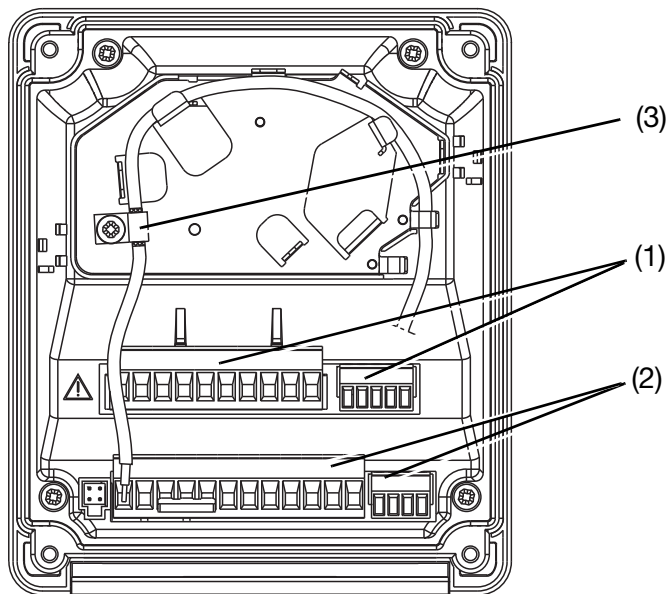

- * Lead the connecting cables in through the cable glands.
- * Lay the signal cable as shown in the diagram. Use the cable clip (3) to clamp the signal cable to the shielding.
- * Connect the cores as assigned below, and see Chapter 4.5 “Terminal assignments”, page 19.
- * Push the plug-in terminals for row 1 (1) and row 2 (2) into the sockets in the instrument.

Sensor connection

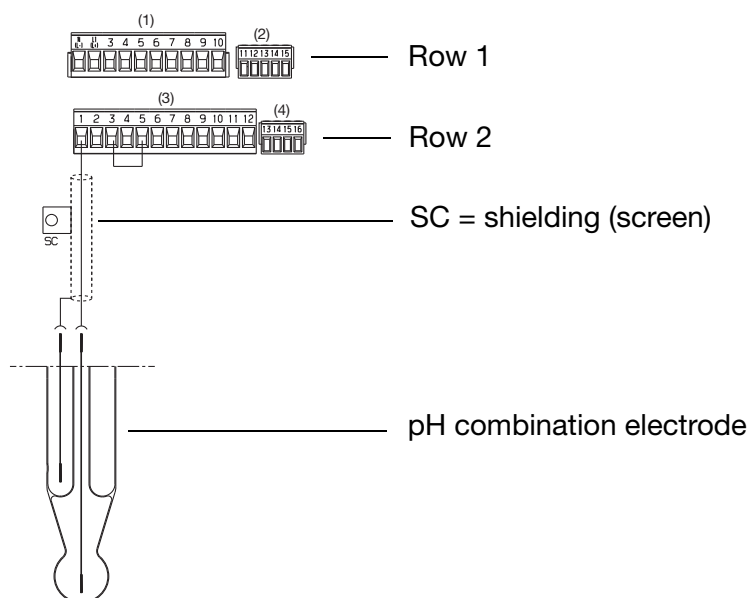

In environments with difficult EMC conditions, a coaxial cable with a double shielding must be used. A shielded 2-core cable is required for connecting the temperature probe.

4 Electrical connection

Asymmetrical connection of a combination electrode with integrated temperature sensor (SMEK)

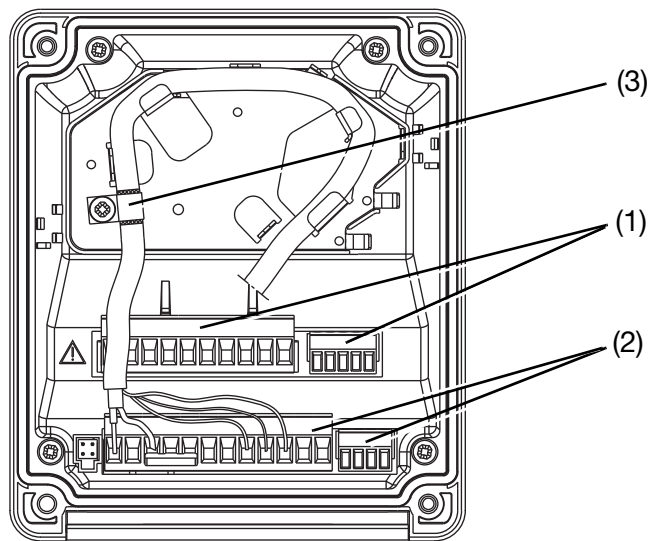

- * Lead the connecting cables in through the cable glands.
- * Lay the signal cable as shown in the diagram. Use the cable clip (3) to clamp the signal cable to the shielding.
- * Connect the cores as assigned below, and see Chapter 4.5 "Terminal assignments", page 19.
- * Push the plug-in terminals for row 1 (1) and row 2 (2) into the sockets in the instrument.

Sensor connection

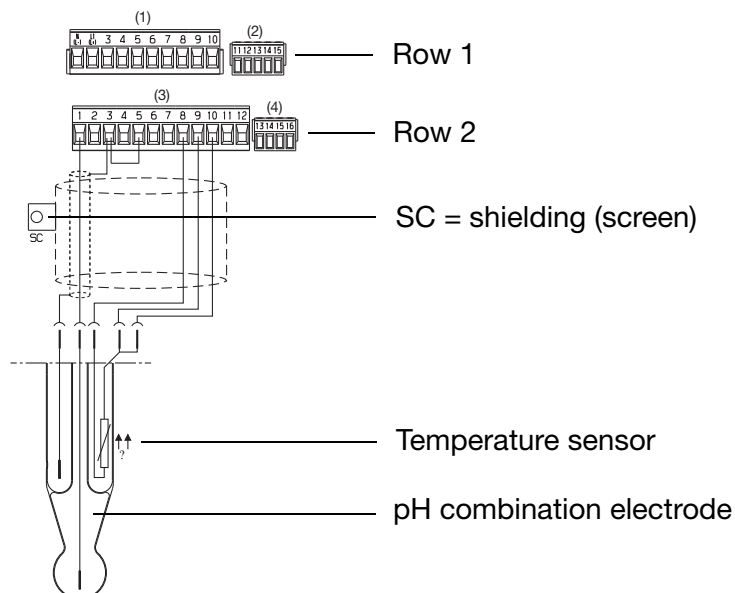

4 Electrical connection

Symmetrical connection of a combination electrode with separate temperature sensor

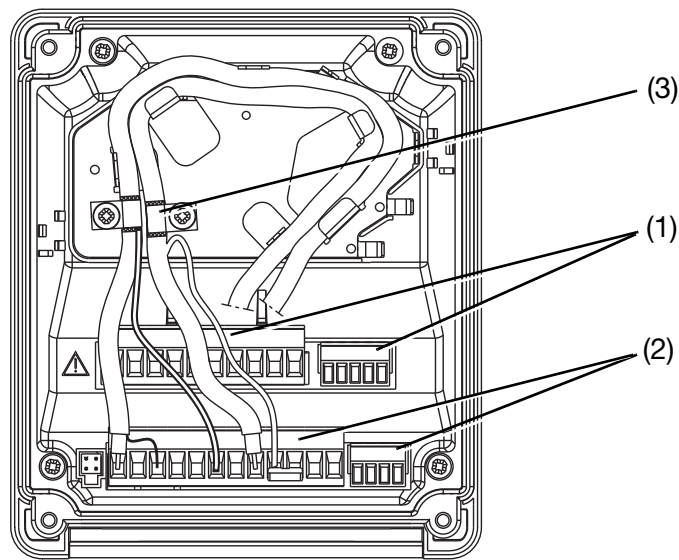

- * Lead the connecting cables in through the cable glands.
- * Lay the signal cables as shown in the diagram. Use the cable clips (3) to clamp each signal cable to the shielding.
- * Connect the cores as assigned below, and see Chapter 4.5 “Terminal assignments”, page 19.
- * Push the plug-in terminals for row 1 (1) and row 2 (2) into the sockets in the instrument.

Sensor connection

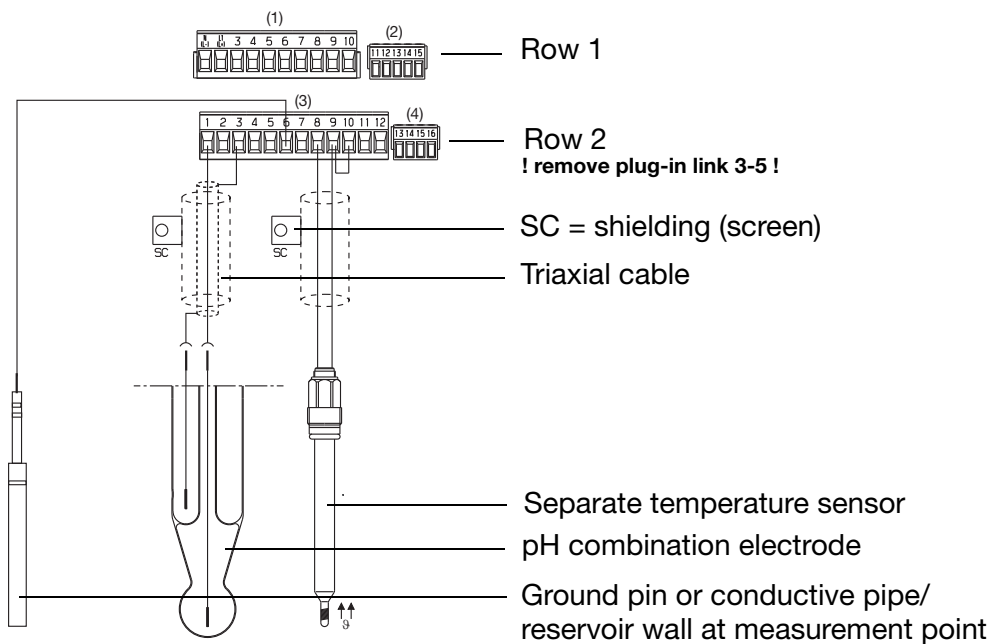

In environments with difficult EMC conditions, a coaxial cable with a double shielding must be used. A shielded 2-core cable is required for connecting the temperature probe.

4 Electrical connection

4.5 Terminal assignments

Connection		Screw terminals	Row
Supply voltage			
Supply voltage (23): 110 – 240 V AC -15/+10%, 48 – 63 Hz		1 N (L-) 2 L1 (L+)	1
Supply voltage (25): 20 – 30 V AC/DC, 48 – 63 Hz			
Supply voltage (30): 12 – 24 V DC +/-15% (permissible only for connection to SELV/PELV circuits)			
NC		3	
NC		7	
NC		14	
NC		15	
Inputs			
Glass/metal electrode		1	2
NC		2	
Reference electrode		3	
NC		4	
GND With asymmetrical connection for pH measurement Link terminals 3 and 5 (Accessory: large plug-in link)		5	
FP (liquid potential) With symmetrical connection for pH measurement		6	
NC		7	
RTD in 2-wire circuit (Accessory: small plug-in link)		8 9 10	
RTD in 3-wire circuit		8 9 10	
Binary input		11 12	

4 Electrical connection

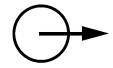
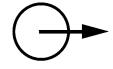
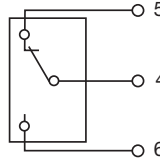
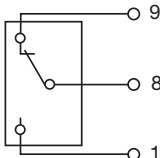
Connection	Screw terminals	Row
Outputs		
Analog output 1 0 – 20 mA resp. 20 – 0 mA or 4 – 20 mA resp. 20 – 4 mA or 0 – 10 V resp. 10 – 0 V (electrically isolated)		+ 13 - 14
Analog output 2 0 – 20 mA resp. 20 – 0 mA or 4 – 20 mA resp. 20 – 4 mA or 0 – 10 V resp. 10 – 0 V (electrically isolated)		+ 15 - 16
Switching output K1 (floating)		pole 4 break (SPST-NC) 5 make (SPST-NO) 6
Switching output K2 (floating)		pole 8 break (SPST-NC) 9 make (SPST-NO) 10

4 Electrical connection

4.6 ISFET-pH combination electrode according to data sheet 20.1050

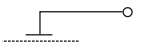
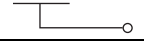
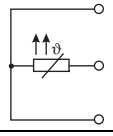
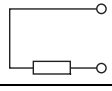
Connection		Color	Screw terminals	Row
		Cap-adapter	JUMO AQUIS 500 pH	
Supply voltage for ISFET sensor				
Supply voltage DC \pm 5 V, 5 mA	+  -	blue black green	11 L+ 12 \perp 13 L-	1
pH sensor				
Sensor		white / black	1	2
Reference		screen	3 + 5 linked	
RTD in 3-wire circuit		white red red / black	10 9 8	
Parallel resistance 4.53 kΩ				
only in conjunction with process connection 615!		red / black red	8 9	2



The orange core of the cap adapter is not connected!

The TEMPERATURE INPUT / SENSOR TYPE / CUSTOMIZED parameter must be configured for process connection 615!

5 Mounting

5.1 General

Mounting location

Find a location that ensures easy accessibility for the later calibration.
The fastening must be secure and must ensure low vibration for the instrument.

Avoid direct sunlight!

Permissible ambient temperature at the installation location: -10 to 55°C with max. 95% rel. humidity, no condensation.

Installation position

The instrument can be mounted in any position.

5.2 Surface mounting



Fixing brackets (1) are included with delivery.

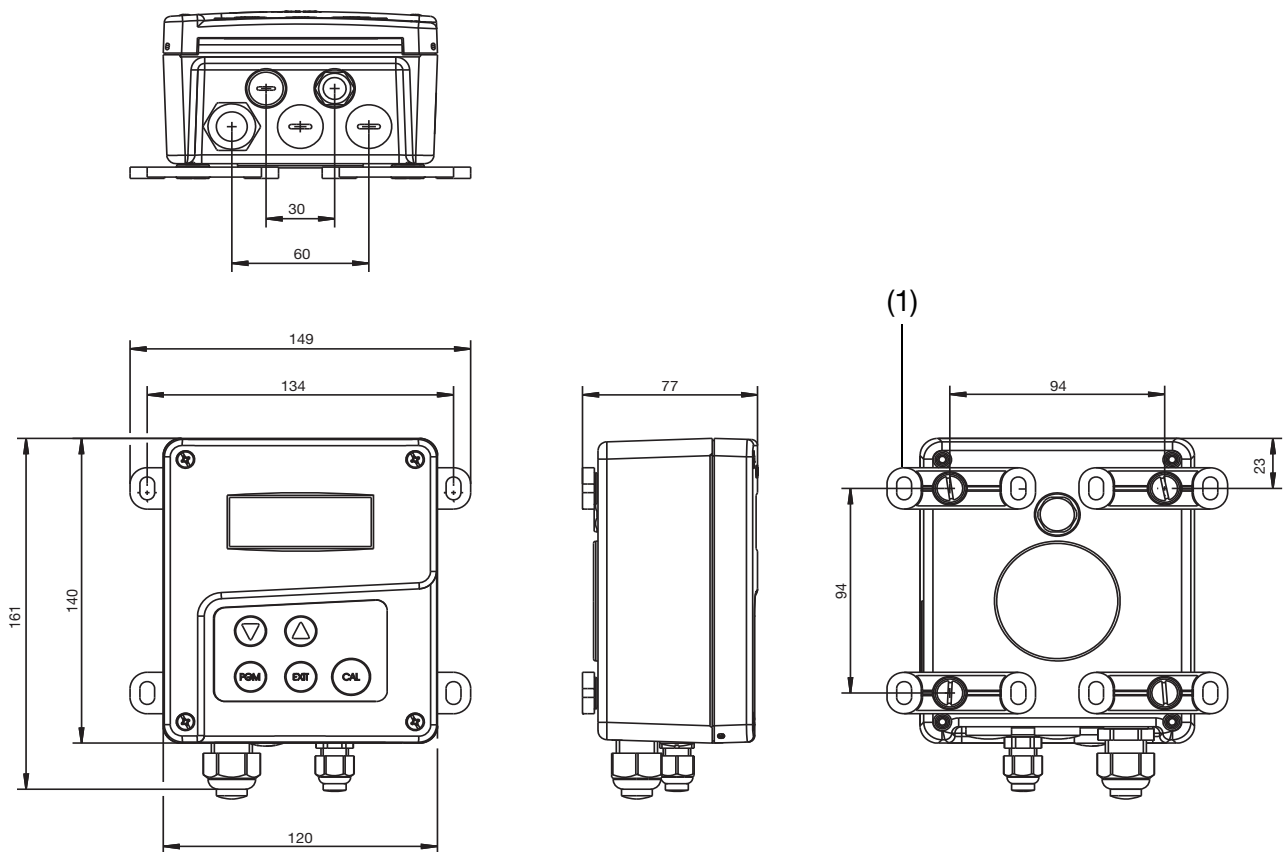

- * Screw four fixing brackets (1) onto the enclosure.
The fixing brackets can be turned in increments of 90°.
- * Fasten the enclosure onto the fixing brackets (with screws, plugs, etc.) on a surface or plate.

5.3 Pipe installation set / weather protection roof

The pipe installation set for JUMO AQUIS 500 (sales no.: 20/00483664) can be used to fasten the instrument (and optionally the protective roof for JUMO AQUIS 500, sales no.: 20/00398161) onto pipes or railings with a diameter from 30 to 50 mm.

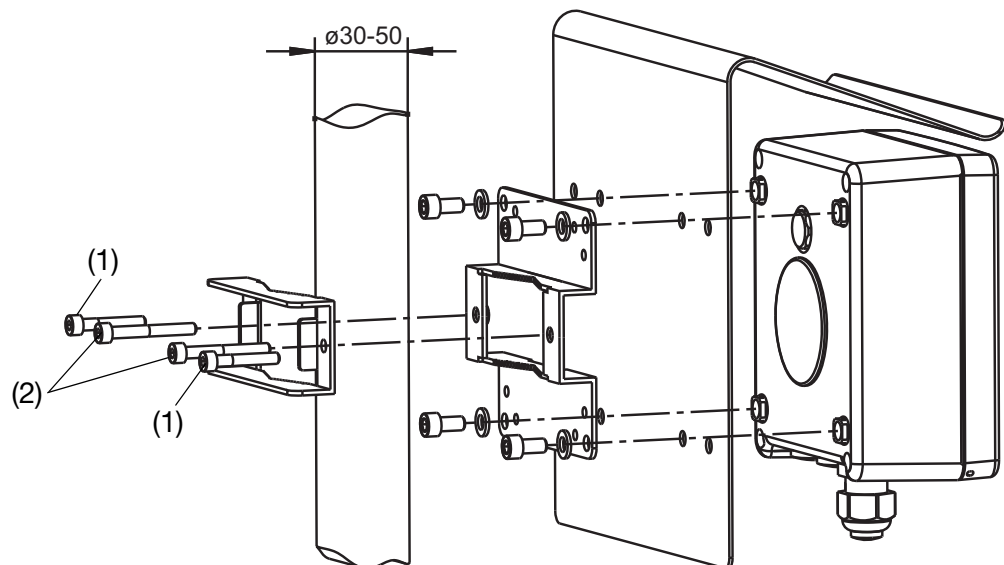

Screws (1) M5 x 30 for pipe diameters from 30 to 40 mm.

Screws (2) M5 x 40 for pipe diameters from 40 to 50 mm.

The pipe installation set is also suitable for horizontal pipes.

5.4 DIN rail installation set

The DIN rail installation set for JUMO AQUIS 500 (sales no.:20/00) can be used to attach the instrument to a 35 mm x 7.5 mm DIN rail as defined in DIN EN 60715 A.1.

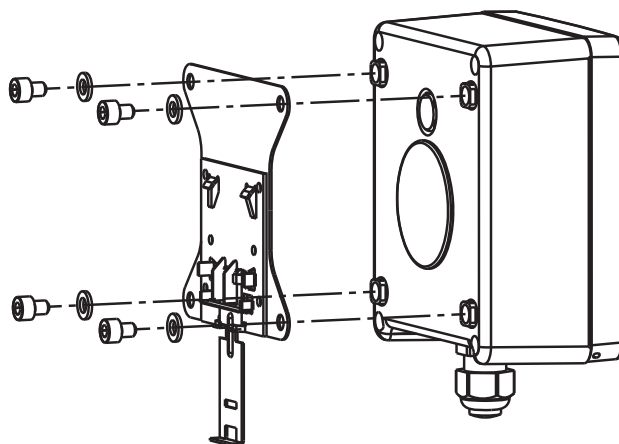

5 Mounting

5.5 Mounting in a panel



Drilling template See section 12.2 "Panel cut-out", page 101.

The panel must be sufficiently thick to achieve the specified IP65 enclosure protection!

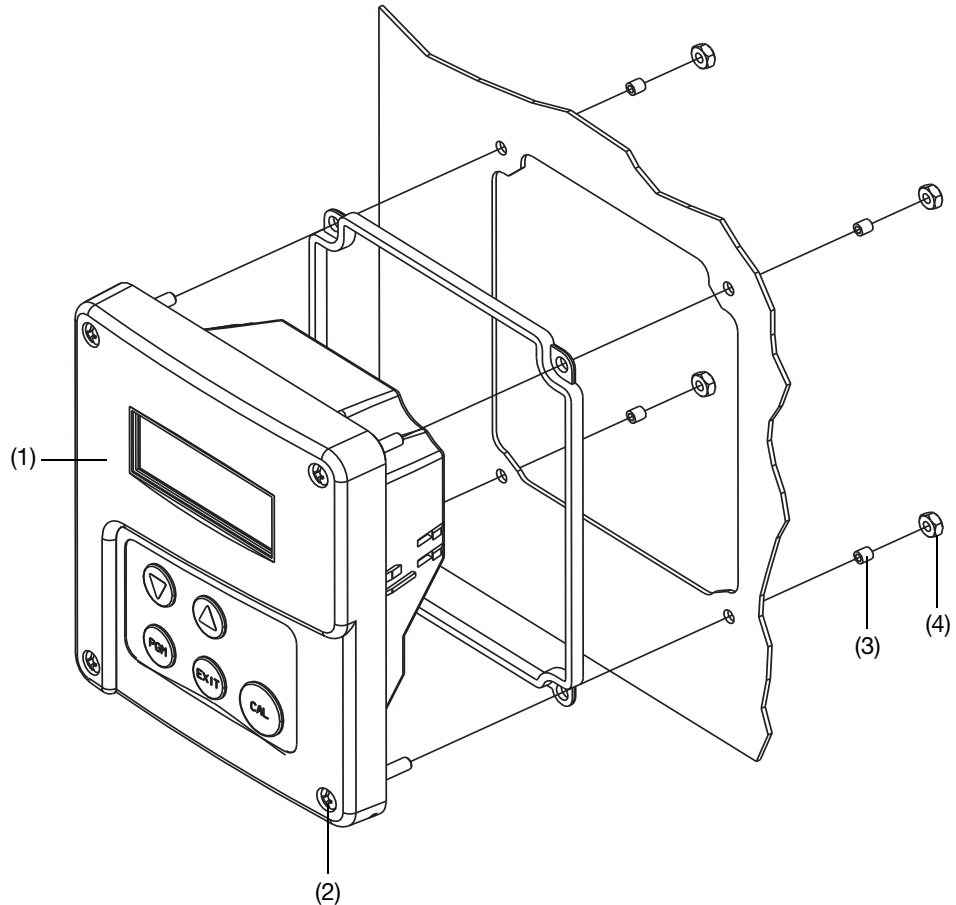

- * Prepare the panel cut-out and holes based on the drill template.
- * Place the control panel (1) in the panel cut-out and fasten it with screws (2) spacing rollers (3) and nuts (4).



To ensure electrical safety, the mounting set for panel installation (sales no.: 20/00530470) must be installed, see next page!

5 Mounting

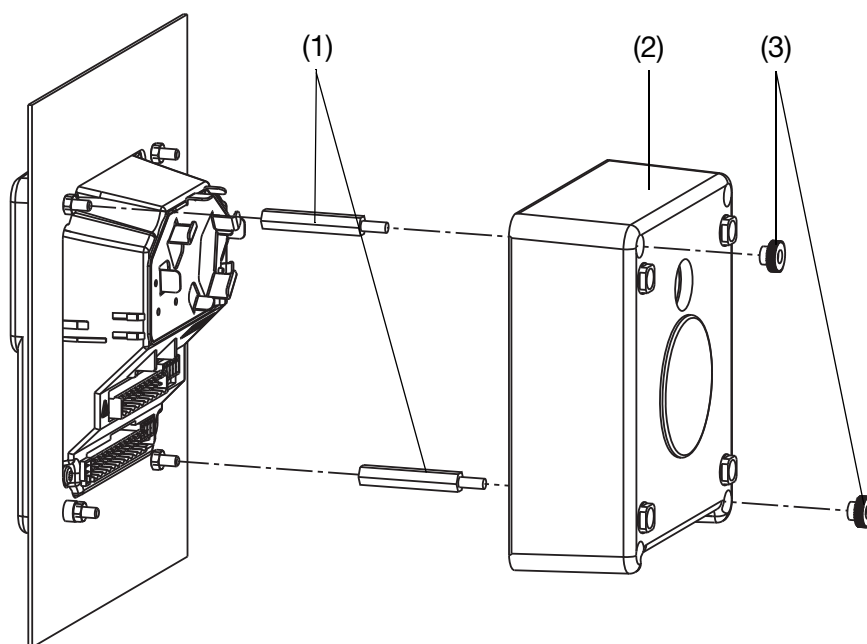

The mounting set (sales no.: 20/00530470) consists of parts (1), (2) and (3).

- * Make the electrical connection.
- * Screw on two stud bolts (1).
- * Fasten the cover (2) with two knurled nuts (3).

Depth behind panel

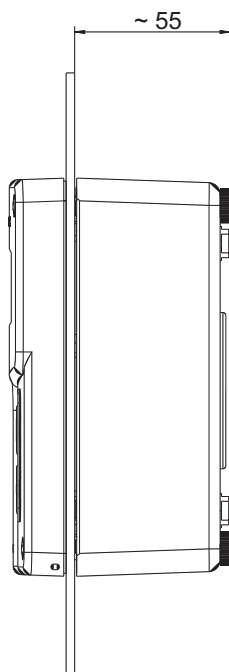

6 Operation

6.1 Controls

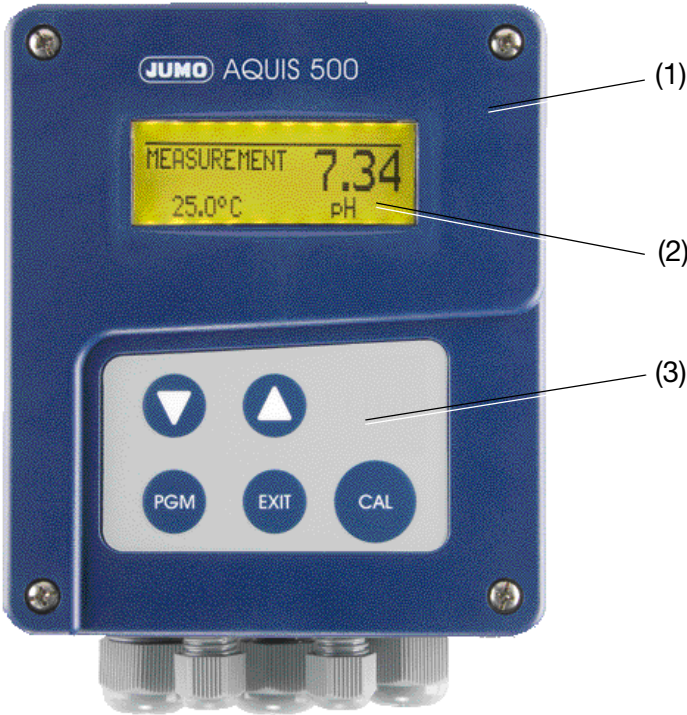

(1) Transmitter

(3) Control panel

(2) LC display

6.2 LC display

6.2.1 Measurement mode (normal display)

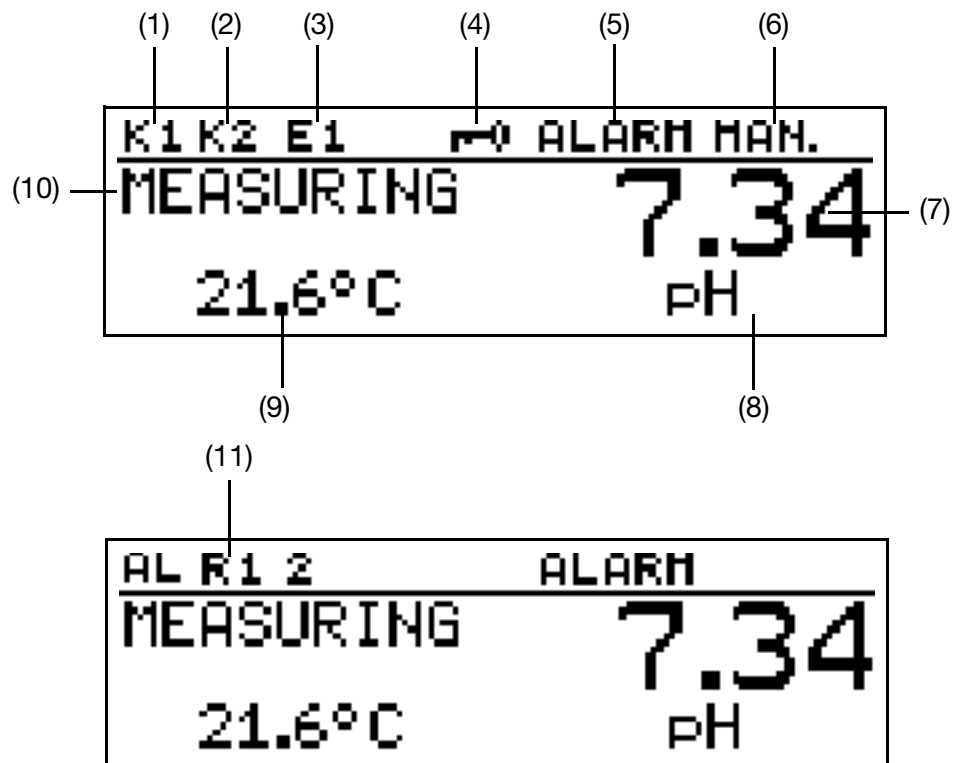

- | | |
|---|---|
| (1) Relay K1 is active | (6) Output mode
- Hand (manual operation)
- Hold (Hold operation) |
| (2) Relay K2 is active
or
AL R1 = alarm, relay K1
AL R2 = alarm, relay K2
ALR12 = alarm, relay K2+K2 | (7) Measurement |
| (3) Binary input 1 is activated | (8) Unit |
| (4) Keypad is inhibited | (9) Temperature of medium |
| (5) Device status (indications)
- Alarm (e.g overrange)
- Calib. blinking (calibration timer run down)
- Calib. (customer calibration is active) | (10) Operating mode |
| | (11) ALR1 = alarm, controller 1
ALR2 = alarm, controller 2
ALR12 = alarm, controllers 1 and 2 |



In order to return to the measurement mode from another display mode:
Press the **EXIT** key or wait for the timeout.

6 Operation

6.3 Principle of operation

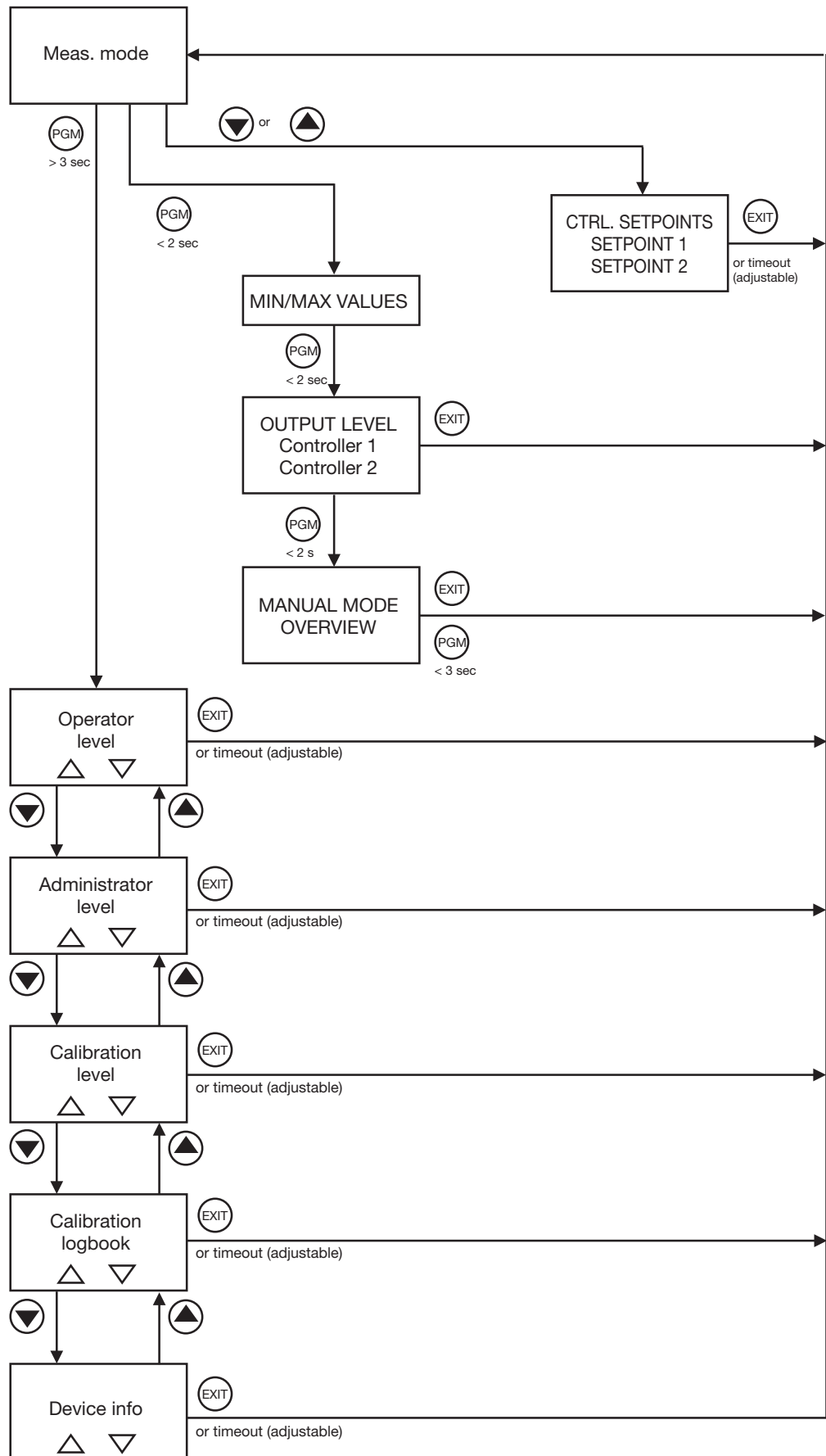

6.3.1 Operation in levels

Measurement mode (normal display); see Chapter 6.4 "Measurement mode", page 31

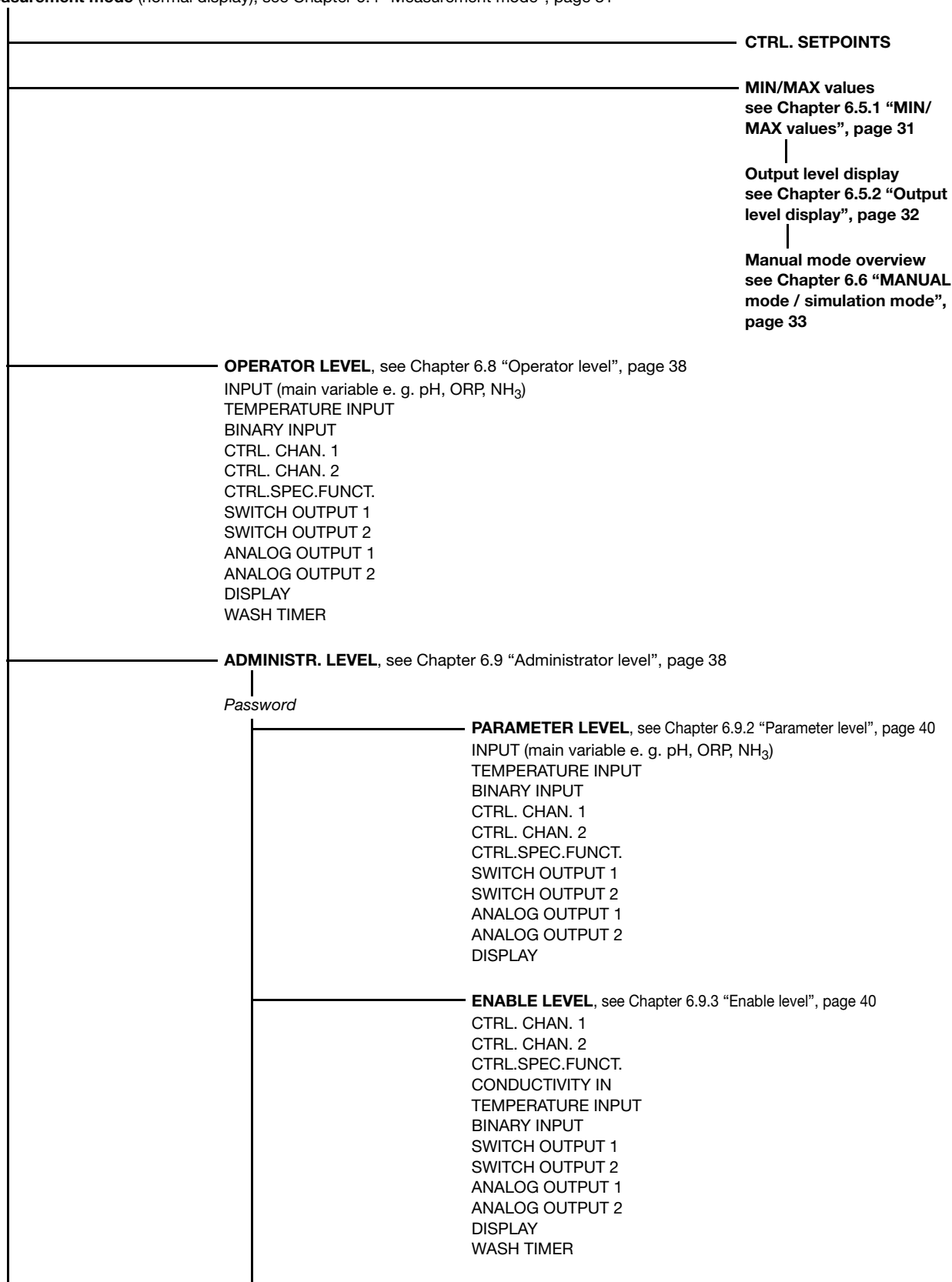

6 Operation

Measurement mode

ADMINISTRATOR LEVEL

BASIC SETTINGS, see Chapter 6.9.4 "Basic settings", page 42

SENSOR
MONIT. REF.
MONIT. GLASS EL.
RE-INITIALIZE DEVICE

CALIB. LEVEL, see Chapter 6.9.5 "Calibration level", page 43

1-POINT CALIB.
2-POINT CALIB.
3-POINT CALIB.

CALIB. ENABLE

ENABLE
1-POINT CALIB.
ENABLE
2-POINT CALIB.
ENABLE
3-POINT CALIB.

DELETE LOGBOOK

REALLY DELETE LOGBOOK?

CALIB. LEVEL

1-POINT CALIB.
2-POINT CALIB.
3-POINT CALIB.

CALIB. LOGBOOK

DEVICE INFO

SENSOR
MONIT. REF.
MONIT. GLASS EL.

6.4 Measurement mode

6.4.1 Normal display

Presentation The compensated pH value and temperature of the medium are shown in normal display.

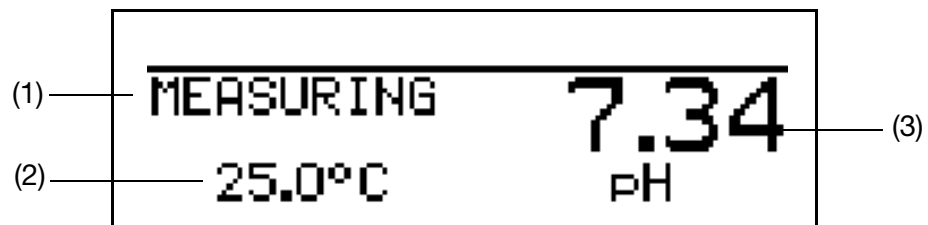

- (1) MEASURE -> Measurement mode
- (2) 25.0°C -> Temperature of the sample medium
- (3) 7.34 pH-> pH of the medium (compensated for the reference/ comparison temperature – usually 25°C)



In measurement mode, the display types “Trend display” and “Bar graph” can also be selected. see “MEAS. DISPLAY TYPE”, page 91

6.5 Input/output information

6.5.1 MIN/MAX values

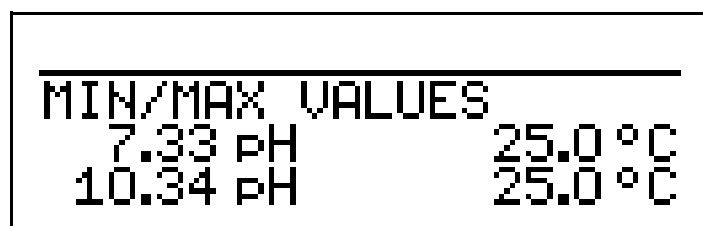

Activating the display of MIN/MAX values

The instrument is in the measurement mode (normal display).

- * Press the  key for less than 2 seconds. Minimum and maximum values of the pH, ORP or NH₃⁻ (ammonia) concentration and temperature are displayed.

6 Operation



The values for the main measurement and temperature are **not** allocated to one another (e. g. the max. value of the main variable was 7.33 pH and 25.0°C the max. temperature value).

In order to return to the measurement mode:

Press the **EXIT** key or wait for the timeout.

Measurements with overrange will be ignored.

Pressing the **PGM** key briefly again accesses the “Output level display” mode.

The MIN/MAX value memory can be reset: Operator level / Display / MIN/MAX value memory / Yes,

see Chapter 11.1 “Operator level parameters”, page 84ff.

If you change the basic setting, or in the event of a power-down, the MIN and MAX values will be deleted.

6.5.2 Output level display

```
OUTPUT LEVEL
CONTROLLER 1    0%
CONTROLLER 2    0%
```

The instrument is in the measurement mode (normal display).

* Press the **PGM** key for less than 2 seconds, twice.

The output level for the two controller contacts will be indicated (if they are fitted).



In order to return to the normal display:

Press the **EXIT** key or wait for the timeout.

Pressing the **PGM** key again will access the mode for “Manual mode overview”.

6.6 MANUAL mode / simulation mode

These functions can be used to set the switching outputs and analog outputs of the instrument manually to a defined state. This facilitates dry startup, troubleshooting and customer service.

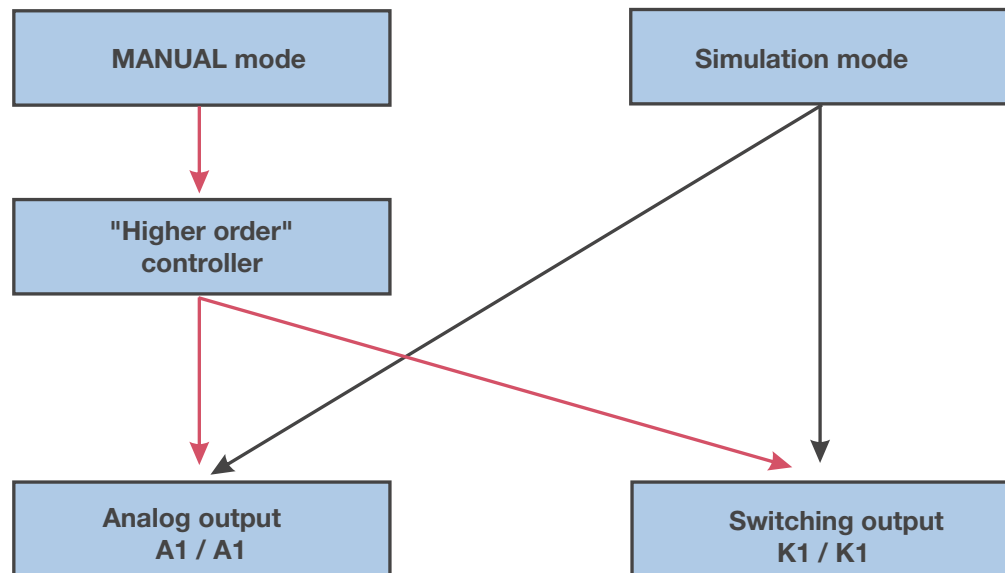

Simulation mode **directly** accesses switching outputs K1/2 or analog outputs 1/2. When simulation mode has been selected, MANUAL mode is **not** possible!

In MANUAL mode the settings for "higher order controllers" are taken into consideration.

6.6.1 MANUAL mode via "higher order control functions"

Higher order switching functions

The JUMO AQUIS 500 is configured for **higher order control functions** when the following setting is made:

User level / controller channel 1 or 2 / control type **Limit value or pulse length or pulse frequency or modulating or continuous controller**.

For the recommended procedure see Chapter 6.6.3 "Simulation of analog outputs via MANUAL mode", page 36.

In other configurations switching outputs K1 or K2 are switched.

Select manual mode





In the factory setting of the instrument the MANUAL mode parameter is disabled and can **only be activated by the administrator!**



This parameter must first be enabled for other users, see Chapter 6.9.3 "Enable level", page 40.

* Set to Administrator level / Password / Parameter level / Special controller functions / Manual mode locked, **Momentary action** or **Switching**.

6 Operation



Locked = No manual mode, control via JUMO AQUIS 500.

Momentary = the outputs are active as long as the  or  key is pressed.
action



Switching = the outputs are active if the  or  key is pressed. If the corresponding key is pressed again, the output becomes inactive again.

Activate manual mode



The instrument is in display mode

* Press the  and  keys for less than 2 seconds.
The word MANUAL appears in the status line of the display.



If the  and  keys are pressed for longer than 3 seconds, the instrument goes into HOLD mode.

Then the outputs of the instrument respond according to the default settings.

To exit HOLD mode, press the  and  keys for longer than 3 seconds.

Control is no longer through the JUMO AQUIS 500. The output level of the controller channels is 0%.

Controller channel 1 is activated by the  key. In this case the output level of controller channel 1 is 100%.

Controller channel 2 is activated by the  key. In this case the output level of controller channel 2 is 100%.

Deactivation

* Press the  key.

Control is once again through the outputs of the instrument.
The word MANUAL appears in the status line of the display.

Overview of MANUAL/ Simulation mode

You can display which outputs and/or controllers are in MANUAL mode.
The instrument is in "normal display" mode.

Press the  key several times for less than 2 seconds (the number of times varies depending on the equipment and configuration of the instrument).

			MAN.
SWITCH. OUT		---	
ANALOG OUT		---	
CONTROLLER	1+2	MAN.	

Output level of controller channels

The instrument is in "normal display" mode

Press the  key several times for less than 2 seconds (the number of times varies depending on the equipment and configuration of the instrument).

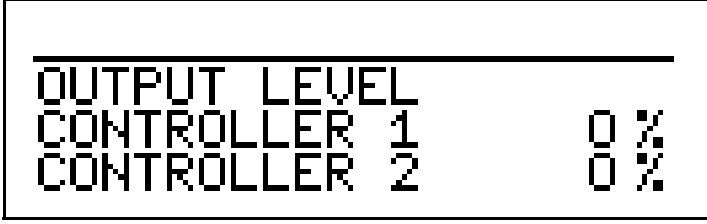

```
OUTPUT LEVEL
CONTROLLER 1    0%
CONTROLLER 2    0%
```

The display changes when the  key or the  key is pressed.







To return to measuring mode:
press the  key or wait for a "timeout".

6.6.2 Simulation of switching outputs

Simple witching functions

The switching outputs are configured when the following setting is made:
Operator level / Controller channels 1 and/or 2 / Controller type **Off**
and

Switching output 1 or 2 / function  or  or  or .

Activate simulation



In the factory setting of the instrument the MANUAL mode parameter is set to "No simulation" and can **only be activated by the administrator!**
This parameter must first be enabled for other users, see Chapter 6.9.3 "Enable level", page 40.

* Set Administrator level / Password / Parameter level / Switching output 1 or 2 / Manual mode no simulation, **Inactive** or **Active**.

No simulation = No manual mode, control is via the JUMO AQUIS 500.

Inactive = Relay K1 or K2 is de-energized.

Active = Relay K1 or K2 is energized.

Deactivate manual mode

No simulation = No manual mode, control via JUMO AQUIS 500.

6 Operation

6.6.3 Simulation of analog outputs via MANUAL mode

Enabling and activation

- * Select activation of simulation of the actual value output:
Administrator level / Password / Parameter level / Analog output 1 or 2 / Simulation / Off or **On**.

With "On" the output takes on the value of the "Simulation value" parameter.
When the JUMO AQUIS is in display mode, the word MANUAL appears in the status line of the display.

Deactivation

- * Administrator level / Password / Parameter level / Analog output 1 or 2 / Simulation / Off.

The corresponding output of the JUMO AQUIS 500 works again.
When the JUMO AQUIS is in display mode, the word MANUAL disappears from the status line of the display.

6.6.4 MANUAL/Simulation overview

You can display which outputs and/or controllers are in MANUAL mode.
The instrument is in "normal display" mode

Press the  key several times for less than 2 seconds (the number of times varies depending on the equipment and configuration of the instrument).

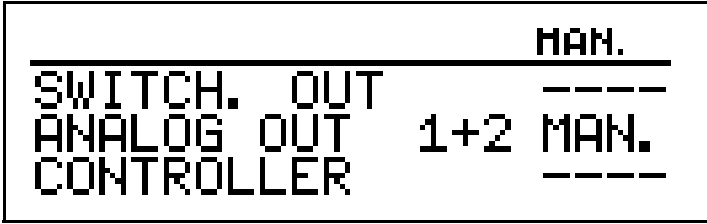

	MAN.
SWITCH. OUT	----
ANALOG OUT 1+2	MAN.
CONTROLLER	----



To return to measuring mode:
press the  key or wait for a "timeout".

6.7 HOLD mode

In HOLD status the outputs take on the states programmed in the relevant parameter (controller channel, switching output or analog output).

This function can be used to "freeze" switching outputs and the analog outputs of the instrument. This means the current status of the output will be retained even when the measured value changes. Control is not via the instrument.



If MANUAL mode is activated while HOLD mode is activated, MANUAL mode takes precedence and MANUAL then appears in the status line of the display! MANUAL mode can be terminated by pressing the key.

If HOLD mode is still activated (by the binary input or by keyboard), the instrument then returns to HOLD mode!

HOLD mode can be activated by pressing the key or by the binary input.

Activation by pressing key

- * Press and hold the and keys longer than 3 seconds. Then the outputs of the instrument respond according to the default settings. The word HOLD appears in the status line of the display.



If the and keys are pressed for less than 3 seconds, the instrument goes into manual mode.

Then the outputs of the instrument respond according to the default settings.

Pressing a key to deactivate HOLD mode

- * Press the and keys for longer than 3 seconds.



If the and keys are pressed for less than 3 seconds, the instrument goes into Manual mode.

Then the outputs of the instrument respond according to the default settings.

Control is through the outputs of the instrument again. The word MANUAL disappears from the status line of the display.

6 Operation

6.8 Operator level

All the parameters that have been enabled by the administrator (Administrator level, see “Administrator level”, page 38) can be edited in this level. All other parameters (marked by a key ) can only be read.

- * Press the  key for longer than 3 seconds.
- * Select OPERATOR LEVEL.









For operator level parameters and their explanations, see Chapter 11.1 “Operator level parameters”, page 84 ff.

6.9 Administrator level

- All parameters can be edited (altered) in this level.
- In this level, you can also define which parameters can be edited (altered) by a “normal” user, and/or which calibration actions are permitted. Editable parameters can be edited in the operator level. Non-editable parameters are marked in the operator level by a key symbol .

You can access the administrator level as follows:

- * Press the  key for longer than 3 seconds.
 - * Use the  or  key to select ADMINISTRATOR LEVEL.
 - * Use  or  to enter the password 300.
 - * Press the  key.
-

6.9.1 Administrator levels

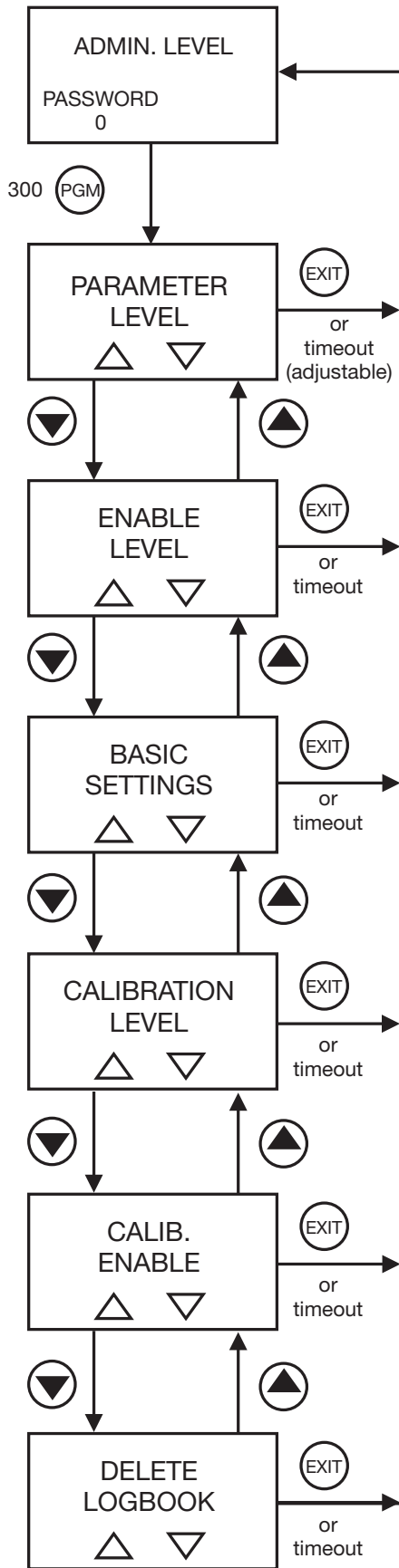

6 Operation

6.9.2 Parameter level

Here you can make the same settings as at the operator level. However, since the user has administrator rights in this case, parameters can also be altered that would be locked at the operator level.

For the list of adjustable parameters, see Chapter 6.8 “Operator level”, page 38ff.

6.9.3 Enable level

Here it is possible to enable (can be edited) or lock (cannot be edited) all the parameters.

The following section lists all the possible parameters. Some of these parameters may not be displayed on the instrument, depending on the configuration.

INPUT PH / ORP (pH, ORP, NH₃- concentration)

Zero point
Slope, acidic
Slope, alkaline
Monitoring of reference electrode
Maximum impedance of reference electrode
Monitoring of glass electrode
Filter time constant
Calibration interval

TEMPERATURE INPUT

Sensor type
Unit
Manual temperature
Filter time constant
Offset

BINARY INPUT

No function
Key inhibit
Hold operation
Alarm Stop

CONTR. CHAN. 1 or CONTR. CHAN. 2

Controller type
Setpoint
MIN/MAX contact
Proportional band
Reset time
Derivative time

Pulse period
 Minimum ON time
 Output level limit
 Maximum pulse frequency
 Hysteresis
 Pull-in delay
 Drop-out delay
 Controller alarm
 In Hold mode
 In event of error
 Max. process value
 Min. process value

CTRL.SPEC.FUNCT. (Special controller function)

I switch-off
 Separate controllers
 Manual mode

SWITCH OUTPUT 1 or SWITCH OUTPUT 2

Function
 Switching point
 Pre-alarm
 Spacing
 Hysteresis
 Switch-on delay
 Switch-off delay
 Pulse time
 During calibration
 Response to errors
 Response to Hold mode
 Response to manual mode
 Break (SPST-NC) / make (SPST-NO) contact

ANALOG OUTPUT 1 or ANALOG OUTPUT 2

Signal type
 Scaling start
 Scaling end
 During scaling
 In event of error
 In manual mode
 Safe value
 Simulation
 Simulation value
 Signal selector



Output	Analog process value output		Continuous controller Principal measurement variable
	Principal measurement variable	Temperature	
1	X	-	X
2	-	X	X

6 Operation

DISPLAY

Language
Lighting
LCD inverse
Meas. display type
Lower display
Upper display
Bar graph calibration start
Bar graph calibration end
MIN/MAX reset
Operator timeout
Contrast

6.9.4 Basic settings

The basic settings for the instrument are defined at this level. The parameters are altered by  and  keys. Use the  key to select the next parameter.

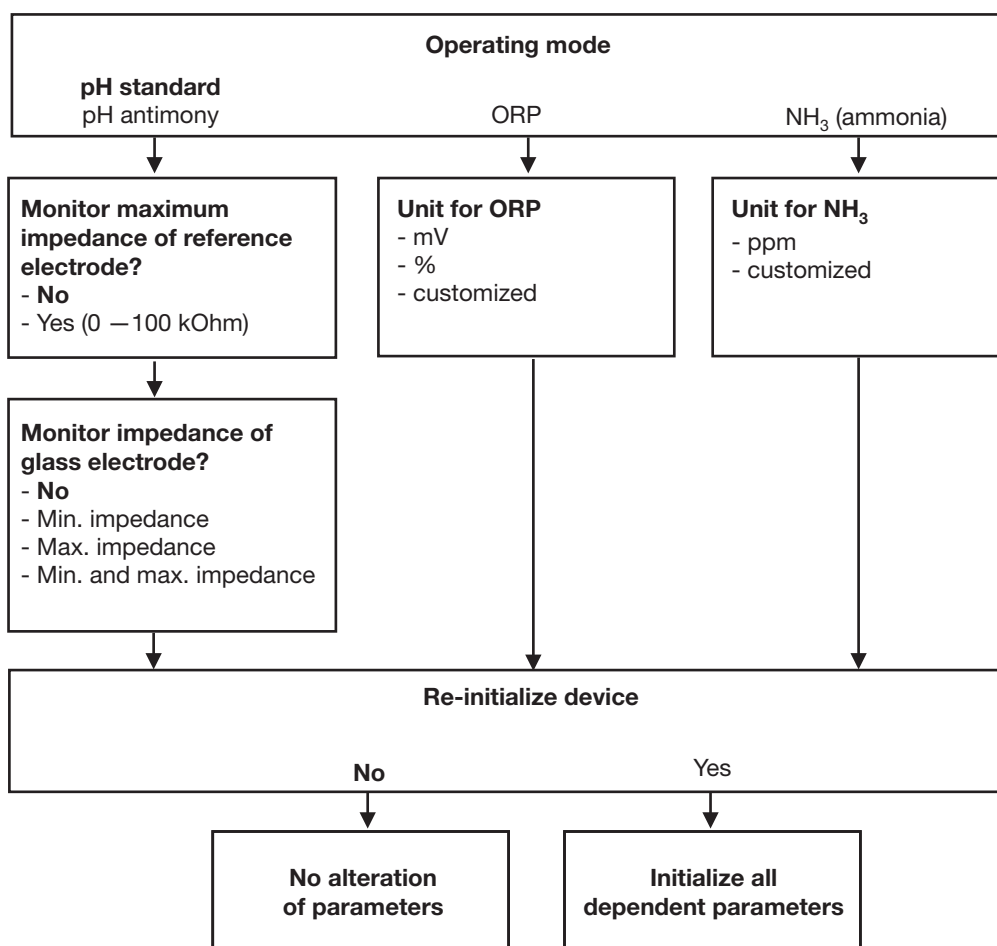

If you leave the "Basic settings" level with EXIT, all changes will be discarded and the previous settings will be restored.

6.9.5 Calibration level

1-POINT CALIB. (1-point calibration)

Only the cell zero point is shifted in this case.

Slope errors are not taken into account.

This method can only be recommended with reservation.

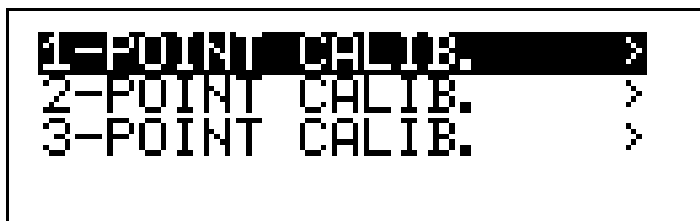

see Chapter 8 "Calibration", page 68ff.

2-POINT CALIB. (2-point calibration)

Two measurements are used here to determine the zero point and slope of the cell.

This method should be given preference.

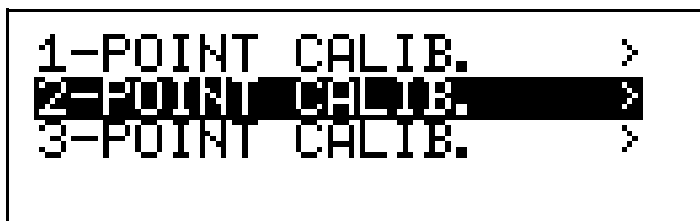

see Chapter 8 "Calibration", page 68ff.

3-POINT CALIB. (3-point calibration)

Three measurements are used here to determine the zero point and slope of the cell.

This method should be used when errors are to be expected due to high acidity or alkaline levels.



see Chapter 8 "Calibration", page 68ff.

6 Operation

6.9.6 Enable calibration

Here you can decide whether to enable the parameter for alteration (calibration) or not.

1-POINT CALIB.

2-POINT CALIB.

3-POINT CALIB.

6.9.7 Delete logbook

REALLY DELETE LOGBOOK?

YES / NO

6.10 Device info



The present configuration for all important parameters is shown here, e.g.

SENSOR -> PH STANDARD

MONIT. REF. -> OFF

MONIT. GLASS EL. -> OFF

6.11 Controller function

Simple switching functions

In the JUMO AQUIS 500, simple switching functions, such as alarm contacts and limit comparators or the signal from the calibration timer, are configured at the parameter level, through the parameters for "Switching output 1 or 2".









The parameters for the controller channel 1 or 2 respectively must then be set to "Off".

Higher-level control functions

Higher-level control functions are configured at the parameter level, through the parameters for "Controller channel 1 or 2".

The parameters for the controller channels must then be set to "Controller 1 or 2".

Operator level parameters

Switching output 1 / 2	Explanation
none	no switching function and no control function required
Controller 1	the instrument should have the higher-level control
Controller 2	the instrument should have the higher-level control
Controller alarm 1 / 2 Controller alarm  main variable  main variable  main variable  main variable  Temperature  Temperature  Temperature  Temperature Sensor fault Calibration timer	“simple” switching functions
Controller channel 1 / 2	
Limit value Pulse width Pulse frequency Continuous Modulating	“higher-level” control functions
Off	must be selected if “simple” switching functions are required

7 Commissioning

7.1 Fast start



This is a recommendation for configuring the instrument reliably in a short time.

If you check the setting options from this list before starting the configuration, you can avoid timeouts during configuration.

- * Mount the instrument, see Chapter 5 “Mounting”, page 22.
 - * Install the instrument, see Chapter 4 “Electrical connection”, page 12 ff.
 - * Call up the administrator level (ADMIN. LEVEL).
 - * Enter 300 as the password.
 - * Call up the parameter level (PARAMETER LEVEL).
 - * Set the menu item OP. TIMEOUT to 0 min. (no timeout).
 - * Leave the parameter level.
 - * Select basic settings, and work through the entire list of menu items.
 - * Answer the query “Re-initialize device” with YES.
 - * Configure the parameters, see Chapter 11 “Appendix”, page 84, e. g. input temperature, analog outputs, controller functions, etc.
 - * Calibrate the instrument for the sensor and sample medium.
-

7.2 Setup examples

7.2.1 Measurement of pH (standard sensor)

Range: 0 – 14 pH
 Output signal: 0 – 20 mA
 Temperature measurement: manual
 Controller function: off
 Sensor monitoring: off

Call up administrator level

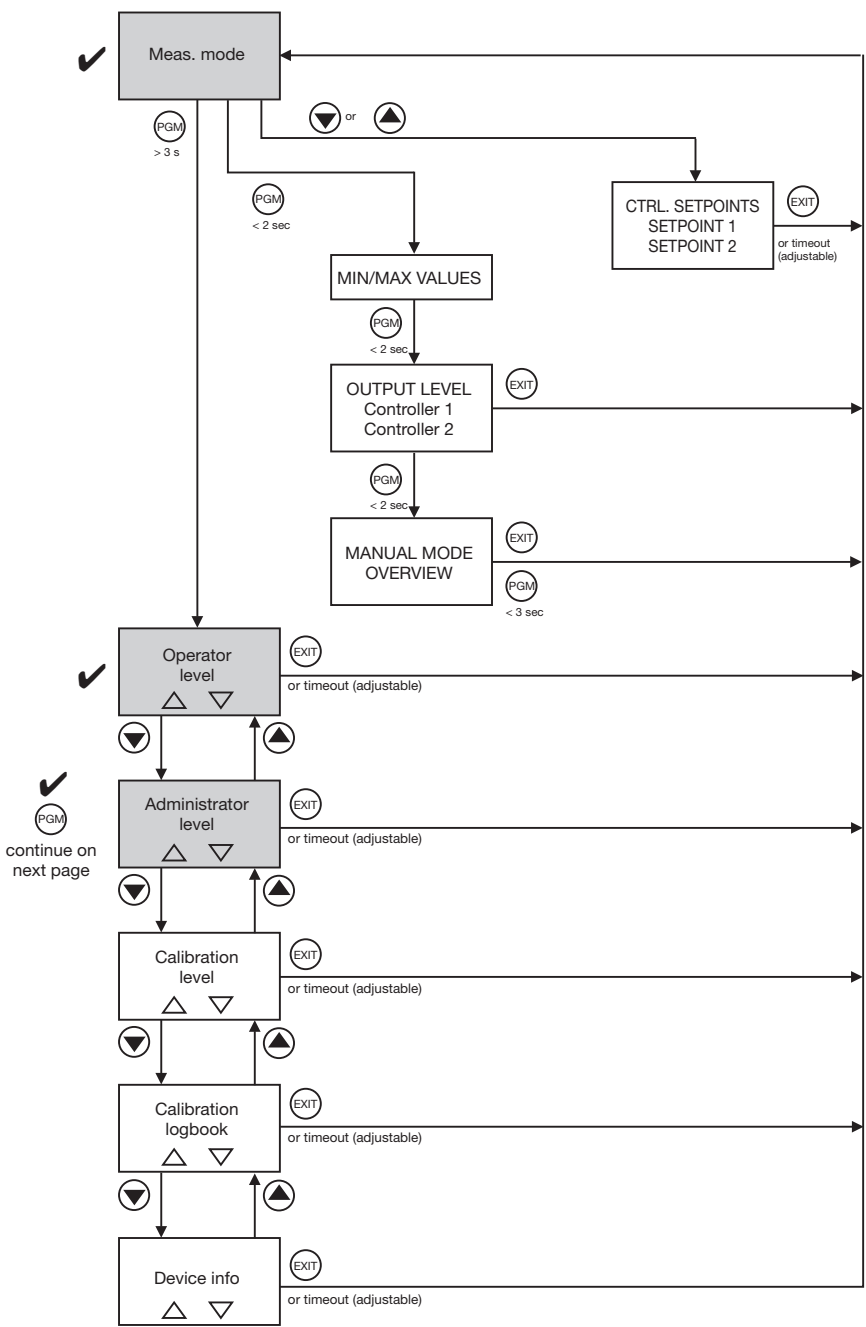

continue on next page

7 Commissioning

Call up basic settings

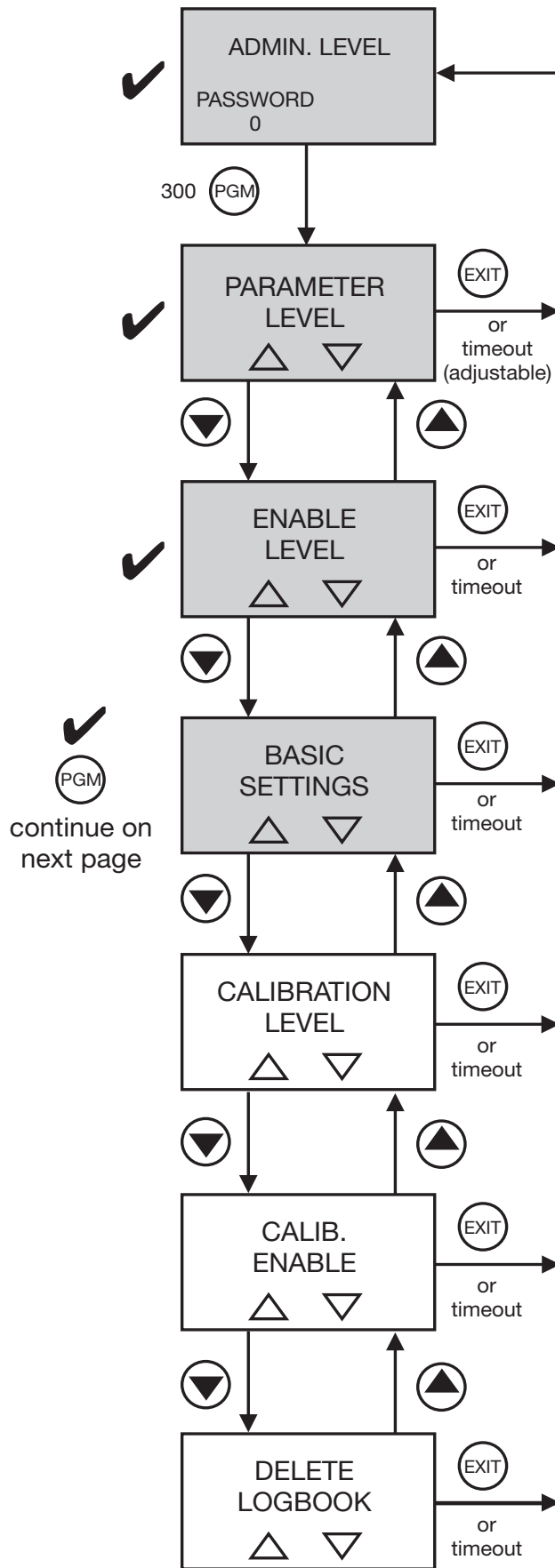

7 Commissioning

Basic settings for the main input: procedure

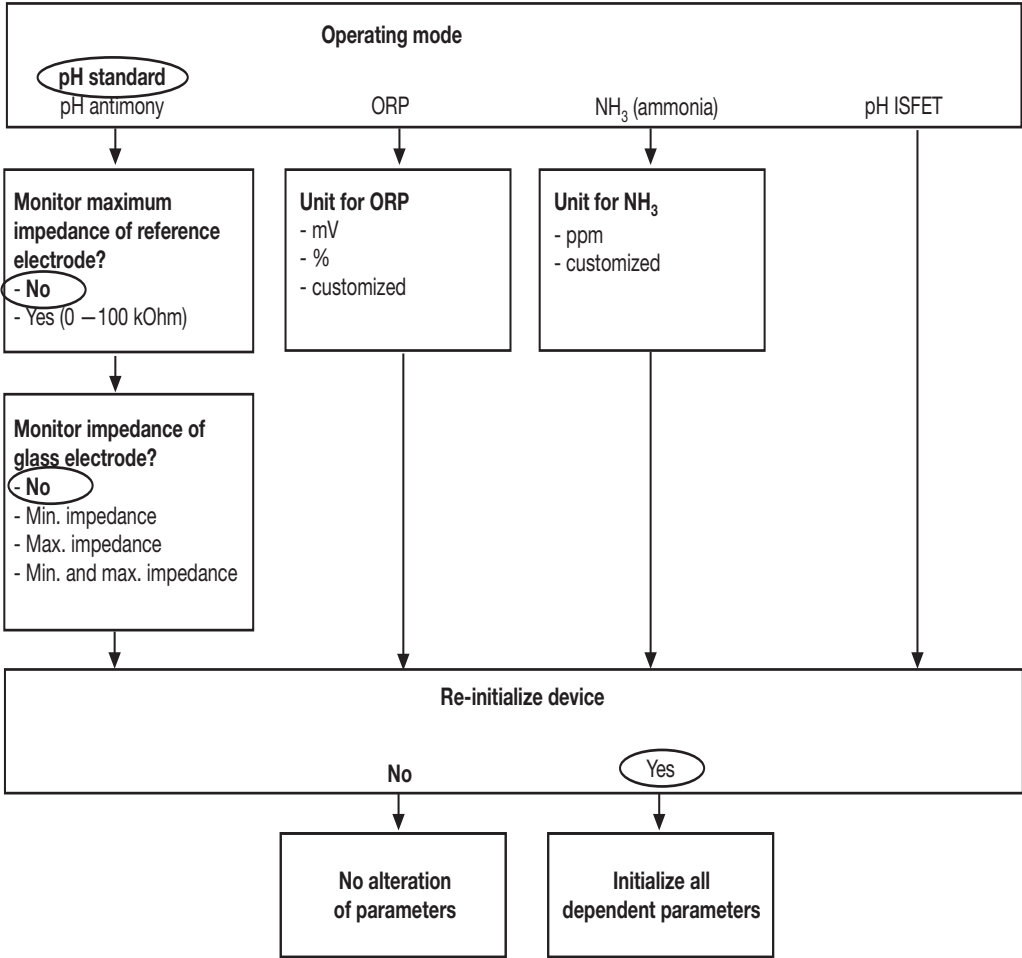

7 Commissioning

Concluding instrument settings

Input for temperature

Sensor type:	no sensor (manual)
Unit:	°C
Manual temperature:	25.0°C (present temperature of medium)
Filter time constant:	00:00:02

Analog output 1

Signal selector:	Main value
Signal type:	0 – 20 mA
Scaling start:	0.00 pH
Scaling end:	14.00 pH

7 Commissioning

7.2.2 Measurement of pH (standard sensor)

Range:	2 – 12 pH
Output signal:	4 – 20 mA
Temperature measurement	by Pt100
Controller function:	pulse width controller
Setpoint 1:	pH 6.5
Setpoint 2:	pH 8.5
Sensor monitoring:	off

Call up administrator level

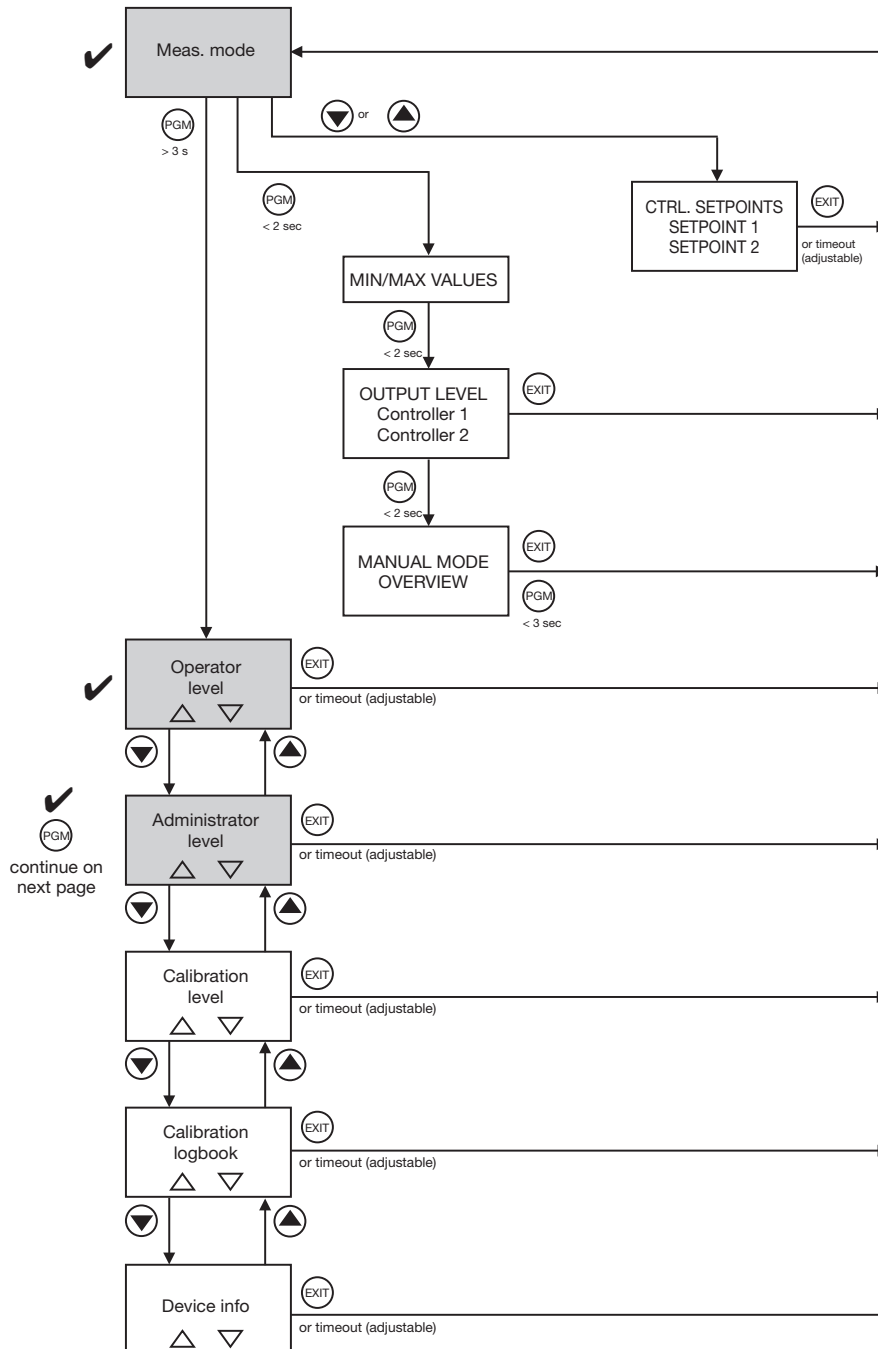

continue on next page

Call up basic settings

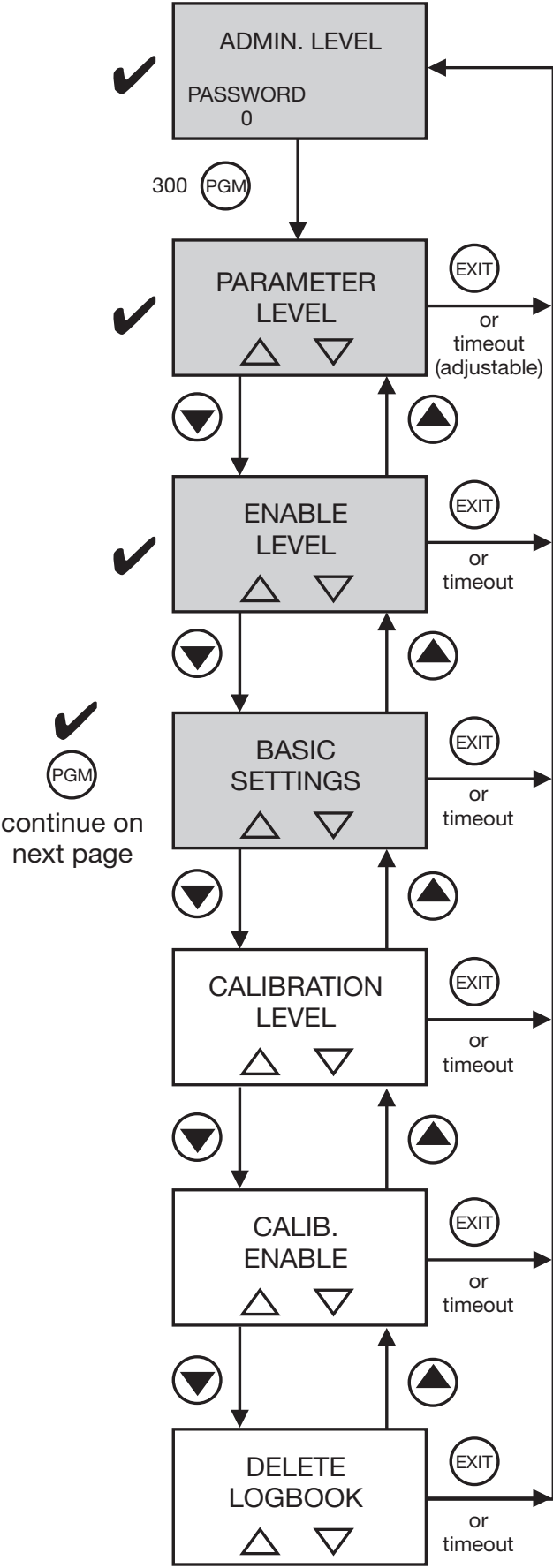

7 Commissioning

Basic settings for the main input: procedure

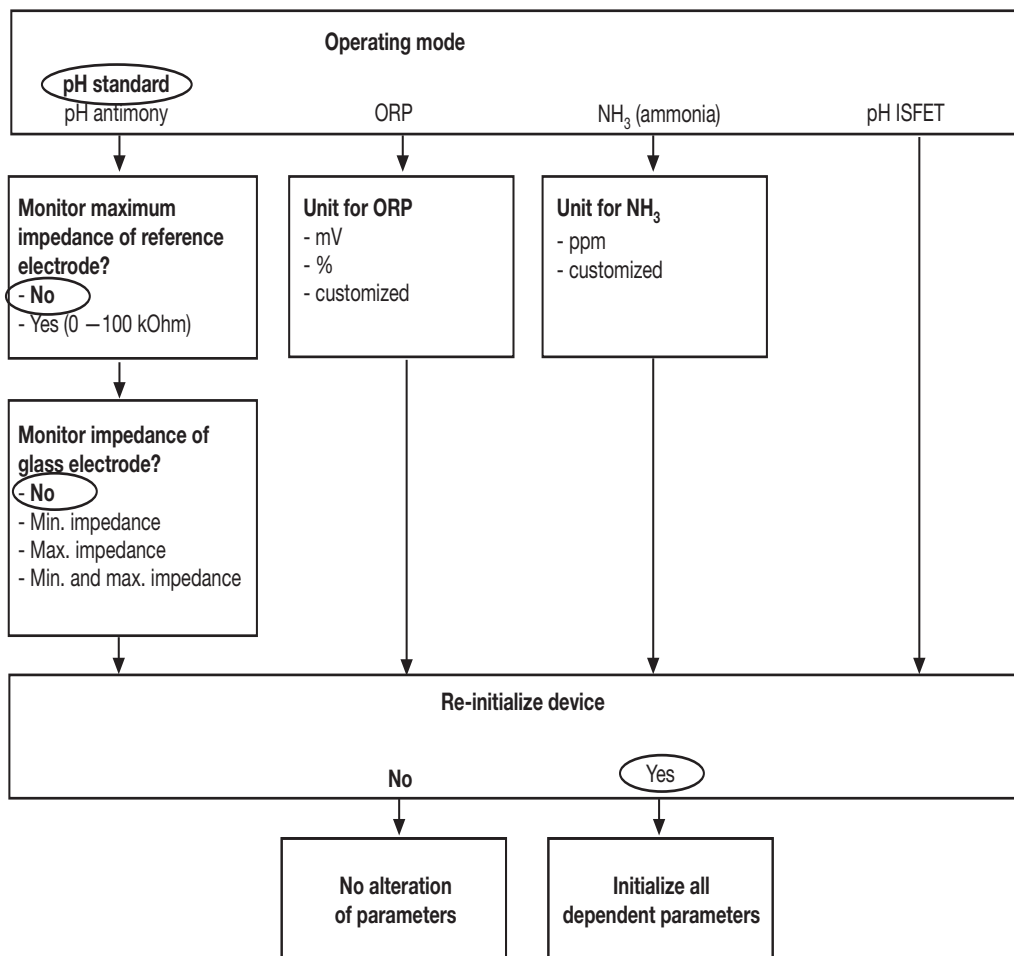

Call up
parameter
level

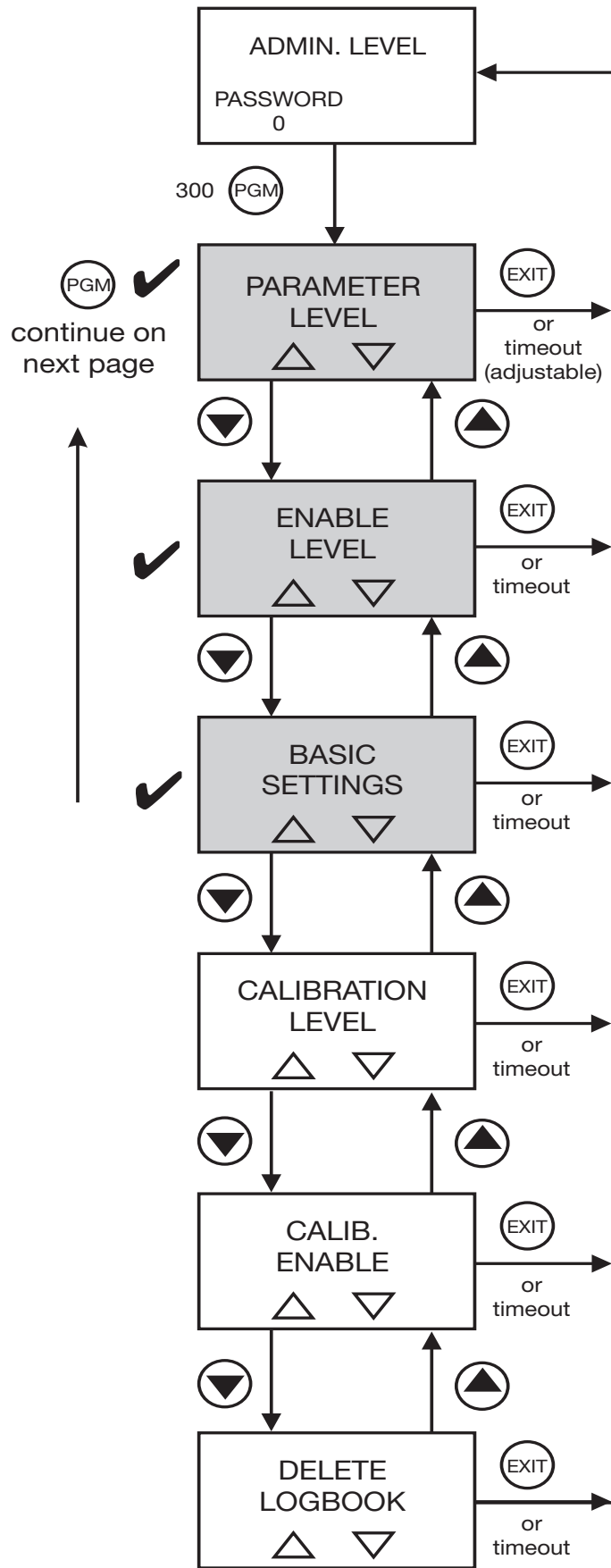

7 Commissioning

Concluding instrument settings

Input for temperature

Sensor type:	Pt100/Pt1000
Unit:	°C
Filter time constant:	00:00:02
Offset:	0.0°C

Controller channel 1

Controller type:	pulse width output
Setpoint:	6.5 pH
MIN / MAX contact:	MIN contact
Proportional band:	as required
Reset time:	as required
Derivative time:	as required
Pulse period:	as required
Switch-on time:	as required
Output level limit:	as required
Controller alarm:	as required
Alarm tolerance:	as required
Alarm delay:	as required
In Hold mode:	as required
“Hold” output level:	as required
In event of error:	as required
MAX setpoint:	as required
MIN setpoint:	as required
Alarm delay:	as required

Controller channel 2

Controller type:	pulse width output
Setpoint:	8.5 pH
MIN /MAX contact:	MIN contact
Proportional band:	as required
Reset time:	as required
Derivative time:	as required
Pulse period:	as required
Switch-on time:	as required
Output level limit:	as required
Controller alarm:	as required
Alarm tolerance:	as required
Alarm delay:	as required
In Hold mode:	as required
“Hold” output level:	as required
In event of error:	as required

7 Commissioning

MAX setpoint:	as required
MIN setpoint:	as required
Alarm delay:	as required

Switching output 1

Function:	CONTROLLER 1
-----------	--------------

Switching output 2

Function:	CONTROLLER 2
-----------	--------------

Analog output 1

Signal selector:	Main value
Signal type:	4 – 20 mA
Scaling start:	2 pH
Scaling end:	12 pH
During calibration:	as required
In event of error:	as required
In Hold mode:	as required
Safe value:	as required
Simulation:	as required
Simulation value:	as required

7 Commissioning

7.2.3 ORP measurement

Range: 0 – 1000 mV
 Output signal: 0 – 10 V
 Controller function: limit controller
 Limit: 600 mV

Call up administrator level

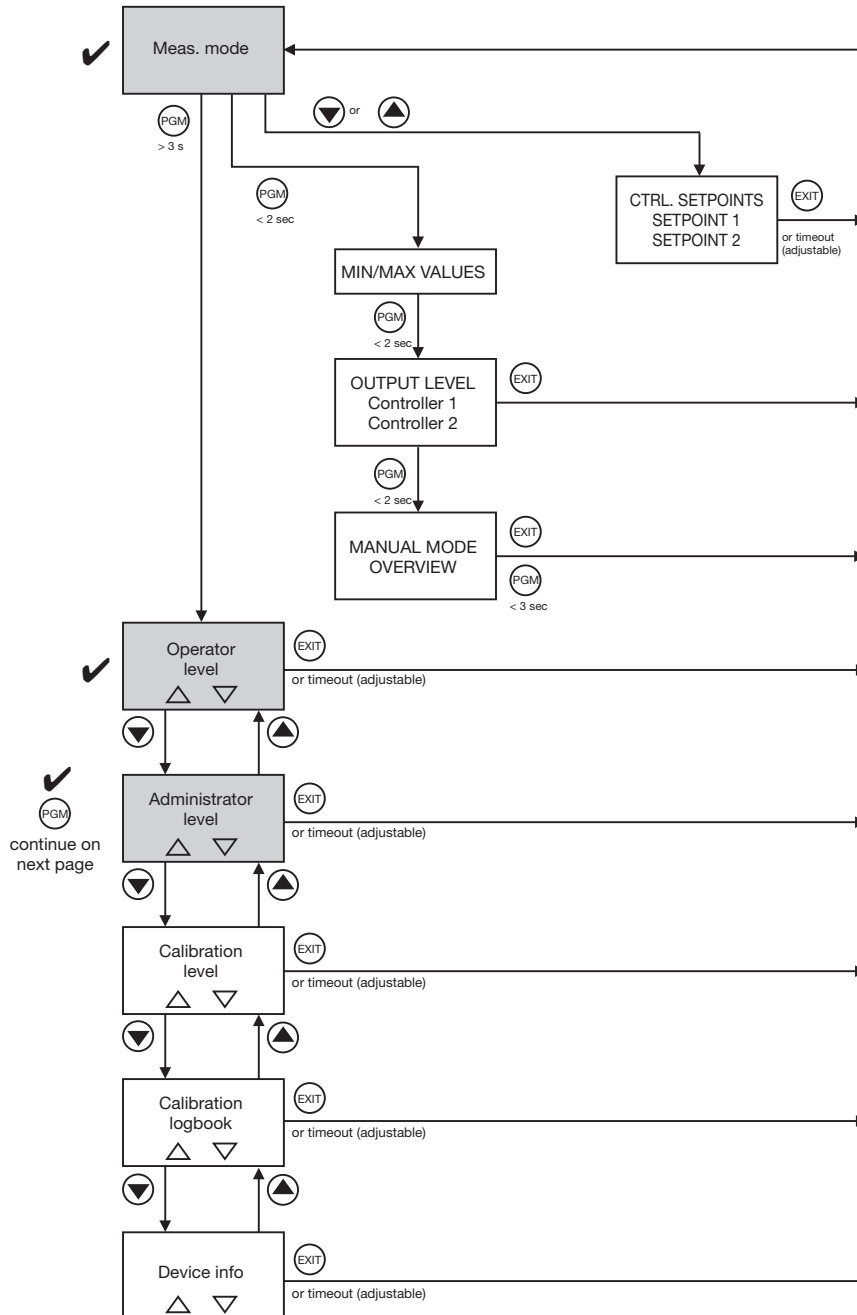

Call up basic settings

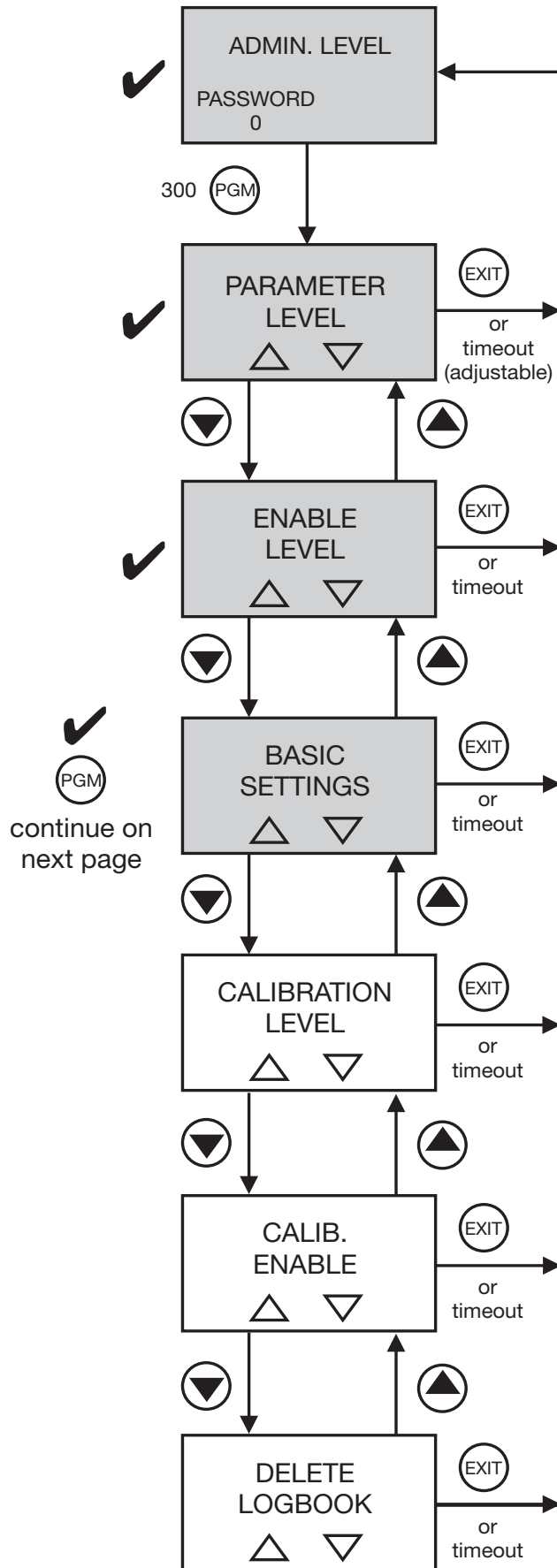

7 Commissioning

Basic settings for the main input: procedure

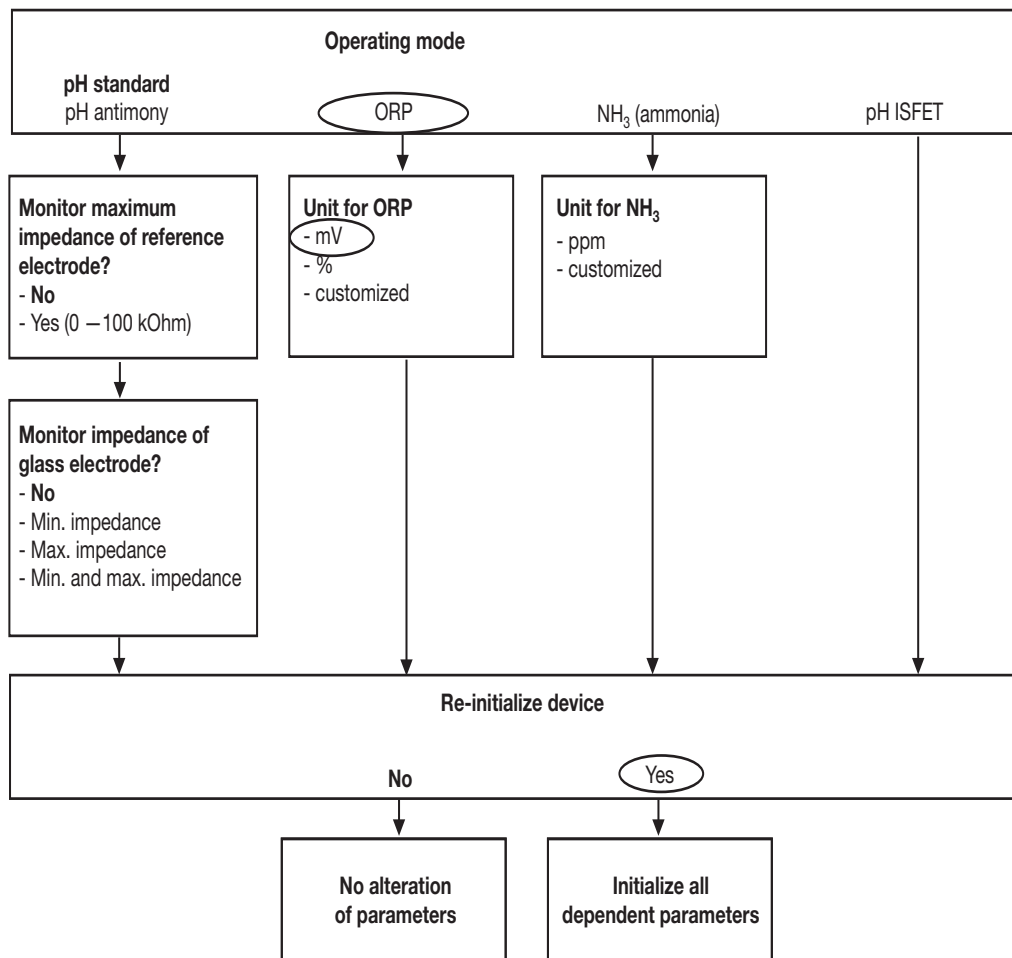

Call up
parameter
level

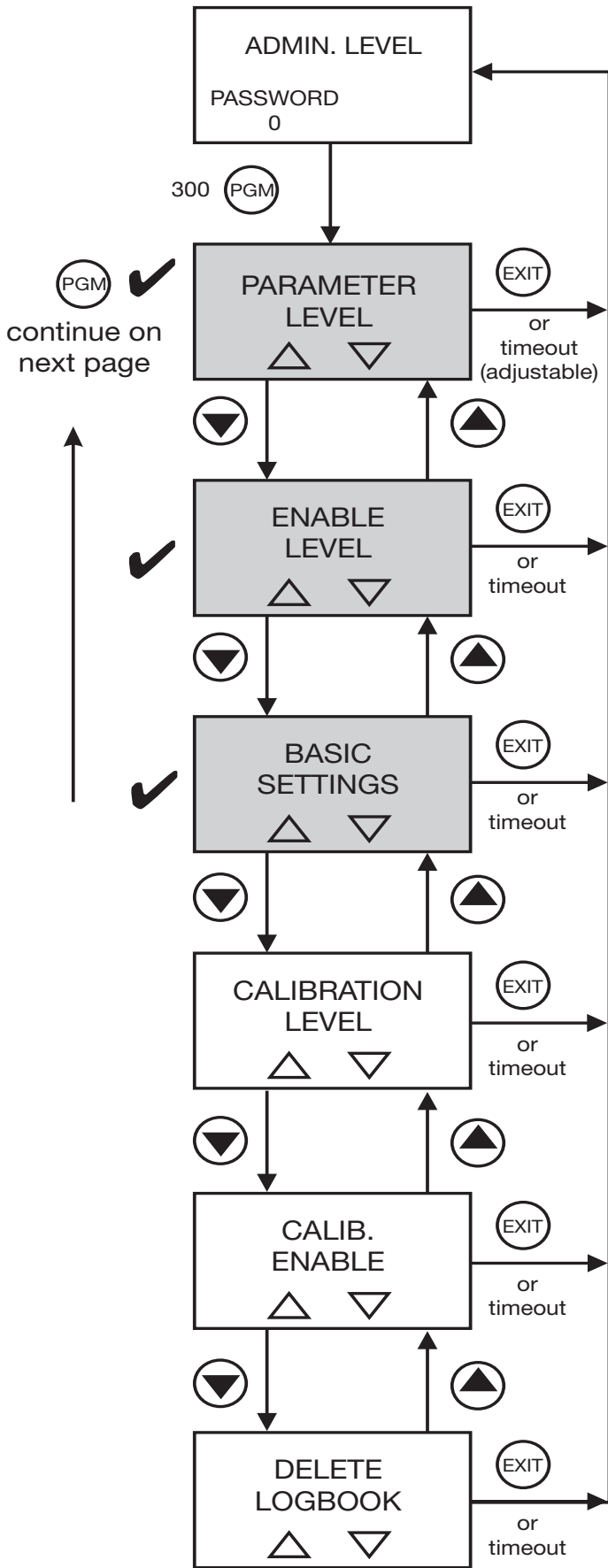

7 Commissioning

Concluding instrument settings

Controller channel 1

Control type:	limit
Setpoint:	600 mV
MIN / MAX contact:	as required
Hysteresis:	as required
Pull-in delay:	as required
Drop-out delay:	as required
Controller alarm:	as required
In Hold mode:	as required
In event of error:	as required
MAX setpoint:	as required
MIN. setpoint:	as required

Controller channel 2

Control type:	off
---------------	-----

Switching output 1

Function:	controller 1
-----------	--------------

Switching output 2

Function:	no function
-----------	-------------

Analog output 1

Signal selector:	Main value
Signal type:	0 – 10 V
Scaling start:	0 mV
Scaling end:	1000 mV

7 Commissioning

7.2.4 Measurement of NH₃- (ammonia) concentration

Range:	0 – 100 ppm
Output signal:	0 – 20 mA
Controller function:	limit controller
Limit:	10 ppm

Call up administrator level

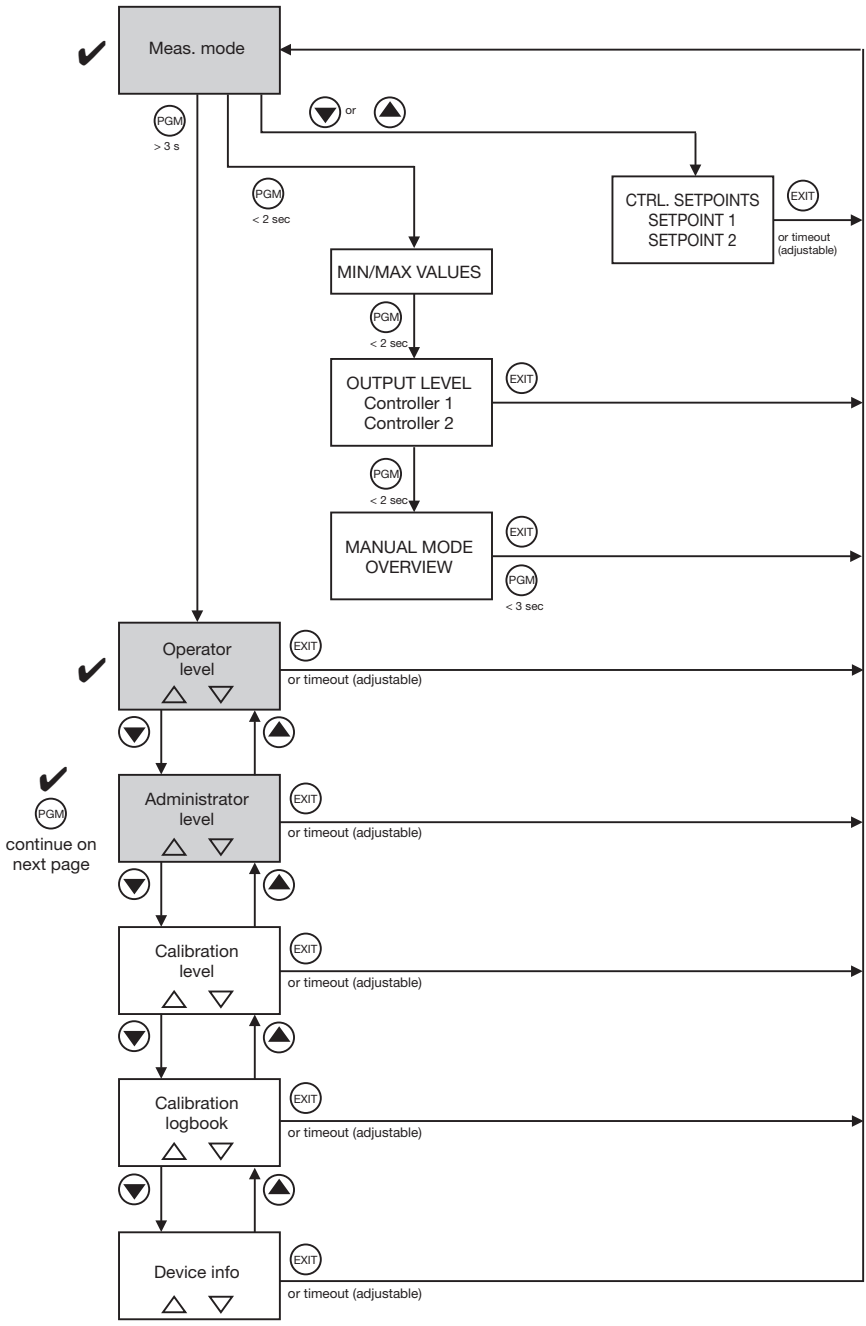

continue on next page

7 Commissioning

Call up basic settings

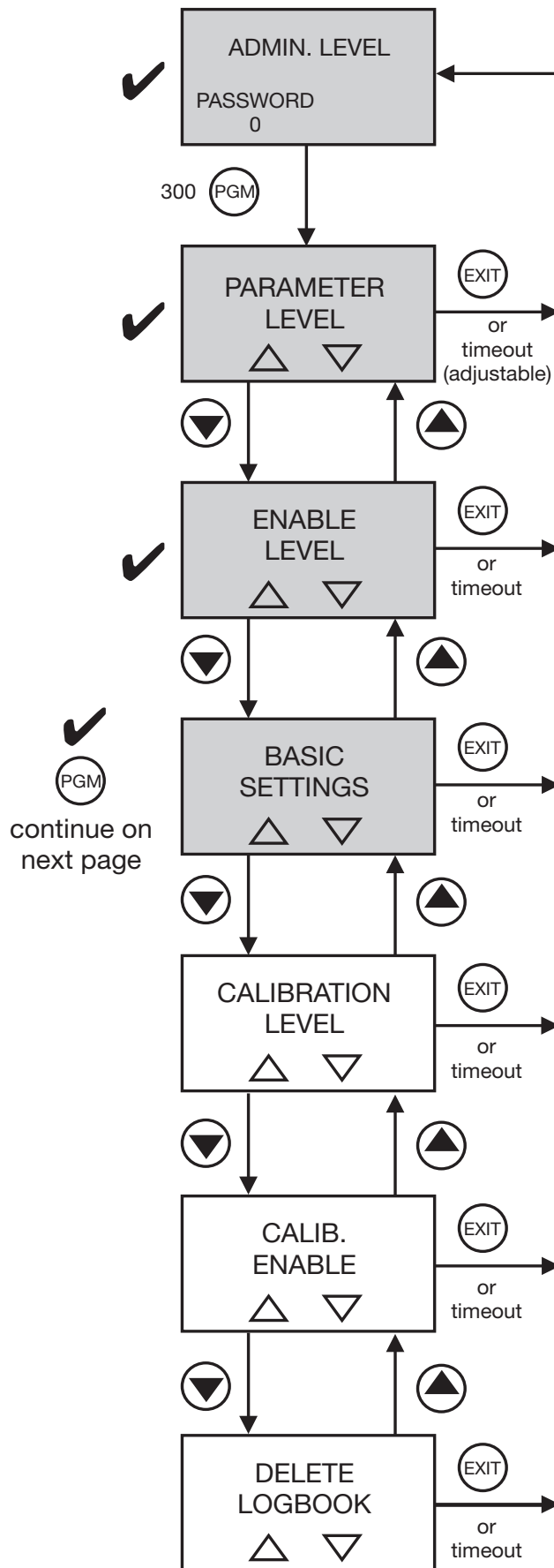

7 Commissioning

Basic settings for the main input: procedure

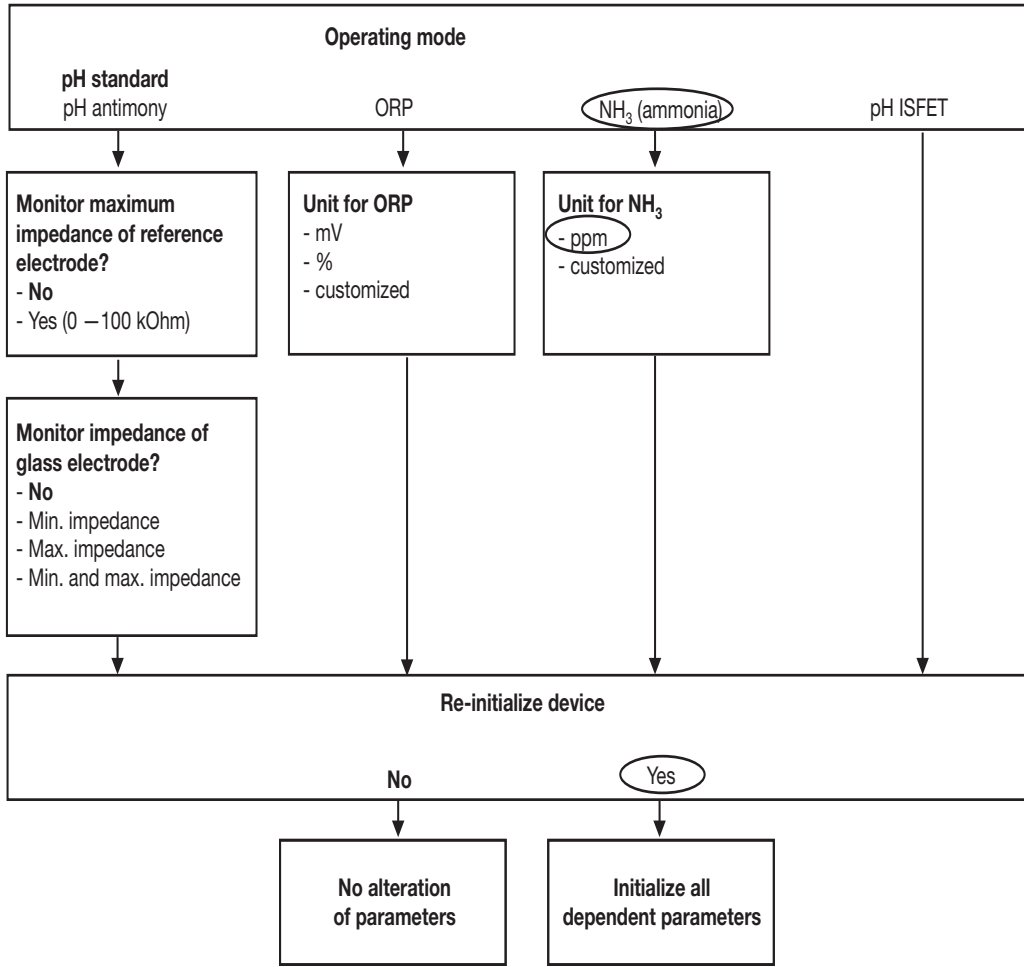

7 Commissioning

Call up
parameter
level

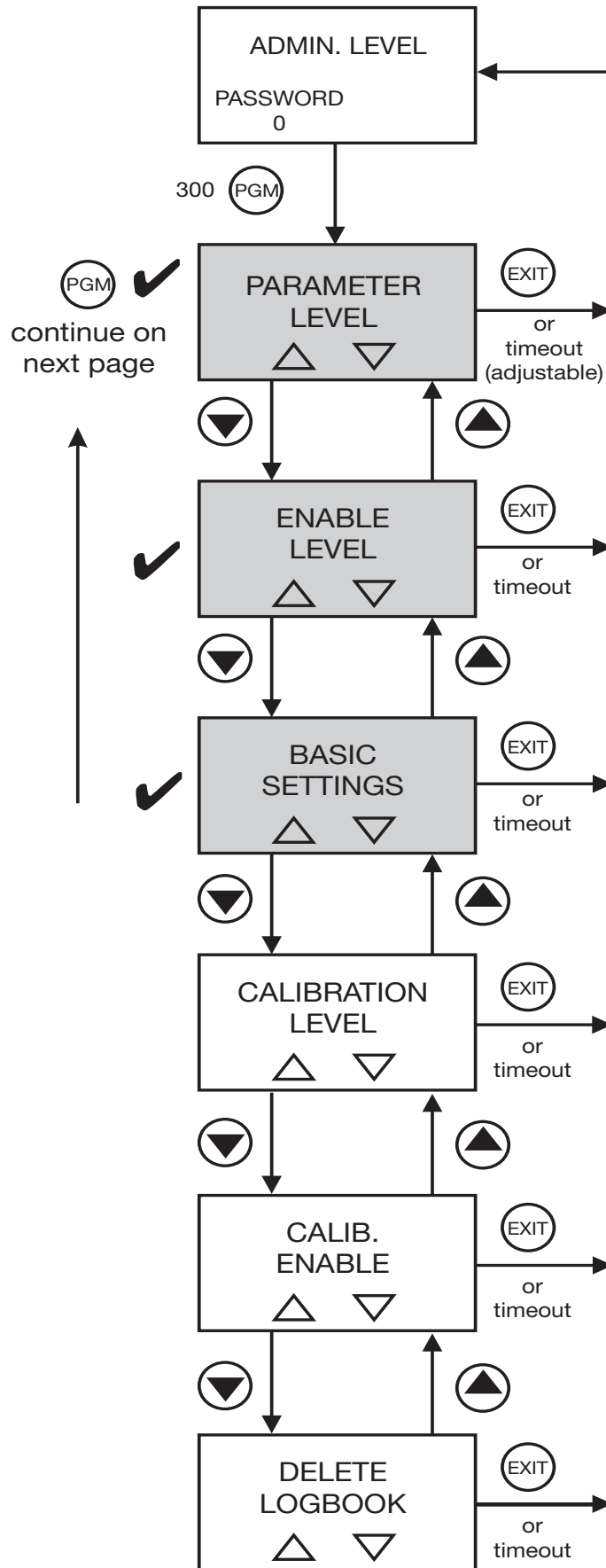

7 Commissioning

Concluding instrument settings

Controller channel 1	Control type:	limit
	Setpoint:	10 ppm
	MIN / MAX contact:	as required
	Hysteresis:	as required
	Pull-in delay:	as required
	Drop-out delay:	as required
	Controller alarm:	as required
	In Hold mode:	as required
	In event of error:	as required
	MAX setpoint:	as required
MIN setpoint:	as required	
<hr/>		
Controller channel 2	Control type:	off
<hr/>		
Switching output 1	Function:	controller 1
<hr/>		
Switching output 2	Function:	no function
<hr/>		
Analog output 1	Signal selector:	Main value
	Signal type:	0 – 20 mA
	Scaling start:	0 ppm
	Scaling end:	100 ppm

8 Calibration

8.1 pH electrode

General Various calibration options are available to adapt the instrument to the pH electrode.

- 1-point calibration
This is only recommended for special applications, e.g. high-purity water.
- 2-point calibration
This is recommended as the standard method.
- 3-point calibration
This is only recommended for special applications with increased accuracy requirements, both within the acidic and alkaline ranges.

When to calibrate The pH combination electrode (or glass and reference electrode) should be cleaned at regular intervals (depending on the sample medium) and the transmitter calibrated.

Calibration start Calibrating can be started as follows:

- by pressing the  key, if this has been enabled in ADMIN. LEVEL / PASSWORD / CALIB. ENABLE.
- via ADMIN. LEVEL / PASSWORD / CALIB. LEVEL.
- via CALIB. LEVEL if this has been enabled in ADMIN. LEVEL / PASSWORD / CALIB. ENABLE.



The display blinks during calibration.
The analog outputs will respond as configured in OPERATOR LEVEL / ANALOG OUTPUT x / DURING CALIBRATION.
The relays will respond in accordance with the configuration of the switching outputs.

8.1.1 1-point calibration

Requirements

- The supply voltage for the instrument must be present. see Chapter 4 "Electrical connection", page 12ff.
- A combination electrode must be connected to the transmitter.
- "PH STANDARD" must be configured as the sensor in the basic settings.
- Calibration must be enabled, see Chapter 6.9.1 "Administrator levels", page 39.
- The transmitter is in the measurement mode.

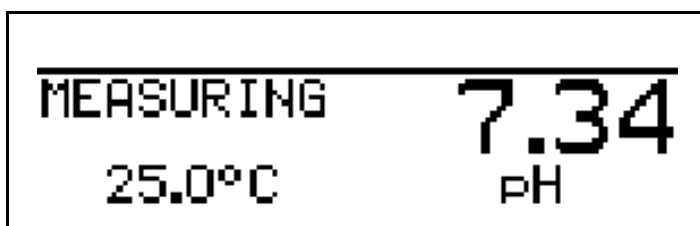

8 Calibration

- * Immerse the combination electrode in a buffer solution with a known pH.



The temperature of the buffer solution must remain constant during calibration!

- * Start the calibration (by pressing the **CAL** key, or via the Administrator level).

```
1-POINT CALIB. >
2-POINT CALIB. >
3-POINT CALIB. >
```

- * Using the **PGM** key, start 1-point calibration.

```
                CALIB
-----
ENTRY          25.0 °C
TEMP.
```

- * With manual temperature input, set the temperature of the calibration solution using the **▼** or **▲** key and confirm the selection with **PGM**.

```
                CALIB
-----
MEAS.          7.43
REFERENCE      PH
```



- * Wait until the displayed value is stable; then continue with **PGM**.

```
                CALIB
-----
ENTRY          7.00
REFERENCE      PH
```

- * Set the displayed value to the value of the buffer solution using the **▼** or **▲** key; then continue with **PGM**.

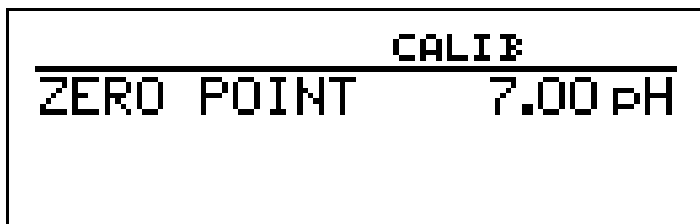
8 Calibration



- * Accept the zero point with the  key or use the  key to reject the value.

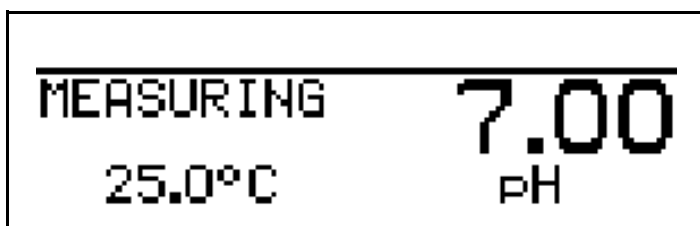

The instrument returns to the measurement mode.

8.1.2 2-point calibration



The buffer solutions (reference solutions) used for calibration must differ by at least 2 pH.

During calibration, the temperature of the two buffer solutions must be the same and must remain constant.

Requirements

- The supply voltage for the instrument must be present. see Chapter 4 "Electrical connection", page 12ff.
- A combination electrode must be connected to the transmitter.
- "PH STANDARD" must be configured as the sensor in the basic settings.
- Calibration must be enabled, see Chapter 6.9.1 "Administrator levels", page 39.
- The transmitter is in the measurement mode.

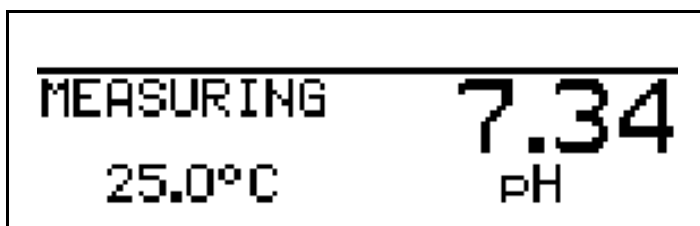

- * Immerse the combination electrode in the first buffer solution with a known pH (e.g. 4.00).

8 Calibration

- * Start the calibration (by pressing the **CAL** key, or via the Administrator level).

```
1-POINT CALIB. >
2-POINT CALIB. >
3-POINT CALIB. >
```

- * Using the **PGM** key, start 2-point calibration.

```
                CALIB
-----
ENTRY          25.0 °C
TEMP.
```

- * With manual temperature input, set the temperature of the buffer solution using the **▼** or **▲** key and confirm the selection with **PGM**.

```
                CALIB
-----
MEAS.          4.34
REF. 1         pH
```

- * Wait until the displayed value is stable; then continue with **PGM**.

```
                CALIB
-----
ENTRY          4.00
REF. 1         pH
```

- * Set the displayed value to the value of the first buffer solution (e.g. 4.00) using the **▼** or **▲** key; then continue with **PGM**.

```
                CALIB
-----
MEAS.          8.01
REF. 2         pH
```



- * Rinse, then dry the pH combination electrode.
- * Immerse the pH combination electrode in the second buffer solution (e.g. 8.00).

8 Calibration

- * Wait until the displayed value is stable; then continue with .





The screen displays the word "CALIB" at the top. Below it, a horizontal line separates the header from the data. The data shows "ENTRY REF. 2" on the left and "8.00 pH" on the right.

- * Set the displayed value to the value of the second buffer solution (e.g. 8.00) using the  or  key; then continue with .



The screen displays the word "CALIB" at the top. Below it, a horizontal line separates the header from the data. The data shows "ZERO POINT" and "SLOPE" on the left, and "7.00 pH" and "101.1%" on the right.

The zero and slope determined by the instrument are displayed.

- * Accept the calibrated values with the  key or use the  key to reject the value.

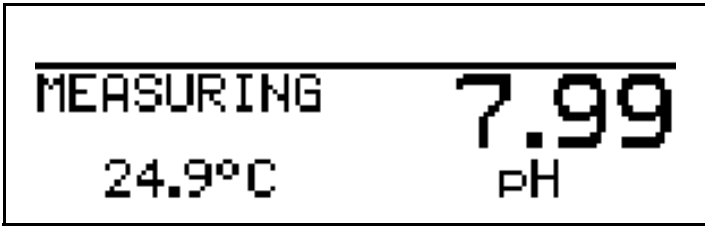

The screen displays the word "MEASURING" at the top. Below it, a horizontal line separates the header from the data. The data shows "24.9°C" on the left and "7.99 pH" on the right.

The instrument returns to the measurement mode.

8.1.3 3-point calibration



The buffer solutions (reference solutions) used for calibration must have the following values:

Buffer solution 1: within the neutral range (7 pH as accurately as possible)

Buffer solution 2: larger than 9 pH

Buffer solution 3: smaller than 5 pH

The temperature of the buffer solutions must be the same and must remain constant during calibration.

The buffer solutions can be used in any order during calibration.

Requirements

- The supply voltage for the instrument must be present. see Chapter 4 "Electrical connection", page 12ff.
 - A combination electrode must be connected to the transmitter.
 - "PH STANDARD" must be configured as the sensor in the basic settings.
-

8 Calibration

- Calibration must be enabled, see Chapter 6.9.1 “Administrator levels”, page 39.
- The transmitter is in the measurement mode.

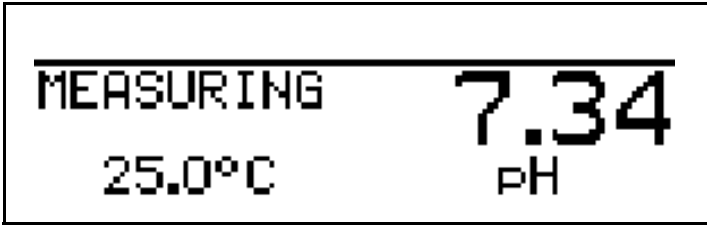

MEASURING 7.34
25.0°C pH

- * Immerse the combination electrode in the first buffer solution with a known pH value.



The temperature of the three buffer solutions must be the same and must remain constant during calibration.

- * Start the calibration (by pressing the  key, or via the Administrator level).





1-POINT CALIB. >
2-POINT CALIB. >
3-POINT CALIB. >

- * Using the  key, start 3-point calibration.



CALIB
ENTRY 25.0°C
TEMP.

With manual temperature input, set the temperature of the calibration solution using the  or  key and confirm the selection with .





CALIB
MEAS. 3.00
REF. 1 pH

8 Calibration

- * Wait until the displayed value is stable; then continue with .

CALIB	
ENTRY	3.50
REF. 1	pH

- * Set the displayed value to the value of the first buffer solution using the  or  key; then continue with .



CALIB	
MEAS.	3.00
REF. 2	pH

- * Rinse, then dry the combination electrode.
- * Immerse the combination electrode in the second buffer solution with a known pH value.

CALIB	
MEAS.	7.00
REF. 2	pH

- * Wait until the displayed value is stable; then continue with .

CALIB	
ENTRY	7.70
REF. 2	pH

- * Set the displayed value to the value of the second buffer solution using the  or  key; then continue with .

CALIB	
MEAS.	7.00
REF. 3	pH



- * Rinse, then dry the combination electrode.
- * Immerse the combination electrode in the third buffer solution with a known pH.

8 Calibration

CALIB	
MEAS.	11.00
REF. 3	pH



- * Wait until the displayed value is stable; then continue with .

CALIB	
ENTRY	10.70
REF. 3	pH

- * Set the displayed value to the value of the second buffer solution using the  or  key; then continue with .

CALIB	
ZERO POINT	7.70 pH
SLOPE ACID	96.3%
SLOPE ALK.	ERROR

The zero point of the combination electrode, as well as its slope in the acidic/alkaline range of the characteristic are shown.

- * Accept the calibrated values with the  key or use the  key to reject the value.

MEASURING	7.99
24.9°C	pH

The instrument returns to the measurement mode.

8 Calibration

8.2 pH antimony electrode

Antimony electrodes are calibrated in the same way as normal pH ones.

- General notes on calibration, see “General”, page 68.
 - 1-point calibration, see Chapter 8.1.1 “1-point calibration”, page 68.
 - 2-point calibration, see Chapter 8.1.2 “2-point calibration”, page 70.
 - 3-point calibration, see Chapter 8.1.3 “3-point calibration”, page 72.
-

8.3 ORP electrode

General

Two calibration options are available to adapt the instrument to the ORP electrode.

- 1-point calibration
With configuration “mV” for the UNIT.
 - 2-point calibration
With configuration “%” or “CUSTOMIZED” for the UNIT.
-

When to calibrate

The ORP combination electrode (or metal and reference electrode) should be cleaned at regular intervals (depending on the sample medium) and the transmitter calibrated.

Calibration start

Calibrating can be started as follows:

- by pressing the  key,
if this has been enabled in ADMIN. LEVEL / PASSWORD / CALIB. ENABLE.
 - via ADMIN. LEVEL / PASSWORD / CALIB. LEVEL
 - via CALIB. LEVEL
if this has been enabled in ADMIN. LEVEL / PASSWORD / CALIB. ENABLE.
-



The display blinks during calibration.

The analog outputs will respond as configured in OPERATOR LEVEL / ANALOG OUTPUT x / DURING CALIBRATION.

The relays will respond in accordance with the configuration of the analog outputs and switching outputs.

8.3.1 1-point calibration

Requirements

- The supply voltage for the instrument must be present.
see Chapter 4 “Electrical connection”, page 12ff.
 - A combination electrode must be connected to the transmitter.
 - “REDOX” (ORP) must be configured for the sensor and “mV” for the UNIT.
-

8 Calibration

- Calibration must be enabled, see Chapter 6.9.1 “Administrator levels”, page 39.
- The transmitter is in the measurement mode.



- * Immerse the combination electrode in a buffer solution with a known ORP.





The ORP of the sample solution is **not** dependent on temperature!

- * Start the calibration (by pressing the  key, or via the Administrator level).



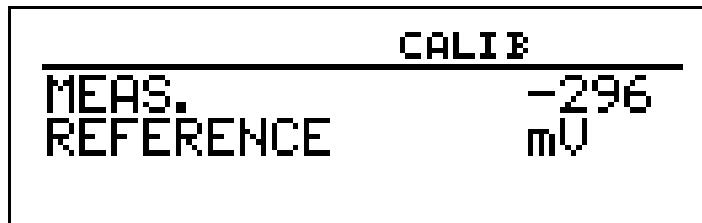

- * Using the  key, start 1-point calibration.



Wait until the displayed value is stable; then continue with .



- * Set the displayed value to the value of the buffer solution using the  or  key; then continue with .

8 Calibration

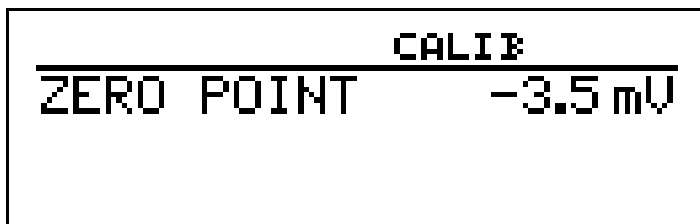

The zero point that was determined by the instrument is shown.

- * Accept the value with the (PGM) key or use the (EXIT) key to reject the value.

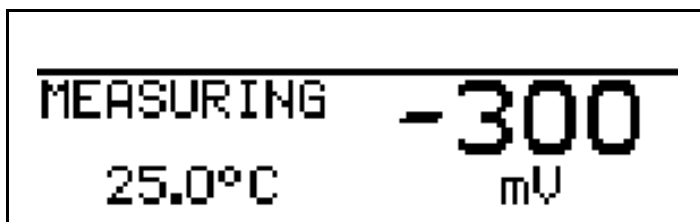

The instrument returns to the measurement mode.

8.3.2 2-point calibration

Requirements

- The supply voltage for the instrument must be present. see Chapter 4 “Electrical connection”, page 12ff.
- A combination electrode must be connected to the transmitter.
- “REDOX” (ORP) must be configured for the sensor and “CUSTOMIZED” or “%” for the UNIT in the basic settings.
- Calibration must be enabled, see Chapter 6.9.1 “Administrator levels”, page 39.
- The transmitter is in the measurement mode.

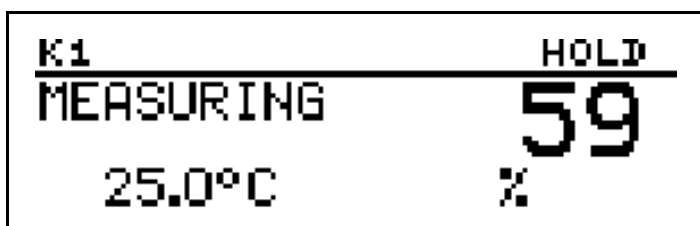

- * Immerse the combination electrode in a buffer solution with a known ORP.



The ORP of the sample solution is **not** dependent on temperature!

- * Start the calibration (by pressing the (CAL) key, or via the Administrator level).

8 Calibration



```
2-POINT CALIB. >
```

- * Using the  key, start 1-point calibration.

```
K1          CALIB HOLD
-----
MEAS.                59
REF. 1              mV
```

- * Wait until the displayed value is stable; then continue with .



```
K1          CALIB HOLD
-----
ENTRY                25.0
REF. 1              %
```

- * Set the displayed value to the value of the first buffer solution using the  or  key; then continue with .

```
K1          ALARM HOLD
-----
MEAS.                -60
REF. 2              mV
```

- * Rinse, then dry the ORP combination electrode.
- * Immerse the ORP combination electrode in the second buffer solution.
- * Wait until the displayed value is stable; then continue with .

```
K1          ALARM HOLD
-----
ENTRY                80.0
REF. 2              %
```

- * Set the displayed value to the value of the second buffer solution using the  or  key; then continue with .

8 Calibration

K1	ALARM HOLD
ZERO POINT	113 %
SLOPE	-216 %

The zero and slope determined by the instrument are displayed.

- * Accept the calibrated values with the **PGM** key or use the **EXIT** key to reject the value.

K1	HOLD
MEASURING	80
25.0°C	%

The instrument returns to the measurement mode.

8.4 Ammonia (NH₃)- cell

8.4.1 General information

From exemplar to exemplar the electrical features of all sensors are a little different; in addition to that they change during operation (e.g. due to precipitation or abrasion) which causes a change of the sensor's output signal. For measurement of ammonia with "normal" accuracy requirements, the transmitter uses a typical characteristic - dependent on the concentration. With the zero shift the individual features of the sensor are considered; this reduces the calibration procedure considerably. The software of the transmitter is especially adjusted to the cooling media control.

Time of Calibration ?

- in regular time intervals - dependent on measuring medium and demands
 - if the upper display shows negative values
 - if the upper display shows "Underrange/Overrange"
-

8.4.2 1-point calibration

Requirements

- The supply voltage for the instrument must be present. see Chapter 4 "Electrical connection", page 12ff.
 - A combination electrode must be connected to the transmitter.
 - Calibration must be enabled, see Chapter 6.9.1 "Administrator levels", page 39.
 - "AMMONIA NH₃" must be configured for the sensor in the basic settings.
-

8 Calibration

- The transmitter is in the measurement mode.

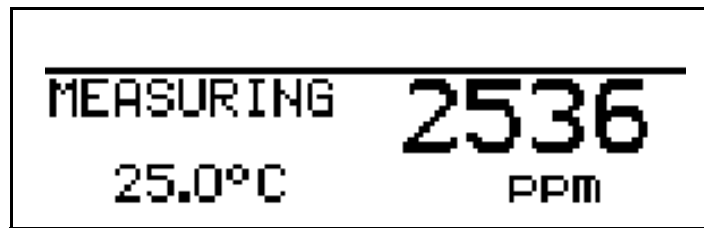

MEASURING 25.0°C 2536 PPM

- * Immerse the combination electrode in a solution **without ammonia**.
- * Start the calibration (by pressing the **CAL** key, or via the Administrator level).



1-POINT CALIB.

- * Using the **PGM** key, start 1-point calibration.

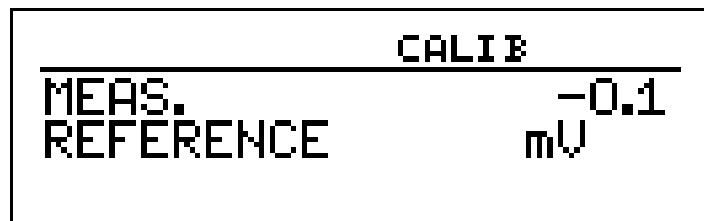

CALIB
MEAS. REFERENCE -0.1 mV

- * Wait until the displayed value is stable; then continue with **PGM**.



CALIB
ZERO POINT -0.1 mV

- * Use the **PGM** key to confirm the calibration result, or use the **EXIT** key to reject the value.

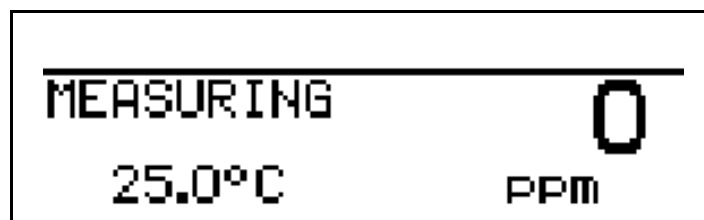

MEASURING 25.0°C 0 PPM

The instrument returns to the measurement mode.

9 Setup program

9.1 Function

Configurable parameters

The setup program (available as an option) can be used for easy adaptation of the instrument to the requirements.

- Setting the measurement range and the range limits.
- Setting the response of the outputs to an out-of-range signal.
- Setting the functions of the switching outputs K1 and K2.
- Setting the function of the binary input E1.
- Setting up special functions (e.g. tables for specific linearizations).
- etc.



Data transmission from or to the transmitter can only take place when it is connected to the electrical supply, see Chapter 4 "Electrical connection", page 12ff.

Connection



The setup interface is not electrically isolated.

When connecting the PC interface cable with a TTL/RS232 converter and adapter (**serial connection cable**) (70/00350260) , it is therefore absolutely essential to ensure that the supply for either the transmitter or the PC is **not** electrically earthed (for instance: use a battery-powered notebook).

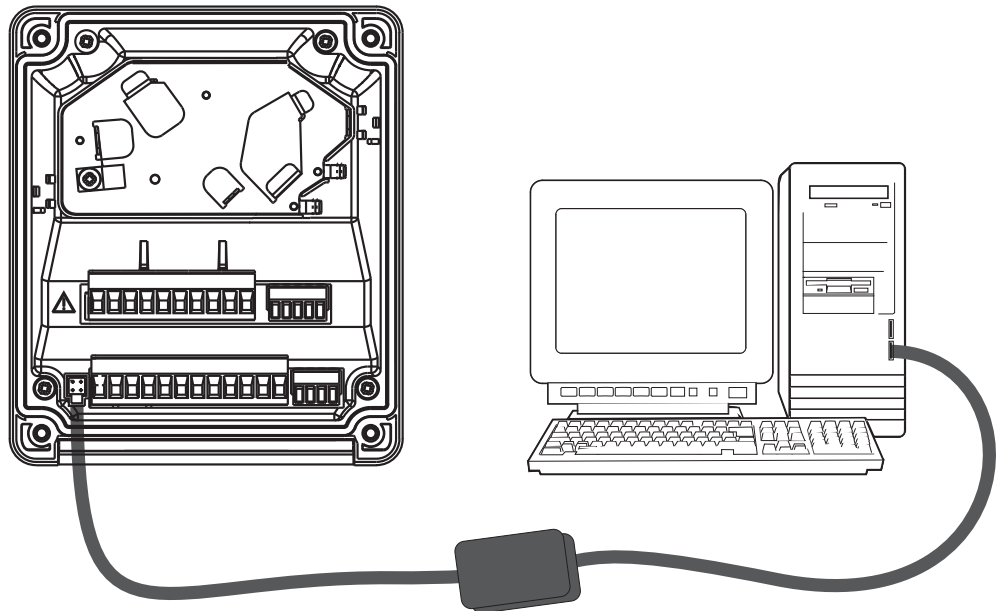

The PC interface cable with USB/TTL converter (**USB connection cable**) (70/00456352) is, however, electrically isolated.



PC interface with USB/TTL converter
(USB connection cable)
(70/00456352)

10 Eliminating faults and malfunctions

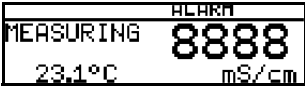
10.1 Possible faults

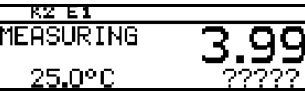
Problem	Possible cause	Measures
No measurement display or current output	Supply voltage missing	Check supply voltage, also check terminals
Measurement display 000 or analog output 0/4 mA or 0 V	Sensor not immersed in medium; reservoir level too low	Top up the reservoir
	Flow-through fitting is blocked	Clean flow-through fitting
	Sensor is faulty	Replace the sensor
Wrong or unstable measurement display	Sensor not immersed deeply enough	Top up the reservoir
	Inadequate mixing	Ensure good mixing; for sensor: all-round free space of approx. 5 mm to ensure all-round flow
	Air bubbles	Check mounting site
Measurement display 8888, Temperature display "ok", blinking 	Overrange / underrange or faulty sensor	Check the basic settings. Check the electrical connection for the sensor. Replace the instrument.
Measurement display 8888, temperature display 8888, blinking 	Infringement of temperature range (over/underrange), or short-circuit or cable break for the temperature sensor	The temperature for the measured medium is outside the permissible range for temperature compensation. Replace the instrument. Replace the sensor.
Temperature display and measurement display are normal, but the unit indicates "???" 	The basic settings were configured on the instrument in the "Customized" mode.	"Unit" must be configured through the setup program, or the "Customized" mode must be abandoned.
Fluctuating measurement display	Symmetrical connection was chosen. - Interruption of connection to liquid potential. - Interference potential too high.	- Check the electrical connection, see Chapter 4.5 "Terminal assignments", page 19 - Eliminate interference potential.

11 Appendix

11.1 Operator level parameters

If a number of instrument parameters have to be modified in the instrument, then it is advisable to note them in the table below, and then modify these parameters in the sequence given.



The following list shows the maximum number of parameters that can be altered.

Depending on the configuration, some of the parameters will not be visible, i.e. not alterable (editable) for your instrument.

Parameter	Selection / value range Factory setting	New setting
Controller channel 1		
Controller type	LIMIT PULSE WIDTH PULSE FREQ. CONTINUOUS MODULATING OFF	
Setpoint	depending on unit, e. g. -1.00 to 15.00 pH	
MIN / MAX contact (increasing / decreasing characteristic)	MIN CONTACT MAX CONTACT	
Proportional band	0 ...9999	
Reset time	0 ...9999	
Derivative time	0 ...999	
Pulse period	2,5... 20 ...999,5	
Minimum ON time	0,5 ...999,5	
Output level limit	0... 100 %	
Maximum pulse frequency	0... 60 1/min.	
Hysteresis (differential)	depending on unit, e. g. 0.00 to 16.00 pH	
Pull-in delay	0.00 – 999.5 sec	
Drop-out delay	0.00 – 999.5 sec	
Controller alarm	OFF ON	
Alarm tolerance	0,00... 1,00 ...16,00	
Alarm delay	0 ...9999	
In Hold mode	FROZEN 0% 100%	
In event of error	FROZEN 0% 100%	
MAX setpoint	depending on unit, e. g. -1.00 to 15.00 pH	
MIN setpoint	depending on unit, e. g. -1.00 to 15.00 pH	

11 Appendix

Parameter	Selection / value range Factory setting	New setting
Controller channel 2		
Controller type	LIMIT PULSE WIDTH PULSE FREQ. CONTINUOUS MODULATING OFF	
Setpoint	depending on unit, e. g. -1.00 to 15.00 pH	
MIN / MAX contact (increasing / decreasing characteristic)	MIN CONTACT MAX CONTACT	
Proportional band	0 ...9999	
Reset time	0 ...9999	
Derivative time	0 ...999	
Pulse period	2,5... 20 ...999,5	
Minimum ON time	0,5 ...999,5	
Output level limit	0... 100 %	
Maximum pulse frequency	0... 60 1/min.	
Hysteresis (differential)	depending on unit, e. g. 0.00 to 16.00 pH	
Pull-in delay	0.00 – 999.5 sec	
Drop-out delay	0.00 – 999.5 sec	
Controller alarm	OFF ON	
Alarm tolerance	0,00... 1,00 ...16,00	
Alarm delay	0 ...9999	
In Hold mode	FROZEN 0% 100%	
In event of error	FROZEN 0% 100%	
MAX setpoint	depending on unit, e. g. -1.00 to 15.00 pH	
MIN setpoint	depending on unit, e. g. -1.00 to 15.00 pH	
Controller special function		
I switch-off	INACTIVE ACTIVE	
Separate controllers	OFF ON	
Manual mode	LOCKED PULSED SWITCHED	
Input for pH / ORP		
for pH standard		
Zero point	5.0 to 9.0 to 9.00 pH	
Slope, acidic	75.0 to 100.0 to 110.0%	
Slope, alkaline	75.0 to 100.0 to 110.0%	

11 Appendix

Parameter	Selection / value range Factory setting	New setting
for pH antimony		
Zero point	-2.00 to 0.0 to 2.0 pH	
Slope, acidic	10.0 to 100.0 to 110.0%	
Slope, alkaline	10.0 to 100.0 to 110.0%	
for ORP		
Zero point	-199.9 to 0.0 to 199.9 mV	
for NH₃ (ammonia)		
Zero point	-450,0 to 138,0 to 450,0 mV	
for all measured variables		
Monit. ref.	OFF ON	
Monit. glass el.	OFF MIN IMPEDANCE MAX IMPEDANCE MIN.+MAX. IMP	
Filter time constant	0 – 2 – 25 sec	
Calibration interval	0 – 999 days (0 = switched off)	
Temperature input		
Sensor type	NO SENSOR Pt100/Pt1000 CUSTOMIZED	
Unit	°C °F	
Filter time constant	0 – 2 – 25 sec	
Manual temperature	-50 to 25 to 250°C	
Binary input		
Function	NO FUNCTION KEY LOCK HOLD MODE	

11 Appendix

Parameter	Selection / value range Factory setting	New setting
Switching output 1		
Function	NO FUNCTION CONTROLLER 1 CONTROLLER 2 CTRLR ALARM 1 CTRLR ALARM 2 CTRLR ALARM <input type="checkbox"/> LC1 MAIN VAR. <input type="checkbox"/> LC2 MAIN VAR. <input type="checkbox"/> LC7 MAIN VAR. <input type="checkbox"/> LC8 MAIN VAR. <input type="checkbox"/> LC1 TEMP. <input type="checkbox"/> LC2 TEMP. <input type="checkbox"/> LC7 TEMP. <input type="checkbox"/> LC8 TEMP. SENSOR ERROR CALIB. TIMER	
Manual mode	NO SIMULATION INACTIVE ACTIVE	
Switching output 2		
Function	NO FUNCTION CONTROLLER 1 CONTROLLER 2 CTRLR ALARM 1 CTRLR ALARM 2 CTRLR ALARM <input type="checkbox"/> LC1 MAIN VAR. <input type="checkbox"/> LC2 MAIN VAR. <input type="checkbox"/> LC7 MAIN VAR. <input type="checkbox"/> LC8 MAIN VAR. <input type="checkbox"/> LC1 TEMP. <input type="checkbox"/> LC2 TEMP. <input type="checkbox"/> LC7 TEMP. <input type="checkbox"/> LC8 TEMP. SENSOR ERROR CALIB. TIMER	

11 Appendix

Parameter	Selection / value range Factory setting	New setting
Manual mode	NO SIMULATION INACTIVE ACTIVE	
Analog output 1		
Signal selector	MAIN VARIABLE CONTROLLER 1 CONTROLLER 2	
Signal type	0 – 20 mA 20 – 0 mA 4 – 20 mA 20 – 4 mA 0 – 10 V 10 – 0 V	
Scaling start of principle measurement variable	depending on unit, e. g. -1 to 0.00 to 13.40 pH = 4 mA	
Scaling end of principle measurement variable	depending on unit, e. g. 0.60 to 15.00 pH = 20 mA	
During calibration	MOVING FROZEN SAFE VALUE	
In event of error	LOW HIGH FROZEN SAFE VALUE	
In Hold mode	LOW HIGH FROZEN SAFE VALUE	
Safe value	0 – 22 mA	
Simulation	OFF ON	
Simulation value	0 – 22 mA	
Analog output 2		
Signal selector	TEMPERATURE CONTROLLER 1 CONTROLLER 2	
Signal type	0 – 20 mA 20 – 0 mA 4 – 20 mA 20 – 4 mA 0 – 10 V 10 – 0 V	
Scaling start of temperature	-50 to +220°C = 4 mA	
Scaling end of temperature	-20 to +250°C = 20 mA	
During calibration	MOVING FROZEN SAFE VALUE	

11 Appendix









Parameter	Selection / value range Factory setting	New setting
In event of error	LOW HIGH FROZEN SAFE VALUE	
In Hold mode	LOW HIGH FROZEN SAFE VALUE	
Safe value	0 – 22 mA	
Simulation	OFF ON	
Simulation value	0 – 22 mA	
Display		
Language	GERMAN ENGLISH FRENCH	
Lighting	DURING OPERATION OFF	
LCD inverse	OFF ON	
Meas. display type	NORMAL TREND BAR GRAPH	
Lower display	TEMPERATURE OUTP. LEVEL 1 OUTP. LEVEL 2 SETPOINT 1 SETPOINT 2 NONE COMPENSATED UNCOMPENSATED	
Upper display	COMPENSATED UNCOMPENSATED TEMPERATURE OUTP. LEVEL 1 OUTP. LEVEL 2 SETPOINT 1 SETPOINT 2 NONE	
MIN/MAX reset	NO YES	
Operating timeout	0 – 10 min	
Contrast	0 – 10 – 20	

11 Appendix

11.2 Parameter explanations

FUNCTION

NO FUNCTION

-  Alarm window AF1 MAIN VAR.
-  Alarm window AF2 MAIN VAR.
-  Limit function AF7 MAIN VAR.
-  Limit function AF8 MAIN VAR.
-  Alarm window AF1 TEMP.
-  Alarm window AF2 TEMP.
-  Limit function AF7 TEMP.
-  Limit function AF8 TEMP.

SENSOR ERROR

CALIB. TIMER

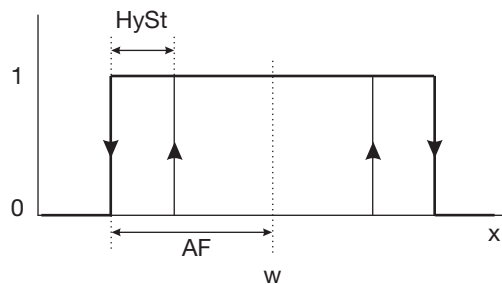

Alarm window AF1

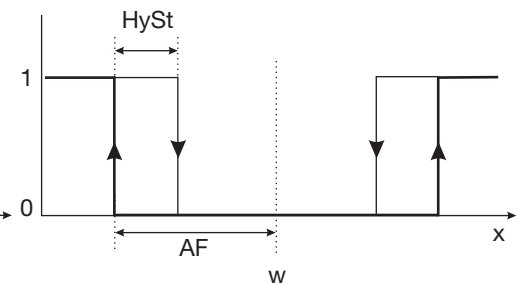

Alarm window AF2

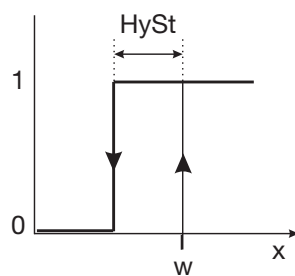

Limit function AF7

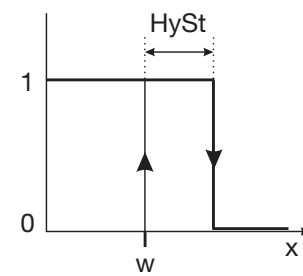

Limit function AF8

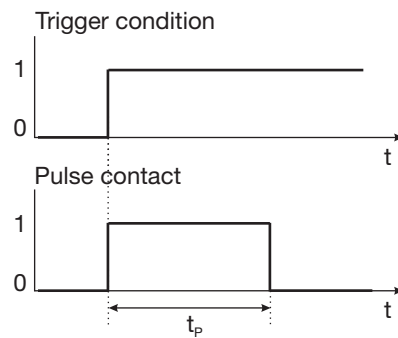

Pulse contact
Triggering condition longer than
pulse duration

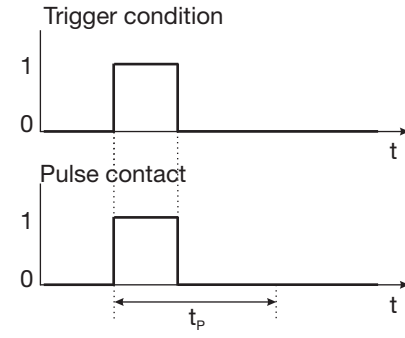

Pulse contact
Triggering condition shorter than
pulse duration

0	Off	t	Time
1	On	t_p	Pulse duration
AL	Spacing	w	Setpoint / Limit
HySt	Hysteresis	x	Actual value / Measurement value

MEAS. DISPLAY TYPE

NORMAL
 TREND
 BAR GRAPH

NORMAL

In the normal display, the pH is shown (compensated for the reference temperature) or the concentration and temperature of the medium being measured.

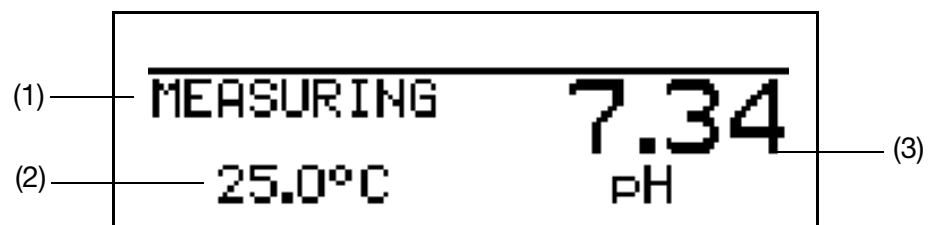

- (1) Operating mode
- (2) Lower display
- (3) Upper display

11 Appendix

TREND

The operator can quickly recognize in which direction the measurement is changing.

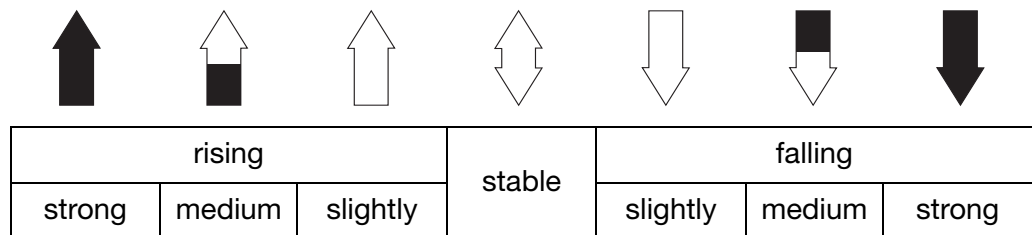
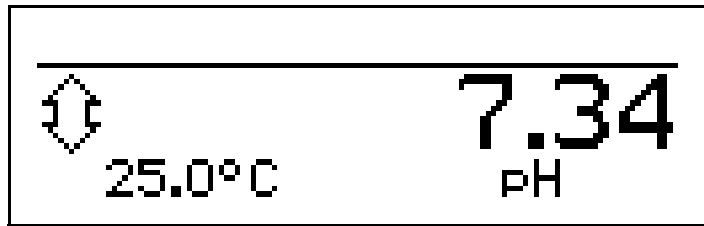

The measurement trend is derived from the last 10 measurements. With a 500 msec sampling cycle, this means that the last 5 seconds are taken into account.

BAR GRAPH

- The measurement is shown as a moving bar.
- There is no temperature display.
- On instruments with configurable control contacts, the setpoints are marked by arrows above the bar graphs.

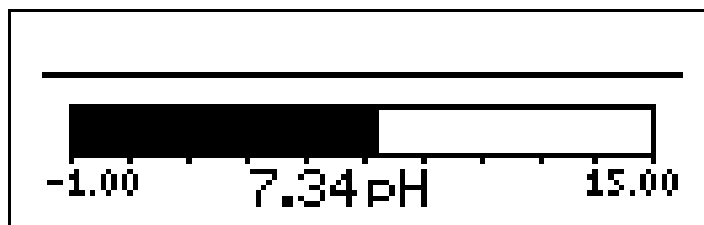

Scaling of the bar

- * Activate the measurement display type BAR GRAPH.
- * Select BARGR. SCALE START.
- * Confirm selection with .
- * Use the or key to enter the lower limit for the range to be displayed.
- * Confirm selection with .
- * Select BARGR. SCALE END
- * Use the or key to enter the upper limit for the range to be displayed.

* Confirm selection with .



In order to return to the measurement mode:
Press the  key several times, or wait for the timeout.

LOWER DISPLAY

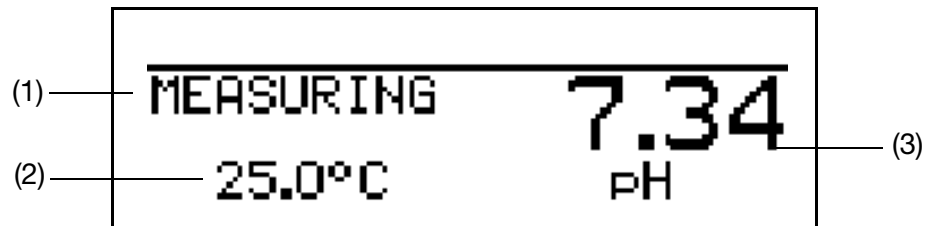

- (1) Operating mode
- (2) Lower display
- (3) Upper display

This parameter is only available for the measurement display types NORMAL and TREND.

TEMPERATURE

OUTP. LEVEL 1
OUTP. LEVEL 2
SETPOINT 1
SETPOINT 2
NONE
COMPENSATED
UNCOMPENSATED

UPPER DISPLAY

This parameter is only available for the measurement display types NORMAL and TREND.

COMPENSATED

UNCOMPENSATED
TEMPERATURE
OUTP. LEVEL 1
OUTP. LEVEL 2
SETPOINT 1
SETPOINT 2
NONE

11 Appendix

11.3 Glossary

Calibration timer

The calibration timer indicates (if required) when the next routine calibration is due. The calibration timer is activated by entering a number of days, after which recalibration has to be carried out (plant or operator requirement).

MIN/MAX value memory

This memory acquires the minimum or maximum input variables that have occurred. This information serves, for example, to decide whether the sensor that is connected is suited to the values that are actually present. .

The MIN/MAX value memory can be reset: Operator level / Display / MIN/MAX value memory / Yes, see "Operator level parameters", page 84ff.

Asymmetrical connection of pH electrodes

pH electrodes are usually connected to the transmitter asymmetrically. The connection corresponds precisely to the arrangement of a pH electrode with regard to the impedance.

In the case of the asymmetrical connection, the glass electrode has a high-resistance connection to the transmitter electronics and the reference electrode a low-resistance one. Most transmitters are designed for this type of connection.

For both asymmetrical and symmetrical connections, the input impedance of the transmitter must be about 1000 times higher than the impedance of the glass electrode that is connected. The impedance of a glass electrode can be up to 1000 MOhm.

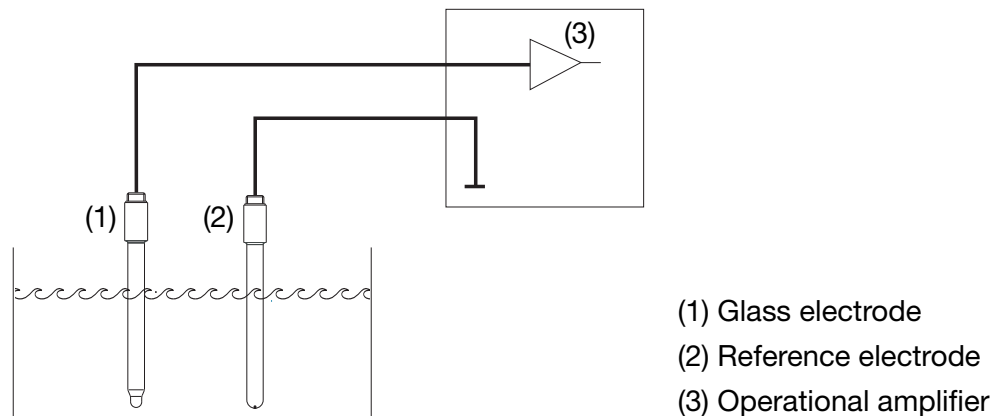

Symmetrical connection of pH electrodes

The symmetrical high-resistance input is an alternative method of connecting pH electrodes to a transmitter. In this case, both glass and reference electrode have a high-resistance connection to the transmitter. This connection type makes it imperative to make an additional connection of the liquid potential to

the transmitter.

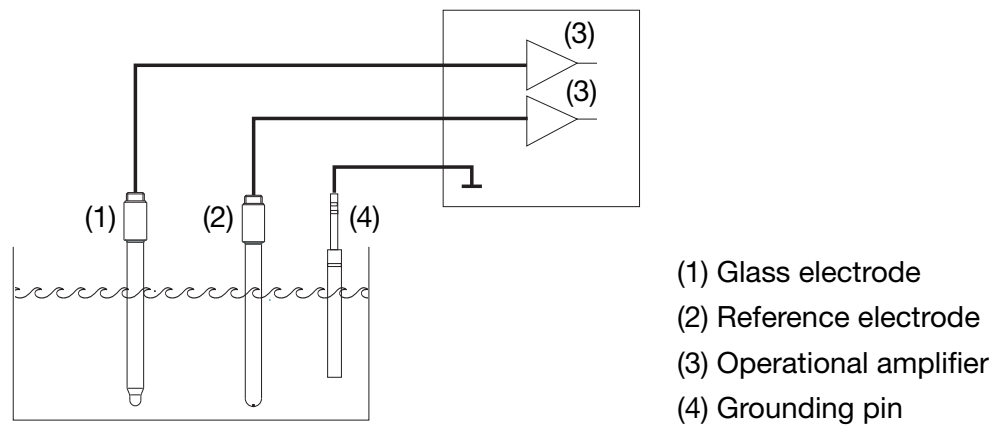

With the symmetrical connection, even difficult electrical ambient conditions can be compensated.

If, for example, an electric motor for a mixer conducts a fault current into the substance being measured, this will result in a potential shift with regard to the system ground.

With the usual asymmetrical connection, a fault current may flow to the system ground via the stray capacitance (which occurs in all instruments), thus causing a measurement error.

In case of the symmetrical connection, both inputs are fed to the instrument electronics via operational amplifiers. These operational amplifiers cancel the fault current (up to a certain degree), thereby preventing measurement errors.

Impedance monitoring

Impedance monitoring of glass pH combination electrodes make high demands on the transmitter electronics. The measurement needed for this is performed in parallel to the acquisition of the main measurement variable. To minimize the load on the electrode, the reaction time may be up to a minute.

With the asymmetrical connection of the glass and reference electrode, the cumulative impedance can be monitored.

Monitoring the reference electrode is not recommended, since the measured value is difficult to interpret.

Impedance measurement depends on the cable material, cable length and the components that are used. Special JUMO cables for pH measurement may be up to 10 m long.

If ISFET sensors or impedance converters are used, then impedance monitoring is not possible.

11 Appendix

Pulse width controller (output is active for $X > W$ and a P control structure)

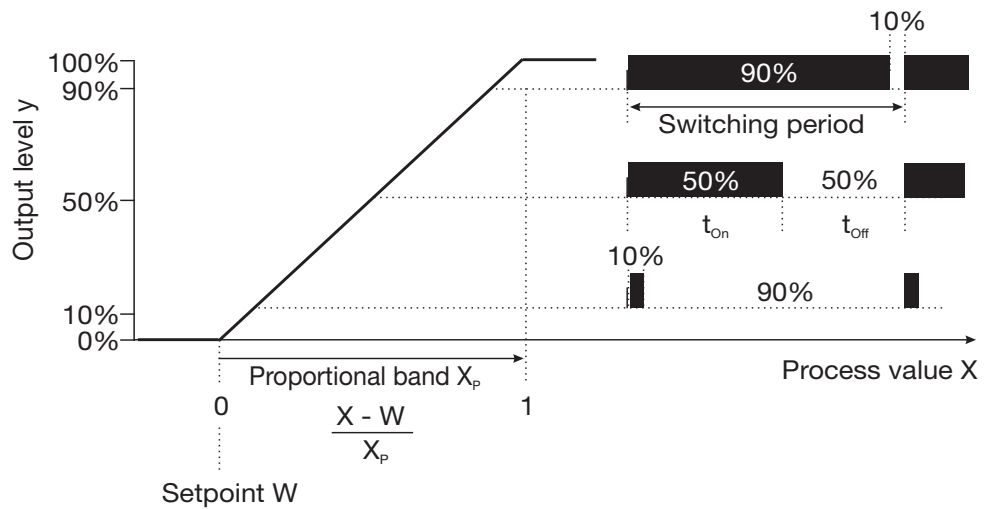

If the process value X exceeds the setpoint W , the P controller will control proportionally to the control deviation. On going outside the proportional band, the controller operates with an output level of 100% (100% duty cycle).

Pulse frequency controller (output is active for $X > W$ and a P control structure)

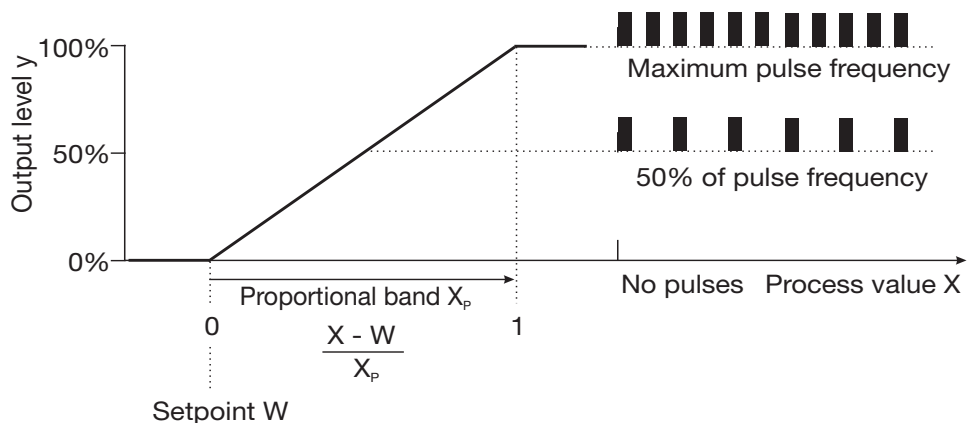

If the process value X exceeds the setpoint W , the P controller will control proportionally to the control deviation. On going outside the proportional band, the controller operates with an output level of 100% (max. switching frequency).

Special controller functions

The following functions can be activated in this menu:

- Manual mode (activate controller outputs manually), see section 6.6 "MANUAL mode / simulation mode", page 33
- Separate controllers (see below)
- I-component switch-off (see below)

Separate controllers

This function is normally deactivated (factory setting or "No" selection).

In the deactivated state, the software prevents the two controller outputs from being able to work "against each other". So, for example, it is not possible to dose acid and lye at the same time.

If the controllers are separate ("Yes" selection), each controller can be freely configured.

I-component switch-off

This function is normally deactivated (factory setting or "No" selection).

In the deactivated state, the controller works in accordance with general controller theory.

When I-component switch-off is activated ("Yes" selection), the part of the output level that can be traced back to the I-component is set to zero when the setpoint is reached.

This can be useful with mutual neutralization (acid and lye dosing both possible) in one treatment tank.

Wash timer

The wash timer can be used to implement automated sensor cleaning. This function is assigned to a switching output (1 or 2) for that purpose.

The cycle duration (cleaning interval) can be adjusted in the range from 1 to 240 hours. The wash duration (cleaning duration) is adjustable from 1 to 1800 seconds. During the wash duration the controller goes into the HOLD state, which is maintained for 10 seconds after completion of the wash duration. A sensor calibration within the cycle duration restarts the wash timer.

The wash timer is deactivated with the "0" cycle duration.

12 Instrument description

12.1 Technical data

12.1.1 Inputs

Main input	Measurement/control range	Accuracy	Temperature error
pH	-1 to 15 pH	≤ 0.3%	0.2%/10°C
ORP	-1500 to 1500 mV	≤ 0.3%	0.2%/10°C
NH ₃ (ammonia)	0 to 9999 ppm	≤ 0.3%	0.2%/10°C
Secondary input			
Temperature Pt100/1000 (automatic detection)	-10 to 150°C ¹	≤ 0.5°C	0.05%/10°C
Temperature NTC/PTC	4 kΩ max. Input via table with 20 value pairs	≤ 0.3%	0.05%/10°C

12.1.2 Temperature compensation

Measured variable	Compensation	Range ²
pH	yes	-10 to 150°C
ORP	no	not applicable
NH ₃ (ammonia)	yes	-10 to 150°C

12.1.3 Measuring circuit monitoring

Inputs	Over/underrange	Short-circuit	Cable break
pH	yes	yes ³	yes ³
ORP	yes	no	no
NH ₃ (ammonia)	yes	no	no
Temperature	yes	yes	yes

12.1.4 Impedance measurement

Impedance measurement can optionally be activated.

Since it depends on some marginal parameters, the following points must be noted:

- Only glass-based sensors are permissible (no ISFET or antimony electrodes).
- The sensors must be directly connected to the transmitter.

It is not permissible to use an impedance converter in the measuring circuit !

- The maximum permissible cable length between sensor and transmitter is 10 m.
- Liquid impedances will directly influence the measurement result.

We therefore recommend activating the measurement in liquids from about 100 µS/cm conductivity upwards.

12.1.5 Binary input

Activation	through floating contact
Function	Key inhibit HOLD Alarm suppression

¹ Switchable to °F

² Please note operating temperature range of sensor !

³ In the case of pH measurement, the sensor can be monitored for short-circuit and cable break by activating the impedance measurement.

12 Instrument description

12.1.6 Controller

Controller type	limit comparators, limit controller, pulse width controller, pulse frequency controller, modulating controller, continuous controller
Controller action	P / PI / PD / PID
A/D converter	dynamic resolution up to 14-bit
Sampling time	500 msec

12.1.7 Analog outputs (one or two)

Output mode	Signal range	Accuracy	Temperature error	Permissible load resistance
Current signal	0/4 – 20 mA	≤ 0.25%	0.08%/10 °C	≤ 500Ω
Voltage signal	0 – 10 V	≤ 0.25%	0.08%/10 °C	≥ 500 Ω

The analog outputs respond in accordance with the recommendation as per NAMUR NE43.
They are electrically isolated, 30 V AC / 50 V DC.

12.1.8 Switching outputs (two changeover (SPDT) max.)

Rated load	3 A/250 VAC (resistive load)
Contact life	>2×10 ⁵ operations at rated load

12.1.9 Supply voltage for ISFET

±5 V DC; 5 mA

12.1.10 Setup interface

Interface for configuring the instrument through the optionally available setup program (for instrument configuration only).

12.1.11 Electrical data

Supply voltage	110 – 240 V AC; -15/+10%; 48 – 63 Hz 20 – 30 V AC/DC; 48 – 63 Hz 12 – 24 V DC +/-15% (permissible for connection to SELV/PELV circuits only)
Power consumption	approx. 14 VA
Electrical safety	EN 61 010, Part 1 overvoltage category III ¹ , pollution degree 2
Data backup	EEPROM
Electrical connection	pluggable screw terminals conductor cross-section up to 2.5 mm ² (supply, relay outputs, sensor inputs) conductor cross-section up to 1.5 mm ² (analog outputs; ISFET supply)

¹ Not valid with protective extra-low voltage (PELV) of power supply variant 12 – 24 V DC.

12 Instrument description

12.1.12 Housing

Material	ABS
Cable entry	cable glands, 3xM16 and 2xM12 max.
Special feature	venting device to prevent condensation
Ambient temperature range (the specified accuracy is adhered to within this range)	-10 to 50°C
Operating temperature range (instrument is operational)	-15 to 65°C
Storage temperature range	-30 to 70°C
Climatic conditions	rel. humidity ≤ 90% annual mean, no condensation (following EN 60721 3-3 3K3)
Enclosure protection as per EN 60529	in surface-mountable housing: IP67 for panel mounting: IP65 front, IP20 rear
Vibration strength	as per EN 60068-2-6
Weight	surface-mountable housing: approx. 900 g for panel mounting: approx. 480 g
Dimensions	see dimensioned drawings on page 8.

12.1.13 Standard accessories

Cable glands
Internal mounting material
Operating Instructions

12.1.14 Approvals/marks of conformity

Mark of conformity	Testing laboratory	Certificates/certification numbers	Test basis	valid for
c UL us	Underwriters Laboratories	E 201387	UL 61010-1	all types

12.2 Panel cut-out

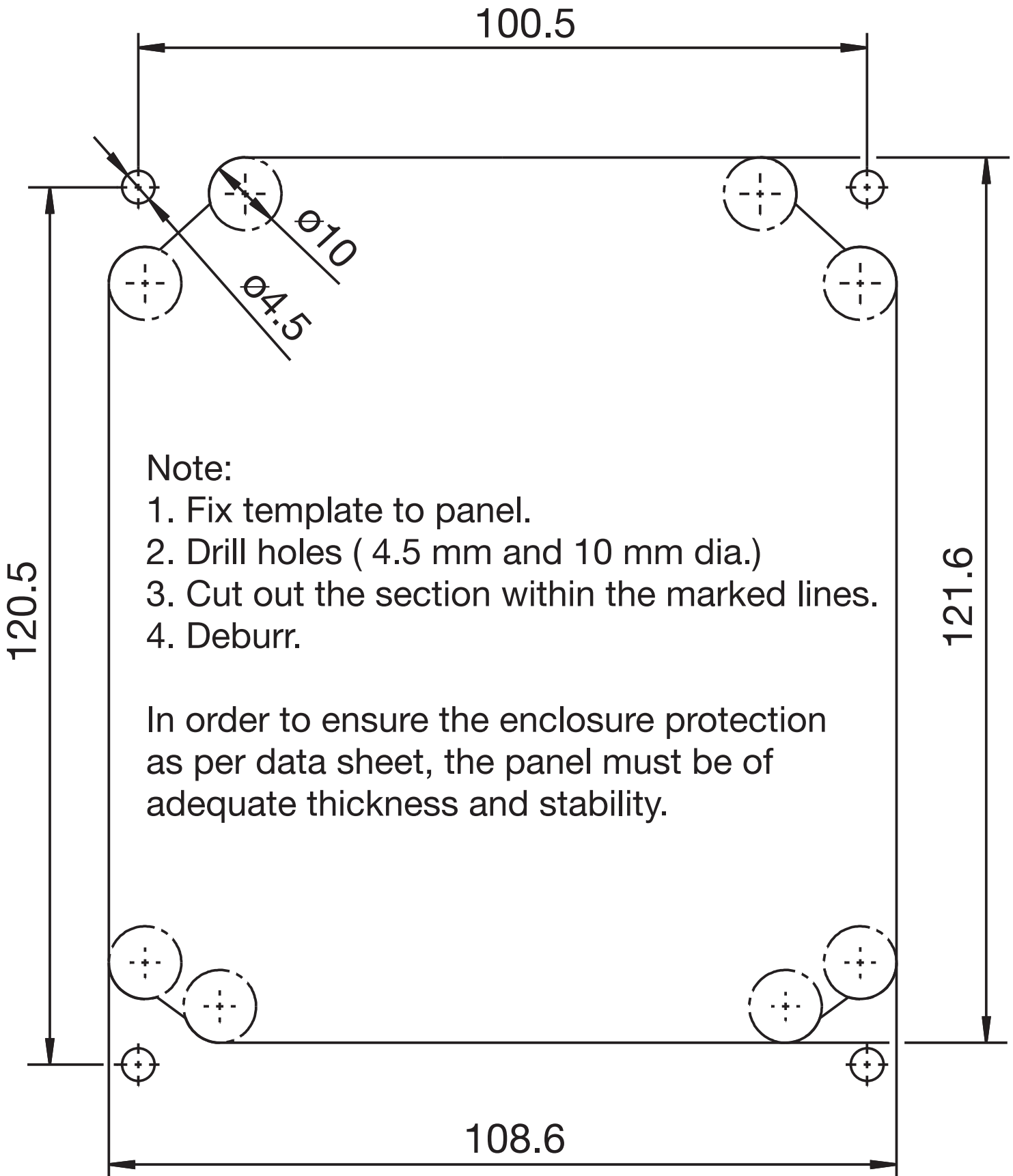



JUMO GmbH & Co. KG

Street address:
Moritz-Juchheim-Straße 1
36039 Fulda, Germany
Delivery address:
Mackenrodtstraße 14
36039 Fulda, Germany
Postal address:
36035 Fulda, Germany
Phone: +49 661 6003-0
Fax: +49 661 6003-607
E-mail: mail@jumo.net
Internet: www.jumo.net

JUMO Instrument Co. Ltd.

JUMO House
Temple Bank, Riverway
Harlow - Essex CM20 2DY, UK
Phone: +44 1279 63 55 33
Fax: +44 1279 63 52 62
E-mail: sales@jumo.co.uk
Internet: www.jumo.co.uk

JUMO Process Control, Inc.

8 Technology Boulevard
Canastota, NY 13032, USA
Phone: 315-697-5866
1-800-554-JUMO
Fax: 315-697-5867
E-mail: info@jumo.us
Internet: www.jumo.us