

JUMO GmbH & Co. KG

Delivery address: Mackenrodtstraße 14
36039 Fulda, Germany
Postal address: 36035 Fulda, Germany
Phone: +49 661 6003-0
Fax: +49 661 6003-607
E-mail: mail@jumo.net
Internet: www.jumo.net

JUMO Instrument Co. Ltd.

JUMO House
Temple Bank, Riverway
Harlow, Essex CM20 2DY, UK
Phone: +44 1279 635533
Fax: +44 1279 635262
E-mail: sales@jumo.co.uk
Internet: www.jumo.co.uk

JUMO Process Control, Inc.

6733 Myers Road
East Syracuse, NY 13057, USA
Phone: 315-437-5866
1-800-554-5866
Fax: 315-437-5860
E-mail: info.us@jumo.net
Internet: www.jumousa.com



JUMO tecLine pH, JUMO tecLine Rd

pH and redox combination electrodes in glass or plastic shaft versions

201020 series - pH electrodes

201025 series - redox electrodes

Brief description

JUMO tecLine electrodes are high-quality sensors for professional applications in process and industrial measurement technology. These electrodes are known for their use of top-quality materials and components. They are designed as combined electrodes (the glass or metal electrode and the reference electrode are combined in one shaft). A temperature probe can also be integrated as an option, depending on the type.

Suitable versions are available to meet a wide variety of requirements:

JUMO tecLine

- for industrial and communal water and wastewater engineering
- for measurements in suspensions and varnishes
- for measurements in low-ion media
- for high-alkaline, high-temperature and sterilization processes
- for media containing fluorides and low-temperature applications
- PRO version for the toughest operating conditions

JUMO tecLine sensors are state-of-the-art for modern pH and redox electrodes. Each electrode is a quality product and is individually tested as a matter of routine. Modern production facilities ensure consistent characteristics.

General information about the construction of the JUMO tecLine series

All standard electrodes are made from physiologically safe and FDA-listed materials. The sensors are equipped with lead-free shaft glass and are therefore conform to RoHS.



JUMO GmbH & Co. KG
 Delivery address: Mackenrodtstraße 14
 36039 Fulda, Germany
 Postal address: 36035 Fulda, Germany
 Phone: +49 661 6003-0
 Fax: +49 661 6003-607
 E-mail: mail@jumo.net
 Internet: www.jumo.net

JUMO Instrument Co. Ltd.
 JUMO House
 Temple Bank, Riverway
 Harlow, Essex CM20 2DY, UK
 Phone: +44 1279 635533
 Fax: +44 1279 635262
 E-mail: sales@jumo.co.uk
 Internet: www.jumo.co.uk

JUMO Process Control, Inc.
 6733 Myers Road
 East Syracuse, NY 13057, USA
 Phone: 315-437-5866
 1-800-554-5866
 Fax: 315-437-5860
 E-mail: info.us@jumo.net
 Internet: www.jumousa.com



Active element of pH and redox electrodes

Membrane glass or active component	Designation	pH or redox range	Temperature range	Typical application
UW glass	universal glass	pH 0 to 12 (briefly pH 14)	-5 to +80 °C	Water and wastewater engineering, process measurement technology, low-ion media
HA glass	high-alkaline glass	pH 0 to 14	-5 to +80 °C	For heavily alkaline media (above pH 12)
HT glass	high-temperature glass	pH 0 to 14	0 to 135 °C	For temperatures above 80 °C or for heavily alkaline media
DS glass	steam-sterilizable glass	pH 0 to 12	-5 to +80 °C briefly up to 130 °C (20 min)	Biotechnology, pharmaceutical and food technology, sterilization processes
C glass	fluoride-resistant glass	pH 0 to 11	-5 to +50 °C	Media containing fluorides (hydrofluoric acid) (c(HF) ≤ 1000 mg/l)
Platinum tip	redox measurement	±2000 mV	-10 to +135 °C	Chromate reduction, nitrite oxidation, swimming pool and drinking water disinfection
Gold tip	redox measurement	±2000 mV	-10 to +135 °C	Cyanide oxidation, water disinfection

Reference system design variations (reference electrode)

The only reference electrolytes used for JUMO tecLine electrodes are those that have no silver ions. A cartridge-style conduction system contains the silver/silver chloride (Ag/AgCl). Various forms of diaphragm are used.

Diaphragm type	Explanation	Possible electrolytes	Typical application/ limitations
1x ceramic diaphragm	High-quality zirconium dioxide diaphragm ^a	Highly viscous KCl gel or liquid KCl	General water or wastewater engineering, industrial processes, etc.
3x ceramic diaphragm	As above, but the increased number means more KCl escapes	Highly viscous KCl gel or liquid KCl.	For polluted or low-ion media (LF <100 µS/cm); low-temperature applications
Glass fiber diaphragm	Glass fiber bundle instead of a ceramic diaphragm for electrodes with a plastic shaft	Highly viscous KCl gel	General water or wastewater engineering (lightly polluted media)
PTFE ring diaphragm	Large surface area ring diaphragm	Highly viscous KCl gel	Only for very heavily polluted media or adherent media containing oil, for example
Annular-gap or perforated diaphragm	Open transition between the solid electrolyte and the medium, implemented in annular or punctate form	Polymerized solid electrolyte	Suspensions, varnishes, media containing solids, heavily polluted media; not suitable for very pure drinking water or low-ion media
Doka types (two-chamber system)	The extended diffusion path and double diaphragm separation prevent electrode poisoning	Highly viscous gel KCl/KCl bridge	For when electrode poisons are present (e.g. sulphides)
		Solid electrolyte	

^a Zirconium dioxide diaphragm: high-quality ceramic material of consistent porosity. This means optimum diffusion properties.

Other pH and redox electrodes can be found in the following data sheets:

- Data sheet 201005: JUMO ecoLine pH/Rd
- Data sheet 201030: JUMO labLine or
- Data sheet 201080: JUMO single sensors

JUMO GmbH & Co. KG

Delivery address: Mackenrodtstraße 14
36039 Fulda, Germany
Postal address: 36035 Fulda, Germany
Phone: +49 661 6003-0
Fax: +49 661 6003-607
E-mail: mail@jumo.net
Internet: www.jumo.net

JUMO Instrument Co. Ltd.

JUMO House
Temple Bank, Riverway
Harlow, Essex CM20 2DY, UK
Phone: +44 1279 635533
Fax: +44 1279 635262
E-mail: sales@jumo.co.uk
Internet: www.jumo.co.uk

JUMO Process Control, Inc.

6733 Myers Road
East Syracuse, NY 13057, USA
Phone: 315-437-5866
1-800-554-5866
Fax: 315-437-5860
E-mail: info.us@jumo.net
Internet: www.jumousa.com



JUMO tecLine pH/Rd

pH and redox combination electrodes with ceramic or glass fiber diaphragm for water and process measurement technology

Typical areas of application

- Industrial and communal, as well as general water and wastewater engineering
- Process measurements, electroplating plants, final inspections, neutralization plants
- Drinking and well water, boiler feed water
- Lightly polluted wastewater
- Two-chamber system for when electrode poisons (e.g. sulphides, cyanides) are present
- Low-temperature applications (-30 to +30 °C), e.g. measurement in cooling systems
- Media containing fluorides (hydrofluoric acid) up to 1000 mg/l HF
- High-alkaline applications (reduced alkaline error at pH values > pH 12)

Key features

- High-quality zirconium dioxide diaphragms (glass fiber diaphragm for plastic shaft)
- Cartridge-style conduction system with a reference electrolyte with no silver ions
- Pressure-resistant versions up to 10 bar (50 °C)
- Temperature range: up to -5 to +80 °C (90 °C for redox) or -30 to +30 °C (for TT version)
- Temperature probe integration options
- Salt reserve option for increasing service life in media with lower conductivity or in drinking water
- JUMO HA glass for continuous measurements in the up to pH 14 range
- Redox versions with a platinum or gold tip up to ±2000 mV

Extra code

Salt reserve, extra code 837

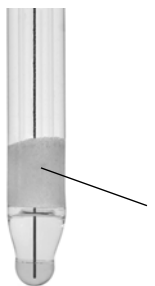

The option is available to equip the electrode with a salt reserve, in the form of four salt rings (see illustration). This is recommended when using the electrode in media with fewer ions or at high flow rates. The salt reserve helps to increase the service life of the electrode. The rings are not a manufacturing defect (crystallization).

JUMO GmbH & Co. KG
 Delivery address: Mackenrodtstraße 14
 36039 Fulda, Germany
 Postal address: 36035 Fulda, Germany
 Phone: +49 661 6003-0
 Fax: +49 661 6003-607
 E-mail: mail@jumo.net
 Internet: www.jumo.net

JUMO Instrument Co. Ltd.
 JUMO House
 Temple Bank, Riverway
 Harlow, Essex CM20 2DY, UK
 Phone: +44 1279 635533
 Fax: +44 1279 635262
 E-mail: sales@jumo.co.uk
 Internet: www.jumo.co.uk

JUMO Process Control, Inc.
 6733 Myers Road
 East Syracuse, NY 13057, USA
 Phone: 315-437-5866
 1-800-554-5866
 Fax: 315-437-5860
 E-mail: info.us@jumo.net
 Internet: www.jumousa.com



Dimensions

Type 20102x/51

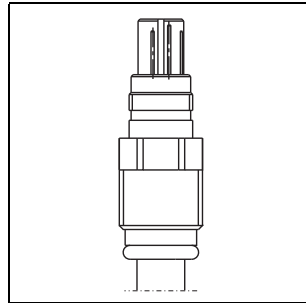
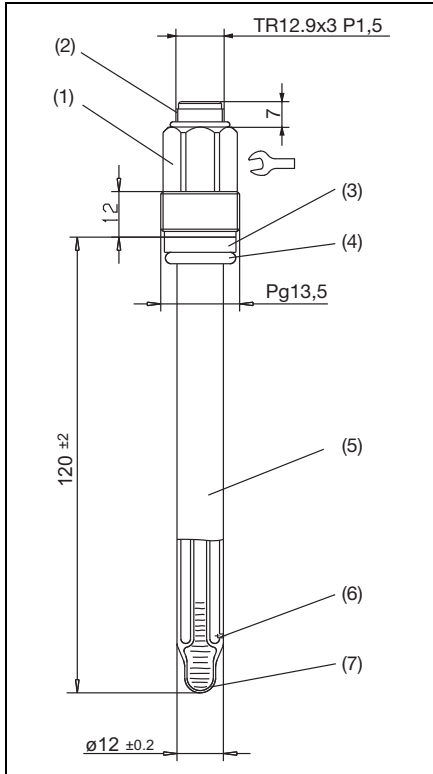

VP Pg13.5 screw cap

- (1) Pg13.5 screw cap
(max. tightening torque 3 Nm)
- (2) TR12.9 × 3 P1.5 thread
- (3) Ring (PSU)
- (4) O-Ring 10 × 3,5 (FPM70)
- (5) Electrode shaft (DIN19263 glass)
- (6) 1 to 3 diaphragms
(zirconium dioxide Ø 1 mm)
- (7) Rounded membrane

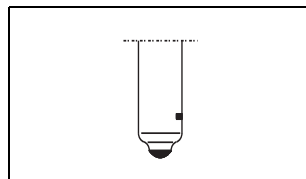

Platinum or gold tip
type 201025/...

Type 20102x/74

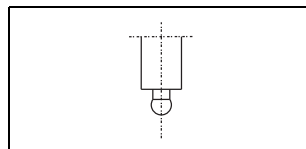
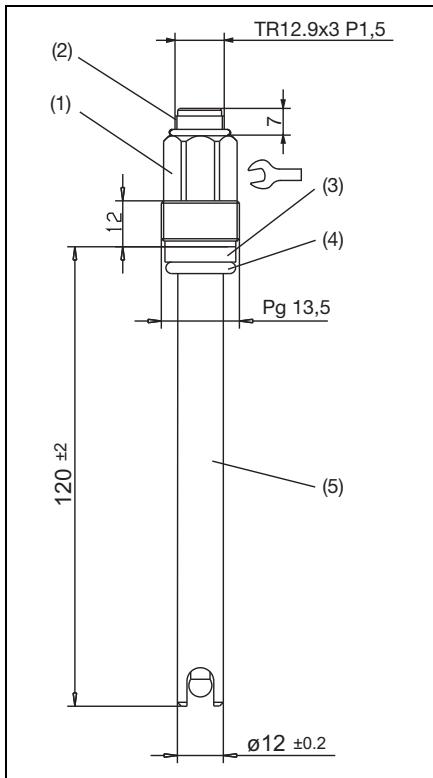

pH, no protection basket

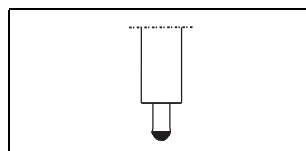

Platinum or gold tip
type 201025/74

- (1) Pg13.5 screw cap
(max. tightening torque 3 Nm)
- (2) TR12.9 × 3 P1.5 thread
- (3) Ring (PSU)
- (4) O-ring 10 × 3.5 (FPM70)
- (5) Electrode shaft (plastic PSU)

JUMO GmbH & Co. KG
 Delivery address: Mackenrodtstraße 14
 36039 Fulda, Germany
 Postal address: 36035 Fulda, Germany
 Phone: +49 661 6003-0
 Fax: +49 661 6003-607
 E-mail: mail@jumo.net
 Internet: www.jumo.net

JUMO Instrument Co. Ltd.
 JUMO House
 Temple Bank, Riverway
 Harlow, Essex CM20 2DY, UK
 Phone: +44 1279 635533
 Fax: +44 1279 635262
 E-mail: sales@jumo.co.uk
 Internet: www.jumo.co.uk

JUMO Process Control, Inc.
 6733 Myers Road
 East Syracuse, NY 13057, USA
 Phone: 315-437-5866
 1-800-554-5866
 Fax: 315-437-5860
 E-mail: info.us@jumo.net
 Internet: www.jumousa.com



Order details

	(1) Basic type	
	201020	JUMO tecLine pH - pH combination electrodes for water and process measurement technology
	201025	JUMO tecLine Rd - redox combination electrodes for water and process measurement technology
	(2) Basic type extension	
x	51	Glass shaft, gel-sealed/cartridge-style conduction system
o	72	PEI plastic shaft with protection basket, gel-sealed, glass filament diaphragm, cartridge-style conduction system
o	73	PSU plastic shaft without protection basket, gel-sealed, glass filament diaphragm, cartridge-style conduction system ^a
o	74	PSU plastic shaft with protection basket, gel-sealed, glass filament diaphragm, cartridge-style conduction system ^a
	(3) Active component	
x	18	UW glass, pH 0 - 12 (briefly 14), -5 to +80 °C
o	11	C glass, pH 0 - 12, -5 to +50 °C, fluoride-resistant up to 1000 mg HF/l
o	17	HA glass, pH 0 - 14, -5 to +80 °C, high-alkaline use
x	22	Platinum tip, redox range ±2000 mV, -5 to +90 °C
o	32	Gold tip, redox range ±2000 mV, -5 to +90 °C
	(4) Diaphragm	
o	05	1× glass filament diaphragm ^b
x	07	1× zirconium dioxide diaphragm (special ceramic)
o	09	3× zirconium dioxide diaphragm (special ceramic)
	(5) Connection	
o	18	VP Pg13.5 screw cap ^c
x	22	Pg13.5. screw cap
	(6) Fitting length	
x	120	120 mm (standard)
o	225	225 mm
		Other length on request
	(7) Extra codes	
o	000	None
x	837	Salt reserve
o	838	Two-chamber system (DOKA) with KCl/KCl bridge
o	840	Pt100 temperature probe
o	841	Pt1000 temperature probe

^a Only available in fitting length 225.

^b Only for basic type extension 72, 73 or 74.

^c For electrodes with extra code 840 or 841.

x = as standard
 o = option

Order code (1) (2) (3) (4) (5) (6) (7) , ...^a
Order example 201020 / 51 - 18 - 07 - 22 - 120 / 837

^a List extra codes in sequence, separated by commas.

Note:

The type code is not a modular system.

If possible, choose items listed under "**stock versions**" or "**production versions**" for your orders.

We will have to technically inspect and approve a free combination of individual key features.

JUMO GmbH & Co. KG

Delivery address: Mackenrodtstraße 14
36039 Fulda, Germany
Postal address: 36035 Fulda, Germany
Phone: +49 661 6003-0
Fax: +49 661 6003-607
E-mail: mail@jumo.net
Internet: www.jumo.net

JUMO Instrument Co. Ltd.

JUMO House
Temple Bank, Riverway
Harlow, Essex CM20 2DY, UK
Phone: +44 1279 635533
Fax: +44 1279 635262
E-mail: sales@jumo.co.uk
Internet: www.jumo.co.uk

JUMO Process Control, Inc.

6733 Myers Road
East Syracuse, NY 13057, USA
Phone: 315-437-5866
1-800-554-5866
Fax: 315-437-5860
E-mail: info.us@jumo.net
Internet: www.jumousa.com

**pH stock versions**

(delivery 3 working days after receipt of order)

Typ	Brief description	Part no.
201020/51-18-07-22-120/837	Glass shaft, gel-sealed, zirconium dioxide diaphragm, screw cap, 120 mm, salt reserve	00300151
201020/51-18-07-22-120/000	Glass shaft, gel-sealed, zirconium dioxide diaphragm, screw cap, 120 mm	00300148
201020/51-18-07-18-120/837, 840	Glass shaft, gel-sealed, zirconium dioxide diaphragm, VP screw cap, 120 mm, salt reserve, integrated Pt100	00595184
201020/51-17-07-22-120/837	Glass shaft, gel-sealed, zirconium dioxide diaphragm, screw cap, 120mm (high-alkaline applications)	00408953
201020/74-18-05-22-225/000	PSU plastic shaft with protection basket, gel-sealed, glass filament diaphragm, screw cap, 225 mm	00354295
201020/73-18-05-22-225/000	PSU plastic shaft without protection basket, gel-sealed, glass filament diaphragm, screw cap, 225 mm	00330857
201020/72-18-05-22-120/837, 838	PEI plastic shaft with protection basket, gel-sealed, glass filament diaphragm, screw cap, 120 mm, salt reserve, two-chamber system	00303398

pH production versions

(delivery 10 working days after receipt of order)

Typ	Brief description	Part no.
201020/51-18-07-22-225/000	Glass shaft, gel-sealed, zirconium dioxide diaphragm, screw cap, 225 mm	00399535
201020/51-11-07-22-120/000	Glass shaft, gel-sealed, zirconium dioxide diaphragm, screw cap, 120 mm	00375623

Redox stock versions

(delivery 3 working days after receipt of order)

Typ	Brief description	Part no.
201025/51-22-07-22-120/837	Glass shaft, gel-sealed, platinum tip, zirconium dioxide diaphragm, screw cap, 120 mm, salt reserve	00300397
201025/51-32-07-22-120/837	Glass shaft, gel-sealed, gold tip, zirconium dioxide diaphragm, screw cap, 120 mm, salt reserve	00300396
201025/72-22-05-22-120/837, 838	PEI plastic shaft without protection basket, gel-sealed, platinum tip, glass filament diaphragm, screw cap, 120 mm, salt reserve, two-chamber system	00084011

JUMO GmbH & Co. KG

Delivery address: Mackenrodtstraße 14
36039 Fulda, Germany
Postal address: 36035 Fulda, Germany
Phone: +49 661 6003-0
Fax: +49 661 6003-607
E-mail: mail@jumo.net
Internet: www.jumo.net

JUMO Instrument Co. Ltd.

JUMO House
Temple Bank, Riverway
Harlow, Essex CM20 2DY, UK
Phone: +44 1279 635533
Fax: +44 1279 635262
E-mail: sales@jumo.co.uk
Internet: www.jumo.co.uk

JUMO Process Control, Inc.

6733 Myers Road
East Syracuse, NY 13057, USA
Phone: 315-437-5866
1-800-554-5866
Fax: 315-437-5860
E-mail: info.us@jumo.net
Internet: www.jumousa.com



JUMO tecLine pH/Rd

pH and redox combination electrodes with ceramic or glass fiber diaphragm for wastewater, heavily polluted media, suspensions, varnishes

Typical areas of application

- Industrial wastewater engineering
- Process measurements, electroplating plants, paper industry, drinks industry
- Wastewater containing oil
- Suspensions, varnishes, media containing solid particles
- Two-chamber system for when electrode poisons are present
- Media containing fluorides (hydrofluoric acid) up to 1000 mg/l HF

Key features

- A dirt-repellent PTFE ring diaphragm with a highly viscous KCl solution (gel) or a perforated or annular-gap diaphragm with a polymerized solid electrolyte – virtually blockage-free
- Cartridge-style conduction system with a reference electrolyte with no silver ions
- Pressure-resistant versions up to 10 bar (50 °C)
- Temperature range: see order details
- Temperature probe integration options
- Salt reserve option for increasing service life in media with lower conductivity

JUMO GmbH & Co. KG
 Delivery address: Mackenrodtstraße 14
 36039 Fulda, Germany
 Postal address: 36035 Fulda, Germany
 Phone: +49 661 6003-0
 Fax: +49 661 6003-607
 E-mail: mail@jumo.net
 Internet: www.jumo.net

JUMO Instrument Co. Ltd.
 JUMO House
 Temple Bank, Riverway
 Harlow, Essex CM20 2DY, UK
 Phone: +44 1279 635533
 Fax: +44 1279 635262
 E-mail: sales@jumo.co.uk
 Internet: www.jumo.co.uk

JUMO Process Control, Inc.
 6733 Myers Road
 East Syracuse, NY 13057, USA
 Phone: 315-437-5866
 1-800-554-5866
 Fax: 315-437-5860
 E-mail: info.us@jumo.net
 Internet: www.jumousa.com



Dimensions

Type 201020/51

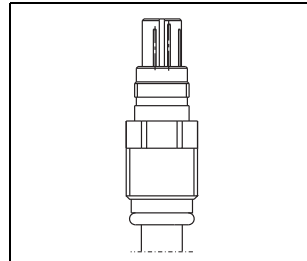
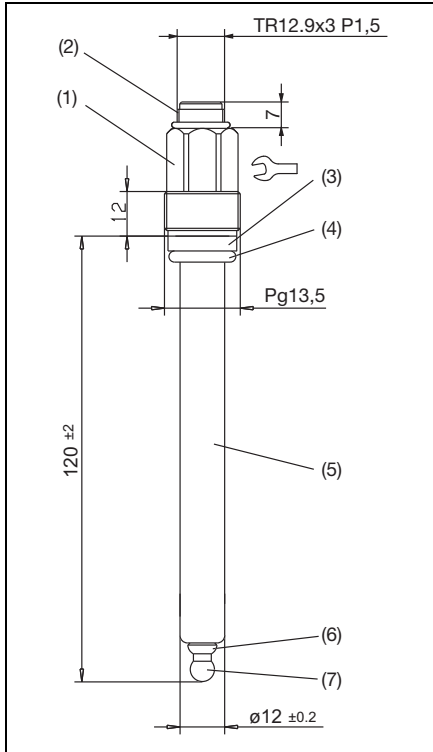

VP Pg13.5 screw cap

- (1) Pg13.5 screw cap
(max. tightening torque 3 Nm)
- (2) TR12.9 × 3 P1.5 thread
- (3) Ring (PSU)
- (4) O-ring 10 × 3,5 (FPM70)
- (5) Electrode shaft (DIN19263 glass)
- (6) Ring diaphragm (PTFE)
- (7) Rounded membrane

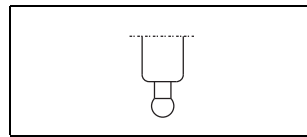

Annular-gap diaphragm

Type 201025/51

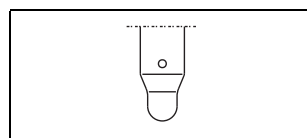
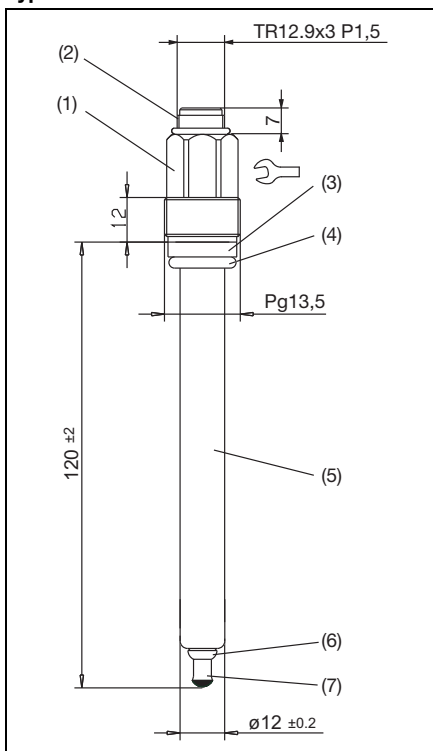

Perforated diaphragm

- (1) Pg13.5 screw cap
(max. tightening torque 3 Nm)
- (2) TR12.9 × 3 P1.5 thread
- (3) Ring (PSU)
- (4) O-ring 10 × 3,5 (FPM70)
- (5) Electrode shaft (DIN19263 glass)
- (6) Ring diaphragm (PTFE)
- (7) Platinum or gold tip

JUMO GmbH & Co. KG
 Delivery address: Mackenrodtstraße 14
 36039 Fulda, Germany
 Postal address: 36035 Fulda, Germany
 Phone: +49 661 6003-0
 Fax: +49 661 6003-607
 E-mail: mail@jumo.net
 Internet: www.jumo.net

JUMO Instrument Co. Ltd.
 JUMO House
 Temple Bank, Riverway
 Harlow, Essex CM20 2DY, UK
 Phone: +44 1279 635533
 Fax: +44 1279 635262
 E-mail: sales@jumo.co.uk
 Internet: www.jumo.co.uk

JUMO Process Control, Inc.
 6733 Myers Road
 East Syracuse, NY 13057, USA
 Phone: 315-437-5866
 1-800-554-5866
 Fax: 315-437-5860
 E-mail: info.us@jumo.net
 Internet: www.jumousa.com



Order details

	(1) Basic type	
	201020	JUMO tecLine pH - pH combination electrodes with ceramic or glass fiber diaphragm for wastewater, heavily polluted media, suspensions, varnishes
	201025	JUMO tecLine Rd - redox combination electrodes with ceramic or glass fiber diaphragm for wastewater, heavily polluted media, suspensions, varnishes
	(2) Basic type extension	
x x	51	Glass shaft, gel-sealed, cartridge-style conduction system
	(3) Active component	
x	18	UW glass, pH 0 - 12 (briefly 14), -5 to +80 °C
o	11	C glass, pH 0 - 12, -5 to +50 °C, fluoride-resistant up to 1000 mg HF/l
o	17	HA glass, pH 0 - 14, -5 to +80 °C, high-alkaline use
x	22	Platinum tip, redox range ±2000 mV, -5 to +90 °C
o	32	Gold tip, redox range ±2000 mV, -5 to +90 °C
	(4) Diaphragm	
x x	04	PTFE ring diaphragm
o o	10	Annular-gap diaphragm, gel of polymerized solid electrolyte ("diaphragm-free")
o o	11	Perforated diaphragm, gel of polymerized solid electrolyte ("diaphragm-free")
	(5) Connection	
o	18	VP Pg13.5 screw cap ^a
x x	22	Pg13.5 screw cap
	(6) Fitting length	
x x	120	120 mm (standard)
o o	225	225 mm
		Other lengths on request
	(7) Extra codes	
o o	000	None
x x	837	Salt reserve
o o	838	Two-chamber system (DOKA) with KCl/KCl bridge ^b
o	840	Pt100 temperature probe ^c
o	841	Pt1000 temperature probe ^c

^a For electrodes with extra code 840 or 841.

^b Not in conjunction with diaphragm 10 or 11.

^c With connection 18 only.

x = as standard

o = option

Order code (1) (2) (3) (4) (5) (6) (7) , ...^a
 / - - - - / , ...^a
Order example 201020 / 51 - 18 - 04 - 22 - 120 / 837

^a List extra codes in sequence, separated by commas.

Note:

The type code is not a modular system.

If possible, choose items listed under "**stock versions**" or "**production versions**" for your orders.

We will have to technically inspect and approve a free combination of individual key features.

JUMO GmbH & Co. KG

Delivery address: Mackenrodtstraße 14
36039 Fulda, Germany
Postal address: 36035 Fulda, Germany
Phone: +49 661 6003-0
Fax: +49 661 6003-607
E-mail: mail@jumo.net
Internet: www.jumo.net

JUMO Instrument Co. Ltd.

JUMO House
Temple Bank, Riverway
Harlow, Essex CM20 2DY, UK
Phone: +44 1279 635533
Fax: +44 1279 635262
E-mail: sales@jumo.co.uk
Internet: www.jumo.co.uk

JUMO Process Control, Inc.

6733 Myers Road
East Syracuse, NY 13057, USA
Phone: 315-437-5866
1-800-554-5866
Fax: 315-437-5860
E-mail: info.us@jumo.net
Internet: www.jumousa.com



pH stock versions

(delivery 3 working days after receipt of order)

Type	Brief description	Part no.
201020/51-18-04-22-120/000	Glass shaft, gel-sealed, PTFE diaphragm, Pg13.5 screw cap, 120 mm	00327907
201020/51-18-04-22-120/837	Glass shaft, gel-sealed, PTFE diaphragm, Pg13.5 screw cap, 120 mm, salt reserve	00321035
201020/51-18-04-22-225/837	Glass shaft, gel-sealed, PTFE diaphragm, Pg13.5 screw cap, 225 mm, salt reserve	00327142
201020/51-17-04-22-120/837	Glass shaft, gel-sealed, PTFE diaphragm, Pg13.5 screw cap, 120 mm (high-alkaline applications)	00332794
201020/51-18-04-18-120/837, 840	Glasschaft, gelsiegelt, PTFE diaphragm, VP Pg13.5 screw cap, 120 mm, salt reserve, integrated Pt100	00595188
201020/51-18-10-22-120/837	Glasschaft, gelsiegelt, annular-gap diaphragm, Pg13.5 screw cap 120 mm, salt reserve	00446112

pH production versions

(delivery 10 working days after receipt of order)

Type	Brief description	Part no.
201020/51-18-04-17-120/840	Glass shaft, gel-sealed, PTFE diaphragm, VP Pg13.5 screw cap, 120 mm, integrated Pt100	00383865
201020/51-18-04-22-225/000	Glass shaft, gel-sealed, PTFE diaphragm, Pg13.5 screw cap, 225 mm	00372505
201020/51-18-11-22-120/837	Glass shaft, gel-sealed, perforated diaphragm and solid electrolyte, screw cap, 120 mm, salt reserve	00445428
201020/51-18-11-18-120/837, 840	Glass shaft, gel-sealed, perforated diaphragm and solid electrolyte, VP screw cap, 120 mm, salt reserve, integrated Pt100	00516974

Redox stock versions

(delivery 3 working days after receipt of order)

Type	Brief description	Part no.
201025/51-22-04-22-120/837	Glass shaft, gel-sealed, platinum tip, PTFE diaphragm, Pg13.5 screw cap, 120 mm, salt reserve	00321746

JUMO GmbH & Co. KG

Delivery address: Mackenrodtstraße 14
36039 Fulda, Germany
Postal address: 36035 Fulda, Germany
Phone: +49 661 6003-0
Fax: +49 661 6003-607
E-mail: mail@jumo.net
Internet: www.jumo.net

JUMO Instrument Co. Ltd.

JUMO House
Temple Bank, Riverway
Harlow, Essex CM20 2DY, UK
Phone: +44 1279 635533
Fax: +44 1279 635262
E-mail: sales@jumo.co.uk
Internet: www.jumo.co.uk

JUMO Process Control, Inc.

6733 Myers Road
East Syracuse, NY 13057, USA
Phone: 315-437-5866
1-800-554-5866
Fax: 315-437-5860
E-mail: info.us@jumo.net
Internet: www.jumousa.com



JUMO tecLine pH/Rd

pH and redox combination electrodes for high-temperature and sterilization applications

Typical areas of application

- Processes with permanently elevated temperatures (max. 135 °C)
- Sterilization applications
- Two-chamber system for when electrode poisons are present
- Media containing fluorides (hydrofluoric acid) up to 1000 mg HF/l

Key features

- Proven JUMO HT glass (pH high-temperature membrane glass) 0 - 14 pH
- JUMO DS membrane glass for sterilization applications
- Cartridge-style conduction system with a (gel) reference electrolyte with no silver ions
- Pressure-resistant versions up to 10 bar (50 °C)
- Temperature range: 0 to 135 °C¹
- Temperature probe integration options
- Redox versions with a platinum or gold tip up to ±2000 mV

¹ Sterilizable version: sterilization at max. 135 °C for up to 20 minutes. Continuous electrode operation after sterilization up to max. 80 °C.

JUMO GmbH & Co. KG
 Delivery address: Mackenrodtstraße 14
 36039 Fulda, Germany
 Postal address: 36035 Fulda, Germany
 Phone: +49 661 6003-0
 Fax: +49 661 6003-607
 E-mail: mail@jumo.net
 Internet: www.jumo.net

JUMO Instrument Co. Ltd.
 JUMO House
 Temple Bank, Riverway
 Harlow, Essex CM20 2DY, UK
 Phone: +44 1279 635533
 Fax: +44 1279 635262
 E-mail: sales@jumo.co.uk
 Internet: www.jumo.co.uk

JUMO Process Control, Inc.
 6733 Myers Road
 East Syracuse, NY 13057, USA
 Phone: 315-437-5866
 1-800-554-5866
 Fax: 315-437-5860
 E-mail: info.us@jumo.net
 Internet: www.jumousa.com



Dimensions

Type 20102x/75

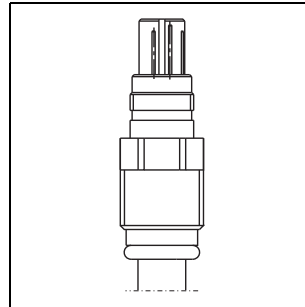
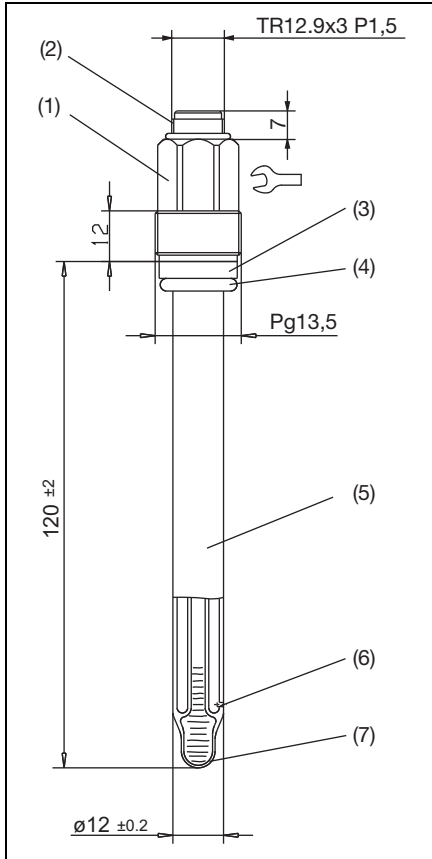

VP Pg13.5 screw cap

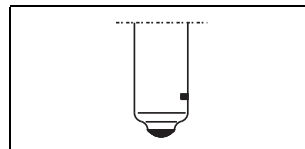

Platinum or gold tip
type 201025/...

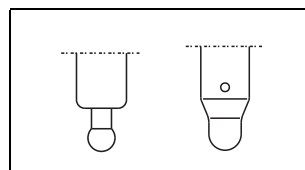

Annular-gap/perforated
diaphragm

- (1) Pg13.5 screw cap
(max. tightening torque 3 Nm)
- (2) TR12.9 × 3 P1.5 thread
- (3) Ring (PSU)
- (4) O-ring 10 × 3,5 (FPM70)
- (5) Electrode shaft (DIN 19263 glass)
- (6) 1 to 3 diaphragms
(zirconium dioxide Ø 1 mm)
- (7) Rounded membrane

JUMO GmbH & Co. KG
 Delivery address: Mackenrodtstraße 14
 36039 Fulda, Germany
 Postal address: 36035 Fulda, Germany
 Phone: +49 661 6003-0
 Fax: +49 661 6003-607
 E-mail: mail@jumo.net
 Internet: www.jumo.net

JUMO Instrument Co. Ltd.
 JUMO House
 Temple Bank, Riverway
 Harlow, Essex CM20 2DY, UK
 Phone: +44 1279 635533
 Fax: +44 1279 635262
 E-mail: sales@jumo.co.uk
 Internet: www.jumo.co.uk

JUMO Process Control, Inc.
 6733 Myers Road
 East Syracuse, NY 13057, USA
 Phone: 315-437-5866
 1-800-554-5866
 Fax: 315-437-5860
 E-mail: info.us@jumo.net
 Internet: www.jumousa.com



Order details

	(1) Basic type	
	201020	JUMO tecLine pH - pH combination electrodes with ceramic or glass fiber diaphragm for high-temperature and sterilization applications
	201025	JUMO tecLine Rd - redox combination electrodes with ceramic or glass fiber diaphragm for high-temperature and sterilization applications
	(2) Basic type extension	
x x	75	Glass shaft, high-temperature gel, sealed, cartridge-style conduction system
	(3) Active component	
x	12	HT glass, pH 0 - 14, -5 to +135 °C
o	14	DS glass, pH 0 - 14, -5 to +80 °C, can be sterilized for 20 minutes at 135 °C
x	22	Platinum tip, redox range ±2000 mV, -5 to +135 °C
o	32	Gold tip, redox range ±2000 mV, -5 to +135 °C
	(4) Diaphragm	
x x	07	1× zirkonium dioxide diaphragm (special ceramic)
o o	09	3× zirkonium dioxide diaphragm (special ceramic)
o o	10	Annular-gap diaphragm, gel of polymerized solid electrolyte ("diaphragm-free" ^a)
o o	11	Perforated diaphragm, gel of polymerized solid electrolyte ("diaphragm-free" ^a)
	(5) Connection	
o	18	VP Pg13.5 screw cap ^a
x x	22	Pg13.5 screw cap
	(6) Fitting length	
x x	120	120 mm (standard)
o o	225	225 mm
		Other length on request
	(7) Extra codes	
o o	000	None
x x	837	Salt reserve ^b
o	840	Pt100 temperature probe ^c
o	841	Pt1000 temperature probe ^c

^a For electrodes with extra code 840 or 841.
^b Only in conjunction with diaphragma 10 and 11.
^c With connection 18 only.

x = serienmäßig
 o = optional

Bestellschlüssel	(1)	(2)	(3)	(4)	(5)	(6)	(7)						
Bestellbeispiel	201020	/	75	-	12	-	07	-	22	-	120	/	000

Note:
 The type code is not a modular system.
 If possible, choose items listed under "**stock versions**" or "**production versions**" for your orders.
 We will have to technically inspect and approve a free combination of individual key features.

pH stock versions

(delivery 3 working days after receipt of order)

Type	Brief description	Part no.
201020/75-12-07-22-120/000	Glass shaft, gel-sealed, HT gel, zirconium dioxide diaphragm, Pg13.5 screw cap, 120 mm (high-temperature applications)	00304030

pH production versions

(delivery 10 working days after receipt of order)

Type	Brief description	Part no.
201020/75-12-11-18-120/837, 840	Glass shaft, gel-sealed, solid electrolyte, perforated diaphragm, VP Pg13.5 screw cap, 120 mm (high-temperature applications)	00542508

JUMO GmbH & Co. KG

Delivery address: Mackenrodtstraße 14
36039 Fulda, Germany
Postal address: 36035 Fulda, Germany
Phone: +49 661 6003-0
Fax: +49 661 6003-607
E-mail: mail@jumo.net
Internet: www.jumo.net

JUMO Instrument Co. Ltd.

JUMO House
Temple Bank, Riverway
Harlow, Essex CM20 2DY, UK
Phone: +44 1279 635533
Fax: +44 1279 635262
E-mail: sales@jumo.co.uk
Internet: www.jumo.co.uk

JUMO Process Control, Inc.

6733 Myers Road
East Syracuse, NY 13057, USA
Phone: 315-437-5866
1-800-554-5866
Fax: 315-437-5860
E-mail: info.us@jumo.net
Internet: www.jumousa.com



JUMO tecLine pH/Rd

pH and redox combination electrodes with liquid KCl filling, refillable

Typical areas of application

- Low-ion media with conductivity < 100 µS/cm (recommended)
- Ultra-pure water applications
- Electroplating processes, PCB production
- Fermenters
- Heavily polluted, adherent media
- Suspensions, varnishes
- Boiler feed water

Key features

- Can be combined with all JUMO membrane glasses
- Zirconium dioxide diaphragm
- Cartridge-style conduction system Refillable, KCl solution with no silver ions
- Temperature range: -10 to +135 °C¹
- Redox versions with platinum or gold tip ± 2000 mV

Construction of an electrolyte bridge

In the case of pH and redox measurement, there are several disruptive factors that can reduce the accuracy or the service life of the measurement electrode. If the medium disrupts, pollutes or chemically attacks the measurement electrode, the only possible remedies are to use selected measurement electrodes, to treat the samples, or to use an electrolyte bridge.

Disruptive factors can include:

- Getting oiled-up, blocked-up
Diaphragm is blocked because of precipitation or coating buildup, for example
- Poisoning
Chemical reaction of reference system with medium
- Pressure fluctuations
Medium penetrates the electrode

When using an electrolyte bridge, the reference electrode is removed from the medium and installed in a separate vessel somewhere safe. The use of an electrolyte bridge in tubing (flow-through) and in a container, is shown on the next page.

¹ Depending on the type of glass

Construction of an electrolyte bridge für combination electrodes with liquid KCl supply

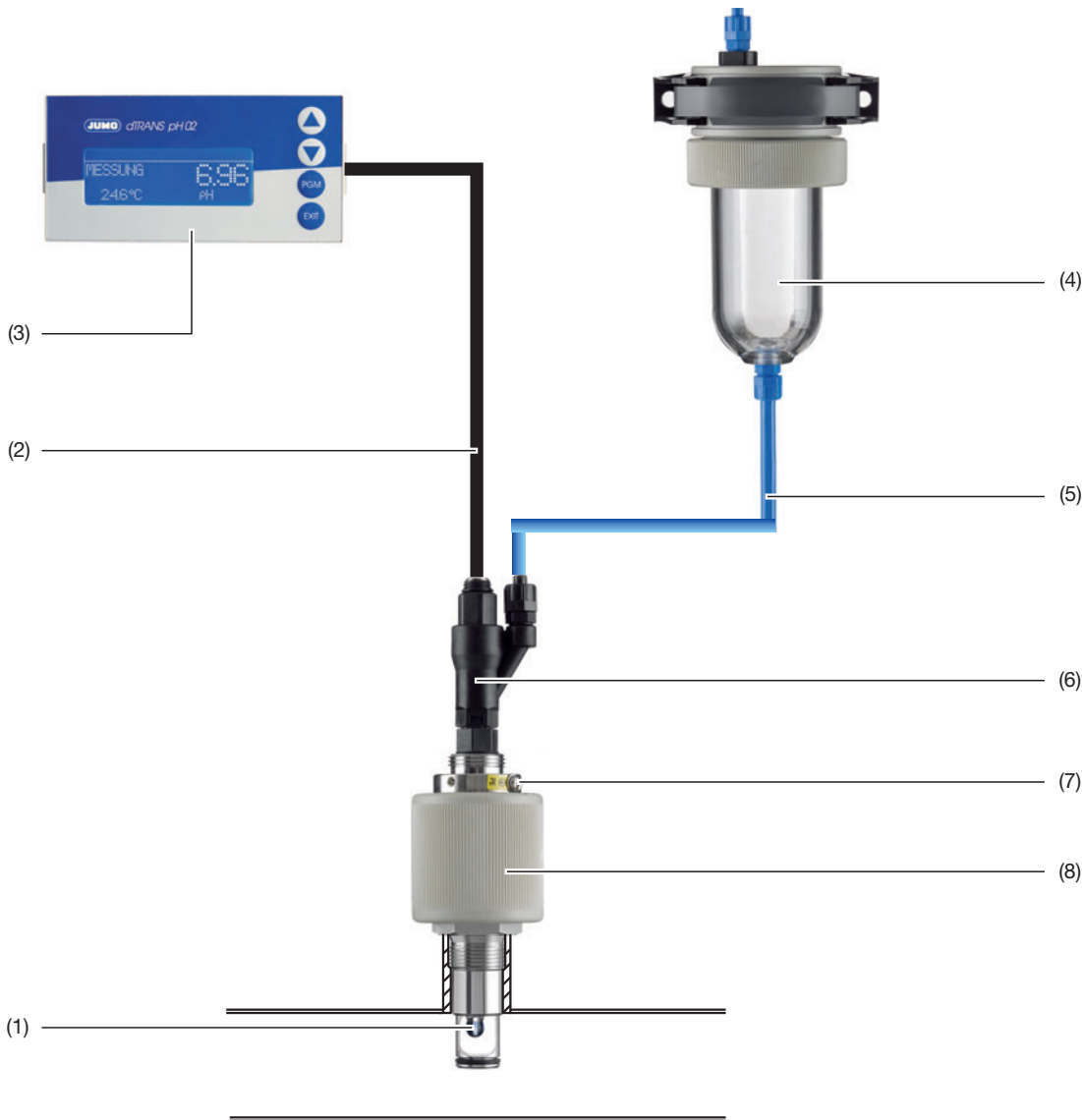

- (1) pH combination electrode with KCl liquid electrolyte, e.g. 201020/76-18-09-22-180/833, part no. 00373964
- (2) Electrode connecting cable, e.g. 202990/02-92-5-13, part no. 00307298
- (3) Transmitter JUMO dTRANS pH 02, e.g. 202551/01-8-01-4-0-00-23/000, part no. 00560379
- (4) KCl storage vessel, pressure-resistant, for wall mounting, part no. 00060254
- (5) Hose coupling from diaphragm tube to KCl storage vessel (included in 4)
- (6) KCl connection (accessorie for 1), part no. 00475617
- (7) Grounding
- (8) Quick-change fittings, e.g. 202822/105-062-26, part no. 00366915

JUMO GmbH & Co. KG
 Delivery address: Mackenrodtstraße 14
 36039 Fulda, Germany
 Postal address: 36035 Fulda, Germany
 Phone: +49 661 6003-0
 Fax: +49 661 6003-607
 E-mail: mail@jumo.net
 Internet: www.jumo.net

JUMO Instrument Co. Ltd.
 JUMO House
 Temple Bank, Riverway
 Harlow, Essex CM20 2DY, UK
 Phone: +44 1279 635533
 Fax: +44 1279 635262
 E-mail: sales@jumo.co.uk
 Internet: www.jumo.co.uk

JUMO Process Control, Inc.
 6733 Myers Road
 East Syracuse, NY 13057, USA
 Phone: 315-437-5866
 1-800-554-5866
 Fax: 315-437-5860
 E-mail: info.us@jumo.net
 Internet: www.jumousa.com



Dimensions

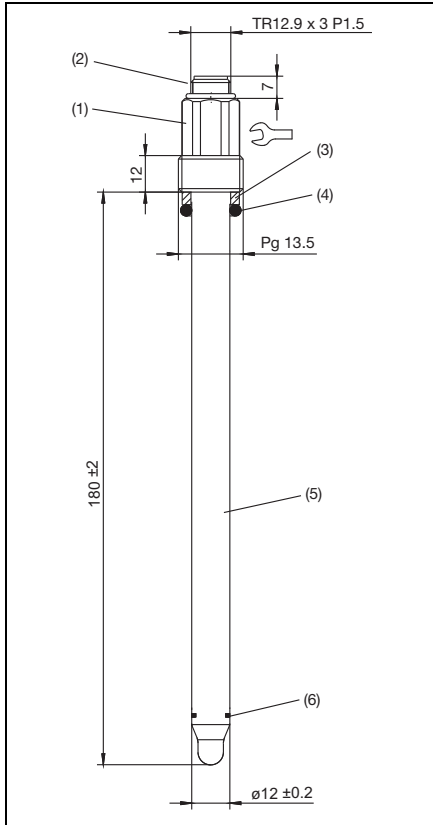

Electrode type 201020/76-...
 Fitting length 180 mm
 Zirconium dioxide diaphragm
 (diaphragm 09)

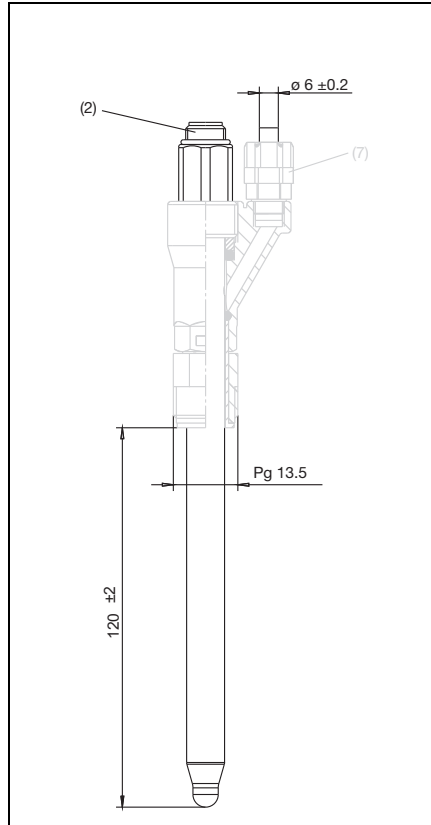

Electrode type 201020/76-...-...-.../833
 Fitting length 120 mm
 Applicable for KCl connection

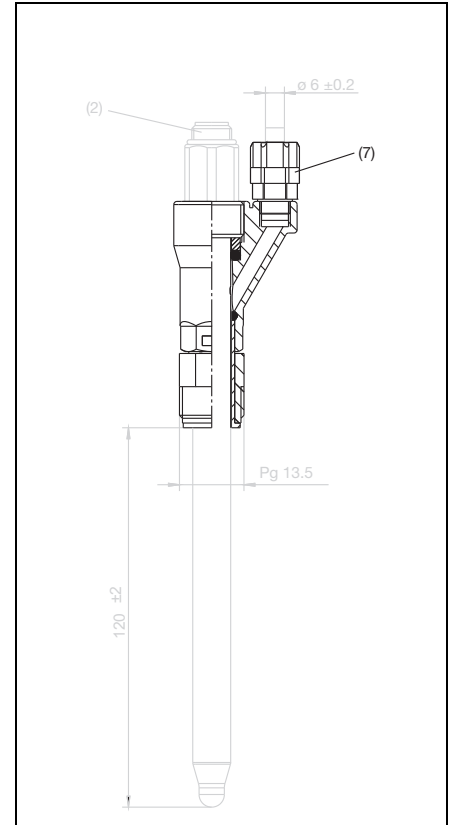

KCl connection for electrode type 201020/76-...-...-.../833
 (ordered as accessories, part no. 00475617)
 Material: PPO (polyphenylene oxide)
 Temperature range: 0 to 105 °C,
 briefly +130 °C
 Pressure range: max. 10 bar (25 °C)

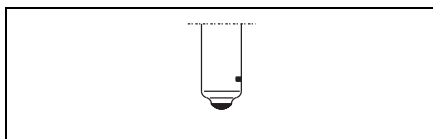

Platinum or gold tip type 201025/...

- | | |
|--|-----------------------------|
| (1) Pg13.5 screw cap (max. tightening torque 3 Nm) | (2) TR12.9 x 3 P1.5 thread |
| (3) Ring (PSU) | (4) O-ring 10 x 3,5 (FPM70) |
| (5) Electrode shaft (DIN19263 glass) | (6) 1 to 3 diaphragms |
| (7) Connection for overpressure attachment | |

JUMO GmbH & Co. KG
 Delivery address: Mackenrodtstraße 14
 36039 Fulda, Germany
 Postal address: 36035 Fulda, Germany
 Phone: +49 661 6003-0
 Fax: +49 661 6003-607
 E-mail: mail@jumo.net
 Internet: www.jumo.net

JUMO Instrument Co. Ltd.
 JUMO House
 Temple Bank, Riverway
 Harlow, Essex CM20 2DY, UK
 Phone: +44 1279 635533
 Fax: +44 1279 635262
 E-mail: sales@jumo.co.uk
 Internet: www.jumo.co.uk

JUMO Process Control, Inc.
 6733 Myers Road
 East Syracuse, NY 13057, USA
 Phone: 315-437-5866
 1-800-554-5866
 Fax: 315-437-5860
 E-mail: info.us@jumo.net
 Internet: www.jumousa.com



Order details

	(1) Basic type	
	201020	JUMO tecLine pH - pH combination electrodes with liquid KCl filling, refillable
	201025	JUMO tecLine Rd - redox combination electrodes with liquid KCl filling, refillable
	(2) Basic type extension	
x x	76	Glass shaft, KCl liquid electrolyte, cartridge-style conduction system
	(3) Active component	
x	18	UW glass, pH 0 - 12 (briefly 14), -5 to +80 °C
o	11	C glass, pH 0 - 12, -5 to +50 °C
o	12	HT glass, pH 0 - 14, 0 to 135 °C (also for high-alkaline use)
o	14	DS glass, pH 0 - 12, 0 to 80 °C (can be sterilized for 20 minutes at 135 °C)
x	22	Platinum tip, redox range ±2000 mV, -5 to +90 °C
o	32	Gold tip, redox range ±2000 mV, -5 to +90 °C
	(4) Diaphragm	
x x	07	1× zirconium dioxide diaphragm (special ceramic)
o o	09	3× zirconium dioxide diaphragm (special ceramic)
	(5) Connection	
x x	22	Pg13.5 screw cap
	(6) Fitting length	
o o	120	120 mm (standard)
x x	180	Effective fitting length 120mm, but glass length 180mm ^a
	(7) Extra code	
o o	000	None
x	833	Applicable for KCl connection ^b

^a Only in conjunction with extra code 833.

^b Only in conjunction with fitting length 180 mm.

x = as standard
 o = option

	(1)	(2)	(3)	(4)	(5)	(6)	(7)
Order code	<input type="text"/>	/	<input type="text"/>	-	<input type="text"/>	-	<input type="text"/>
Order example	201020	/	76	-	18	-	07
				-	22	-	120
						/	000

Note:

The type code is not a modular system.

If possible, choose items listed under "**stock versions**" or "**production versions**" for your orders.

We will have to technically inspect and approve a free combination of individual key features.

JUMO GmbH & Co. KG

Delivery address: Mackenrodtstraße 14
36039 Fulda, Germany
Postal address: 36035 Fulda, Germany
Phone: +49 661 6003-0
Fax: +49 661 6003-607
E-mail: mail@jumo.net
Internet: www.jumo.net

JUMO Instrument Co. Ltd.

JUMO House
Temple Bank, Riverway
Harlow, Essex CM20 2DY, UK
Phone: +44 1279 635533
Fax: +44 1279 635262
E-mail: sales@jumo.co.uk
Internet: www.jumo.co.uk

JUMO Process Control, Inc.

6733 Myers Road
East Syracuse, NY 13057, USA
Phone: 315-437-5866
1-800-554-5866
Fax: 315-437-5860
E-mail: info.us@jumo.net
Internet: www.jumousa.com



pH production versions

(delivery 10 working days after receipt of order)

Type	Brief description	Part no.
201020/76-18-09-22-180/833	Glass shaft, KCl liquid electrolyte, 3× zirconium dioxide diaphragm, fitting length 180 mm	00373964
201020/76-12-07-20-120/000	Glass shaft, KCl liquid electrolyte, zirconium dioxide diaphragm, hose olive with Pg13.5 threaded coupling cemented with putty, 120 mm	00300160

Redox production versions

(delivery 10 working days after receipt of order)

Type	Brief description	Part no.
201025/76-22-07-22-180/833	Glass shaft, KCl liquid electrolyte, 1× zirconium dioxide diaphragm, fitting length 180 mm	00303849

Accessories

Type	Part no.
KCl connection (PG 209791)	00475617
KCl storage vessel, pressure-resistant, for wall mounting for construction an electrolyte bridge or when using electrodes filled with KCl (PG 209791)	00060254
3-molar KCl solution, 5 × 250 ml pack unit (also see data sheet 201090) (PG 202950)	00306215

JUMO GmbH & Co. KG

Delivery address: Mackenrodtstraße 14
36039 Fulda, Germany
Postal address: 36035 Fulda, Germany
Phone: +49 661 6003-0
Fax: +49 661 6003-607
E-mail: mail@jumo.net
Internet: www.jumo.net

JUMO Instrument Co. Ltd.

JUMO House
Temple Bank, Riverway
Harlow, Essex CM20 2DY, UK
Phone: +44 1279 635533
Fax: +44 1279 635262
E-mail: sales@jumo.co.uk
Internet: www.jumo.co.uk

JUMO Process Control, Inc.

6733 Myers Road
East Syracuse, NY 13057, USA
Phone: 315-437-5866
1-800-554-5866
Fax: 315-437-5860
E-mail: info.us@jumo.net
Internet: www.jumousa.com



JUMO tecLine PRO pH/Rd

pH and redox combination electrodes

201020 series - pH electrodes

201025 series - redox electrodes

(previous designation 2 GE-20-...)

General description

The electrodes of the 201020(25)/79 series are known for their high mechanical and chemical resistance. Thanks to their sturdy PVDF body, there is hardly any risk of the sensor breaking. The electrolyte of these combination electrodes guarantees a stable measurement value, even in critical media containing sulphides.

There is an integrated Pt1000 temperature probe. The electrodes can be manufactured as pH or redox electrodes, subject to the application. An open annular-gap diaphragm is the type of diaphragm used.

Areas of operation

- Chemical industry
- Wastewater treatment
- Sewage treatment works
- Paper industry



JUMO GmbH & Co. KG
 Delivery address: Mackenrodtstraße 14
 36039 Fulda, Germany
 Postal address: 36035 Fulda, Germany
 Phone: +49 661 6003-0
 Fax: +49 661 6003-607
 E-mail: mail@jumo.net
 Internet: www.jumo.net

JUMO Instrument Co. Ltd.
 JUMO House
 Temple Bank, Riverway
 Harlow, Essex CM20 2DY, UK
 Phone: +44 1279 635533
 Fax: +44 1279 635262
 E-mail: sales@jumo.co.uk
 Internet: www.jumo.co.uk

JUMO Process Control, Inc.
 6733 Myers Road
 East Syracuse, NY 13057, USA
 Phone: 315-437-5866
 1-800-554-5866
 Fax: 315-437-5860
 E-mail: info.us@jumo.net
 Internet: www.jumousa.com



Dimensions

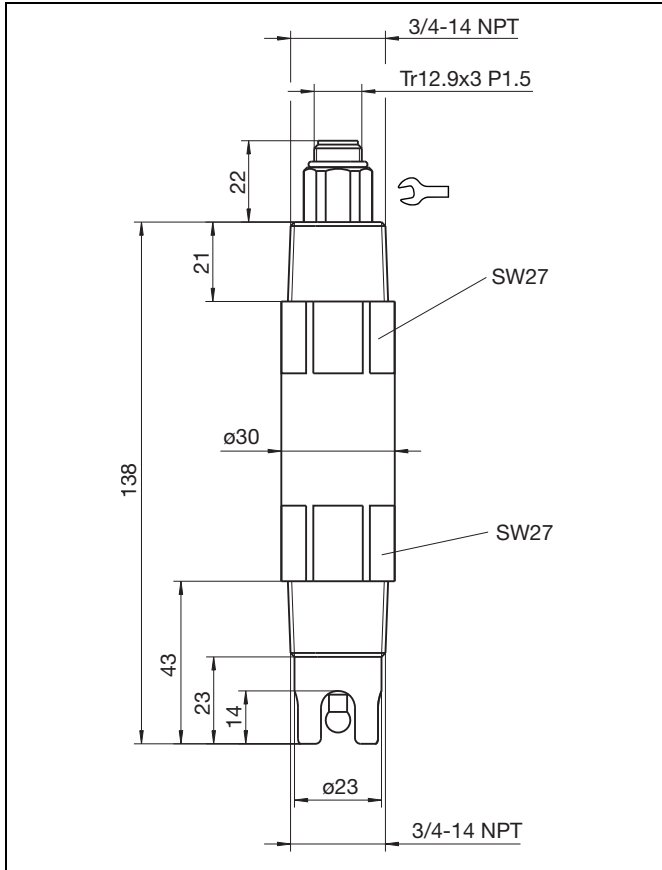

Type 201020/...

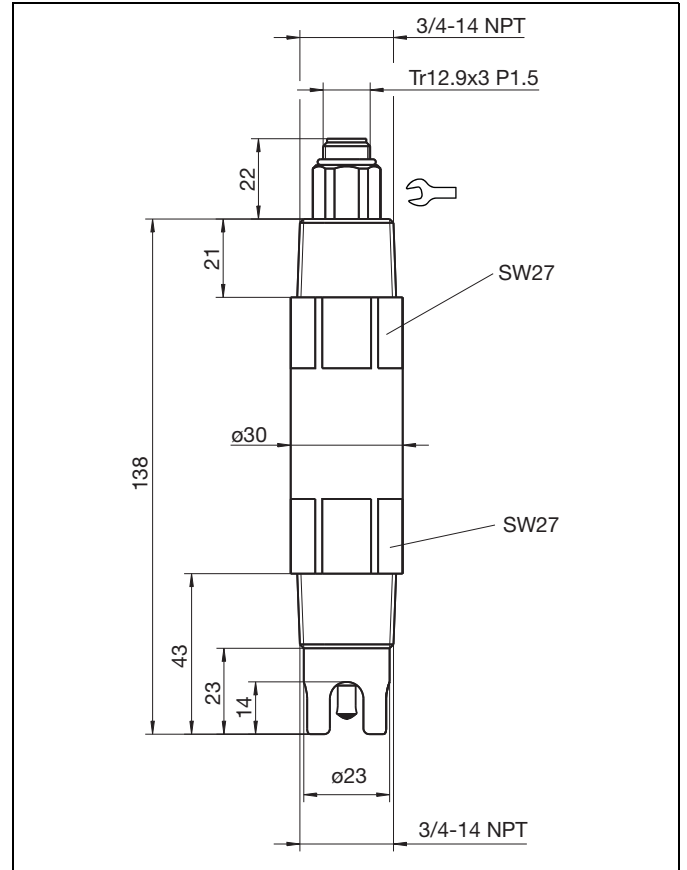

Type 201025/...

JUMO GmbH & Co. KG
 Delivery address: Mackenrodtstraße 14
 36039 Fulda, Germany
 Postal address: 36035 Fulda, Germany
 Phone: +49 661 6003-0
 Fax: +49 661 6003-607
 E-mail: mail@jumo.net
 Internet: www.jumo.net

JUMO Instrument Co. Ltd.
 JUMO House
 Temple Bank, Riverway
 Harlow, Essex CM20 2DY, UK
 Phone: +44 1279 635533
 Fax: +44 1279 635262
 E-mail: sales@jumo.co.uk
 Internet: www.jumo.co.uk

JUMO Process Control, Inc.
 6733 Myers Road
 East Syracuse, NY 13057, USA
 Phone: 315-437-5866
 1-800-554-5866
 Fax: 315-437-5860
 E-mail: info.us@jumo.net
 Internet: www.jumousa.com



Order details

	(1) Basic type	
	201020	JUMO tecLine PRO pH - pH combination electrodes
	201025	JUMO tecLine PRO Redox - redox combination electrodes
	(2) Basic type extension	
x x	79	Process electrode
	(3) Active component	
	12	HT glass, 0 to 110 °C; pH 0 - 14
x	18	UW glass, -5 to +80°C; pH 0 - 12 (briefly pH 14)
o x	22	Platinum tip, 0 to 110 °C; ±2000 mV
o	32	Gold tip, 0 to 110 °C; ±2000 mV
	(4) Diaphragm	
x x	10	Annular-gap diaphragm; gel of polymerized solid electrolyte ("diaphragm-free")
	(5) Electrical connection	
o o	18	VP Pg13.5 screw cap
x x	22	Screw cap
	(6) Extra code	
x x	837	Salt reserve
o	841	Integrated Pt1000

x = as standard
 o = option

	(1)	(2)	(3)	(4)	(5)	(6)	(7)
Order code	<input type="text"/>	<input type="text"/>	<input type="text"/>	<input type="text"/>	<input type="text"/>	<input type="text"/>	<input type="text"/>
Order example	201020	/	79	-	12	-	10 - 22 - 43 / 841

Note:

The type code is not a modular system.
 If possible, choose items listed under "**stock versions**" or "**production versions**" for your orders.
 We will have to technically inspect and approve a free combination of individual key features.

pH production versions

(delivery 10 working days after receipt of order)

Type	Brief description	Part no.
201020/79-18-10-22/837	UW glass, screw cap, solid electrolyte, annular-gap diaphragm, salt reserve	00468999
201020/79-12-10-22/837	HT glass, screw cap, solid electrolyte, annular-gap diaphragm, salt reserve	00469853

Accessories

Type	Part no.
Connecting cable VP screw cap, 5 m, type 202990/11-95-5-11	00372919
Connecting cable VP screw cap, 10 m, type 202990/11-95-10-11	00373029