

IN-uP4 (Rev 1)

Universal Input Indicator, Panel Mount.



Installation Guide.

IN-uP4 Installation Guide Index.

Description.	Page 3
Features.	Page 3
Ordering Information.	Page 3
Product Liability.	Page 3
Specifications.	Page 4
IN-uP4 Dimensions & Terminal Layout.	Page 6
<i>Front Panel Layout.</i>	Page 6
<i>Back Panel Layout.</i>	Page 6
<i>Front Indicator Dimensions.</i>	Page 6
<i>Side Dimensions.</i>	Page 6
<i>Top Panel Dimensions.</i>	Page 7
Installing uP Configure.	Page 7
Connecting the XU-USB Key.	Page 9
<i>Connecting uP Configure to the IN-uP4.</i>	Page 9
Using the uP Configure Software Configuration.	Page 9
uP Configure Interface Overview.	Page 10
Input & Output Connection Diagrams.	Page 11
<i>Voltage Input.</i>	Page 11
<i>Current Input.</i>	Page 12
<i>Sensor Power Supply.</i>	Page 12
<i>Thermocouple Input.</i>	Page 13
<i>RTD Input.</i>	Page 13
<i>NTC Input.</i>	Page 13
<i>Pulse & Frequency Input.</i>	Page 13
<i>Potentiometer Input.</i>	Page 14
<i>Analogue Output - IN-uP4X only.</i>	Page 14
<i>Relay Outputs - IN-uP4X only.</i>	Page 14
<i>Power Supply.</i>	Page 15
IN-uP4 Wiring, Installation and Maintenance.	Page 15
<i>IN-uP4 Wiring and Installation.</i>	Page 15
<i>Mounting.</i>	Page 15
<i>Analogue Signal Wiring.</i>	Page 15
<i>Thermocouple Extension Wire.</i>	Page 15
<i>Thermocouples.</i>	Page 15
<i>RTDs.</i>	Page 16
<i>Power Supply Wiring.</i>	Page 16
<i>IN-uP4 Commissioning.</i>	Page 16
<i>IN-uP4 Maintenance.</i>	Page 16

Description.

The IN-uP4 (Rev 1) is a panel mount, universal single input indicator, which makes interface with a wide range of sensors easy. The IN-uP4 has a 4-digit LED display. An option to add two relay outputs (with two setpoint indicator LEDs), and one 4~20mA analogue output is available. The indicator has a Universal Power Supply of 24~250Vac / 19.5~250Vdc.

Setup and calibration is simple, using 'uP Configure' software, with step-by-step instructions.



Features.

- Universal Input with Indication.
- Panel Mount.
- Programmable via USB Port using **uP Configure** software and the **XU-USB** (Rev 1) key.
- Simple setup and calibration.
- 4-digit LED Display.
- Option to add Two Relay Outputs (with two setpoint indicator LEDs), and One 4~20mA Analogue Output.
- Wide Range of Power Supply options.
- Sensor Power Supply for powering external Transmitter.
- IP65.
- Low Cost.

Ordering Information.

CODE	DESCRIPTION
IN-uP4	Universal Input Indicator with No Outputs.
IN-uP4X	Universal Input Indicator with Two Relay Outputs plus One 4~20mA Analogue Output.

Universal Power Supply of 24~250Vac / 19.5~250Vdc.

Note: The IN-uP4 Universal Input Indicator is pre-programmed for RTD Pt100 input as standard.

To program the IN-uP4 requires the XU-USB (Rev 1) Programming Key:

XU-USB (Rev 1)	USB Programming Key for programming IN-uP4 using uP Configure Programming software. Note: XU-USB must be (Rev 1) or later! Older versions will NOT connect with the IN-uP4. (Same Key as used for programming XU Series transmitters, 2400-A16 / 2400-M-R, Z-2400-Sleeper, Z-2400-A2 Series and uP4-Din.)
-----------------------	--



Product Liability. This information describes our products. It does not constitute guaranteed properties and is not intended to affirm the suitability of a product for a particular application. Due to ongoing research and development, designs, specifications, and documentation are subject to change without notification. Regrettably, omissions and exceptions cannot be completely ruled out. No liability will be accepted for errors, omissions or amendments to this specification. Technical data are always specified by their average values and are based on Standard Calibration Units at 25C, unless otherwise specified. Each product is subject to the 'Conditions of Sale'.

Warning: These products are not designed for use in, and should not be used for patient connected applications. In any critical installation an independent fail-safe back-up system must always be implemented.

Specifications.

Input Specifications:

Excitation - Sensor Power Supply +22Vdc \pm 10%, 25mA max.

Accuracy/Repeatability 0.05% of FSO.

Temperature Drift 30ppm/ $^{\circ}$ C typical.

Voltage Input Specifications:

mV Range -200mV~200mV.

V Range 0~1V, 0~10V, -10~30V, 0~300V.

Minimum Input resistance 1M Ω .

Linearity and Repeatability $<\pm$ 0.02% FSO typical.

Response Time 100msec.

USB Programmable Zero 0~ \pm 99% of the Span.

USB Programmable Span 95% of FSO.

Current Input Specifications:

mA Range 0~20mA (4~20mA).

Input Resistance 10 Ω .

Maximum Over-range 50mAdc Continuous.

Linearity and Repeatability $<\pm$ 0.02% FSO typical.

Response Time 100msec.

USB Programmable Zero 0~ \pm 99% of the Span.

USB Programmable Span 1 μ A~24mAdc.

Thermocouple Input Specifications:

Thermocouple Types B, E, J, K, N, R, S, T.

Input Impedance 1M Ω Minimum.

T/C Lead Resistance 100 Ω Maximum.

Cold Junction Compensation -10~70 $^{\circ}$ C.

Accuracy E, J, K, N, T $<\pm$ 1 $^{\circ}$ C.

B, R, S $<\pm$ 2 $^{\circ}$ C.

Temperature Drift E, J, K, N, T $<\pm$ 0.05 $^{\circ}$ C.

B, R, S $<\pm$ 0.2 $^{\circ}$ C.

CJC Error $<\pm$ 1 $^{\circ}$ C.

Sensor Fail Upscale or Downscale Selectable (Upscale Default).

Response Time 400msec.

USB Programmable Zero 0~ \pm 99% of the Span.

USB Programmable Span Within Thermocouple Type limits.

RTD Input Specifications:

RTD Input Pt100 or Pt1000 DIN 3-wire Type.
(2-wire can be used with offset calibration.)

Sensor Current 0.3mA Nominal.

Lead Wire Resistance Pt100: 10 Ω /wire Maximum.

Pt1000: 5 Ω /wire Maximum.

0.02% FSO Offset Error per Ω of Lead Resistance.

Sensor Fail Upscale or Downscale Selectable (Upscale Default).

Linearity (Pt100) 0.02% FSO for Span Inputs \leq 200 $^{\circ}$ C. 0.1% FSO for Span Inputs \leq 300 $^{\circ}$ C.

Linearity (Pt1000) 0.02% FSO for Span Inputs \leq 200 $^{\circ}$ C. 0.2% FSO for Span Inputs \leq 300 $^{\circ}$ C.

Response Time 400msec.

USB Programmable Zero 0~ \pm 99% of the Span.

USB Programmable Span Within Thermocouple Type limits.

NTC Thermistor Input Specifications:

NTC Sensor Types 10K (Beta 3984) -55~125 $^{\circ}$ C.

10K (Beta 3435) -50~110 $^{\circ}$ C.

Response Time 100msec.

Pulse & Frequency Input Specifications:

Input Type	Open Contact - NPN, PNP.
Frequency Range	0~2000Hz.
Response Time	100msec.
Software Modes	General Frequency, Flow Rate or RPM.

Potentiometer Input Specifications:

Potentiometer input	3-wire.
Excitation voltage	Variable.
Potentiometer resistance	<1kΩ low pot; 1~4kΩ med pot; 4~20kΩ high pot.
Field programmable zero	0~90% of span.
Field programmable span	0.1~100%.
Linearity and repeatability	<±0.05% FSO typical.
Response time	100msec.

Output Specifications: IN-uP4X only.

Analogue Output:	Isolated.
mA Range	4~20mA or 20~4mA.
Resolution	1μA.
Output Drive	600Ω at 12Vdc.

Relay Outputs:	2 Isolated Relays with LED indication on each output.
Functions	2 on Board Controllers can be used as Set Point (SV), Switching Differential, Auto/Manual, Manual Output Setting, Dual Action Control, Single Action Control, Heat/Cool, Cool Only, Heat Only.
Relay Ratings	250Vac, 3A Max.

General Specifications:

Power Supply:	24~250Vac / 19.5~250Vdc (47-63Hz, 6VA max).
----------------------	---

Safety Compliance:

EMC Emissions	EN 61326.
EMC Immunity	EN 61326.
Safety	EN 61010-1.

General Specifications:

Accurate to	<±0.03% FSO typical.
Ambient drift	<±0.003%/°C FSO typical.
EMC Influence	<0.2% of full scale range.
Noise Immunity	125dB CMRR average (2.0KVdc limit).
Operating Humidity	5~85%RH max (non-condensing).
Operating Temperature	-10~50°C.
Storage Temperature	-20~60°C.
Indicator Housing:	IP65.
Indicator Case Dimensions	H=48, W=95, D=62mm. Allow 80mm minimum behind panel for connectors and wiring.
Panel Cutout	H=45, W=92mm.

IN-uP4 Dimensions & Terminal Layout.

Front Panel Layout.

Super bright display 20mm (0.8"), 4 digits (7 segment).

Two setpoint (SP1 & SP2) indicator LEDs, for IN-uP4X model only.

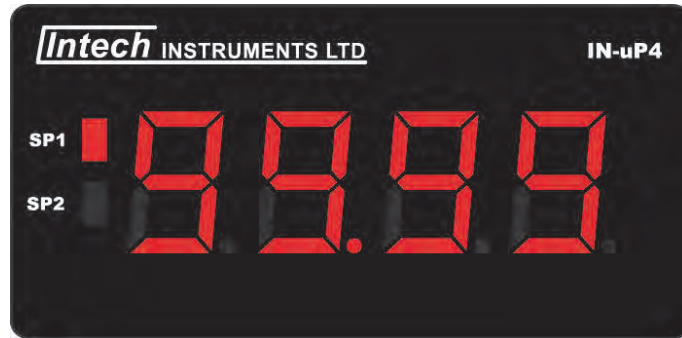

Back Panel Layout.

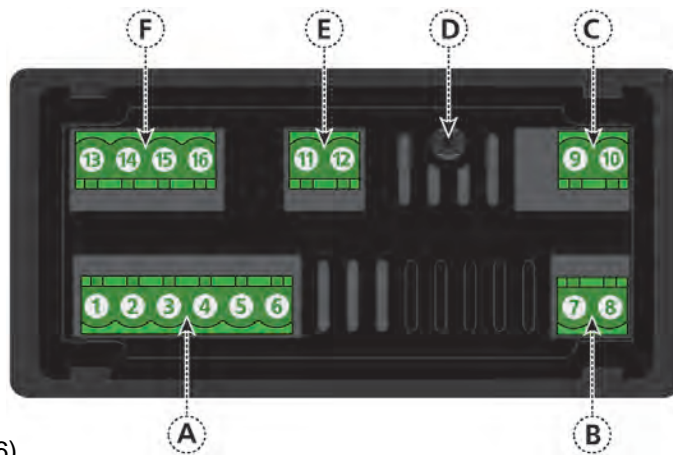

- A Universal input (Pins 1~6).
- B Universal Power supply (Pins 7~8).
- C Analogue output (Pins 9~10), IN-uP4X model only.
- D USB programming port.
- E Relay reset switch (Pins 11~12), IN-uP4X model only.
- F Relay output (Pins 13~16), IN-uP4X model only.

Front Indicator Dimensions.

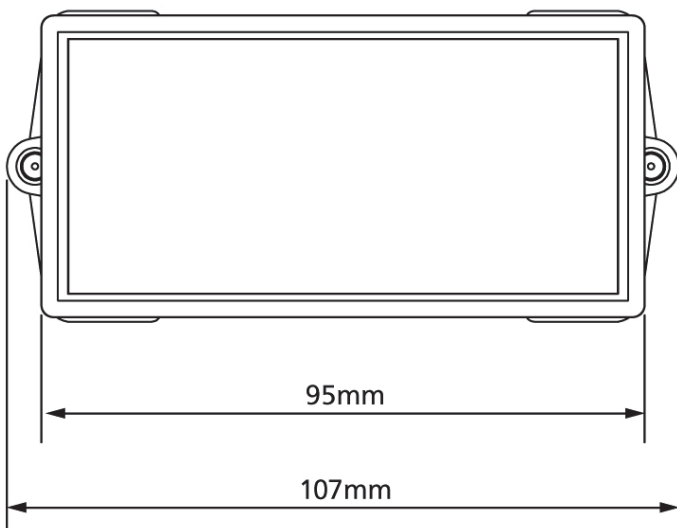

Side Dimensions.

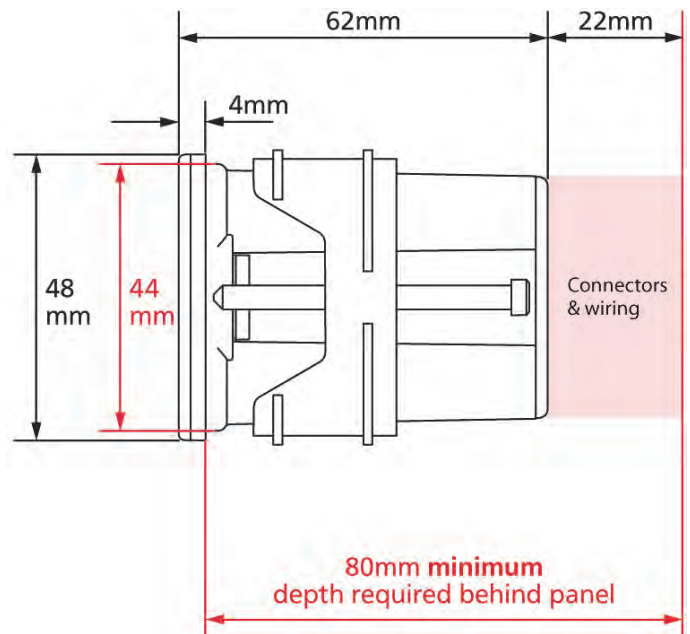

Top Panel Dimensions.

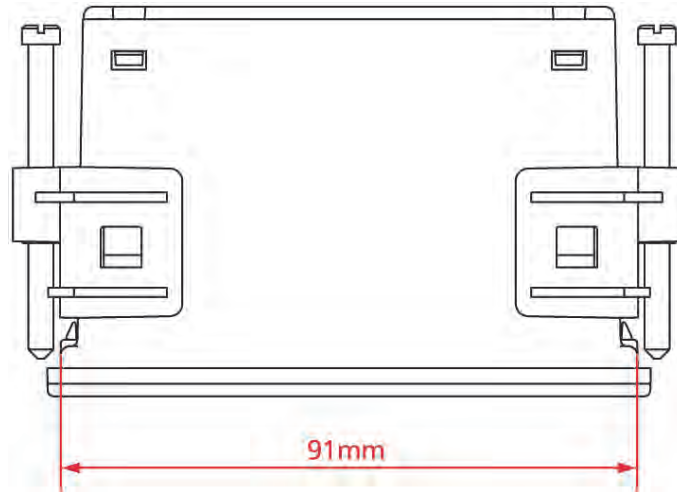

Installing uP Configure.

uP Configure offers a smart, no-fuss setup experience for your IN-uP4 universal indicator. It features USB powered programming (no power supply required!), and has been designed to simplify and speed up configuration.

Note: You must install uP Configure before connecting the IN-uP4 to your computer. If you have already connected the Indicator using the XU-USB key, please disconnect it before continuing.

1. Download the latest version of uP Configure from www.intech.co.nz/downloads
For ease of access, we recommend saving the install file on your desktop. If you cannot locate the install file, check whether your browser has saved it in your Downloads folder.
2. Extract the install file from the zip folder. Right-click on the zip folder and choose 'Extract All', (or extract the file using another extraction utility of your choice).
3. Double-click on the extracted 'uPConfigure.msi' install file. This will launch the uP Configure installer. Depending on your security settings, a 'Security Warning' dialogue may appear. If you see the security message, click 'Run'.

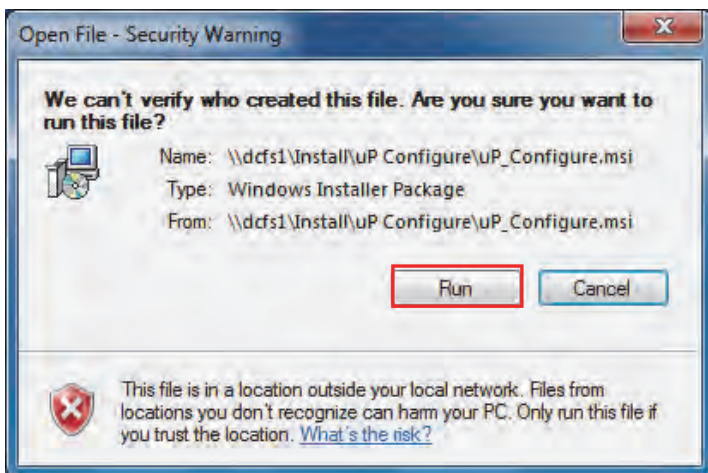

Note: uP Configure requires **Microsoft .NET Framework 2.0** to be installed first. If .NET 2.0 is not already installed, a prompt will advise this so you can download online from Microsoft. Windows 10/8.1/8 require Internet access to install .NET Framework 3.5/2.0

4. The uP Configure Setup Wizard will launch. Click 'Next'.

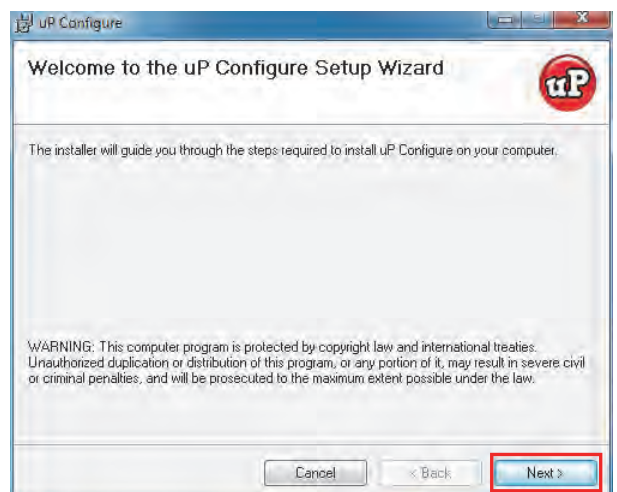

Note: An Administrator account or password will be required for installation. Contact your IT support for this if needed.

5. The wizard will prompt you to select an installation folder. You may accept the default installation folder, or select an alternative location by clicking 'Browse'. Click 'Next' to continue.

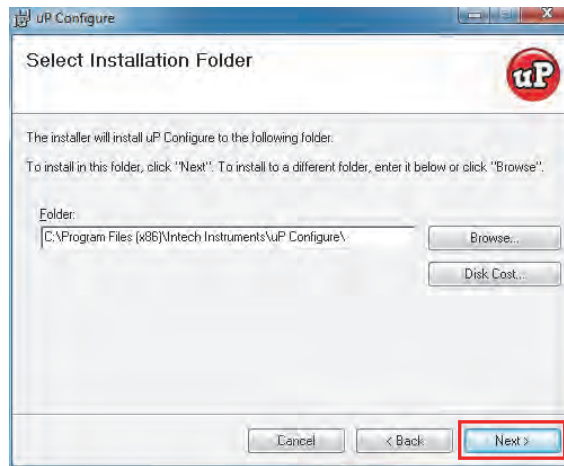

6. The wizard will ask for confirmation that you wish to begin the installation. Click 'Next' to continue.

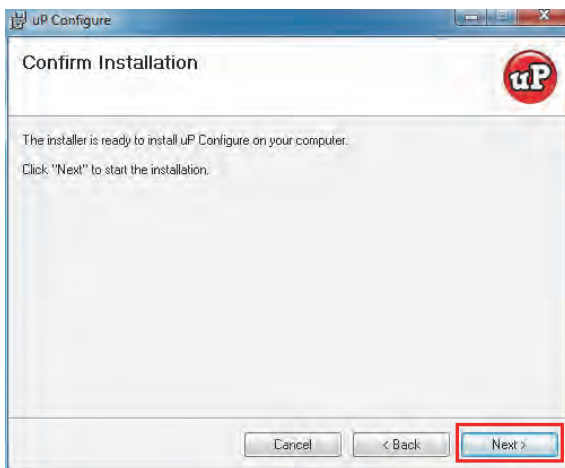

7. A User Account Control window may appear. Click 'Yes' to continue.

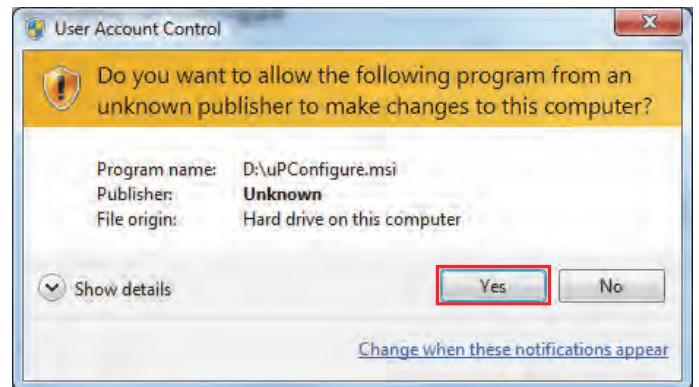

8. Wait while the install wizard installs uP Configure.
9. When the installation has successfully completed, the following dialog will appear. Click 'Close'.

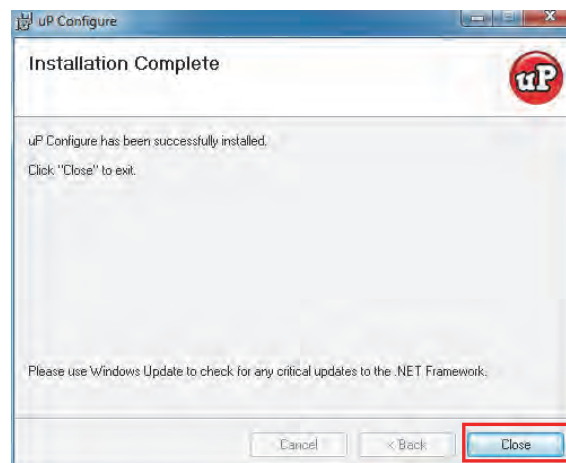

10. The XU-USB (Rev 1) key can now be connected to your computer's USB port. Windows will then install the required USB driver.

Note: The downloaded zip and installer files are no longer needed, and may be deleted or backed up safely if desired.

Connecting the XU-USB Key.

BEFORE YOU CONNECT:

- Ensure that you have an **XU-USB (Rev 1)** or later version. **Older XU-USB keys will not work with this product!**
- Install the uP Configure software before connecting the XU-USB (Rev 1) to your computer (see page 8). uP Configure may not be able to detect an indicator that was already connected to your computer at the time of installation.
- Ensure that all cables and adaptors are securely connected to both the XU-USB programming key and your indicator. Connecting your indicator with cables that are not firmly 'pushed in' could cause damage to your computer.

Connect the IN-uP4 to your computer's USB port using the XU-USB (Rev 1) key. The interface cable connects to the USB programming port on the unit's back panel (see page 6).

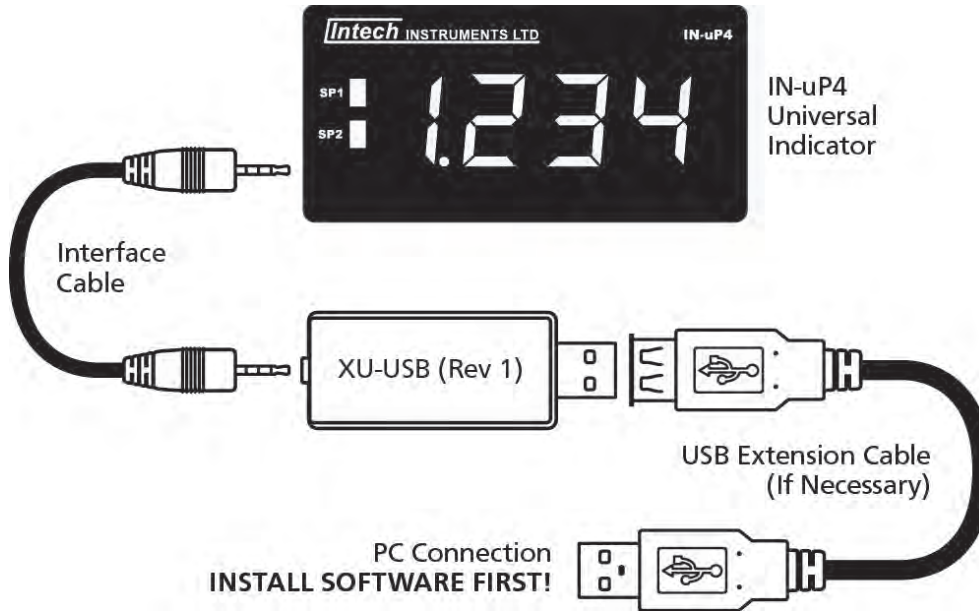

Note that the USB extension cable should only be used if there is difficulty accessing your computer's USB port. Use the Windows 'Safely remove hardware' function before unplugging the XU-USB from your computer.

Connecting uP Configure to the IN-uP4.

Double-click the uP Configure icon on your desktop to launch the uP Configure program:



With the IN-uP4 connected to your computer's USB port via the XU-USB (Rev 1) programming key, click the 'Connect' button. This will scan your computer's Com ports and automatically connect to your device.



If uP Configure cannot detect or connect to your device, try disconnecting and reconnecting the indicator, and then click 'Connect' again.

Using uP Configure Software Configuration.

The uP Configure software enables full configuration of your IN-uP4 universal indicator. To set up your indicator, only the USB connection is required - you do not need a power supply. uP Configure features a comprehensive help panel that will guide you through the setup of your IN-uP4 universal indicator. Helpful hints and explanations will appear when you adjust a setting using the uP Configure controls.

There are three main navigation pages/tabs: Input/Output, Setpoints and Advanced.

Input/Output.

- **Input Mode:** Options to select Temperature, mA, V, Digital Pulse or Potentiometer input.
- **Display:** Display brightness and decimal place settings.
- **Scaling/Offset:** For setting your input range, E.g. 4mA input = 0.0 display value, and 20mA input = 100.0 display value. Note: make sure you set the Decimal Places before you set the Custom Scaling/Offset.
- **Output (Retransmission):** Sets the output range, E.g. 0.0 display value = 4mA output, and 100.0 display value = 20mA output.

Setpoints. (Relay Output Model Only.)

- **Mode:** Select either alarm or control action.
- Setpoint Values, Hysteresis, Delay Values and Reset Switch Settings.

Advanced.

- Create Configuration Certificates.
- Import or export configuration settings.

uP Configure Interface Overview.

Main Navigation Tabs.

Input/Output, Setpoints, and Advanced configuration pages. (uP Configure will detect your indicator settings and will only display relevant tabs.)

Control Area.

Main control area for configuring your indicator. Any changes made in this area will bring up the Apply Bar below.

Connection Panel.

Disconnect link, connection status and live display.

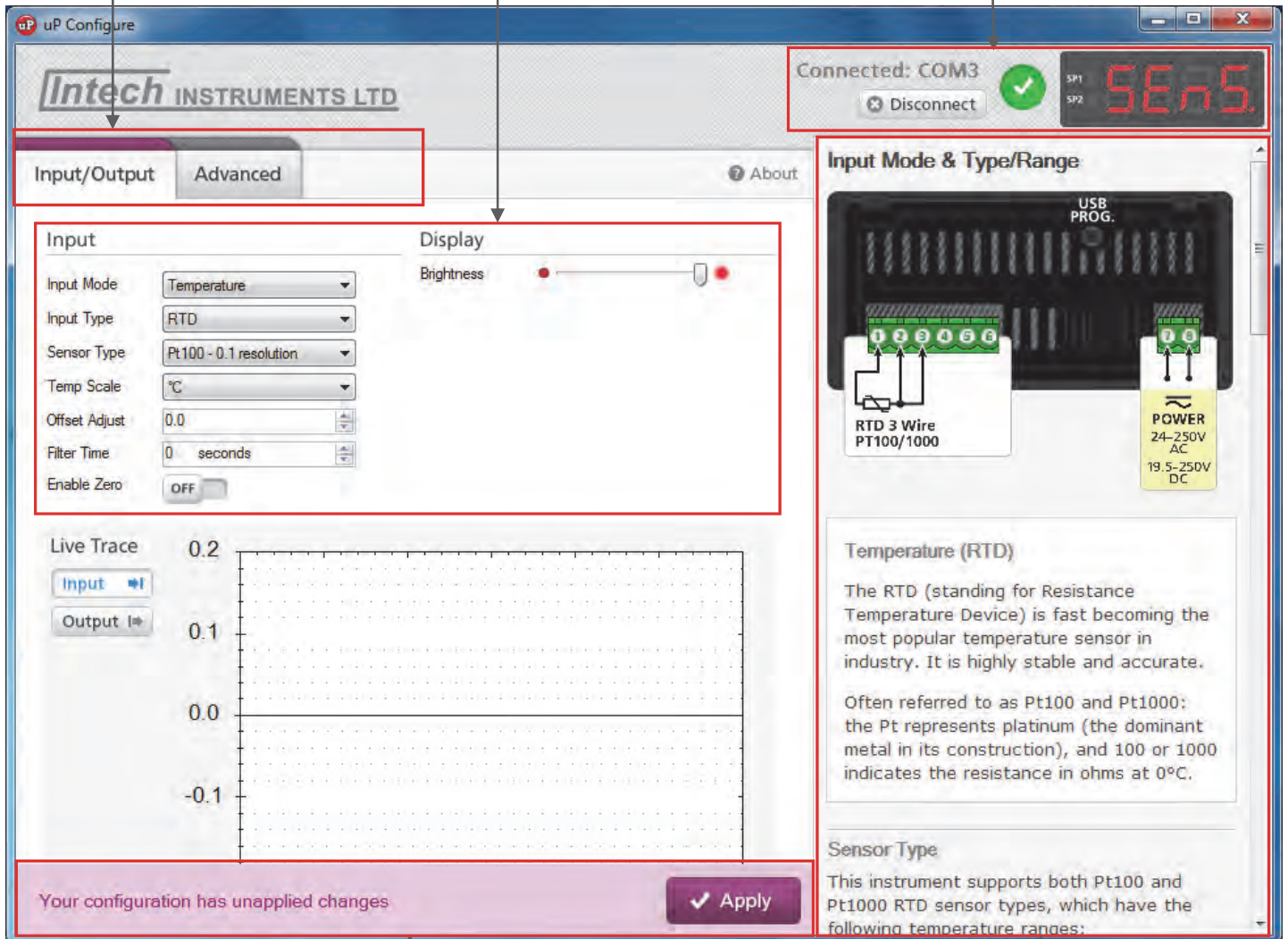

Apply Bar.

Appears if you have made any changes in the **Control Area**. uP Configure will not allow you to browse to a new tab in the **Main Navigation** with unapplied changes to your configuration.

Help Panel.

Diagrams, explanations, and helpful tips will automatically appear in this panel as you configure your indicator.

Input & Output Connection Diagrams.

Universal Analogue input wiring.

Terminal Pins 1~6, see page 6. The input terminal can be wired to suit many different input types as per the specifications on pages 4 and 5.

BEFORE YOU BEGIN WIRING:

1. Ensure that all programming is carried out BEFORE any wiring takes place!
2. Ensure that the power supply is disconnected. Refer to the diagram on page 6 for terminal location and numbering.

Voltage Input.

±200mVdc.

For low signal applications the indicator supports a $\pm 200\text{mVdc}$ range. Typical applications include measuring large DC currents using external current shunts.

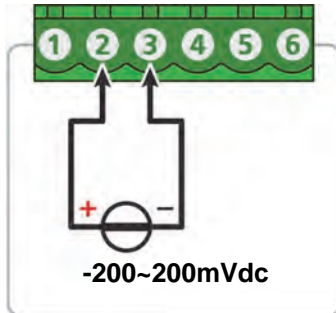

-200mV~1Vdc.

A -200mV to 1Vdc range is provided for interfacing to sensors and other electronic apparatus that provide this output.

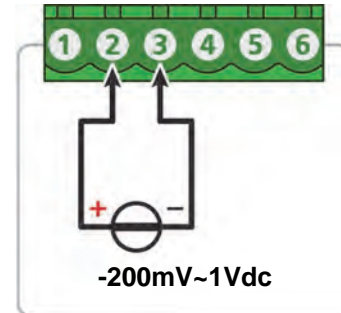

0~10Vdc.

0 to 10Vdc is a common process signal generated by transmitters, meters and PLCs. It would normally be scaled into engineering units by the indicator.

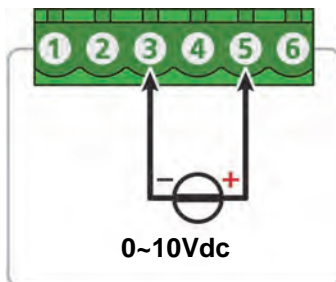

±10Vdc.

$\pm 10\text{Vdc}$ is a common process signal generated by transmitters, meters and PLCs. It would normally be scaled into engineering units by the indicator.

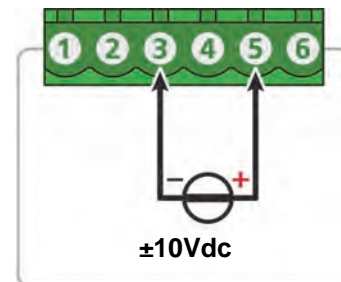

0~10V or ±10Vdc, 3 or 4 wire transmitter.

The IN-uP4 indicator can provide up to 25mA to power an external 3 or 4 wire transmitter, and at the same time measure the $0\sim 10\text{V}$ or $\pm 10\text{V}$ DC output signal.

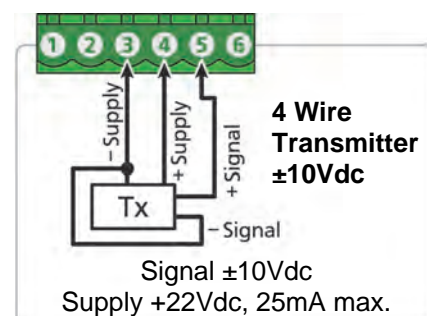
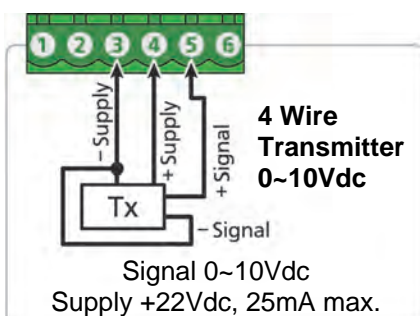
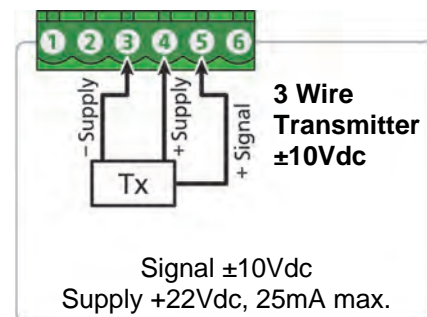
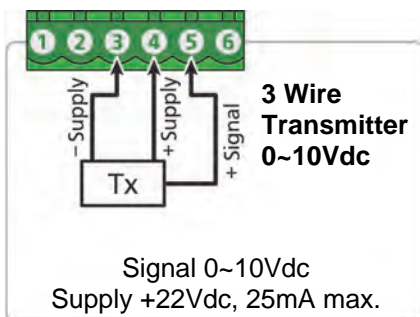

-10~30Vdc

This range is a general purpose voltage measuring range and would be typically used to measure battery voltages, power supply outputs, etc.

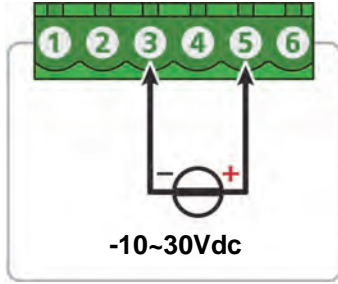

0~300Vdc

This higher voltage general purpose range is typically used to measure battery voltages, power supply outputs, etc.

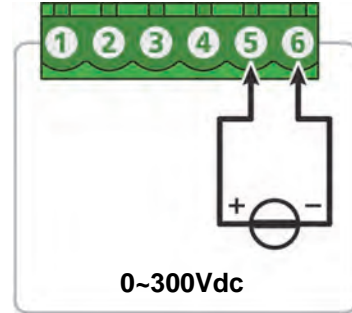

Current Input.

0/4~20mA

0/4~20mA is the most commonly used analogue signal in the industry, and is universally accepted. As a current loop, it is unaffected by voltage drops in cables, and can be transmitted over long distances without signal degradation.

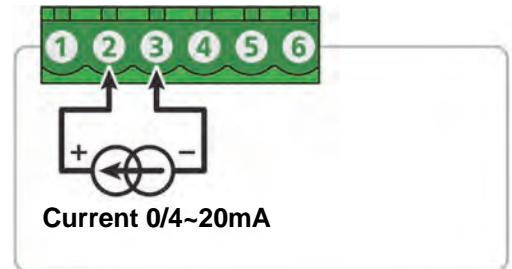

Sensor Power Supply:

The IN-uP4 indicator also has a transmitter power supply feature. The power supply will provide +22Vdc, 25mA max. The transmitter power supply is designed to power a field transmitter as the following drawings demonstrate:

2 Wire 4~20mA Loop Powered Transmitter

The IN-uP4 indicator connected to a 2 Wire 4~20mA Loop Powered Transmitter.

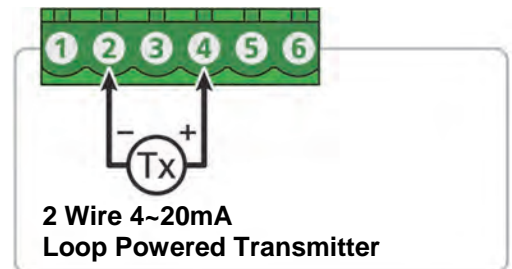

3 or 4 Wire 0/4~20mA, Transmitter

The indicator can provide up to 25mA to power an external 3 or 4 wire transmitter, and at the same time measure the 4~20mA signal.

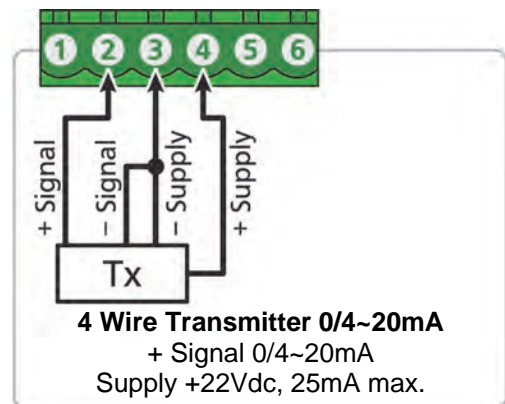
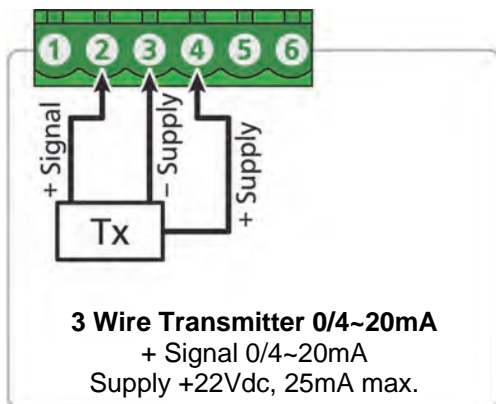

Note: Even if the IN-uP4 indicator is powered off, the loop current connection is maintained.

Thermocouple Input.

The thermocouple is one of the most common temperature sensors used in industry. It relies on the Seebeck coefficient between dissimilar metals. The thermocouple type is selected with reference to the application temperature range and environment. The most common thermocouple types for general purpose applications are J and K type.

Supported Thermocouple Types and Ranges.		
B	0°C	+1820°C
E	-100°C	+1000°C
J	-200°C	+1000°C
K	-200°C	+1372°C
N	-180°C	+1300°C
R	-50°C	+1760°C
S	-50°C	+1760°C
T	-200°C	+400°C

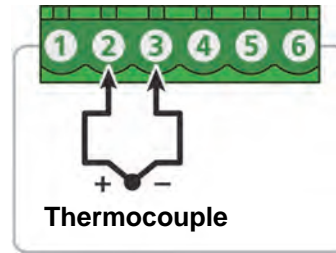

RTD Input.

The RTD (standing for Resistance Temperature Device) is highly stable and accurate, and is fast becoming the most popular temperature sensor in industry. Often referred to as **Pt100** and **Pt1000**, the Pt represents platinum (the dominant metal in its construction), and 100/1000 is the resistance in ohms at 0°C.

Supported RTD types/ranges		
Pt100	-200°C	+320°C
Pt1000	-200°C	+320°C

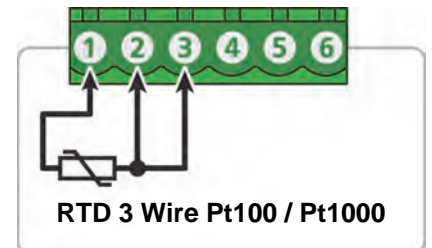
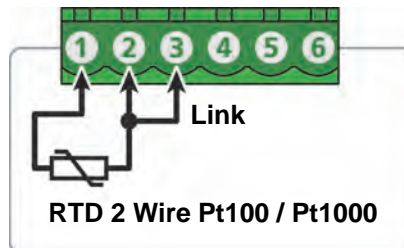

NTC Input.

NTC (Negative Temperature Coefficient), is a particular type of thermistor. NTC's are popular in the HVAC industry due to their low cost, but have a limited temperature range which makes them less popular in general industry. The biggest issue with their general acceptance is that there is no standard that covers interoperability between different thermistor manufacturers.

Supported NTC types/ranges		
10K (Beta 3984)	-55°C	+125°C
10K (Beta 3435)	-50°C	+110°C

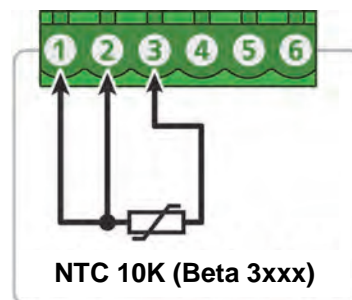

Pulse & Frequency Input.

General Frequency mode

General Frequency mode allows an NPN or PNP input (up to 2KHz) to be measured and scaled to any engineering unit. The indicator can also provide up to 25mA to power an external device.

Flow rate mode

Flow Rate mode enables an input from an NPN or PNP paddle type flow meter to be converted to a flow rate. The input signal (up to 2KHz) is converted into a flow rate by programming the unit with the sensor manufacturer's K-factor value. The indicator can also provide up to 25mA to power a 3 wire NPN paddle type flow sensor.

RPM mode

RPM mode enables an input from an NPN or PNP proximity sensor to be converted to an RPM (Revs Per Minute) value. The input signal (up to 2KHz) is converted into RPM by programming the unit with the pulses per revolution value. The indicator can also provide up to 25mA to power a 3 wire NPN proximity sensor.

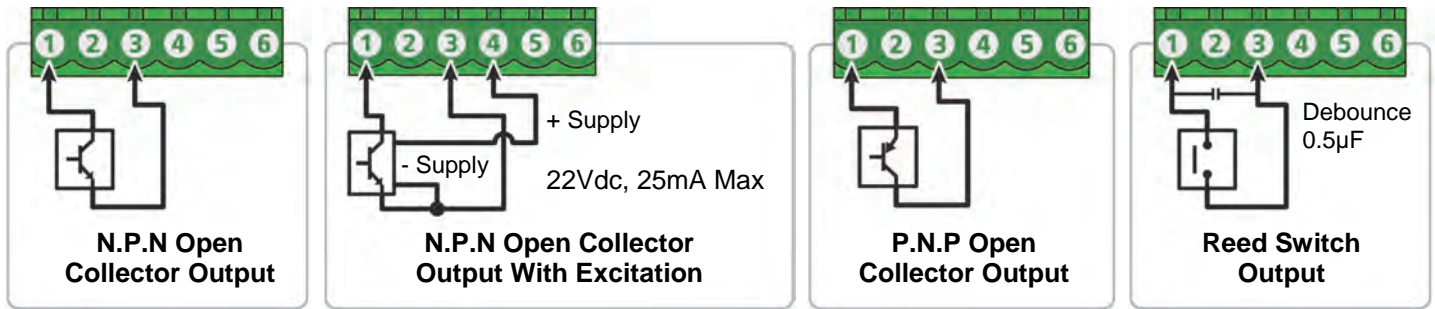

Potentiometer Input.

A 3 wire potentiometer is typically used to measure position. The low, medium or high potentiometer range can be programmed to your unit using the uP Configure software. These ranges must be calibrated using the two point calibration method.

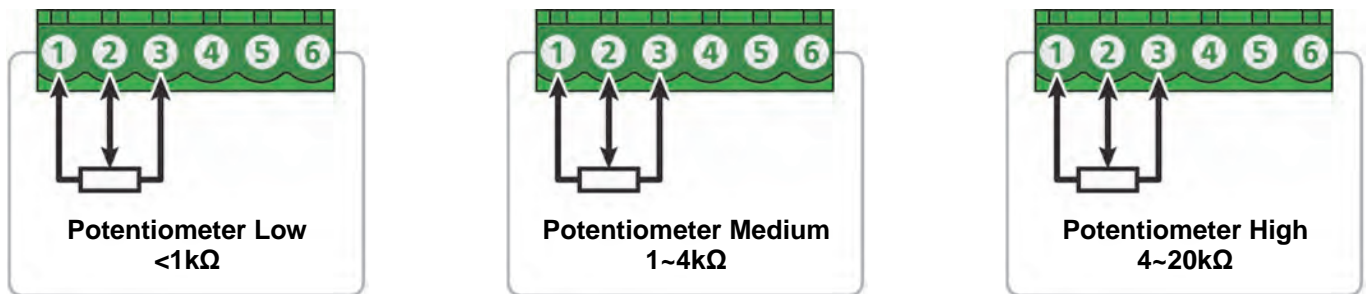

Analogue Output - IN-uP4X only.

Terminal pins 9~10, also see page 6.

For analogue output with the IN-uP4X, wire as shown (right).

The analogue output can be scaled to suit your application using the uP Configure software under the Input/Output tab.

E.g.

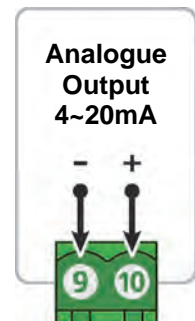
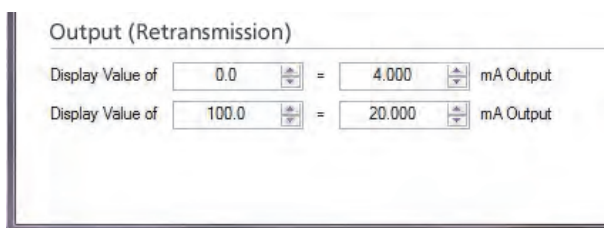

This means that when the IN-uP4 display shows the value of 0.0, the retransmission output will be at 4mA, and when the display shows the value of 100.0, the retransmission output will be at 20mA.

Relay Outputs - IN-uP4X only.

Terminal pins 13~16, also see page 6.

For relay outputs with the IN-uP4X, wire them as shown (right).

The relay setpoints can be configured using uP Configure software for a variety of alarm or control functions.

The manual relay reset switch (terminal pins 11~12), is optional and can be used to force the alarm out of alarm state manually. It is also an option for a latched alarm reset action.

The relay reset switch options are selectable under the Setpoints tab of the uP Configure software.

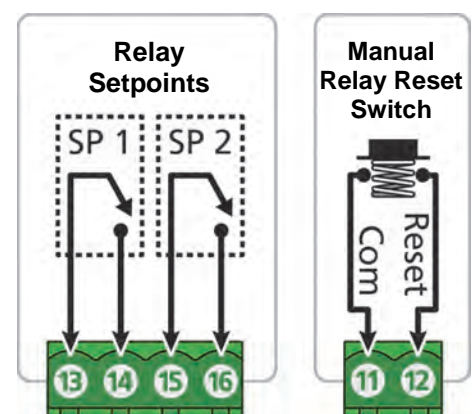

Power Supply.

Terminal pins 7~8, also see page 6.

The IN-uP4 indicator accepts a wide power supply range that suits both mains AC voltage and 24Vdc applications (24~250Vac / 19.5~250Vdc). The indicator has been designed so that a DC power supply can be connected either way around.

Note: The original IN-uP4 model had two different Power Supply options. Each indicator type can be distinguished from the Power supply Connector plug as follows:

Model	Connector Colour	Power Supply Voltage
(Rev 1)	Green	Universal 24~250Vac / 19.5~250Vdc.
HV	Orange	85~265Vac / 100~300Vdc.
LV	Black	24Vac / 19~40Vdc.



IN-uP4 Wiring, Installation and Maintenance.

THE IN-uP4 IS TO BE INSTALLED AND SERVICED BY SERVICE PERSONNEL ONLY. NO OPERATOR / USER SERVICEABLE PARTS.

BEFORE YOU BEGIN WIRING: Ensure that all programming is carried out BEFORE any wiring takes place! All power and signals must be de-energised BEFORE connecting any wiring.

IN-uP4 Wiring & Installation.

Mounting:

* Also refer to Connection Diagrams and Notes (Pages 6 & 7).

- 1) Mount so the terminals are in a clean environment behind the panel.
- 2) Minimum clearance behind the panel is to be no less than 80mm.
- 3) Do not subject to vibration or excess temperature or humidity variations.
- 4) Avoid mounting in cabinets with power control equipment.
- 5) Allow 10mm minimum clearance between the IN-uP4 terminals and ANY conductive material.

Analogue Signal Wiring:

- 1) All signal cables should be good quality overall screened INSTRUMENTATION CABLE with the screen earthed at one end only.
- 2) Signal cables should be laid a minimum distance of 300mm from any power cables.
- 3) For 2 wire current loops, 2 wire voltage signals or 2 wire current signals, B5102ES is recommended. For 3 wire transmitters and RTDs B5103ES is recommended.
- 4) It is recommended that you do not ground analogue signals and use power supplies with ungrounded outputs.
- 5) Lightning arrestors should be used when there is a danger from this source.
- 6) Refer to diagrams for connection information.

Thermocouple Extension Wire:

- 1) Use the correct thermocouple extension or compensation cable. i.e. Thermocouple type, insulation type, correct colour coding.
- 2) It is recommended to install extension or compensation cable in a grounded conduit by themselves, or use overall screened cable with the screen earthed at one end only. Never run electrical wires in the same conduit.
- 3) All wires that must be spliced should be soldered, or a proper thermocouple termination block used.
- 4) Lightning arrestors should be used if there is a chance from this source.

Thermocouples:

- 1) Avoid locating the thermocouple where it will be in a direct flame.
- 2) Never insert a porcelain or refractory tube suddenly in a hot area. Pre-heat gradually while installing.
- 3) Locate it where the average temperature will be measured. It should be representative of the mass. If necessary use several thermocouples to obtain the average temperature.
- 4) Immerse the thermocouple far enough so that the measuring junction is entirely in the temperature to be measured: nine to ten times the diameter of the protection tube is recommended. Heat conducted away from the junction causes an error in reading.
- 5) If the thermocouple is mounted horizontally and the temperature is above the softening point of the tube, a support should be provided to prevent the tube sagging. Otherwise install the tube vertically.
- 6) Keep the junction head and cold junction in the approximation of the ambient temperature. Especially in the Noble Metal Class.

RTDs:

- 1) Avoid locating the RTD where it will be in a direct flame.
- 2) Locate it where the average temperature will be measured. It should be representative of the mass.
- 3) Immerse the RTD far enough so that the measuring point is entirely in the temperature to be measured; nine to ten times the diameter of the protection tube is recommended. Heat that is conducted away from the measuring point causes an error in reading.

Power Supply Wiring:

- 1) Use Only Instrument Quality Power Supplies.
- 2) A readily accessible disconnect device and a 1A, 250Vac overcurrent device, must be in the power supply wiring.

IN-uP4 Commissioning.

- 1) **WARNING: Ensure that all programming is carried out BEFORE any wiring takes place!**
- 2) Check that the IN-uP4 has been set to the correct input ranges and all functions such as Upscale/Downscale Drive etc. Observe polarity and the correct terminal connections for wiring correctly. Only use certified calibration equipment. For Thermocouple calibration, place the IN-uP4 and calibration equipment directly next to each other, in still air, with no direct sunshine. Allow the CJC junctions to equalise in temperature before commencing calibration. Lower temperature ranges are affected more by the CJC Junction (allow more time to equalise).
- 3) Once the above conditions have been met, and the wiring checked, apply power to the IN-uP4 and the loops and/or sensors. Allow at least a 5 minute warm-up period.
- 4) **Thermocouple Inputs only:** Due to the limits of error in a standard Thermocouple probe, and standard extension wire and compensating wire, an error can occur. E.g. In a type K Thermocouple installation an error of 2.2°C or 0.75% FSO can occur (whichever is greater).
The IN-uP4 has an integral CJC sensor, the enclosure must be assembled and installed where it avoids drafts and temperature differences across terminals. Once installation is complete, close the cabinet door and allow the cabinet to reach equilibrium. This may take several hours. Place all the Thermocouple probes into a calibrated thermal bath at the temperature of interest or use a calibration standard Thermocouple at the same immersion depth and temperature of interest and adjust the Zero until the two temperatures agree.
- 5) **Calibration Check:** Take a reading of the value being measured on the input, and ensure that this agrees with the level being indicated by the IN-uP4 display. Adjust for any differences. It is recommended to measure both a high and low value and compare these readings with your calibration device.

IN-uP4 Maintenance.

DC Voltage and Current Inputs:

- 1) Check the Sensor or Transducer supplying the signal to the IN-uP4 for wear or damage and replace if defective.
- 2) Check the cables connected to the Sensor or Transducer.
- 3) Repeat (5) of commissioning. Do it regularly - at least once per year.

Thermocouple Inputs:

- 1) Replace defective protection tubes - even if they look good they may not be air or gas tight.
- 2) Check extension and compensating cable circuits, especially cables entering the Thermocouple sensor head.
- 3) Do not use the same Chromel-Alumel (Type K) Thermocouple below 540C if it was used above 860C.
- 4) Repeat (5) of commissioning. Do it regularly - at least once per year.

RTD Inputs:

- 1) Replace defective protection tubes - even if they look good they may not be air or gas tight.
- 2) Check cables entering the RTD sensor head.
- 3) Repeat (5) of commissioning. Do it regularly - at least once per year.