

LPI-R RTD Transmitter.

Isolating, Linearised, 3 Wire RTD Input, to 4~20mA Output, Loop Powered Transmitter.

Features.

- Pt100 RTD Standard Input.
- Isolated Input to Output 2.0kV
- Field Programmable Input Ranges. (LPI-R-P)
- High Accuracy.
- Linear With Temperature
- 40~200mV Output Test Signal.
- LED Indication of Loop Current.
- Low Cost.
- Compact DIN Rail Mount Enclosure.
- Available Standard or Special Calibration.
- Reverse Polarity Protection.



Z495

Other LPI- models include:
 LPI-B :Bridge / Strain Gauge;
 LPI-D :DC;
 LPI-F :Frequency;
 LPI-K :Resistance;
 LPI-N :Differential Pt100 RTD;
 LPI-P :Potentiometer;
 LPI-T :Thermocouple;
 LPI-DO2 :DO2, LCD Display;
 LPI-pH :pH, LCD Display;
 LPI-ORP :ORP, LCD Display;

Ordering Information.

- LPI-R-F-X Standard, 0~100C Input, Upscale, Fixed Input Range Calibration.
- LPI-R-F---Special Range Special Fixed Input Range Calibration.
 IR SB
- LPI-R-P-X Standard, 0~100C Input, Upscale, Programmable Input Range Calibration.
- LPI-R-P---Special Range Special Programmable Input Range Calibration.
 IR SB

Standard Unit Pt100 input, upscale sensor break. Other types of RTD available in special range calibration are JIS Pt100, Pt250, Pt500, Pt1000, CU10, CU100, Ni100 or specify.

INPUT RANGES (DIN PT100)								SENSOR BREAK	
deg C	IR	deg C	IR	deg F	IR	deg F	IR	STATE	SB
0~20C	1	-10~10C	21	0~40F	41	-20~20F	61	Upscale	US
0~25C	2	-10~20C	22	0~50F	42	-20~40F	62	Downscale	DS
0~30C	3	-10~40C	23	0~60F	43	-20~80F	63		
0~40C	4	-20~20C	24	0~80F	44	-40~40F	64		
0~50C	5	-20~30C	25	0~100F	45	-40~60F	65		
0~60C	6	-25~25C	26	0~120F	46	-50~50F	66		
0~70C	7	-25~50C	27	0~140F	47	-50~100F	67		
0~75C	8	-30~20C	28	0~150F	48	-60~40F	68		
0~80C	9	-50~50C	29	0~160F	49	-100~100F	69		
0~90C	10	-50~100C	30	0~180F	50	-100~200F	70		
0~100C	11	-50~150C	31	0~200F	51	-100~300F	71		
0~110C	12	-100~100C	32	0~220F	52	-200~200F	72		
0~120C	13	-100~200C	33	0~240F	53	-200~400F	73		
0~125C	14	-200~200C	34	0~250F	54	-400~400F	74		
0~150C	15	-200~400C	35	0~300F	55	-400~800F	75		
0~200C	16	20~40C	36	0~400F	56	40~80F	76		
0~250C	17	50~100C	37	0~500F	57	100~200F	77		
0~300C	18	50~150C	38	0~600F	58	100~300F	78		
0~400C	19	100~200C	39	0~800F	59	200~400F	79		
0~600C	20	100~500C	40	0~1200F	60	200~1000F	80		
Special Input Range			Z	Special Input Range			Z		

Ordering Examples.

- LPI-R-P-5 LPI-R; Programmable; 0~50C In; Upscale Break; Loop Powered 4~20mA Output.
- LPI-R-F-56-DS LPI-R; Fixed Range; 0~400F In; Downscale Break; Loop Powered 4~20mA Output.

Quality Assurance Programme.

The modern technology and strict procedures of the ISO9001 Quality Assurance Programme applied during design, development, production and final inspection grant the long term reliability of the instrument.

LPI-R Specifications.

RTD Input		Pt100 DIN (3 Wire Type) Standard. Sensor Current = 0.8mA Nominal. Lead Wire Resistance = 10Ω/Wire Max. Field Programmable Zero: -200C (-400F) to 200C (400F). (LPI-R-P Only.) Field Programmable Span: 20C (40F) to 400C (800F). (LPI-R-P Only.) Suitable for 2 Wire Connection. (Offset Calibration needed.) Other Types of RTD Available. JIS Pt100, Pt250, Pt500, Pt1000, CU10, CU100, Ni100 or specify.
Output	-Damping	3sec Selectable with H1. (LPI-R-P Only.)
	-mA	2 wire 4~20mA. (Loop Powered.)
	-mV Test	40~200mV ±1% @ 4~20mA. Other Test Voltages Available. e.g. 1~5V. Note. mV Test Increases Power Supply & Decreases Load Resistance.
Power Supply		8~33Vdc.
Supply Voltage Sensitivity		<±0.005%/V FSO.
Output Load Resistance		800Ω @ 24Vdc. (50Ω/V Above 8Vdc.)
Maximum Output Current		Limited to <28mA.
Sensor Fail	-Upscale	23mA Min.
	-Downscale	3.8mA Max.
Accurate to		<±0.1% FSO Typical.
Linearity & Repeatability		<±0.1% FSO Typical.
Ambient Drift		<±0.02%/C FSO Typical.
Noise Immunity		125dB CMRR Average. (2.0kVac RMS Limit.)
EMC Compliances		Emissions EN 55022-A. Immunity EN 50082-1, <1% Effect FSO Typical.
Isolation Test Voltages		2000Vac/dc Input to Output for 1min.
Response Time		200msec Typical. (10 to 90% 50msec Typical.)
Operating Temperature		0~70C.
Storage Temperature		-20~80C.
Operating Humidity		5~85%RH Max. Non-Condensing.
Dimensions and Construction		L=79, W=22.5, H=85mm. Polyamide Thermoplastic Rail Mount Enclosure.

Product Liability. This information describes our products. It does not constitute guaranteed properties and is not intended to affirm the suitability of a product for a particular application. Due to ongoing research and development, designs, specifications, and documentation are subject to change without notification. Regrettably, omissions and exceptions cannot be completely ruled out. No liability will be accepted for errors, omissions or amendments to this specification. Technical data are always specified by their average values and are based on Standard Calibration Units at 25C, unless otherwise specified. Each product is subject to the 'Conditions of Sale'.

Warning: These products are not designed for use in, and should not be used for patient connected applications. In any critical installation an independent fail-safe back-up system must always be implemented.

Examples of Input Connection.

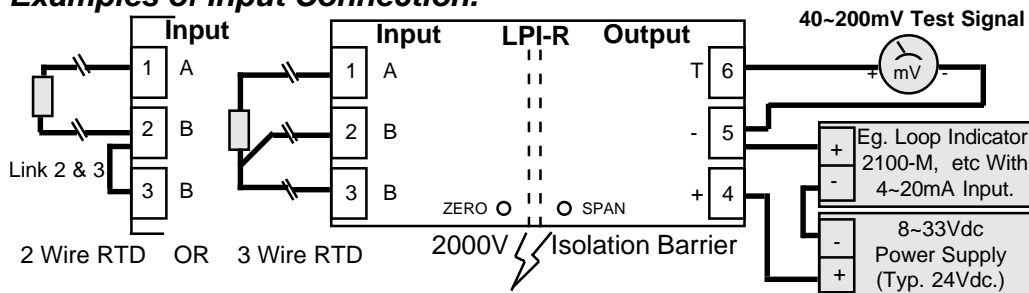

Terminations.

Input	1	A
	2	B
	3	B
Output	4	+mA
	5	-mA
	6	mV TEST

Enclosure Dimensions.

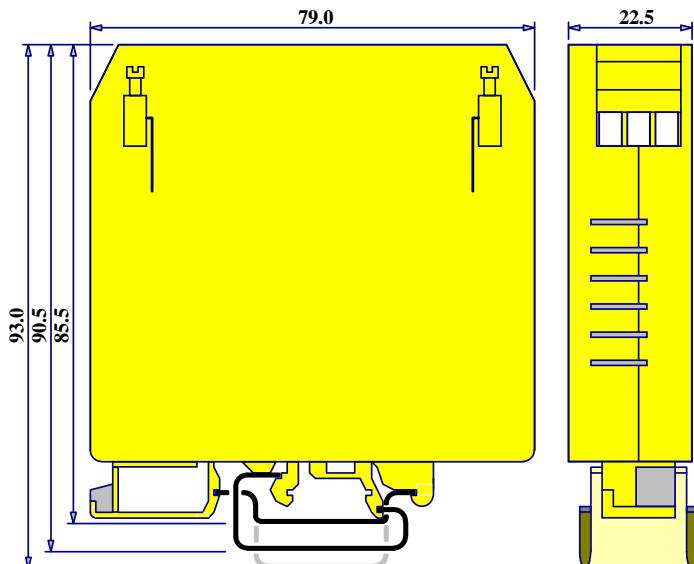

Maximum Load Vs Power Supply.

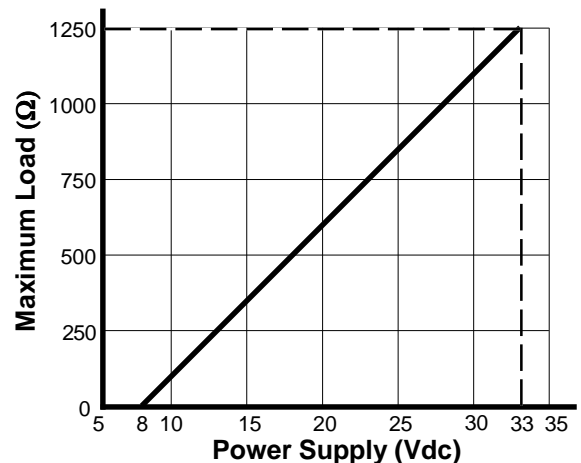

LPI-R-P ONLY

LPI-R-P Input Programming.

If the input range is not listed in the programming table, use the following formulae to work out the Zero and Span DIP switch settings for gain.

$$\text{deg C Span Gain} = \frac{1200}{\text{deg C High} - \text{deg C Low}}$$

$$\text{deg F Spain Gain} = \frac{2400}{\text{deg F High} - \text{deg F Low}}$$

$$\text{deg C Zero Gain} = \frac{\text{deg C Low}}{5}$$

$$\text{deg F Zero Gain} = \frac{\text{deg F Low}}{10}$$

If Zero is: 1/ Positive, put S3-1 OFF. 2/ Negative, put S3-1 ON.

Gain Value	1	2	4	8	16	32
DIP Switch No.	1	2	3	4	5	6

So if a gain value of 28 is required, put DIP switch No's 3, 4, 5 OFF (ie, gains of 4 + 8 + 16 = 28) and all the other DIP switches ON.
Dip switches are accessed by seperating the two halves of the LPI-R enclosure.

- Note:** (a) Enter the Zero or Span gain value into the appropriate Zero or Span DIP switch.
(b) If the *ZERO GAIN* exceeds **63**, then the input range must be factory calibrated.

LPI-R-P Input Range Programming Table.

- Notes:** 1/ Switch status 1 = ON, 0 = OFF, X = DON'T CARE.
2/ Input ranges with '*' beside them require more adjustment by the Span trimpot.

Input Range C (Put S3-2 OFF)	Input Range F (Put S3-2 ON)	S1-Zero						S2-Span						S3-Function				
		1	2	3	4	5	6	1	2	3	4	5	6	1	2	3	4	
0~20C	0~40F	1	1	1	1	1	1	1	1	0	0	0	0	X				
0~25C	0~50F	1	1	1	1	1	1	1	1	1	1	0	0	X				
0~30C	0~60F	1	1	1	1	1	1	1	1	1	0	1	0	X				
0~40C	0~80F	1	1	1	1	1	1	1	1	0	0	0	0	X				
0~50C	0~100F	1	1	1	1	1	1	1	1	1	1	0	0	X				
0~60C	0~120F	1	1	1	1	1	1	1	1	0	1	0	1	X				
0~70C*	0~140F*	1	1	1	1	1	1	1	1	0	1	1	1	X				
0~75C	0~150F	1	1	1	1	1	1	1	1	1	1	1	0	X				
0~80C	0~160F	1	1	1	1	1	1	1	1	0	0	0	0	X				
0~90C*	0~180F*	1	1	1	1	1	1	1	1	0	1	0	0	X				
0~100C	0~200F	1	1	1	1	1	1	1	1	1	1	0	1	X				
0~110C	0~220F	1	1	1	1	1	1	1	1	0	0	1	0	X				
0~120C	0~240F	1	1	1	1	1	1	1	1	1	0	1	0	X				
0~125C*	0~250F*	1	1	1	1	1	1	1	1	1	0	1	0	X				
0~150C	0~300F	1	1	1	1	1	1	1	1	1	1	1	0	X				
0~200C	0~400F	1	1	1	1	1	1	1	1	1	0	0	1	X				
0~250C*	0~500F*	1	1	1	1	1	1	1	1	0	1	0	1	X				
0~300C	0~600F	1	1	1	1	1	1	1	1	1	1	0	1	X				
0~400C	0~800F	1	1	1	1	1	1	1	1	0	0	1	1	X				
0~600C	0~1200F	1	1	1	1	1	1	1	1	1	0	1	1	X				
-10~10C	-20~20F	1	0	1	1	1	1	1	1	1	1	0	0	1				
-10~20C	-20~40F	1	0	1	1	1	1	1	1	1	1	1	0	1				
-10~40C	-20~80F	1	0	1	1	1	1	1	1	1	1	1	0	1				
-20~20C	-40~40F	1	1	0	1	1	1	1	1	1	0	0	0	1				
-20~30C	-40~60F	1	1	0	1	1	1	1	1	1	1	1	0	1				
-25~25C	-50~50F	0	1	0	1	1	1	1	1	1	1	1	0	1				
-25~50C	-50~100F	0	1	0	1	1	1	1	1	1	1	1	1	0	1			
-30~20C	-60~40F	1	0	0	1	1	1	1	1	1	1	1	0	1				
-50~50C	-100~100F	1	0	1	0	1	1	1	1	1	1	0	0	1				
-50~100C	-100~200F	1	0	1	0	1	1	1	1	1	1	1	0	1				
-50~150C	-100~300F	1	0	1	0	1	1	1	1	1	0	0	1	1				
-100~100C	-200~200F	1	1	0	1	0	1	1	1	1	0	0	1	1				
-100~200C	-200~400F	1	1	0	1	0	1	1	1	1	1	0	1	1				
-200~200C	-400~400F	1	1	1	0	1	0	1	1	0	0	1	1	1				
-200~400C	-400~800F	1	1	1	0	1	0	1	1	1	0	1	1	1				
20~40C	40~80F	1	1	0	1	1	1	1	1	1	1	0	0	0				
50~100C	100~200F	1	0	1	0	1	1	1	1	1	1	1	0	0				
50~150C	100~300F	1	0	1	0	1	1	1	1	1	0	0	1	1				
100~200C	200~400F	1	1	0	1	0	1	1	1	1	1	0	0	1				
100~500C	200~1000F	1	1	0	1	0	1	1	1	0	0	1	1	1				

SET TO '1' FOR FAHRENHEIT.
Set to '0' for CELSIUS. SET TO '1' FOR FAHRENHEIT.
Set to '0' for UPSCALE Sensor Break. Set to '1' for DOWNSCALE Sensor Break.
Set to '1' for UPSCALE Sensor Break. Set to '0' for DOWNSCALE Sensor Break.

Plan View of LPI-R-P Adjustments.

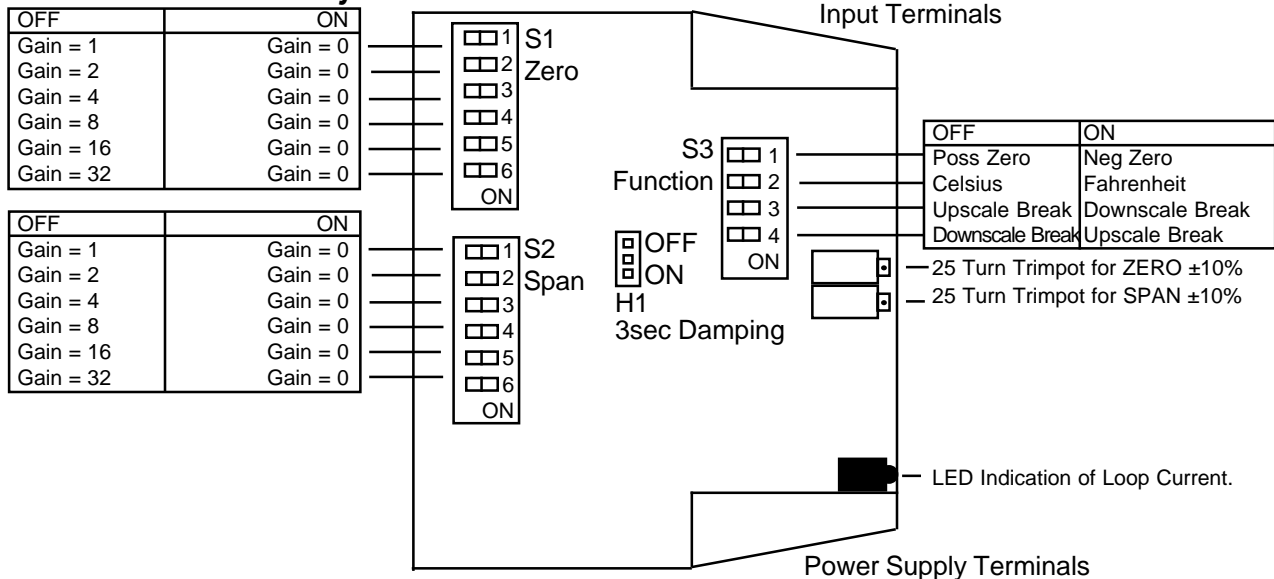

The Proper Installation & Maintenance of LPI-R.

All power and signals must be de-energised before connecting any wiring, or altering any Jumpers or Dip Switches.

LPI-R MOUNTING.

- (1) Mount in a clean environment in an electrical cabinet on DIN or EN mounting rail.
- (2) Draft holes must have minimum free air space of 20mm. Foreign matter must not enter or block draft holes.
- (3) Do not subject to vibration or excess temperature or humidity variations.
- (4) Avoid mounting in cabinets with power control equipment.
- (5) To maintain compliance with the EMC Directives the LPI-B is to be mounted in a fully enclosed steel cabinet. The cabinet must be properly earthed, with appropriate input / output entry points and cabling.

WIRING.

- (1) All cables should be good quality overall screened INSTRUMENTATION CABLE with the screen earthed at one end only.
- (2) Signal cables should be laid a minimum distance of 300mm from any power cables.
- (3) For 2 wire current loops Austral Standard Cables B5102ES is recommended. For 3 wire transmitters and RTD's Austral Standard Cables B5103ES is recommended.
- (4) It is recommended that you do not ground current loops and use power supplies with ungrounded outputs.
- (5) Lightning arrestors should be used when there is a danger from this source.
- (6) Refer to diagrams for connection information.

RTD'S.

- (1) Avoid locating the RTD where it will be in a direct flame.
- (2) Locate it where the average temperature will be measured. It should be representative of the mass.
- (3) Immerse the RTD far enough so that the measuring point is entirely in the temperature to be measured; nine to ten times the diameter of the protection tube is recommended. Heat that is conducted away from the measuring point causes an error in reading.

COMMISSIONING.

- (1) Once all the above conditions have been carried out and the wiring checked apply power to the LPI-R loop and allow five minutes for it to stabilize.
- (2) Due to differences in cable resistance in the RTD legs or errors within the RTD itself a small zero error may occur (usually less than 0.5C). To remove this error use a calibration standard RTD at the same immersion depth and adjust the Zero Pot in the top of the LPI-R enclosure with a small screwdriver, until the two levels agree. (Clockwise to increase the output reading and anticlockwise to decrease the output reading)

MAINTENANCE.

- (1) Check RTD's in place - with a calibration RTD at the same immersion depth.
- (2) Do it regularly - at least once every 6 months.
- (3) Replace defective protection tubes - even if they look good they may not be air or gas tight.
- (4) Check cables entering the RTD sensor head.

Intech INSTRUMENTS LTD
www.intech.co.nz
 Christchurch Ph: +64 3 343 0646
 Auckland Ph: 09 827 1930
 Email: sales@intech.co.nz