

uP4-Din

Universal Input Indicator, DIN Rail Mount,
Controller, Transmitter.



Installation Guide.

uP4-Din Installation Guide Index.

Description.	Page 3
Features.	Page 3
Ordering Information.	Page 3
Product Liability.	Page 3
Specifications.	Page 4
uP4-Din Dimensions & Terminal Layout.	Page 6
<i>Layout.</i>	Page 6
<i>Dimensions.</i>	Page 6
Installing uP Configure.	Page 7
Connecting the XU-USB Key.	Page 9
<i>Transparent Cover.</i>	Page 9
<i>Connecting uP Configure to the uP4-Din.</i>	Page 9
Using the uP Configure Software Configuration.	Page 9
uP Configure Interface Overview.	Page 10
Input & Output Connection Diagrams.	Page 11
<i>Voltage Input.</i>	Page 11
<i>Current Input.</i>	Page 12
<i>Thermocouple Input.</i>	Page 13
<i>RTD Input.</i>	Page 13
<i>NTC Input.</i>	Page 13
<i>Potentiometer Input.</i>	Page 13
<i>Pulse & Frequency Input.</i>	Page 14
<i>Analogue Output - uP4-Din-R2A only.</i>	Page 15
<i>Relay Outputs.</i>	Page 15
<i>Universal Power Supply.</i>	Page 15
uP4-Din Wiring, Installation and Maintenance.	Page 16
<i>uP4-Din Wiring and Installation.</i>	Page 16
<i>Mounting.</i>	Page 16
<i>Analogue Signal Wiring.</i>	Page 16
<i>Thermocouple Extension Wire.</i>	Page 16
<i>Thermocouples.</i>	Page 16
<i>RTDs.</i>	Page 16
<i>Power Supply Wiring.</i>	Page 16
<i>uP4-Din Commissioning.</i>	Page 16
<i>uP4-Din Maintenance.</i>	Page 17
Troubleshooting.	Page 17

uP4-Din

Universal Input Indicator,
DIN Rail Mount, Dual Relay Output,
Retrans option.

Description.

The uP4-Din is a DIN rail mount, universal single input indicator, which gives easy interface with a wide range of sensors. It is also fitted with two relay outputs (with two setpoint indicator LEDs), and one optional retransmission output (4~20mA or 0~10Vdc selectable). The uP4-Din has a 4-digit LED front display, and a universal power supply of 24~250Vac / 19.5~250Vdc.

Setup and calibration is simple, using 'uP Configure' software (version 1.5.23 or later), with step-by-step instructions.



Features.

- Universal Input with Indication.
- DIN Rail Mount.
- Universal AC or DC supply.
- Two Relay Outputs (with Setpoint LEDs).
- Option to add One Retrans Analogue Output (4~20mA or 0~10Vdc selectable).
- Programmable via USB Port using **uP Configure** software and the **XU-USB** (Rev 1) key.
- Simple setup and calibration.
- 4-digit LED display with Transparent Cover.
- Sensor power supply for powering external transmitter.
- Low cost.

Ordering Information.

CODE	DESCRIPTION
uP4-Din-R2	Universal Input Indicator, DIN rail mount with Two Relay Outputs.
uP4-Din-R2A	Universal Input Indicator, DIN rail mount with Two Relay Outputs plus One Analogue Output (4~20mA or 0~10Vdc selectable).

Universal Power Supply of 24~250Vac / 19.5~250Vdc.

Note: The uP4-Din Universal Input Indicator is pre-programmed for RTD Pt100 input as standard.

To program the uP4-Din requires the XU-USB (Rev 1) Programming Key:

XU-USB (Rev 1)	USB Programming Key for programming uP4-Din using uP Configure Programming software. Note: XU-USB must be (Rev 1) or later! Older versions will NOT connect with the uP4-Din. (Same Key as used for programming XU Series transmitters, 2400-A16, Z-2400-Sleeper, Z-2400-A2 Series and IN-uP4.)
-----------------------	--



Product Liability. This information describes our products. It does not constitute guaranteed properties and is not intended to affirm the suitability of a product for a particular application. Due to ongoing research and development, designs, specifications, and documentation are subject to change without notification. Regrettably, omissions and exceptions cannot be completely ruled out. No liability will be accepted for errors, omissions or amendments to this specification. Technical data are always specified by their average values and are based on Standard Calibration Units at 25C, unless otherwise specified. Each product is subject to the 'Conditions of Sale'.

Warning: These products are not designed for use in, and should not be used for patient connected applications. In any critical installation an independent fail-safe back-up system must always be implemented.

Intech INSTRUMENTS LTD

www.intech.co.nz

Specifications.

Input Specifications:

Excitation - Sensor Power Supply +22Vdc \pm 10%, 25mA max.

Voltage DC Input Specifications:

mV Range	-200mV~200mV.
V Range	0~1V, 0~10V, -10~30V, 0~300Vdc.
Minimum Input Resistance	1M Ω .
Temperature Drift	<50ppm/ $^{\circ}$ C.
Linearity and Repeatability	< \pm 0.02% FSO typical.
Response Time	100msec.
USB Programmable Zero	0~ \pm 99% of the Span.
USB Programmable Span	95% of FSO.

Current Input Specifications:

mA Range	0~20mA (4~20mA).
Input Resistance	10 Ω .
Maximum Over-range	50mAdc Continuous.
Temperature Drift	<50ppm/ $^{\circ}$ C.
Linearity and Repeatability	< \pm 0.02% FSO typical.
Response Time	100msec.
USB Programmable Zero	0~ \pm 99% of the Span.
USB Programmable Span	1 μ A~24mAdc.

Thermocouple Input Specifications:

Thermocouple Types	B, E, J, K, N, R, S, T.
Input Impedance	1M Ω Minimum.
T/C Lead Resistance	100 Ω Maximum.
Cold Junction Compensation	-10~70 $^{\circ}$ C.
Accuracy	E, J, K, N, T < \pm 1 $^{\circ}$ C/ C. B, R, S < \pm 2 $^{\circ}$ C.
Temperature Drift	E, J, K, N, T < \pm 0.05 $^{\circ}$ C/ C. B, R, S < \pm 0.2 $^{\circ}$ C.
CJC Error	< \pm 2 $^{\circ}$ C.
Sensor Fail	Upscale or Downscale Selectable (Upscale Default).
Response Time	400msec.

RTD Input Specifications:

RTD Input	Pt100 or Pt1000 DIN 3-wire Type. (2-wire can be used with offset calibration.)
Sensor Current	0.3mA Nominal.
Lead Wire Resistance	Pt100: 50 Ω /wire Maximum. 0.02% FSO Offset Error per Ω of Lead Resistance. Pt1000: 20 Ω /wire Maximum. 0.002% FSO Offset Error per Ω of Lead Resistance.
Accuracy	Better than 0.2 $^{\circ}$ C.
Temperature Drift	<0.007 $^{\circ}$ C/ C.
Sensor Fail	Upscale or Downscale Selectable (Upscale Default).
Linearity (Pt100)	0.02% FSO for Span Inputs \leq 200 $^{\circ}$ C. 0.1% FSO for Span Inputs \leq 300 $^{\circ}$ C.
Linearity (Pt1000)	0.02% FSO for Span Inputs \leq 200 $^{\circ}$ C. 0.2% FSO for Span Inputs \leq 300 $^{\circ}$ C.
Response Time	400msec.

NTC Thermistor Input Specifications:

NTC Sensor Types	10K (Beta 3984) -55~125 $^{\circ}$ C. 10K (Beta 3435) -50~110 $^{\circ}$ C.
Response Time	100msec.
Accuracy	Better than 0.4 $^{\circ}$ C.
Temperature Drift	<50ppm/ $^{\circ}$ C.

Pulse & Frequency Input Specifications:

Input Type	Open Collector: NPN, 24Vdc Max. PNP, 5Vdc Max.
Frequency Range	0~2000Hz.
Temperature Drift	<50ppm/°C.
Response Time	100msec.
Software Modes	General Frequency, Flow Rate or RPM.

Potentiometer Input Specifications:

Potentiometer input	3-wire.
Excitation voltage	Variable.
Potentiometer resistance	<1kΩ low pot; 1~4kΩ med pot; 4~20kΩ high pot.
Field programmable zero	0~90% of span.
Field programmable span	0.1~100%.
Linearity and repeatability	<±0.05% FSO typical.
Temperature Drift	<50ppm/°C.
Response time	100msec.

Output Specifications:**Analogue Output:** Output type software selectable.

mA Range	0~20mA (4~20mA) Active.
V Range	0~10Vdc Active.
Isolation	1400Vrms for 1 minute. Working voltage 125V.
Resolution	0~20mA = 1μA. 0~10Vdc = 1mV.
Output Drive	20mA, 600Ω at 12Vdc.
Temperature Drift	<50ppm/°C.
Accuracy / Repeatability	0.05% of FSO.

Relay Outputs: 2 Isolated Relays with LED indication on each output.

Functions	2 on Board Controllers can be used as Set Point (SV), Switching Differential, Auto/Manual, Manual Output Setting, Dual Action Control, Single Action Control, Heat/Cool, Cool Only, Heat Only.
Relay Type & Ratings	Relay 1: Form A, 3A max 120/240Vac or 28Vdc (resistive load). Relay 2: Form C, 10A max 120/240Vac or 28Vdc (resistive load).
Life Expectancy	100K cycles minimum at full load rating.

Power Supply Specifications: 24~250Vac / 19.5~250Vdc (47-63Hz, 6VA max).

Isolation	2300Vrms for 1 minute to all inputs and outputs.
-----------	--

Certification & Compliance:

Immunity to Industrial Locations	EN 61326-1.
Emission	CISPR 11 Class A (EN 61326).
Safety Requirements for Electrical Equipment for Measurement Control, and Laboratory Use:	EN 61010-1 General Requirements. EN 61010-2-030 Particular Requirements for Testing and Measure Circuits.

Environment Specifications:

Operating Temperature	-10~50°C
Operating Humidity	5~85% RH.
Storage Temperature	-20~60°C.
Altitude	Up to 2000m above sea level.

Case Specifications:

Enclosure Rating	IP20.
DIN Rail Mount	35mm.
Display	4 digits with Plastic Protective Flap.
Weight	177g (including plugs).
Dimensions	H=112mm, W=23mm, D=120mm.

uP4-Din Dimensions & Terminal Layout.

Layout.

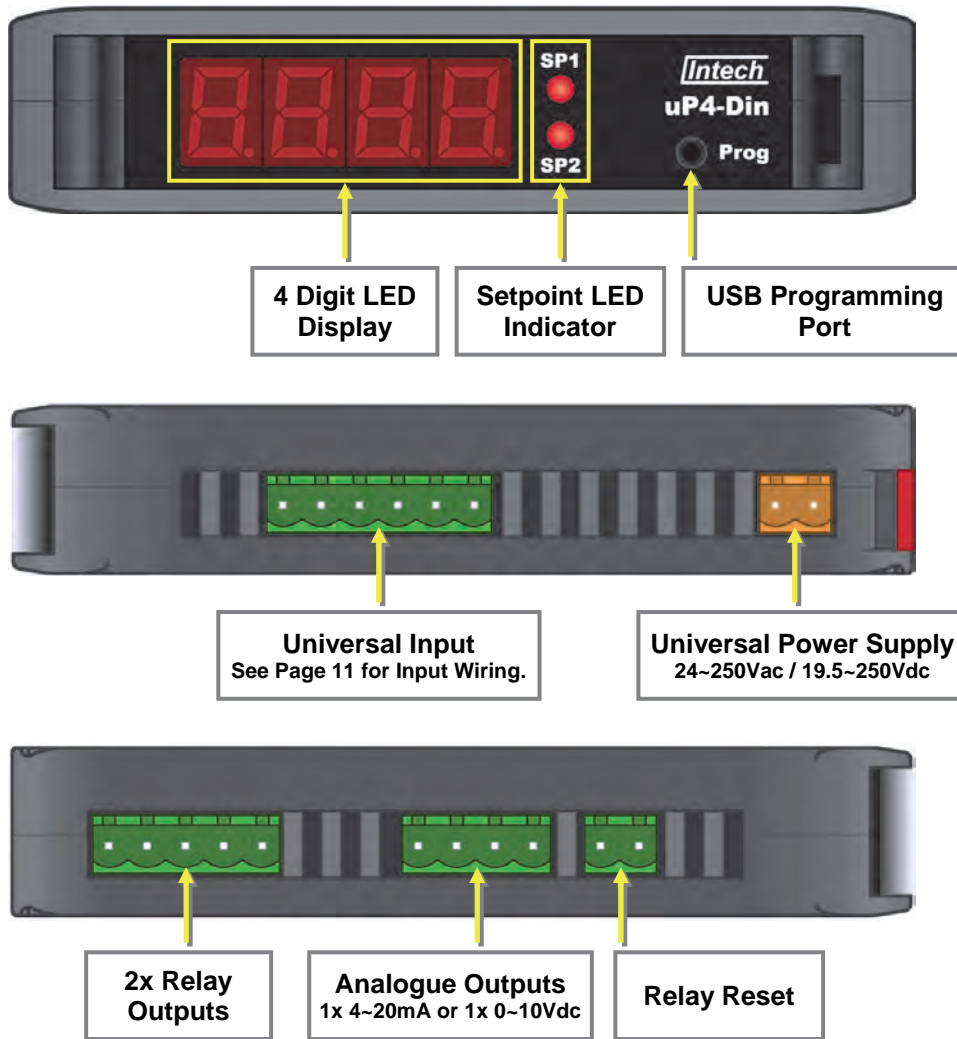

Dimensions.

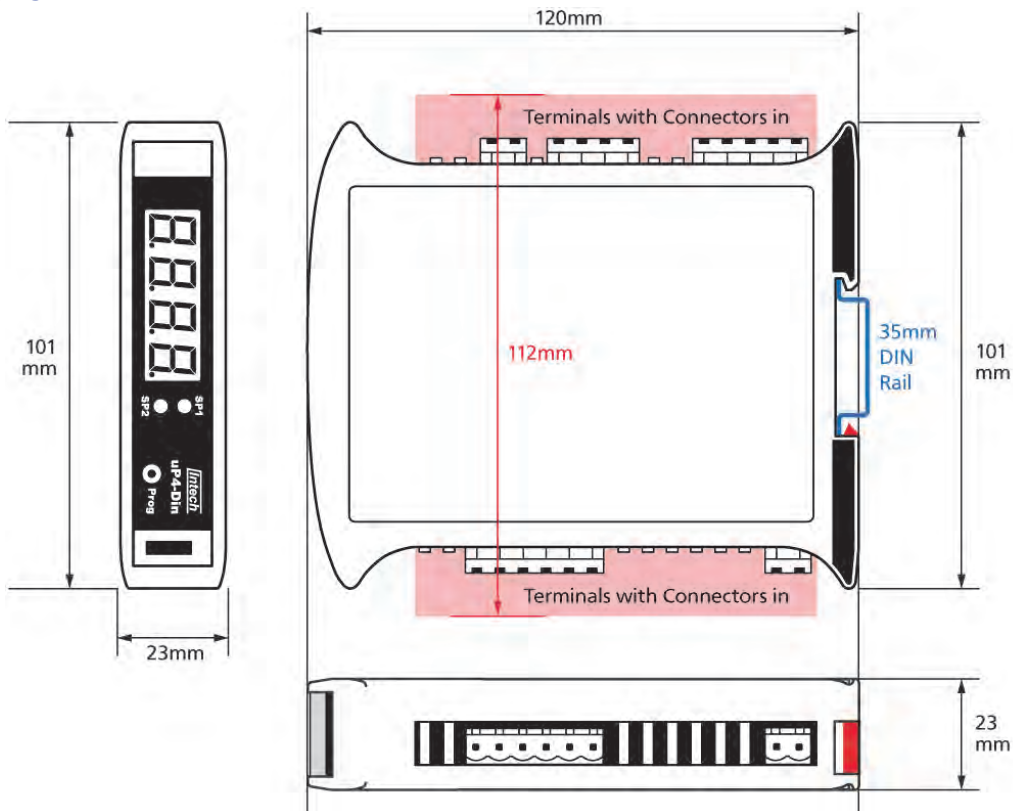

Installing uP Configure (Ver 1.5.23).

uP Configure (Ver 1.5.23 or later) offers a smart, no-fuss setup experience for your uP4-Din device. It features USB powered programming (no power supply required!), and has been designed to simplify and speed up configuration.

Note: You must install uP Configure before connecting the uP4-Din to your computer. If you have already connected the uP4-Din using the XU-USB key, please disconnect it before continuing.

1. Download the latest version of uP Configure from www.intech.co.nz/downloads
For ease of access, we recommend saving the install file on your desktop. If you cannot locate the install file, check whether your browser has saved it in your Downloads folder.
2. Extract the install file from the zip folder. Right-click on the zip folder and choose 'Extract All', (or extract the file using another extraction utility of your choice).
3. Double-click on the extracted 'uPConfigure.msi' install file. This will launch the uP Configure installer. Depending on your security settings, a 'Security Warning' dialogue may appear. If you see the security message, click 'Run'.

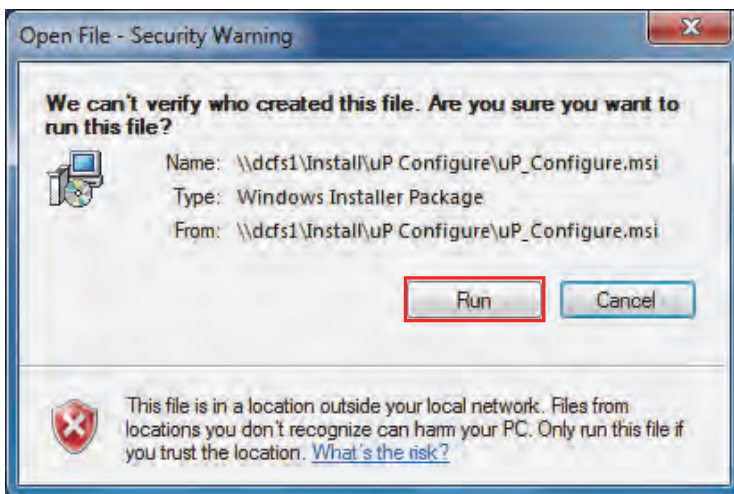

Note: uP Configure requires **Microsoft .NET 2.0** to be installed first. If .NET 2.0 is not already installed, a prompt will advise this so you can download online from Microsoft.

4. The uP Configure Setup Wizard will launch. Click 'Next'.

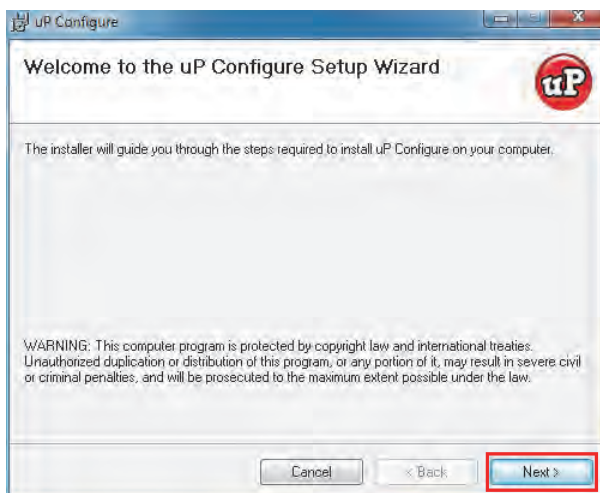

Note: An Administrator account or password will be required for installation. Contact your IT support for this if needed.

5. The wizard will prompt you to select an installation folder. You may accept the default installation folder, or select an alternative location by clicking 'Browse'. Click 'Next' to continue.

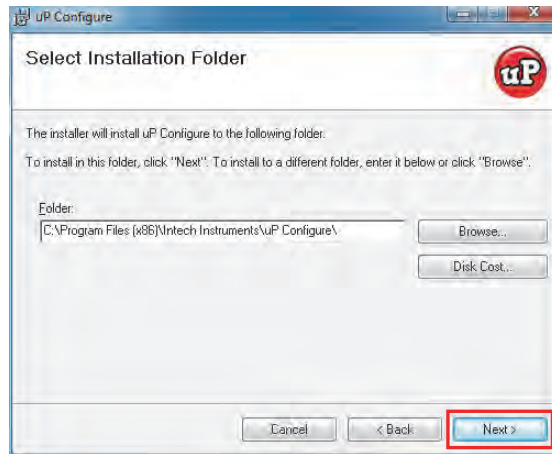

6. The wizard will ask for confirmation that you wish to begin the installation. Click 'Next' to continue.

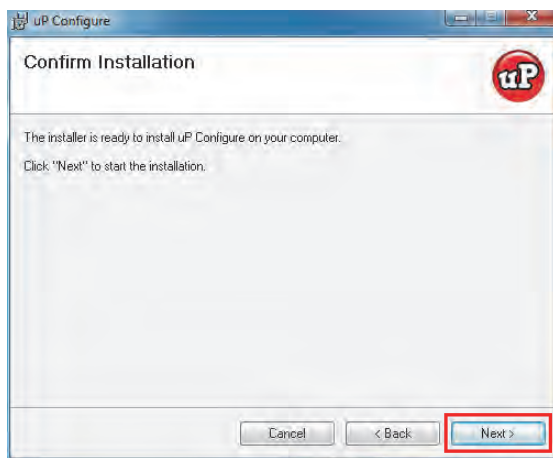

7. A User Account Control window may appear. Click 'Yes' to continue.

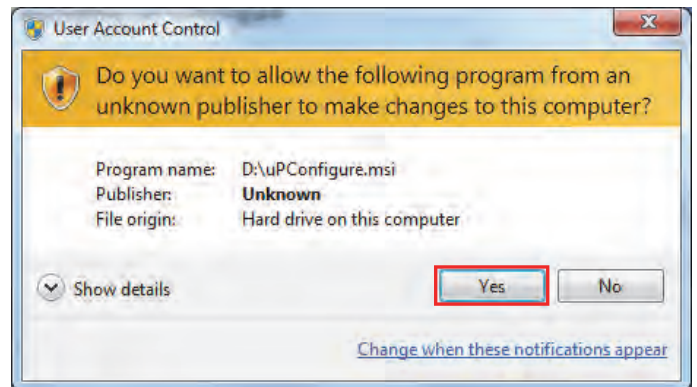

8. Wait while the install wizard installs uP Configure.
9. When the installation has successfully completed, the following dialog will appear. Click 'Close'.

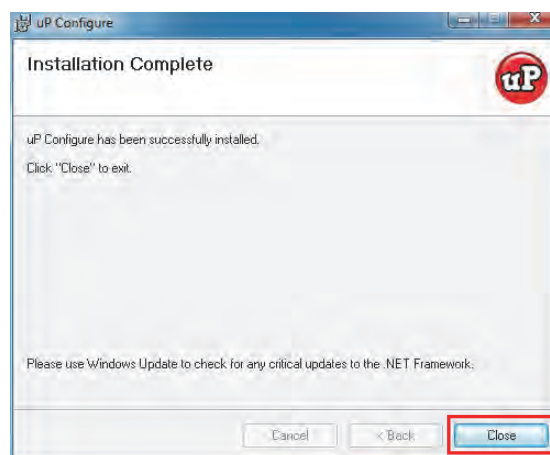

10. The XU-USB (Rev 1) key can now be connected to your computer's USB port. Windows will then install the required USB driver.

Note: The downloaded zip and installer files are no longer needed, and may be deleted or backed up safely if desired.

Connecting the XU-USB Key.

Transparent Cover.

The transparent plastic cover over the front panel provides protection (mainly from dust accumulation over time) to the uP4-Din display and programming port. The transparent cover must be opened to access the USB Programming Port (see page 6). To open the cover, gently slide a blade or a screwdriver into the gap between the plastic cover and the unit case at the bottom and then flick the cover upwards.

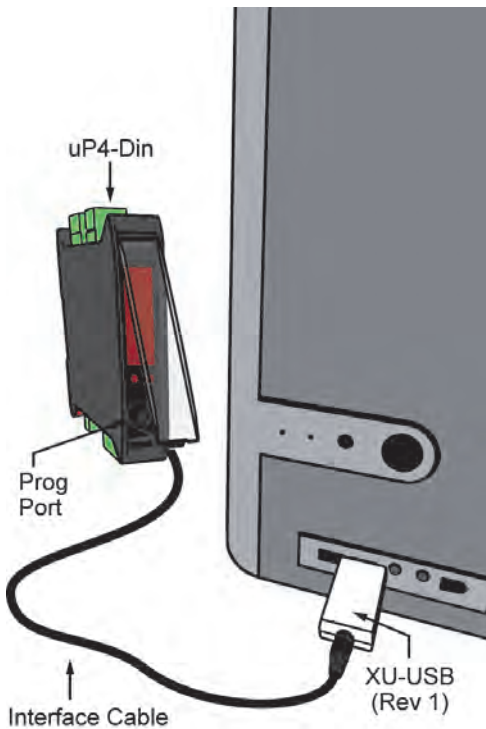

BEFORE YOU CONNECT:

- Ensure that you have an **XU-USB (Rev 1)** or later version. **Older XU-USB keys will not work with this product!**
- Install the uP Configure software before connecting the XU-USB (Rev 1) to your computer (see page 7). uP Configure may not be able to detect a uP4-Din device that was already connected to your computer at the time of installation.
- Ensure that all cables and adaptors are securely connected to both the XU-USB programming key and your uP4-Din. Connecting your uP4-Din with cables that are not firmly 'pushed in' could cause damage to your computer.

Connect the uP4-Din to your computer's USB port using the XU-USB (Rev 1) key. The interface cable connects to the USB programming port on the unit's front panel (see page 6).

Note that the USB extension cable should only be used if there is difficulty accessing your computer's USB port. Use the Windows 'Safely remove hardware' function before unplugging the XU-USB from your computer.

Connecting uP Configure to the uP4-Din.

Double-click the uP Configure icon on your desktop to launch the uP Configure program:



With the uP4-Din connected to your computer's USB port via the XU-USB (Rev 1) programming key, click the 'Connect' button. This will scan your computer's Com ports and automatically connect to your device.



If uP Configure cannot detect or connect to your device, try disconnecting and reconnecting the uP4-Din, and then click 'Connect' again.

Using uP Configure Software Configuration.

The uP Configure software enables full configuration of your uP4-Din device. To set up your uP4-Din, only the USB connection is required - you do not need a power supply. uP Configure features a comprehensive help panel that will guide you through the setup of your uP4-Din. Helpful hints and explanations will appear when you adjust a setting using the uP Configure controls.

There are three main navigation pages/tabs: Input/Output, Setpoints and Advanced.

Input/Output.

- **Input Mode:** Options to select Temperature, mA, V, Digital Pulse or Potentiometer input.
- **Display:** Display brightness and decimal place settings.
- **Scaling/Offset:** For setting your input range, E.g. 4mA input = 0.0 display value, and 20mA input = 100.0 display value. Note: make sure you set the Decimal Places before you set the Custom Scaling/Offset.
- **Output (Retransmission):** Sets the output range, E.g. 0.0 display value = 4mA output, and 100.0 display value = 20mA output.

Setpoints. (Relay Output Model Only.)

- **Mode:** Select either alarm or control action.
- Setpoint Values, Hysteresis, Delay Values and Reset Switch Settings.

Advanced.

- Create Configuration Certificates.
- Import or export configuration settings.

uP Configure Interface Overview.

Main Navigation Tabs.
Input/Output, Setpoints, and Advanced configuration pages. (uP Configure will detect your uP4-Din settings and will only display relevant tabs.)

Control Area.
Main control area for configuring your uP4-Din. Any changes made in this area will bring up the Apply Bar below.

Connection Panel.
Disconnect link, connection status and live display.

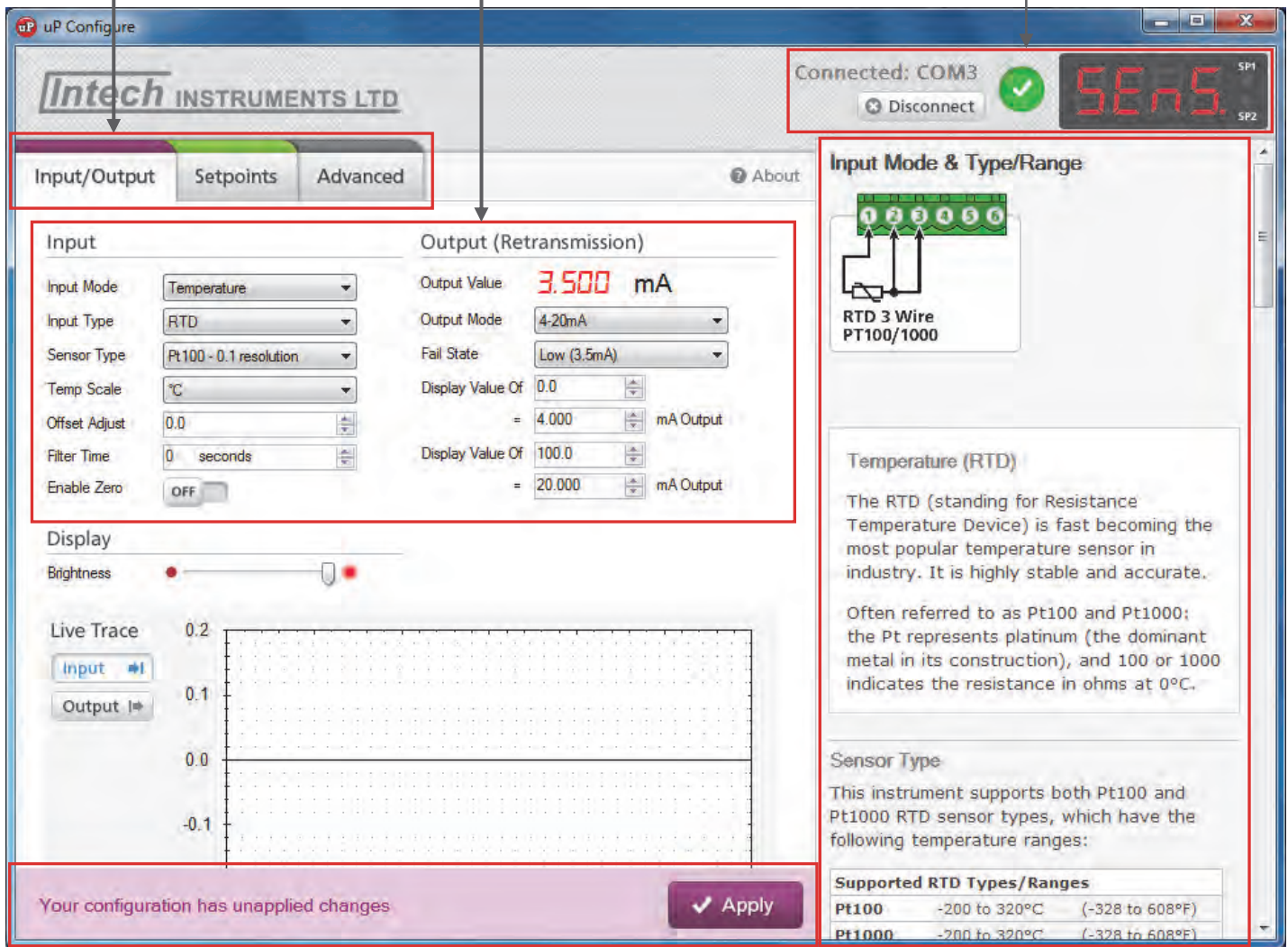

Apply Bar.
Appears if you have made any changes in the **Control Area**. uP Configure will not allow you to browse to a new tab in the **Main Navigation** with unapplied changes to your configuration.

Help Panel.
Diagrams, explanations and helpful tips will automatically appear in this panel as you configure your uP4-Din.

Input & Output Connection Diagrams.

Universal Analogue Input Wiring.

The input terminal can be wired to suit many different input types as per the specifications on pages 4 and 5.

BEFORE YOU BEGIN WIRING:

1. Ensure that all programming is carried out **BEFORE** any wiring takes place!
2. Ensure that the power supply is disconnected. Refer to the diagram on page 6 for terminal location and numbering.

Voltage Input.

±200mVdc.

For low signal applications the uP4-Din supports a ±200mVdc range. Typical applications include measuring large DC currents using external current shunts.

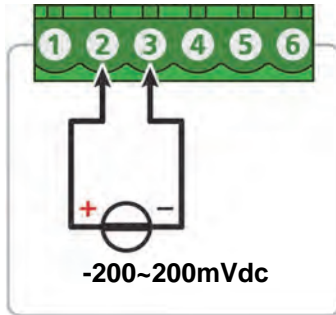

-200mV~1Vdc.

A -200mV to 1Vdc range is provided for interfacing to sensors and other electronic apparatus that provide this output.

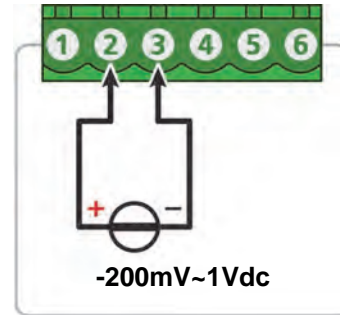

0~10Vdc.

0 to 10Vdc is a common process signal generated by transmitters, meters and PLCs. It would normally be scaled into engineering units by the uP4-Din.

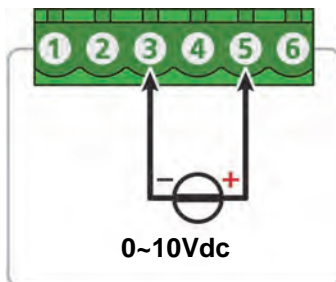

±10Vdc.

±10Vdc is a common process signal generated by transmitters, meters and PLCs. It would normally be scaled into engineering units by the uP4-Din.

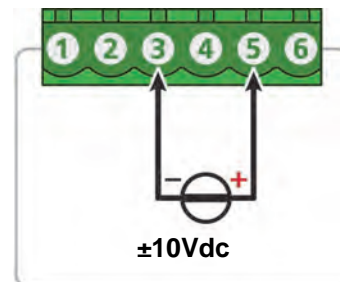

0~10V or ±10Vdc, 3 or 4 wire transmitter.

The uP4-Din can provide up to 25mA to power an external 3 or 4 wire transmitter, and at the same time measure the 0~10V or ±10V DC output signal.

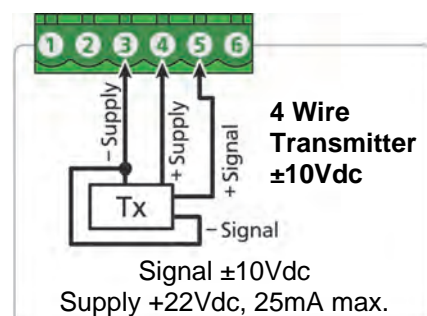
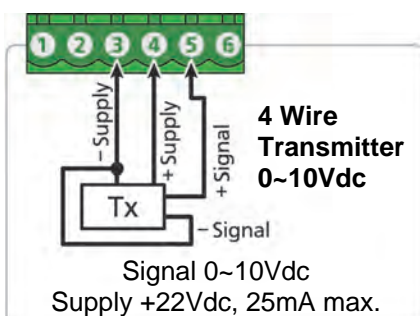
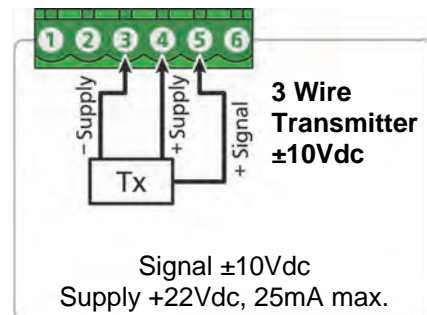
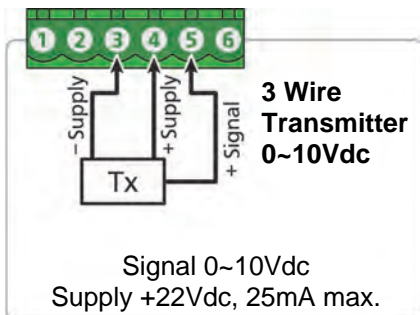

-10~30Vdc

This range is a general purpose voltage measuring range and would be typically used to measure battery voltages, power supply outputs, etc.

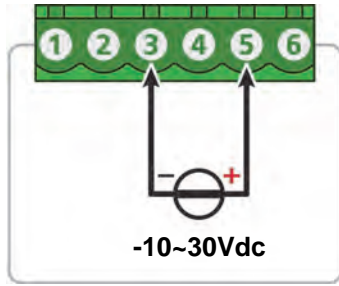

0~300Vdc

This higher voltage general purpose range is typically used to measure battery voltages, power supply outputs, etc.

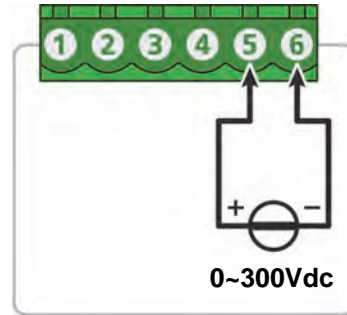

Caution - Risk of electric shock

Exercise extreme caution when handling high voltage inputs.



Caution

Rated voltage between pins 5 & 6 and earth is 300Vdc max.

Current Input.

0/4~20mA

0/4~20mA is the most commonly used analogue signal in the industry, and is universally accepted. As a current loop, it is unaffected by voltage drops in cables and can be transmitted over long distances without signal degradation.

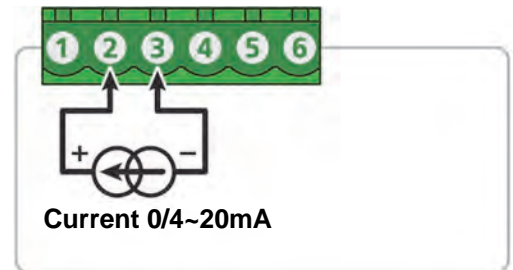

Sensor Power Supply:

The uP4-Din also has a transmitter power supply feature. The power supply will provide +22Vdc, 25mA max. The transmitter power supply is designed to power a field transmitter as the following drawings demonstrate:

2 Wire 4~20mA Loop Powered Transmitter

The uP4-Din connected to a 2 Wire 4~20mA Loop Powered Transmitter.

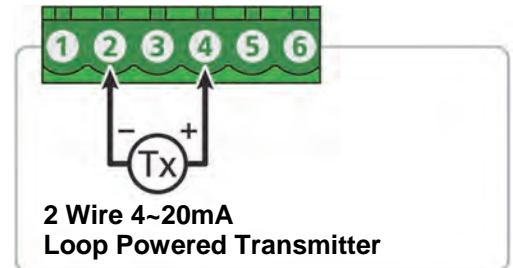

3 or 4 Wire 0/4~20mA, Transmitter

The uP4-Din can provide up to 25mA to power an external 3 or 4 wire transmitter, and at the same time measure the 4~20mA signal.

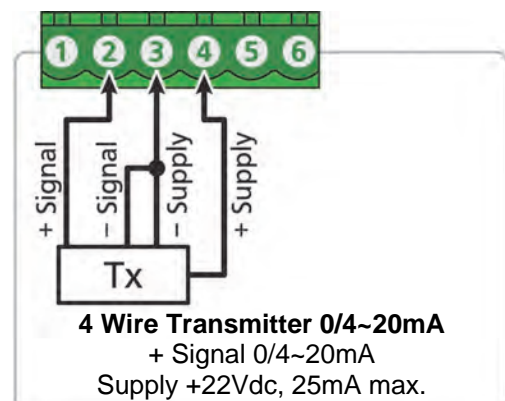
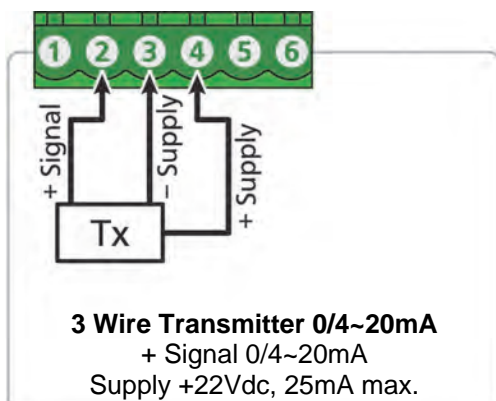

Note: Even if the uP4-Din is powered off, the loop current connection is maintained.

Thermocouple Input.

The thermocouple is one of the most common temperature sensors used in industry. It relies on the Seebeck coefficient between dissimilar metals. The thermocouple type is selected with reference to the application temperature range and environment.

Supported Thermocouple Types and Ranges.		
B	0°C	+1820°C
E	-100°C	+1000°C
J	-200°C	+1000°C
K	-200°C	+1372°C
N	-180°C	+1300°C
R	-50°C	+1760°C
S	-50°C	+1760°C
T	-200°C	+400°C

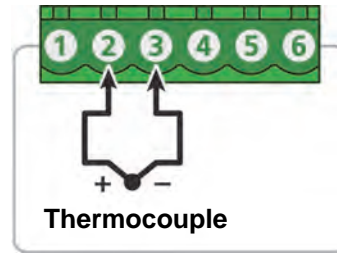

RTD Input.

The RTD (standing for Resistance Temperature Device) is highly stable and accurate and is fast becoming the most popular temperature sensor in industry. Often referred to as **Pt100** and **Pt1000**, the Pt represents platinum (the dominant metal in its construction), and 100/1000 is the resistance in ohms at 0°C.

Supported RTD types/ranges		
Pt100	-200°C	+320°C
Pt1000	-200°C	+320°C

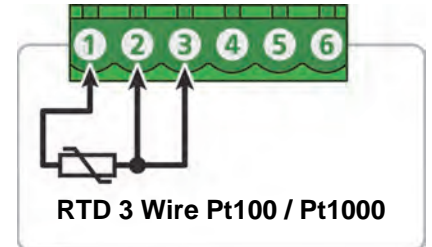
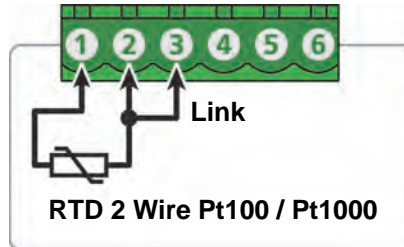

NTC Input.

NTC (Negative Temperature Coefficient), is a particular type of thermistor. NTC's are popular in the HVAC industry due to their low cost, but have a limited temperature range which makes them less popular in general industry. The biggest issue with their general acceptance is that there is no standard that covers interoperability between different thermistor manufacturers.

Supported NTC types/ranges		
10K (Beta 3984)	-55°C	+125°C
10K (Beta 3435)	-50°C	+110°C

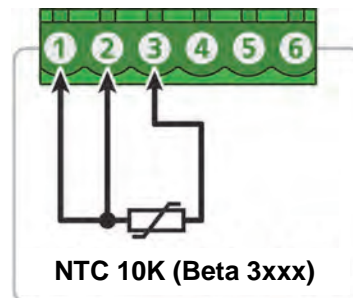

Potentiometer Input.

A 3 wire potentiometer is typically used to measure position. The low, medium or high potentiometer range can be programmed to your unit using the uP Configure software. These ranges must be calibrated using the two point calibration method.

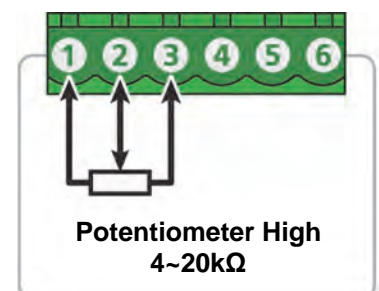
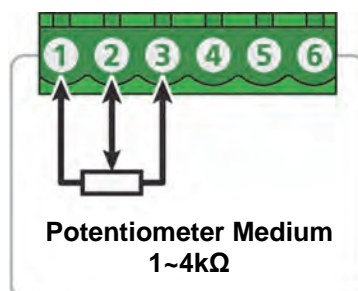
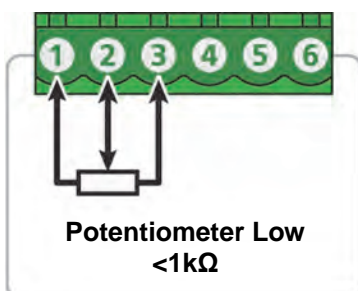

Pulse & Frequency Input.

General Frequency mode

General Frequency mode allows an NPN or PNP input (up to 2KHz) to be measured and scaled to any engineering unit. The uP4-Din can also provide up to 25mA to power an external device.

Flow rate mode

Flow Rate mode enables an input from an NPN or PNP paddle type flow meter to be converted to a flow rate. The input signal (up to 2KHz) is converted into a flow rate by programming the unit with the sensor manufacturer's K-factor value. The uP4-Din can also provide up to 25mA to power a 3 wire NPN paddle type flow sensor.

RPM mode

RPM mode enables an input from an NPN or PNP proximity sensor to be converted to an RPM (Revs Per Minute) value. The input signal (up to 2KHz) is converted into RPM by programming the unit with the pulses per revolution value. The uP4-Din can also provide up to 25mA to power a 3 wire NPN proximity sensor.

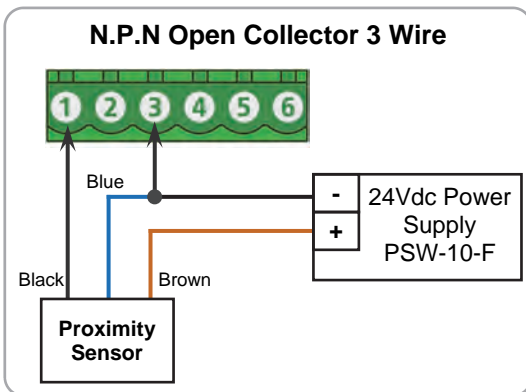
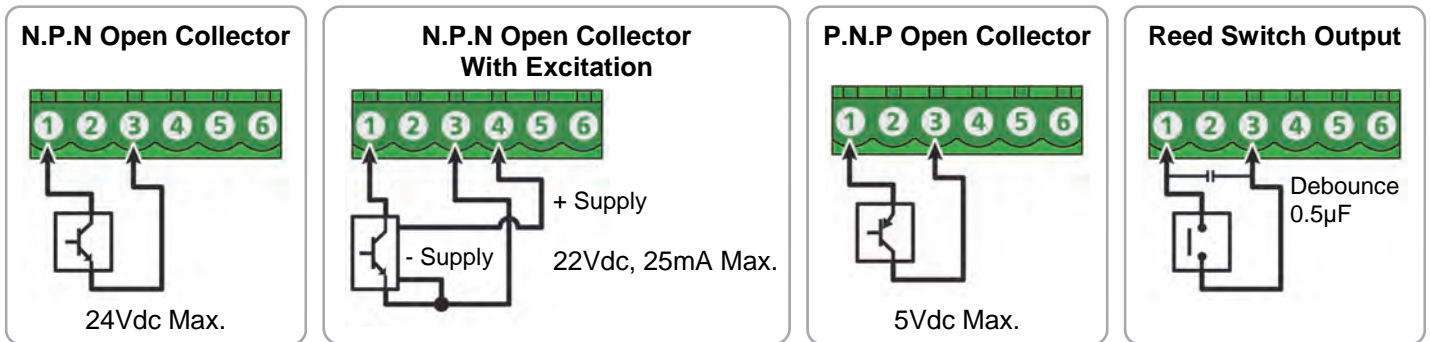

Note: P.N.P Open Collector 3 Wire is NOT supported.

Analogue Output - uP4-Din-R2A only.

Terminal pins 14~17, also see page 6.

For analogue output with the uP4-Din, wire as shown (right).

The analogue output can be scaled to suit your application using the uP Configure software under the Input/Output tab.

E.g. Output (Retransmission)

Output Value	3.500 mA
Output Mode	4-20mA
Fail State	Low (3.5mA)
Display Value Of	0.0
=	4.000 mA Output
Display Value Of	100.0
=	20.000 mA Output

This means that when the uP4-Din display shows the value of 0.0, the retransmission output will be at 4mA, and when the display shows the value of 100.0, the retransmission output will be at 20mA.

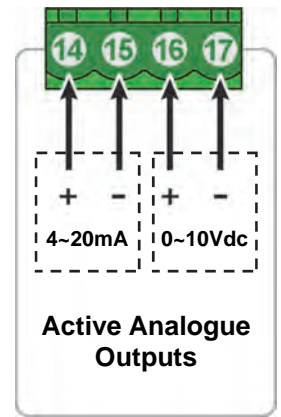

Relay Outputs.

Terminal pins 9~13, also see page 6.

For relay outputs with the uP4-Din, wire them as shown (right).

The relay setpoints can be configured using uP Configure software for a variety of alarm or control functions.

The manual relay reset switch (terminal pins 18~19) can be used to force the alarm out of alarm state manually. It is also an option for a latched alarm reset action.

The relay reset switch options are selectable under the Setpoints tab of the uP Configure software.

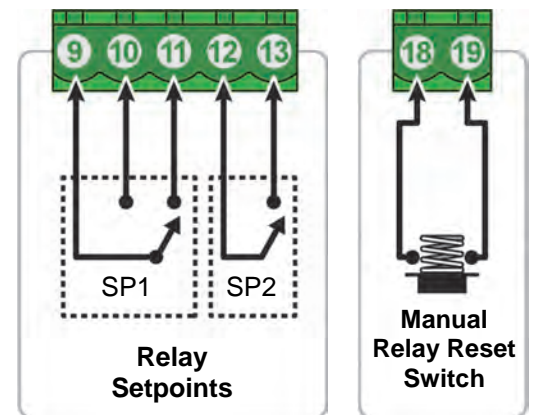

Universal Power Supply.

Terminal pins 7~8, also see page 6.

The uP4-Din accepts a wide power supply range that suits both mains AC voltage and 24Vdc applications (24~250Vac / 19.5~250Vdc). The power supply input has been designed so that a DC polarity may be connected either way around.

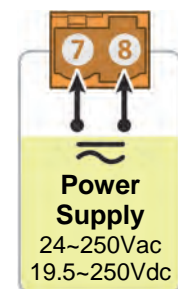

uP4-Din Wiring, Installation and Maintenance.

THE uP4-Din IS TO BE INSTALLED AND SERVICED BY SERVICE PERSONNEL ONLY. NO OPERATOR / USER SERVICEABLE PARTS.

BEFORE YOU BEGIN WIRING: Ensure that all programming is carried out BEFORE any wiring takes place! All power and signals must be de-energised BEFORE connecting any wiring.

uP4-Din Wiring & Installation.

Mounting:

* Also refer to Connection Diagrams and Notes (Pages 6 & 7).

- 1) Mount so the terminals are in a clean environment behind the panel.
- 2) Minimum clearance behind the panel is to be no less than 80mm.
- 3) Do not subject to vibration or excess temperature or humidity variations.
- 4) Avoid mounting in cabinets with power control equipment.
- 5) Allow 10mm minimum clearance between the uP4-Din terminals and ANY conductive material.

Analogue Signal Wiring:

- 1) All signal cables should be good quality overall screened INSTRUMENTATION CABLE with the screen earthed at one end only.
- 2) Signal cables should be laid a minimum distance of 300mm from any power cables.
- 3) For 2 wire current loops, 2 wire voltage signals or 2 wire current signals, B5102ES is recommended. For 3 wire transmitters and RTDs, B5103ES is recommended.
- 4) It is recommended that you do not ground analogue signals and use power supplies with ungrounded outputs.
- 5) Lightning arrestors should be used when there is a danger from this source.
- 6) Refer to diagrams for connection information.

Thermocouple Extension Wire:

- 1) Use the correct thermocouple extension or compensation cable. i.e. Thermocouple type, insulation type, correct colour coding.
- 2) It is recommended to install extension or compensation cable in a grounded conduit by themselves, or use overall screened cable with the screen earthed at one end only. Never run electrical wires in the same conduit.
- 3) All wires that must be spliced should be soldered, or a proper thermocouple termination block used.
- 4) Lightning arrestors should be used if there is a chance from this source.

Thermocouples:

- 1) Avoid locating the thermocouple where it will be in a direct flame.
- 2) Never insert a porcelain or refractory tube suddenly in a hot area. Pre-heat gradually while installing.
- 3) Locate it where the average temperature will be measured. It should be representative of the mass. If necessary use several thermocouples to obtain the average temperature.
- 4) Immerse the thermocouple far enough so that the measuring junction is entirely in the temperature to be measured: nine to ten times the diameter of the protection tube is recommended. Heat conducted away from the junction causes an error in reading.
- 5) If the thermocouple is mounted horizontally and the temperature is above the softening point of the tube, a support should be provided to prevent the tube sagging. Otherwise install the tube vertically.
- 6) Keep the junction head and cold junction in the approximation of the ambient temperature. Especially in the Noble Metal Class.

RTDs:

- 1) Avoid locating the RTD where it will be in a direct flame.
- 2) Locate it where the average temperature will be measured. It should be representative of the mass.
- 3) Immerse the RTD far enough so that the measuring point is entirely in the temperature to be measured; nine to ten times the diameter of the protection tube is recommended. Heat that is conducted away from the measuring point causes an error in reading.

Power Supply Wiring:

- 1) Use Only Instrument Quality Power Supplies.
- 2) A readily accessible disconnect device and a 1A, 250Vac overcurrent device, must be in the power supply wiring.

uP4-Din Commissioning.

- 1) **WARNING: Ensure that all programming is carried out BEFORE any wiring takes place!**
- 2) Check that the uP4-Din has been set to the correct input ranges and all functions such as Upscale/Downscale Drive etc. Observe polarity and the correct terminal connections for wiring correctly. Only use certified calibration equipment. For Thermocouple calibration place the uP4-Din and calibration equipment directly next to each other, in still air, with no direct sunshine. Allow the CJC junctions to equalise in temperature before commencing calibration. Lower temperature ranges are affected more by the CJC Junction (allow more time to equalise).

- 3) Once the above conditions have been met and the wiring checked, apply power to the uP4-Din and the loops and/or sensors. Allow at least a 5 minute warm-up period.
- 4) **Thermocouple Inputs only:** Due to the limits of error in a standard Thermocouple probe, and standard extension wire and compensating wire, an error can occur. E.g. In a type K Thermocouple installation an error of 2.2°C or 0.75% FSO can occur (whichever is greater).
The uP4-Din has an integral CJC sensor, the enclosure must be assembled and installed where it avoids drafts and temperature differences across terminals. Once installation is complete, close the cabinet door and allow the cabinet to reach equilibrium. This may take several hours. Place all the Thermocouple probes into a calibrated thermal bath at the temperature of interest or use a calibration standard Thermocouple at the same immersion depth and temperature of interest and adjust the Zero until the two temperatures agree.
- 5) **Calibration Check:** Take a reading of the value being measured on the input, and ensure that this agrees with the level being indicated by the uP4-Din display. Adjust for any differences. It is recommended to measure both a high and low value and compare these readings with your calibration device.

uP4-Din Maintenance.

DC Voltage and Current Inputs:

- 1) Check the Sensor or Transducer supplying the signal to the uP4-Din for wear or damage and replace if defective.
- 2) Check the cables connected to the Sensor or Transducer.
- 3) Repeat (5) of commissioning. Do it regularly - at least once per year.

Thermocouple Inputs:

- 1) Replace defective protection tubes - even if they look good they may not be air or gas tight.
- 2) Check extension and compensating cable circuits, especially cables entering the Thermocouple sensor head.
- 3) Do not use the same Chromel-Alumel (Type K) Thermocouple below 540°C if it was used above 860°C.
- 4) Repeat (5) of commissioning. Do it regularly - at least once per year.

RTD Inputs:

- 1) Replace defective protection tubes - even if they look good they may not be air or gas tight.
- 2) Check cables entering the RTD sensor head.
- 3) Repeat (5) of commissioning. Do it regularly - at least once per year.

Troubleshooting.

Problem	Resolution
No Display	Check power Connections.
C,Err	Internal Comms Error. Try re-starting unit. If the problem is intermittent, this error could be caused by an EMC issue. Please refer to 'Mounting' and 'Power Supply Wiring' (page 15) for potential remedies.
Er,CL	Analogue Output Calibration Error. Factory calibration of analogue output is corrupt or missing. Return unit to Intech for re-calibration.
ErFI	Display Flash Error. Settings such as decimal point, scaling, and brightness will be lost. Reconnect to uP Configure and set up the unit again.
Er,01 to 10	Analogue Input Error. Error type indicated by a numerical error code (01-10). Please return to Intech for repair.
SEnS	Sensor Error. Sensor is missing or faulty. Check your sensor wiring. <i>Normal during initial programming.</i>
oUEr	A/D Overflow. Check your sensor wiring. If the sensor wiring is correct, check the signal level.
undr	A/D Underflow. Check your sensor wiring. If the sensor wiring is correct, check the signal level.

Intech INSTRUMENTS LTD
www.intech.co.nz
Christchurch Ph: +64 3 343 0646
Auckland Ph: 09 827 1930
Email: sales@intech.co.nz