

PI-B Programmable Isolating Bridge Transmitter.

Programmable Isolating mV Bridge
Input to DC Current or
DC Voltage Output Transmitter.

Features.

- Field Programmable Input and Output Ranges.
- Bi-Polar Input and Output Ranges.
- Input to Output Isolation 1.6kV.
- High Accuracy 0.1%.
- Universal AC/DC Power Supply.
- Selectable 3 Second Input Damping.
- High Precision 10Vdc Bridge Power Supply.
- Compact DIN Rail Mount Enclosure.
- Available Standard or Special Calibration.



Z495

Other PI- models include:
PI-B Bridge / Strain gauge;
PI-D DC; mA, mV, V.
PI-F Frequency;
PI-K Resistance;
PI-M Maths Computing;
PI-N RTD Differential Pt100;
PI-P Potentiometer;
PI-R RTD Pt100;
PI-S Relay Dual Setpoint;
PI-T Thermocouple.

Ordering Information.

PI-B-X Standard Calibration: Input 0~20mV; Output 4~20mA;
High Voltage Power Supply.

PI-B - - - - Special Range Special Range Calibration.
IR OR PS

INPUT RANGES				OUTPUT RANGES			
mV	IR	mV	IR	Voltage	OR	Current	OR
0~1mV	1	0~200mV	21	0~500mV	A	0~1mA	1
0~2mV	2	0~500mV	22	0~1V	B	0~2mA	2
0~3mV	3	0~750mV	23	0~2V	C	0~5mA	3
0~4mV	4	0~1000mV	24	0~3V	D	0~10mA	4
0~5mV	5	2~6mV	25	0~4V	E	0~16mA	5
0~6mV	6	5~10mV	26	0~5V	F	0~20mA	6
0~8mV	7	15~20mV	27	0~6V	G	1~5mA	7
0~10mV	8	30~35mV	28	0~8V	H	2~10mA	8
0~12mV	9	30~40mV	29	0~10V	I	4~20mA	9
0~15mV	10	30~45mV	30	0~12V	J	-1~1mA	10
0~20mV	11	30~60mV	31	1~5V	K	-2~2mA	11
0~25mV	12	50~80mV	32	2~10V	L	-5~5mA	12
0~30mV	13	100~200mV	33	-1~1V	M	-10~10mA	13
0~35mV	14	-2~4mV	34	-2~2V	N	-20~20mA	14
0~40mV	15	-4~6mV	35	-5~5V	O		
0~50mV	16	-5~7mV	36	-10~10V	P		
0~60mV	17	-10~20mV	37	-12~12V	Q		
0~75mV	18	-50~70mV	38				
0~80mV	19	-100~300mV	39				
0~100mV	20	-200~800mV	40				
Special Input Range			Z	Special Output Range			Z

POWER SUPPLY	PS
High Voltage Power Supply: 85~264Vac/dc	H
Mid Voltage Power Supply: 22~85Vac/dc	M
Low Voltage Power Supply: 10~28Vac/dc	L

Note: Power supply H is field selectable for M, and M for H. Power supply L must be ordered separately.

Ordering Examples.

- 1/ PI-B-8-1-L 0~10mV Input; 0~1mA Output; Low Voltage Power Supply
- 2/ PI-B-Z-P-H-0~18mV 0~18mV Input; -10~10V Output; High Voltage Power Supply

Quality Assurance Programme.

The modern technology and strict procedures of the ISO9001 Quality Assurance Programme applied during design, development, production and final inspection grant the long term reliability of the instrument.

PI-B Rev2 Specifications.

Input	-MilliVolts	Field Programmable From 1mVdc to 1000mVdc and Bipolar. Minimum Input Resistance = 1MΩ.
		Maximum Over-range = 30Vdc Continuous.
		3 Second Input Damping Selectable with S5-1.
	-Bridge P/S	10Vdc±0.1%. Max Load = 30mA. Ripple < 10mV Typical at 30mA Load.
Output	-Voltage	Field Programmable From 500mVdc to ±12Vdc.
	-Current	Maximum Output Drive = 10mA. Field Programmable From 1mAdc to ±20mAdc. Maximum Output Drive = 10Vdc. (500Ω @ 20mA.)
Power	-H	85~264Vac/dc; 50/60Hz; 5VA.
	-M	22~85Vac/dc; 50/60Hz; 5VA. 32Vac Min. When Using 10V Bridge P/S.
	-L	10~28Vac/dc; 50/60Hz; 5VA.
	-Circuit Sensitivity	<±0.001%/V FSO Typical.
	Accurate to	<±0.1% FSO Typical.
	Linearity & Repeatability	<±0.1% FSO Typical.
	Ambient Drift	<±0.01%/C FSO Typical.
	Noise Immunity	125dB CMRR Average. (1600Vdc Limit.)
	EMC Compliances	Emissions EN 55022-A. Immunity EN 50082-1, <1% Effect FSO Typical.
	Safety Compliance	EN 60950
	Mains Isolation	250Vac.
	Isolation Test Voltages	Mains to Input/Output 3kVac 50Hz for 1min; Input to Output 1.6kVdc for 1min.
	Response Time	200msec Typical. (10 to 90% 50msec Typical.)
	Operating Temperature & Humidity	0~60C. (Storage Temp. -20~80C.) 5~85% RH Max. Non-Condensing.
	Dimensions and Mounting	L=80, W=50, H=120mm. Mounts on 35mm Symmetrical Mounting Rail.

Product Liability. This information describes our products. It does not constitute guaranteed properties and is not intended to affirm the suitability of a product for a particular application. Due to ongoing research and development, designs, specifications, and documentation are subject to change without notification. Regrettably, omissions and exceptions cannot be completely ruled out. No liability will be accepted for errors, omissions or amendments to this specification. Technical data are always specified by their average values and are based on Standard Calibration Units at 25C, unless otherwise specified. Each product is subject to the 'Conditions of Sale'.

Warning: These products are not designed for use in, and should not be used for patient connected applications. In any critical installation an independent fail-safe back-up system must always be implemented.

Examples of PI-B Input Connection.

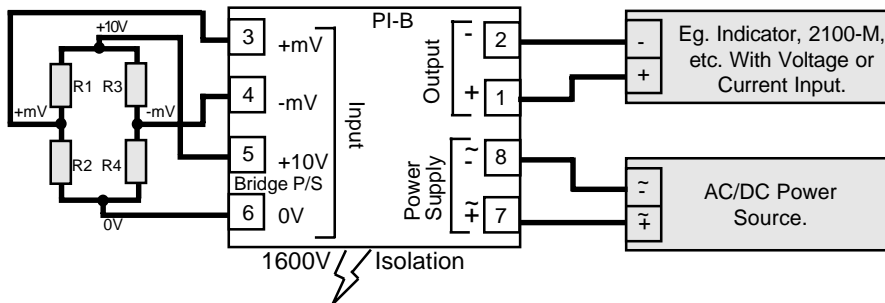

Terminations.

Output 1	+Ve
2	-Ve
Input 3	+mV
4	-mV
5	10V Bridge P/S
6	0V Bridge P/S
P/S 7	Neutral/+DC
8	Phase/-DC

Plan View of PI-B Adjustments.

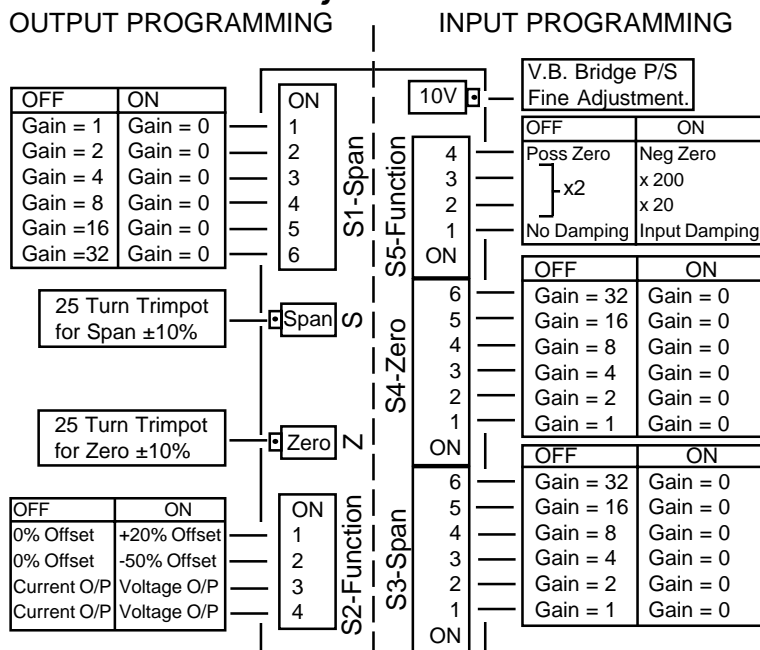

PI-B Dimensions and Mounting.

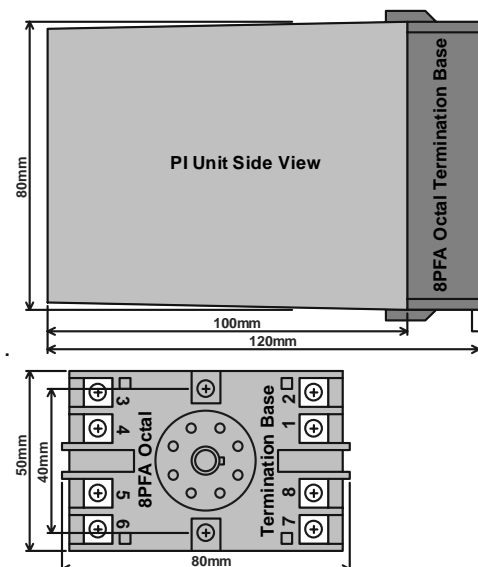

PI-B Input Programming.

Always set **OUTPUT range first**, then INPUT range.

If the input range is not listed in the programming table, use the following formulae to work out the Zero and Span DIP switch settings for gain.

$$\text{Span Gain} = \frac{60 \times \text{Pregain}}{(\text{Signal High} - \text{Signal Low})}$$

$$\text{Zero Gain} = \frac{5 \times \text{Signal Low}}{\text{Pregain}}$$

If Zero gain is: 1/ Positive, put S5-4 OFF.
2/ Negative, put S5-4 ON.

EFFECTIVE INPUT RANGE (i.e. Signal High - Signal Low.)	S5-2	S5-3	Pregain
1mV <= Range <= 10mV	0	0	1
10mV < Range <= 100mV	0	1	10
100mV < Range <= 1000mV	1	1	100

Gain Value	1	2	4	8	16	32
DIP Switch No.	1	2	3	4	5	6

So if a gain value of 28 is required, put DIP switch no's 3, 4, 5 OFF, (ie, gains of 4 + 8 + 16 = 28) and all the other DIP switches ON.
DIP switches and Pots are accessed by removing the small rectangular lid on the top of the PI-B enclosure.

- Notes: (a) Enter ranges as their mV value. eg. Enter 100mV as 100.
(b) Use the same pregain value in both the Span and Zero gain formulae.
(c) Enter the Zero or Span gain value into the appropriate Zero or Span DIP switch.
(d) If the ZERO GAIN exceeds 63, then the input range must be factory calibrated.

PI-B Input Range Programming Table.

- Notes: 1/ Switch status 1 = ON, 0 = OFF, X = DON'T CARE.
2/ Input ranges with "*" beside them require more adjustment with the Span trimpot.

INPUT RANGE	S3-Span						S4-Zero						S5-Function			
	1	2	3	4	5	6	1	2	3	4	5	6	1	2	3	4
0~1mV	1	1	0	0	0	0	1	1	1	1	1	1	0	0	0	x
0~2mV	1	0	0	0	0	1	1	1	1	1	1	1	0	0	0	x
0~3mV	1	1	0	1	0	1	1	1	1	1	1	1	0	0	0	x
0~4mV	0	0	0	0	1	1	1	1	1	1	1	1	0	0	0	x
0~5mV	1	1	0	0	1	1	1	1	1	1	1	1	0	0	0	x
0~6mV	1	0	1	0	1	1	1	1	1	1	1	1	0	0	0	x
0~8mV*	1	1	1	0	1	1	1	1	1	1	1	1	0	0	0	x
0~10mV	1	0	0	1	1	1	1	1	1	1	1	1	0	0	0	x
0~12mV	1	0	1	1	0	0	1	1	1	1	1	1	0	1	0	x
0~15mV	1	1	1	0	1	0	1	1	1	1	1	1	0	1	0	x
0~20mV	1	0	0	0	0	1	1	1	1	1	1	1	0	1	0	x
0~25mV	1	1	1	0	0	1	1	1	1	1	1	1	0	1	0	x
0~30mV	1	1	0	1	0	1	1	1	1	1	1	1	0	1	0	x
0~35mV	0	1	1	1	0	1	1	1	1	1	1	1	0	1	0	x
0~40mV	0	0	0	0	1	1	1	1	1	1	1	1	0	1	0	x
0~50mV	1	1	0	0	1	1	1	1	1	1	1	1	0	1	0	x
0~60mV	1	0	1	0	1	1	1	1	1	1	1	1	0	1	0	x
0~75mV	1	1	1	0	1	1	1	1	1	1	1	1	0	1	0	x
0~80mV*	1	1	1	0	1	1	1	1	1	1	1	1	0	1	0	x
0~100mV	1	0	0	1	1	1	1	1	1	1	1	1	0	1	0	x
0~200mV	1	0	0	0	0	1	1	1	1	1	1	1	1	1	0	x
0~500mV	1	1	0	0	1	1	1	1	1	1	1	1	1	1	0	x
0~750mV	1	1	1	0	1	1	1	1	1	1	1	1	1	1	0	x
0~1000mV	1	0	0	1	1	1	1	1	1	1	1	1	1	1	0	x
2~6mV	0	0	0	0	1	1	1	0	1	0	1	1	0	0	0	0
5~10mV	1	1	0	0	1	1	0	1	1	0	0	1	0	0	0	0
10~15mV	1	1	0	0	1	1	1	0	1	1	0	0	0	0	0	0
10~20mV	1	0	0	1	1	1	1	0	1	1	0	0	0	0	0	0
10~30mV	1	0	0	0	0	1	0	1	0	1	1	1	0	1	0	0
30~45mV	1	1	1	0	1	0	0	0	0	0	1	1	0	1	0	0
30~60mV	1	1	0	1	0	1	0	0	0	0	1	1	0	1	0	0
50~80mV	1	1	0	1	0	1	0	1	1	0	0	1	0	1	0	0
100~200mV	1	0	0	1	1	1	1	0	1	1	0	0	0	1	0	0
-2~4mV	1	0	1	0	1	1	1	0	1	0	1	1	0	0	1	1
-4~6mV	1	0	0	1	1	1	1	1	0	1	0	1	0	0	1	1
-6~6mV	1	0	1	1	0	0	0	0	1	1	1	1	0	1	1	1
-10~20mV	1	1	0	1	0	1	0	1	0	1	1	1	0	1	1	1
-60~60mV	1	0	1	1	0	0	0	0	1	1	1	1	1	1	1	1
-100~300mV	0	0	0	0	1	1	0	1	0	1	1	1	1	1	1	1
-200~800mV	1	0	0	1	1	1	1	0	1	0	1	1	1	1	1	1

SET TO 1 FOR 3 SECOND DAMPING. SET TO 0 FOR NO DAMPING.

PI-B H1 Power Supply Jumper Settings.



WARNING: High Voltages Maybe Present.
Only adjust jumper with power disconnected.

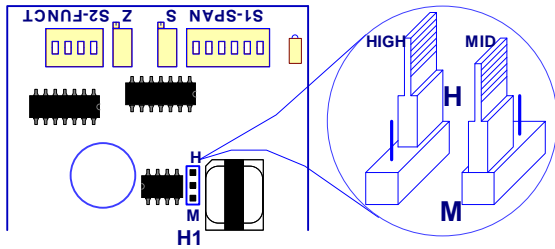

Power Supply Jumper Settings	
H1	Power Supply Voltage Range
H	Link for High: 85~264ac/dc
M	Link for Mid: 22~85Vac/dc

Notes:

- 1/ H1 is approx 4cm (1½") behind the 'S' trimpot.
- 2/ Exceeding voltage ranges may damage the unit.
- 3/ Ensure the enclosure label is correctly labelled for the jumper position.
- 4/ Adjust H1 jumper with a pair of needle nose pliers.
- 5/ Low Voltage Power Supply version is fixed, and has no jumper.
This must be ordered separately.

PI-B Output Range Programming Table.

Notes: 1/ Switch status 1 = ON 0 = OFF
2/ Output ranges with '*' beside them reverse the polarity of the output connections.

Output Range (V)	S1-SPAN						S2-Function				Output Range (I)	S1-SPAN						S2-Function			
	1	2	3	4	5	6	1	2	3	4		1	2	3	4	5	6	1	2	3	4
0~500mV	0	1	1	1	1	1	0	0	1	1	0~1mA	0	1	1	1	1	1	0	0	0	0
0~1V	1	0	1	1	1	1	0	0	1	1	0~2mA	1	0	1	1	1	1	0	0	0	0
0~2V	1	1	0	1	1	1	0	0	1	1	0~5mA	0	1	0	1	1	1	0	0	0	0
0~3V	1	0	0	1	1	1	0	0	1	1	0~10mA	1	0	1	0	1	1	0	0	0	0
0~4V	1	1	1	0	1	1	0	0	1	1	0~16mA	1	1	1	1	0	1	0	0	0	0
0~5V	1	0	1	0	1	1	0	0	1	1	0~20mA	1	1	0	1	0	1	0	0	0	0
0~6V	1	1	0	0	1	1	0	0	1	1	1~5mA	1	1	0	1	1	1	1	0	0	0
0~8V	1	1	1	1	0	1	0	0	1	1	2~10mA	1	1	1	0	1	1	1	0	0	0
0~10V	1	1	0	1	0	1	0	0	1	1	4~20mA	1	1	1	1	0	1	1	0	0	0
0~12V	1	1	1	0	0	1	0	0	1	1	-1~1mA	1	0	1	1	1	1	0	1	0	0
1~5V	1	1	1	0	1	1	1	0	1	1	-2~2mA	1	1	0	1	1	1	0	1	0	0
2~10V	1	1	1	1	0	1	1	0	1	1	-5~5mA	1	0	1	0	1	1	0	1	0	0
-1~1V	1	1	0	1	1	1	0	1	1	1	-10~10mA	1	1	0	1	0	1	0	1	0	0
-2~2V	1	1	1	0	1	1	0	1	1	1	-20~20mA	1	1	1	0	1	0	0	1	0	0
-5~5V	1	1	0	1	0	1	0	1	1	1	0~-10mA *	1	0	1	0	1	1	0	0	0	0
-10~10V	1	1	1	0	1	0	0	1	1	1	0~-20mA *	1	1	0	1	0	1	0	0	0	0
-12~12V	1	1	1	1	0	0	0	1	1	1											
0~-5V *	1	0	1	0	1	1	0	0	1	1											
0~-10V *	1	1	0	1	0	1	0	0	1	1											

The Proper Installation & Maintenance of PI-B.

Note. All power and signals must be de-energised before connecting any wiring, altering any jumpers or DIP switches, or inserting or removing the PI unit from it's base.

MOUNTING.

- (1) Mount in a clean environment in an electrical cabinet on 35mm Symmetrical mounting rail.
- (2) Draft holes must have minimum free air space of 20mm. Foreign matter must not enter or block draft holes.
- (3) Do not subject to vibration or excess temperature or humidity variations.
- (4) Avoid mounting in cabinets with power control equipment.
- (5) To maintain compliance with the EMC Directives the PI-B is to be mounted in a fully enclosed steel cabinet. The cabinet must be properly earthed, with appropriate input / output entry points and cabling.

WIRING.

- (1) A readily accessible disconnect device and a 1A, 250Vac overcurrent device, must be in the power supply wiring.
- (2) All cables should be good quality overall screened INSTRUMENTATION CABLE with the screen earthed at one end only.
- (3) Signal cables should be laid a minimum distance of 300mm from any power cables.
- (4) For 2 wire current loops, 2 wire voltage signals or 2 wire current signals, Austral Standard Cables B5102ES is recommended. For 3 wire transmitters Austral Standard Cables B5103ES is recommended.
- (5) It is recommended that you do not ground current loops and use power supplies with ungrounded outputs.
- (6) Lightning arrestors should be used when there is a danger from this source.
- (7) Refer to diagrams for connection information.

COMMISSIONING.

- (1) Once all the above conditions have been carried out and the wiring checked, apply power to the PI-B and allow five minutes for it to stabilize.
- (2) Take a low (approx 10%) and high (approx 90%) reading of the variable being measured by the transducer supplying the signal to the PI-B, and ensure that this agrees with the level being indicated by the PLC or indicator, etc, that the PI-B is connected into. Adjust for any difference using the Zero and Span Pots in the top of the PI-B enclosure with a small screw driver, until the two levels agree. (Clockwise to increase the output reading and anti-clockwise to decrease the output reading.)

MAINTENANCE.

- (1) Repeat (2) of COMMISSIONING.
- (2) Do it regularly - at least once every 12 months.

Intech INSTRUMENTS LTD
www.intech.co.nz
 Christchurch Ph: +64 3 343 0646
 Auckland Ph: 09 827 1930
 Email: sales@intech.co.nz