

# Z-2400-A2 Series

Wireless Data Links Using ZIGBEE®  
For Analogue and Digital Interface.



FCC ID  
2ACTT-1409

CE

  
E2180

## Installation Guide.

---

## Z-2400-A2 Wireless Node Installation Guide Index.

Description.	Page 3
Ordering Information.	Page 3
Specifications.	Page 4
<i>Analogue Input 1~2 Specifications.</i>	Page 4
<i>Digital Input 1~4 Specifications.</i>	Page 5
<i>Digital Output 3~4 Specifications.</i>	Page 5
<i>Relay Output 1~2 Specifications.</i>	Page 5
<i>Analogue Output 1~2 Specifications.</i>	Page 5
<i>General Specifications.</i>	Page 5
Physical Layout Z-2400-A2 Series.	Page 6
<i>Front Panel Connections and LEDs.</i>	Page 6
<i>Terminal Connections.</i>	Page 6
Diagnostic LEDs.	Page 7
<i>RF Signal Quality LED Indication.</i>	Page 7
<i>Output, Input and Repeater Node Network Status LED Definitions.</i>	Page 7
<i>Power and ZigBee Network LED Indication.</i>	Page 8
Z-2400-A2I Dip Switch Positions for Input to Output Installations.	Page 8
ZigBee Mesh ID.	Page 8
Programming the Z-2400-A2 Series.	Page 8
<i>uP Configure Software.</i>	Page 8
<i>Installing uP Configure.</i>	Page 8
<i>Z-2400-A2 USB Connection.</i>	Page 9
<i>Using the uP Configure Software - version 1.2.8.0 or later.</i>	Page 10
<i>Configuring the Z-2400-A2O.</i>	Page 10
<i>Configuring the Z-2400-A2I.</i>	Page 11
<i>Configuring the Z-2400-A2R.</i>	Page 13
Connecting up the Z-2400-A2 Series.	Page 13
<i>Z-2400-A2 Series Power Supply Connection.</i>	Page 13
<i>Z-2400-A2I Analogue Input Connections.</i>	Page 14
<i>Connecting RTDs to the Z-2400-A2I Analogue Inputs.</i>	Page 14
<i>Connecting Thermocouples to the Z-2400-A2I Analogue Inputs.</i>	Page 14
<i>Connecting Voltage Signals to the Z-2400-A2I Analogue Inputs.</i>	Page 15
<i>Connecting Current Signals to the Z-2400-A2I Analogue Inputs.</i>	Page 15
<i>Connecting Pulse, Frequency &amp; On/Off State Signals to the Z-2400-A2I Analogue Inputs.</i>	Page 15
<i>Z-2400-A2I &amp; Z-2400-A2O Digital Input/Output Connections.</i>	Page 16
<i>Connecting to the Z-2400-A2I &amp; Z-2400-A2O Relay Outputs.</i>	Page 16
<i>Connecting to the Z-2400-A2I &amp; Z-2400-A2O Digital Outputs.</i>	Page 17
<i>Connecting Pulse, Frequency &amp; On/Off State Signals to the Z-2400-A2I &amp; Z-2400-A2O Digital Inputs.</i>	Page 17
<i>Z-2400-A2O Current Loop Outputs.</i>	Page 18
Z-2400-A2 Series Wiring, Installation and Maintenance.	Page 18
<i>Z-2400-A2 Wiring and Installation.</i>	Page 18
<i>Z-2400-A2 Commissioning.</i>	Page 19
<i>Z-2400-A2 Maintenance.</i>	Page 19
Troubleshooting.	Page 20
Considerations & Limitations for Z-2400 Network Systems.	Page 20
Antenna Options for Z-2400 Wireless Series.	Page 20

ZigBee® is a registered trademark of the **ZigBee Alliance, Inc.**

**Product Liability.** This information describes our products. It does not constitute guaranteed properties and is not intended to affirm the suitability of a product for a particular application. Due to ongoing research and development, designs, specifications, and documentation are subject to change without notification. Regrettably, omissions and exceptions cannot be completely ruled out. No liability will be accepted for errors, omissions or amendments to this specification. Technical data are always specified by their average values and are based on Standard Calibration Units at 25°C, unless otherwise specified. Each product is subject to the 'Conditions of Sale'.

**Warning: These products are not designed for use in, and should not be used for patient connected applications. In any critical installation an independent fail-safe back-up system must always be implemented.**

# Z-2400-A2 Series

Wireless Modules For  
Analogue & Digital Signals.

## Description.

The Z-2400-A2 series of units support the communication of analogue and digital signals via a wireless link. The series consists of three separate wireless nodes for: Input, Output and Repeating, and does not require a computer to monitor the wireless network. Built on the ZigBee® protocol, this allows for multiple Z-2400-A2 wireless links to operate side by side at the same time.

The Output node is the base and acts as the master for the entire link. The Input node acts as a wireless remote station and seeks for the Output Base to transmit the input signals to. The Repeater node is the bridge between the Input and Output wireless nodes, and is only used when the distance between them is too large to communicate directly.



FCC ID 2ACTT-1409 CE R-NZ E2180

## Ordering Information.

- **Z-2400-A2IO** One Wireless Output node and One Input node Paired & supplied as a Kit:
  - ⇒ **Z-2400-A2O** Output Base Wireless node. 2x 4~20mA Outputs, 4x Digital I/O.
  - ⇒ **Z-2400-A2I** Input Remote Wireless node. 2x Isolated Universal Inputs, 4x Digital I/O.
- **Z-2400-A2R** Repeater node for Wireless Extension.

Note: The Z-2400-A2 Series require the XU-USB Programming Key for Software Configuration:

<b>XU-USB (Rev 1):</b>	USB Programming Key for programming Z-2400-A2 Series using <b>uP Configure</b> Programming software. (Same Key as used for programming XU Series transmitters, 2400-A16, Z-2400-Sleeper, IN-uP4 and uP4-Din.)
------------------------	--

Note: For **ZA—Antenna Options** (used when greater distances are involved), see page 20 >>



### CAUTION

**Risk of electric shock.** Dangerous and lethal voltages may be present on the terminal of the device. Please take appropriate precautions to ensure safety.



### CAUTION

#### Risk of Danger.

For your safety, please read completely the instructions prior to installation and operation of the Z-2400-A2 Wireless Series. In particular, consult this manual in all cases where hazard symbols are marked on your Z-2400-A2I, Z-2400-A2O and Z-2400-A2R nodes, in order to understand and avoid potential hazards. The safety of any system incorporating these units is the responsibility of the assembler of the system.



### CAUTION

#### Observe minimum safe distance.

Intech Instruments Z-2400-A2 nodes comply with CFR47, Section 1.1307(b)(1). For your safety, please observe a minimum safe distance of 200mm.

**THE Z-2400-A2 NODES ARE TO BE INSTALLED AND SERVICED BY SERVICE PERSONNEL ONLY.  
NO OPERATOR / USER SERVICEABLE PARTS.**

## Specifications.

### Analogue Input 1~2 Specifications.

Input Resolution	16 Bits, 50,000 Steps Average (some ranges may differ).
Input Isolation	2500Vac for 1 minute between Inputs.
Sensor Break	RTDs & Thermocouples: Upscale. Broken Link or Other Input Types: Downscale.

### Voltage Input Specifications:

Input Impedance	>500K $\Omega$ on all ranges.
mV Maximum Over-range	3Vdc Continuous.
V Maximum Over-range	24Vdc Continuous.
mV Range	-200~200mV, -200~1000mV.
V Range	0~10V, 0~18V.
Accuracy	0.1% FSO Max.
Linearity and Repeatability	0.05% FSO Max.
Channel Separation	0.001% Max.
Ambient Drift	0.003%/°C FSO Typical.
Noise Immunity (CMRR)	160dB Tested @ 300Vrms 50Hz.
RF Immunity	1% effect FSO Typical.

### Current Input Specifications:

Minimum Recommended Span	0~1mA (gives 1000 steps on output).
Input Impedance	45 $\Omega$ .
Maximum Over-range	Protected by PTC Up to 24Vdc Max.
mA Range	0~20mA (4~20mA).
Accuracy	0.1% FSO Max.
Linearity and Repeatability	0.1% FSO Max.
Channel Separation	0.001% Max.
Ambient Drift	0.003%/°C FSO Typical.
Noise Immunity (CMRR)	160dB Tested @ 300Vrms 50Hz.
RF Immunity	1% effect FSO Typical.

### Thermocouple (T/C) Input Specifications:

Thermocouple Types	B, E, J, K, N, R, S, T.
Input Impedance	>500K $\Omega$ .
T/C Lead Resistance	100 $\Omega$ Max.
Cold Junction Compensation.	-10~60°C.
CJC Drift	0.02°C/°C For Installation Upright.
Accuracy	0.1% of FSO $\pm$ 1°C Typical.
Sensor Fail	Upscale or Downscale Selectable (Upscale Default).
Type B Range	0~1800°C (32~3272°F).
Type E Range	-200~700°C (-328~1292°F).
Type J Range	-200~1000°C (-328~1832°F).
Type K Range	-200~1260°C (-328~2300°F).
Type N Range	-200~1300°C (-328~2372°F).
Type R Range	0~1700°C (32~3092°F).
Type S Range	0~1700°C (32~3092°F).
Type T Range	-200~400°C (-328~752°F).

### RTD Input Specifications:

Pt100 RTD Type	3 Wire Pt100 RTD DIN 43760:1980 Standard Input.
Pt1000 RTD Type	3 Wire Pt1000 RTD Standard Input.
Sensor Current	0.6mA Continuous.
Lead Wire Resistance	Pt100: 10 $\Omega$ /wire Max. Pt1000: 5 $\Omega$ /wire Max.
	0.1% FSO Offset Error per $\Omega$ of Lead Resistance.
Sensor Fail	Upscale or Downscale Selectable (Upscale Default).
Ambient Drift	0.003°C/°C Typical.
Accuracy	0~300°C $\pm$ 0.1°C. 0~850°C $\pm$ 0.3°C.
Resolution	0.01°C for -200~250°C, (-140~210°F). 0.1°C for -200~850°C (-320~1560°F).

### Pulses & Frequency:

	Meter Pulses, Frequency, or On/Off State Inputs.
Input Type	Open Collector - NPN, PNP.
Frequency Range	0~2500Hz.
Frequency Resolution	0.1Hz.
Fast Counter Range	0~2500Hz.
Maximum Amplitude	0~5Vdc.
Debounce	0~50Hz Max.

### Digital Input 1~4 Specifications.

Frequency Range	0~1Hz.
Input Threshold	1.4Vdc.
Maximum Amplitude	30Vdc continuous.
Open Collector Excitation	3Vdc.
Isolation	Not isolated to the power supply common.

### Digital Output 3~4 Specifications.

Open-Drain, 30Vdc, 1A Max. (Not isolated to the power supply common.)

### Relay Output 1~2 Specifications.

Functions	2 on Board Controllers can be used as Set Point (SV), Switching Differential, Auto/Manual, Manual Output Setting, Dual Action Control, Single Action Control, Heat/Cool, Cool Only, Heat Only.
Relay Rating	Form A Relay, 250Vac/30Vdc, 5A Max.
Isolation to Sensor and Input Commons	2300Vrms for 1min. Working voltage 30Vdc.
Default State	Normally Open.
Approved to Standard	UL.

### Analogue Output 1~2 Specifications.

2 Isolated Analogue Outputs (not isolated from each other).

mA Range	4~20mA Loop Powered.
Resolution	15bit, 16000 steps.
Output Drive	700Ω Max @ 24Vdc Supply.
Linearity & Repeatability	0.1% FSO Max.
Accuracy	0.1% FSO.
Ambient Drift	50ppm/°C FSO Max.
Isolation to Digital I/O GND	1400Vrms for 1min. Working voltage 125Vdc.

### General Specifications.

#### Power:

Supply Voltage	9~36Vdc.
Consumption	2.5VA Max.
Isolation	1500Vac between power supply and input/output channels.

#### Environment:

Operating Temperature	-20~+55°C.
Storage Temperature	-20~+65°C.
Operating Humidity	0~85%.
Altitude	2000m.

#### Transmission:

RF Data Rate	250Kb/s.
RF Frequency	2405~2475MHz.
RF Channels	15.
RF Power	10mW or 100mW (User Selectable to comply with region wireless standards).
Spreading Method	Direct Sequence.
Modulation	O-QPSK.
Nodes	1 Output Base, 1 Input Remote, and up-to 15 Repeaters per mesh network max.
Antenna Connection	RP-SMA.
Tx Range	~4.0Km (supplied antenna line of sight, Reduces to 50m typical with major obstruction).
Tx Power	+10dBm or +20dBm (User Selectable to comply with region wireless standards).
Rx Sensitivity	-110dBm.
Connection Indication	Toggle LEDs.
Multiple Mesh Use	Mesh ID 0~255.
Default Mesh ID	1 (1, 2, 3, 4, 5, 6, 7, 8).
Link Connection Time	Time to Connect: Less than 1 Minute (No Repeater). Link Failure: 1 Minute.

#### Programming Port:

Programmable via XU-USB Key.

#### Compliances:

FCC Regulation	2ACTT-1409.
Radio Equipment and Systems	AS/ANS 4268:2012.
EMC Compliances	ETSI EN 300 440-2, V1.4.1, 2010. EN 301 489-3, V1.6.1, 2013.

#### Case:

35mm DIN Rail Mount.

Enclosure Rating	IP20.
Node Weight	Z-2400-A2I/A2O 0.15Kg, Z-2400-A2R 0.10Kg.
Dimensions (No Antenna)	H=104mm, W=24mm, D=120mm.

## Physical Layout Z-2400-A2 Series.

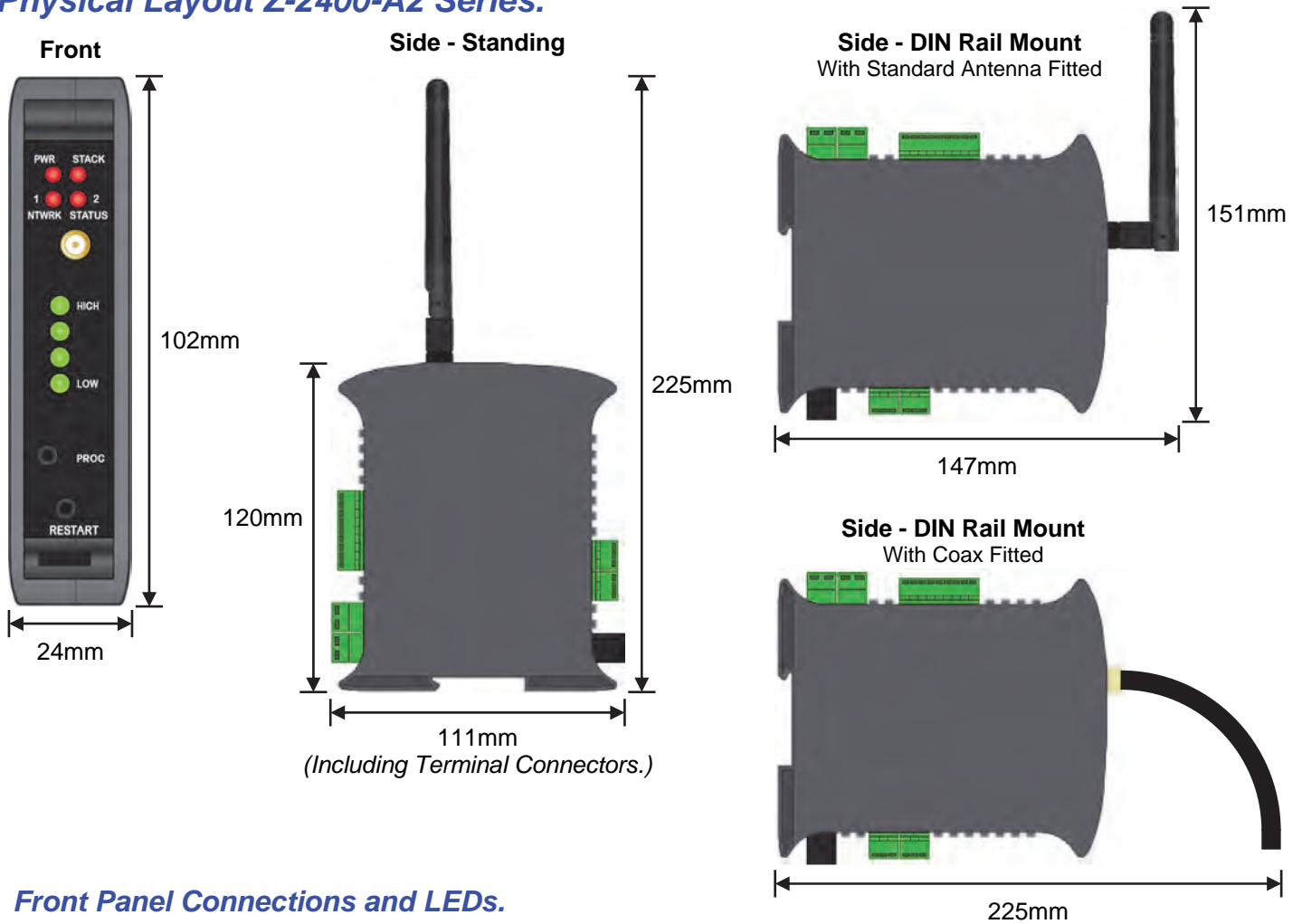

### Front Panel Connections and LEDs.

- Mounting:** 35mm DIN rail.
- LED indicators:** PWR - Power status.  
 STACK - Mesh network stack activity.  
 NTWRK STATUS - See *Diagnostic LEDs Tables* for more information.  
 HIGH / LOW - High to Low Link Quality to next wireless Z-2400-A2 Node.
- Aerial:** Screw in to attach. (*Additional High Gain Antennas Available.*)
- PROG:** USB input to program analogue inputs and digital inputs/outputs via XU-USB Programming Kit. (Software: **uP Configure** version 1.2.8.0 or later.)
- RESTART:** Button to reboot the Z-2400-A2 node.

### Terminal Connections.

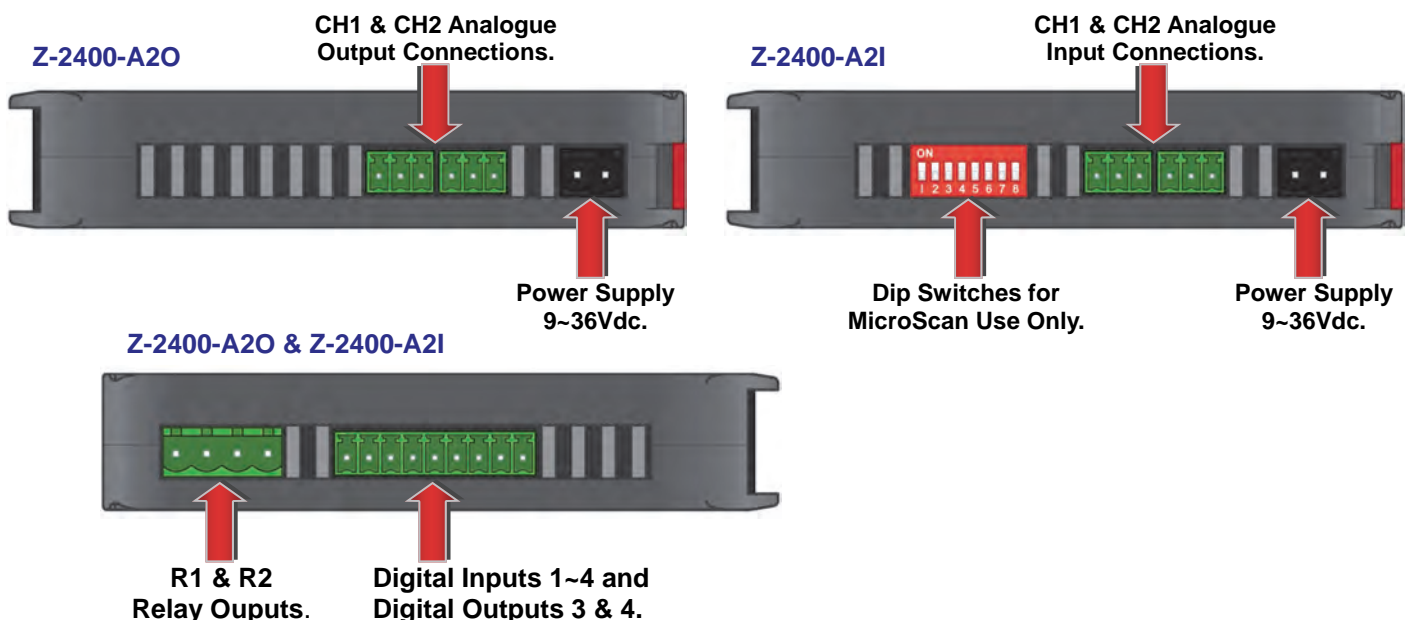

## Diagnostic LEDs.

### RF Signal Strength LED indication.

Each LED corresponds to the measured signal quality levels:

- One illuminated LED indicates very weak or no signal.
- Two illuminated LED's indicates low signal level.
- Three illuminated LED's indicates medium signal level.
- Four illuminated LED's indicate high signal level.

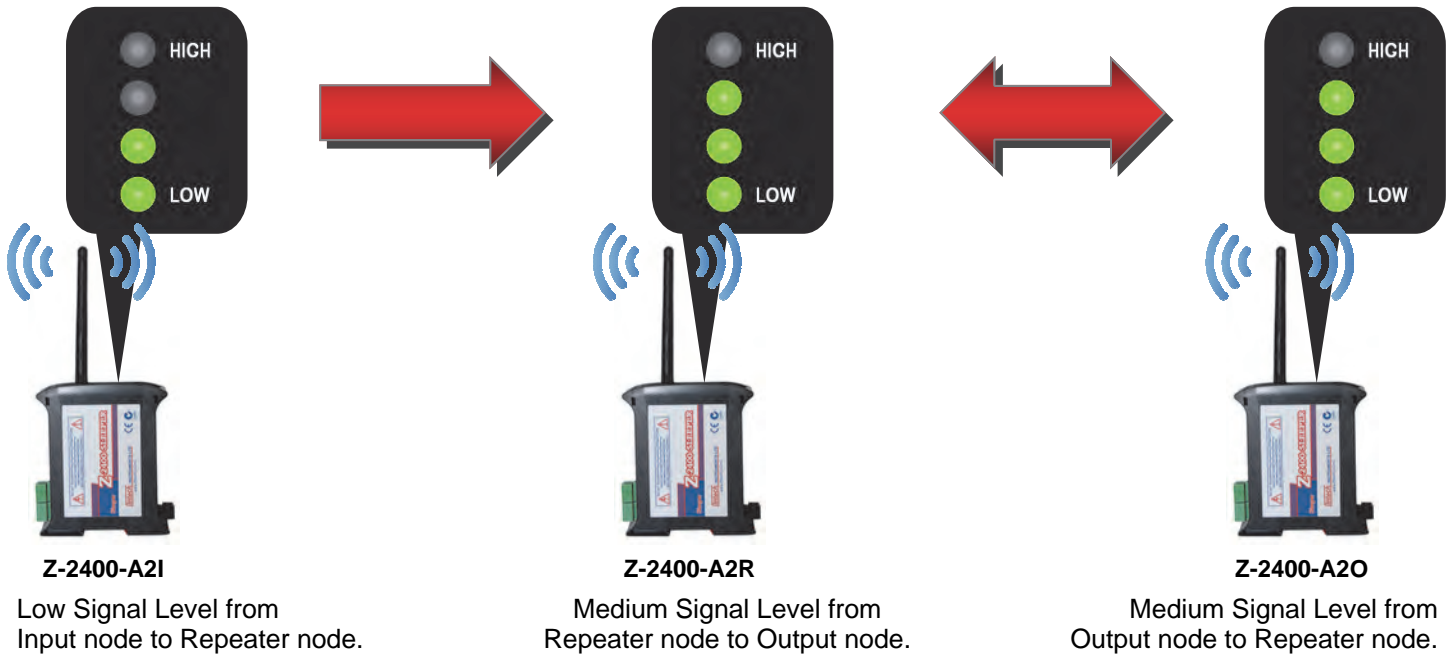

### Output, Input and Repeater Node Network Status LED Definitions.

	Z-2400-A2 node is not running.		Z-2400-A2 node is faulty.
	<b>Output</b> node is booting.		<b>Input / Repeater</b> node is booting.
	<b>Output</b> node is forming the network.		<b>Input / Repeater</b> node is searching for the network.
	<b>Output</b> node has reached maximum repeater node capacity in network.		<b>Input / Repeater</b> node can not detect the network.
	<b>Output</b> node has formed network and is ready to receive a transmission.		<b>Input / Repeater</b> node found the network and are ready to transmit.

OFF    ON    Flashing    Toggling

#### Output Network Status:

1 = ON, 2= OFF                      Output node starting up.  
1, 2 Toggle                              Network formed ready to connect.

#### Input Network Status:

2 = ON/Flashing, 1=OFF              Input / Repeater node starting up.  
1, 2 Toggle                              Input / Repeater node connected to network.  
1, 2 Flash at same time                Input / Repeater node NOT connected.  
(Output not running, or no signal getting through or wrong Mesh ID set.)

## Power and ZigBee Network LED indication.

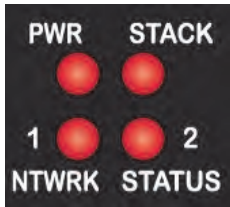

PWR	ON indicates power supplied connected.
STACK	Flashes when ZigBee® communication is active.
NTWRK STATUS 1, 2	See Previous table.

## Z-2400-A2I Dip Switch Positions for Input to Output Installations.

For the Input to Output Link (Z-2400-A2I to Z-2400-A2O), please check that the dip switch positions are exactly as shown, as any out of place switches will result in a wireless link failure.

The Z-2400-A2I can be configured via the dip switches on the side to work alongside Intech's other ZigBee® link, the Z-2400-RB or Z-2400-TCP base node, so that the analogue and digital input/outputs are communicating directly with MicroScan SCADA software. For this you can purchase the Z-2400-A2I as an individual unit.

Z-2400-A2IO Positions

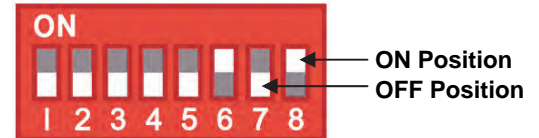

ON	6, 8
OFF	1~5, 7

## ZigBee Mesh ID.

The reason for Mesh IDs is to allow for multiple wireless Bases (Z-2400-A2O, Z-2400-RB & Z-2400-TCP) and therefore networks to be used in the same location where the Mesh signals will overlap. You can program the Mesh ID of the Repeater node via the 'uP Configure' software. The Input and Output nodes are supplied paired with a unique ID.

## Programming the Z-2400-A2 Series.

### uP Configure Software.



The 'uP Configure' software is free to download from Intech's website:  
[www.intech.co.nz/downloads](http://www.intech.co.nz/downloads)

**uP Configure** (version 1.2.8.0 or later) offers a smart, no-fuss setup experience for your Z-2400-A2 wireless nodes. It allows you to:

- Set up the analogue input types of the Z-2400-A2I (Default input is 4~20mA).
- Configure the digital inputs and outputs between Z-2400-A2I and Z-2400-A2O nodes.
- Set unique ZigBee Mesh ID networks to pair your Z-2400-A2 devices. (The Input and Output nodes are supplied paired to each other with a unique Mesh ID, however the Repeater will always need to be paired to the unique Mesh ID.)
- Configure the RF output to comply with the wireless standards of your region.

If you are programming the Z-2400-A2I for a MicroScan installation, then you must use 'XU Setup' software, refer to the 'Z-2400-A2I MicroScan Installation Guide'.

### Installing uP Configure.

**Note: You must install uP Configure before connecting a Z-2400-A2 wireless node to your computer. If you have already connected the wireless node using the XU-USB key, please disconnect it before continuing.**

1. Download the latest version of uP Configure from [www.intech.co.nz/downloads](http://www.intech.co.nz/downloads)  
For ease of access, we recommend saving the install file on your desktop. If you cannot locate the install file, check whether your browser has saved it in your Downloads folder.
2. Extract the install file from the zip folder. Right-click on the zip folder and choose 'Extract All', (or extract the file using another extraction utility of your choice).
3. Double-click on the extracted 'uPConfigure.msi' install file. This will launch the uP Configure installer. Depending on your security settings, a 'Security Warning' dialogue may appear. If you see the security message, click 'Run'. A Windows User Account Control window may also appear. Click 'Yes' to continue.



**Note:** uP Configure requires **Microsoft .NET 2.0** to be installed first. If .NET 2.0 is not already installed, a prompt will advise this so you can install online.

**Note:** An Administrator account or password will be required for installation. Contact your IT support for this if needed.

4. Follow the on screen instructions to complete the installation of uP Configure.

### Z-2400-A2 USB Connection.

To connect a Z-2400-A2 node to your PC requires the **XU-USB** Programming Key.  
(Same Key as used for programming XU Series transmitters, 2400-A16, Z-2400-Sleeper, IN-uP4 and uP4-Din.)

#### BEFORE YOU CONNECT:

- Ensure that you have a **XU-USB** Programming Key and a low voltage power supply (9~36Vdc).
- Install the uP Configure software before connecting the XU-USB to your computer (see page 8). uP Configure may not be able to detect your Z-2400-A2 node if it was already connected to your computer at the time of installation.
- Ensure that all programming is carried out **BEFORE** any input/output wiring takes place!

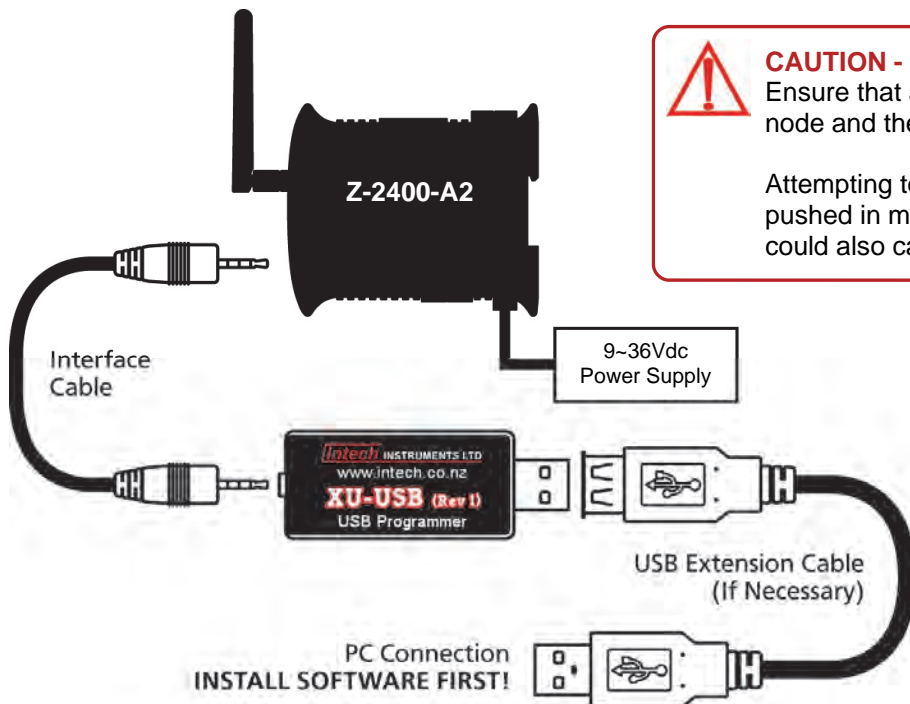

#### Connecting up:

- Connect the XU-USB key to your computer's USB port and the other end of the cable to the programming port on the Z-2400-A2 front panel (see page 6), ensuring that the cable between the XU-USB programming key and the Z-2400-A2 node are firmly 'pushed in'. Failure to do so could cause damage to your computer.
- Connect your Z-2400-A2 node to a low voltage power supply (9~36Vdc, Wiring diagram on page 13).
- Confirm the node is working by checking the 'PWR' LED is lit.

## Using the uP Configure Software - version 1.2.8.0 or later.

To run uP Configure, double click on the icon on your desktop.



### uP Configure Home Screen

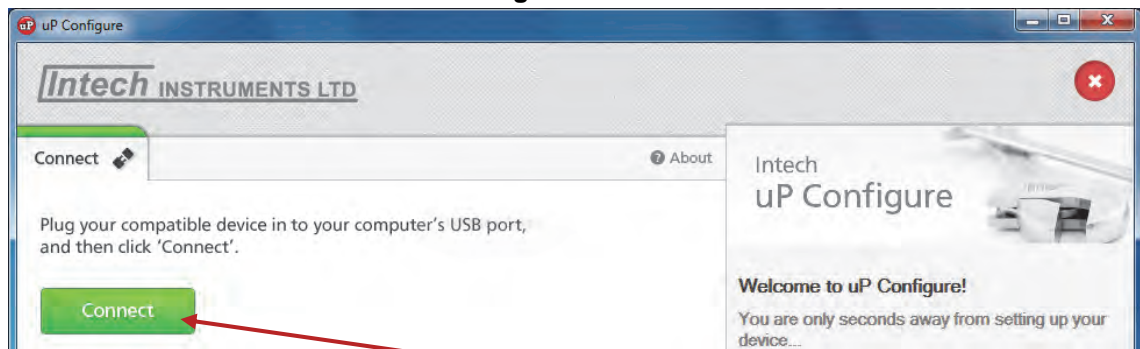

### Configuring the Z-2400-A20:

Starting with your Z-2400-A20 connected to your computer via the XU-USB programming key, Click on the Connect button. The next screen that comes up is the 'Overview' of the Z-2400-A2 node connected.

### uP Configure Overview Screen

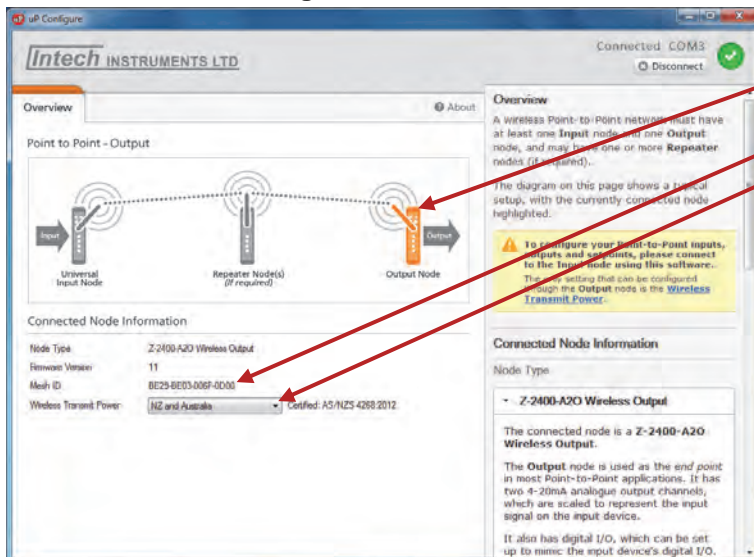

This screen shows:

- which node is connected by highlighting it in orange.
- The Mesh ID assigned to that unit.
- The Wireless Transmit Power setting.

### Wireless Transmit Power

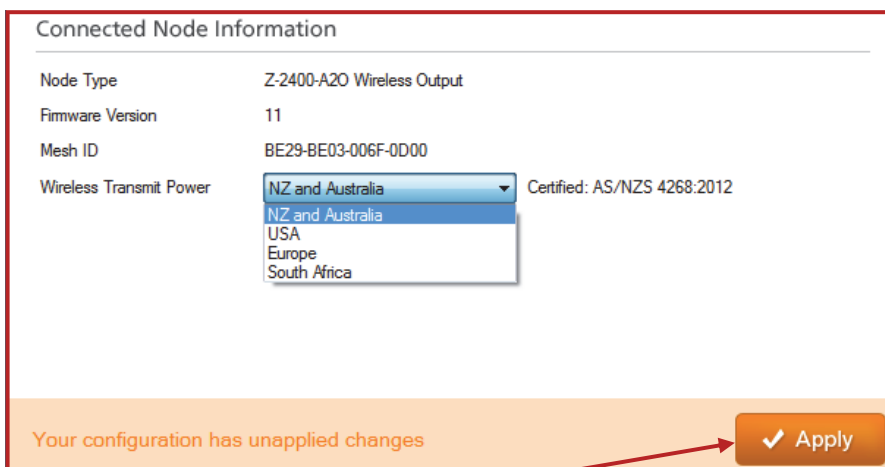

The only requirement to set up the Z-2400-A20 is the 'Wireless Transmit Power'. Click on the drop down menu as shown where you can select your region.

**This setting is important and must be set to comply with the wireless standards of your area.**

Remember to **ALWAYS** click the 'Apply' button after you change any settings, this will program the new settings to your Z-2400-A20 node.

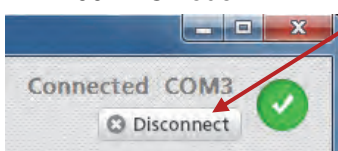

To disconnect the Z-2400-A20 node from your computer, click on Disconnect in the top right corner of the screen.

## Configuring the Z-2400-A2I:

The Z-2400-A2I Input node connects to your computer the same as the Z-2400-A2O Output node, via the XU-USB programming key. Click on the Connect button in the uP Configure software to get started.

The Overview page also has the same information: node type, Mesh ID and Transmit Power. You'll also notice a row of tabs across the top left hand side of the screen for setting up the inputs, outputs and setpoints.

### Z-2400-A2I Overview

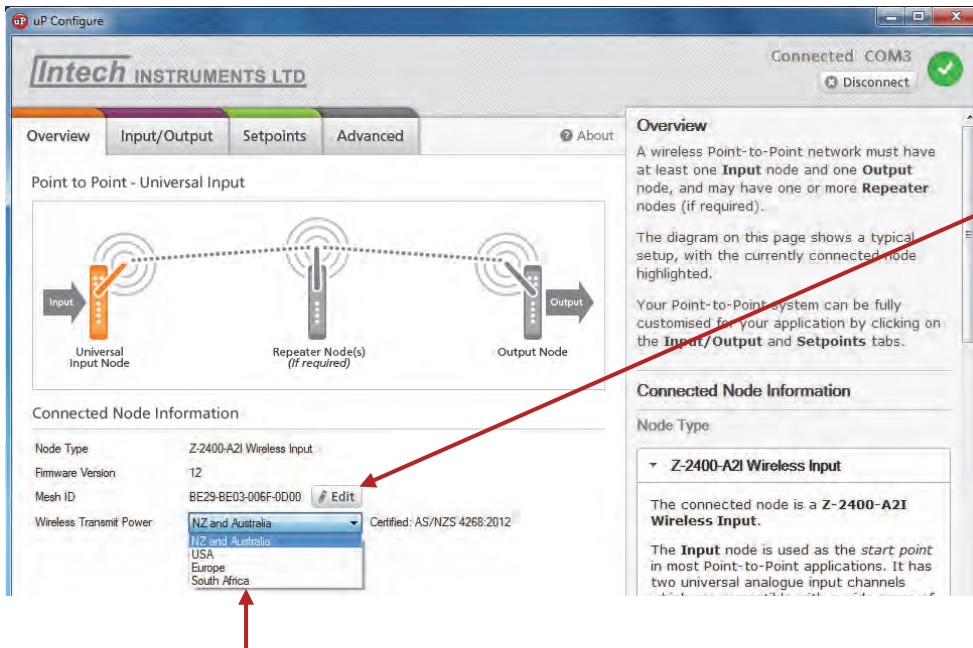

#### Mesh ID

If for any reason you have to replace the Input or Output node, you can change the Mesh ID of the Input node to match the Output node.

**Note:** The Z-2400-A2IO, Input and Output node kit, are supplied together with matching unique Mesh IDs.

#### Wireless Transmit Power:

The first parameter to configure is the 'Wireless Transmit Power'. Click on the drop down menu as shown and select your region. **This setting is important and must be set to comply with the wireless standards of your area.**

### Z-2400-A2I Analogue Input Configurations

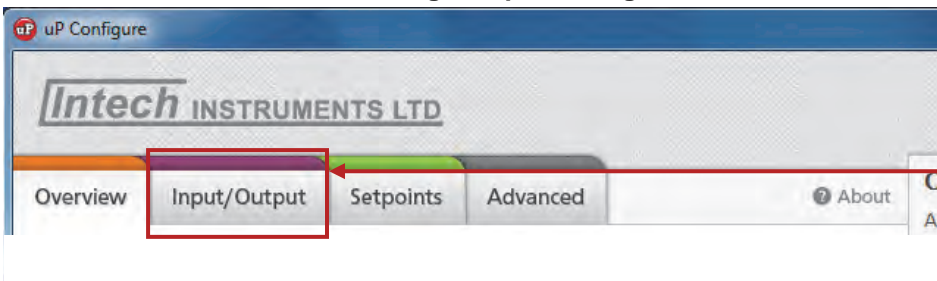

To configure the Analogue inputs, click on the 'Input/Output' tab at the top. Here you can go through each drop down menu and each value box to configure the inputs to your required input type.

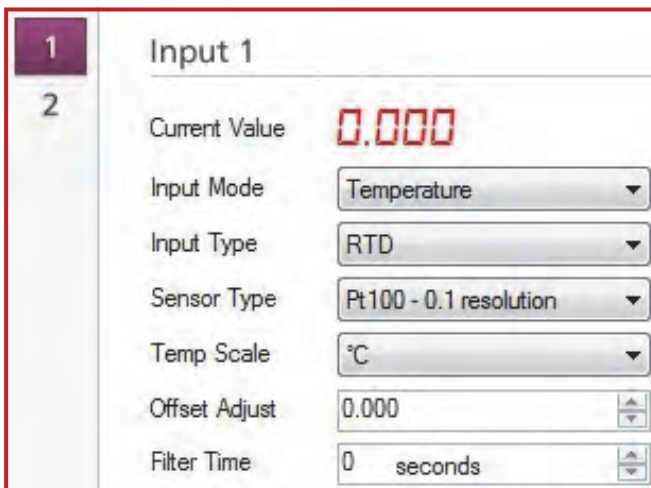

**Input Mode:** This drop down menu is where you select your input type such as Temperature, 4~20mA, Voltage etc. (Default = 4~20mA.)

**Input Type:** This is the sub menu of the Input Mode where you can set next level of input type, such as an RTD or thermocouple etc.

**Sensor Type:** This drop down menu is for inputs that have a specific sensor type, eg RTD with a Pt100 sensor, or thermocouple with a type K sensor.

**Temperature Scale:** The temperature scale is visible for temperature sensor types (RTDs/Thermocouples) and allows you to set for °C or °F.

**Input Range:** Input range is the sub menu for value related input types such as 4~20mA for mA type, or 0~10Vdc for Voltage type etc.

**Display Value:** The 'Display Value' is an area between transmission to give an incoming analogue signal meaning. For example: A 4~20mA input from a pressure sensor = a display value of 0~100(kPa).

Input Mode: mA

Input Range: 4-20mA

Offset Adjust: 0.000

Filter Time: 0 seconds

Linearization: OFF

[Manually Adjust Clamping](#)

Scaling/Offset

Mode: mA (4.000 to 20.000)

**Offset Adjust:** Offset adjust is for calibration purposes only, this allows you to fine tune the Display Value of an incoming signal.

**Filter Time:** The filter time can be used to help filter out any electrical noise on the input signals. This can be set in 1 second increments.

**Linearisation:** This brings up a table where you can set your own linearisation values manually. There are up to 32 user defined points for curve fitting.

**Manually Adjust Clamping:** By clicking on the 'Manually Adjust Clamping' link, you can manually configure the clamping to a range that suits your specific design. (Default values are factory set.)

**Scaling/Offset Mode:** Allows you to custom set the input value (eg 4~20mA) to a specific display value (eg -50~+50) using the edit tab. You can also select to calibrate with live input signals by selecting the 'Live 2-Point Calibration'.

Output (Retransmission)

Output Value: 4.000 mA

Display Value Of: 4.000  
= 4.000 mA Output

Display Value Of: 20.000  
= 20.000 mA Output

**Output Retransmission:** The Z-2400-A2O output node is only able to supply an isolated 4~20mA loop from it's analogue outputs. This is where you set the Input nodes 'display value' to be transmitted to a 4~20mA signal. e.g. An RTD Pt100 input with a range of 0~100°C will be set to: '0 = 4mA' and '100 = 20mA'.

⇒ Or if the Input is 4~20mA, then the 'Output Retransmission' should be set to: '4 = 4mA' and '20 = 20mA' as shown.

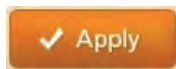

Remember to **ALWAYS** click the 'Apply' button after you change any settings, this will program the new settings to your Z-2400-A2I node.

### Z-2400-A2I Digital and Relay Setpoints

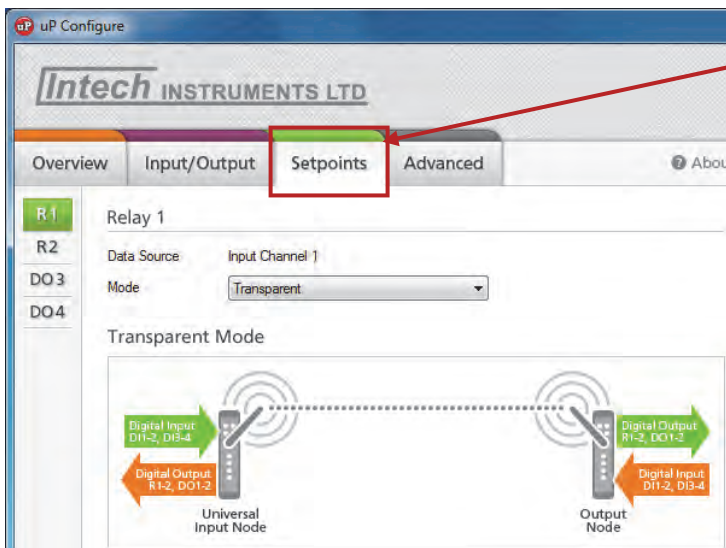

The next setup is the Setpoints tab, to configure the Relay and Digital outputs.

There are three main 'Mode' options for each output: Transparent, Control, and Alarm.

**Transparent:** This mode simply sends the digital input from either node to the output of the other. (Input state or pulse = output state or pulse.)

Transparent Signals Between Nodes From Z-2400-A2I to Z-2400-A2O and Z-2400-A2O to Z-2400-A2I		
Digital Input 1	→	Relay Output 1
Digital Input 2	→	Relay Output 2
Digital Input 3	→	Digital Output 3
Digital Input 4	→	Digital Output 4

(Default relay state is normally open.)

**Control:** In the control mode, the Output node's digital outputs mimic the digital outputs of the Input node. Up to four set points can be assigned to control an event based on the signals coming from the analogue input channels. For example:

*A situation where a sensor is in a separate location to a heat switch. Room temperature is measured by the Z-2400-A2I Input node's analogue input 1. The Input node closes it's own relay output 1, which indicates to the Z-2400-A2O Output node to close it's relay output 1. This switches the heat on in the separate location until the room heats to the correct temperature, where the Input node then releases it's relay output 1, signaling for the Output node to do the same.*

Control Signals From Z-2400-A2I to Z-2400-A2O		
Analogue Input	Controls Input Node	Mimicked to Output Node
Analogue Input 1	Relay 1	Relay 1
	Relay 2	Relay 2
Analogue Input 2	Digital Output 3	Digital Output 3
	Digital Output 4	Digital Output 4

**Alarm:** The alarm mode works in exactly the same way as the control mode, where the digital outputs are mimicked, the difference is how their respective functions are setup to work. Instead of an event action, as per the selections in the control mode, the alarm mode has configurable alarm setpoint values, with options for hysteresis and also the alarm delay timers set in seconds.



Remember to **ALWAYS** click the 'Apply' button after you change any settings, this will program the new settings to your Z-2400-A2I node.

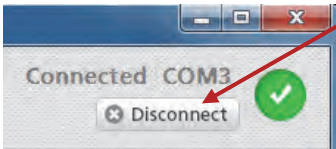

To disconnect the Z-2400-A2I node from your computer, click on Disconnect in the top right corner of the screen.

### Configuring the Z-2400-A2R:

With the Z-2400-A2R repeater node, there are only two parameters to configure: the 'Mesh ID' and the 'Wireless Transmit Power'. Because the repeater is sold separate to the Input & Output nodes, it requires the Mesh ID pairing with your Input/Output Z-2400-A2 wireless set.

#### Z-2400-A2R Overview

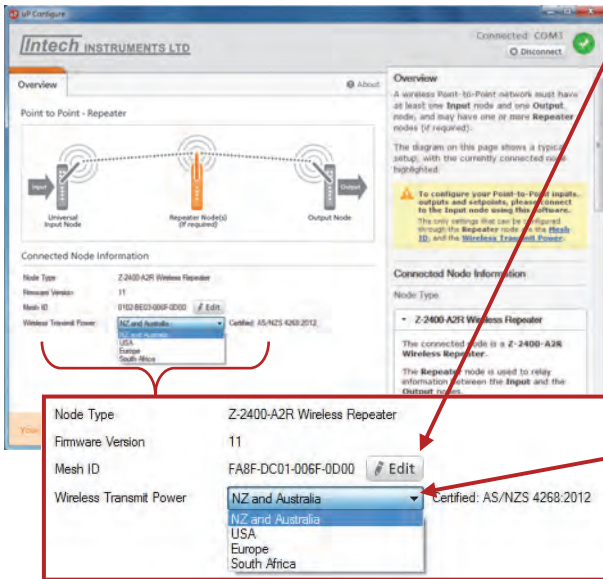

**Mesh ID:** This step will require you to copy the unique Mesh ID from your Z-2400-A2O Output node. This can be found by Connecting the Output node to the uP Configure software and copying the 16 digit Mesh ID number from the 'Overview' screen as shown on page 10.

After you have then properly connected the repeater node to your PC and have the 'Overview' screen up, click on the 'Edit' button next to the Mesh ID number, and then type in the Mesh ID number exactly as you have copied down from the Output node.

#### Wireless Transmit Power:

Next click on the drop down menu as shown and select your region. **This setting is important and must be set to comply with the wireless standards of your area.**

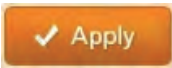

Remember to **ALWAYS** click the 'Apply' button after you change any settings, this will program the new settings to your Z-2400-A2R node.

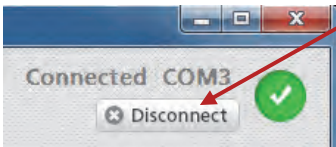

To disconnect the Z-2400-A2R node from your computer, click on Disconnect in the top right corner of the screen.

## Connecting up the Z-2400-A2 Series.

### Z-2400-A2 Series Power Supply Connection.

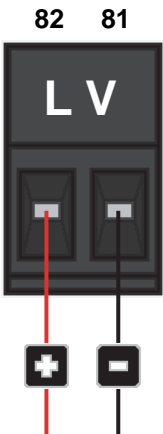

Power Supply: 9~36Vdc.  
Power Consumption: 2.5VA.

## Z-2400-A2I Analogue Input Connections.

**ALWAYS program the Z-2400-A2I before connecting inputs!**

**Remember to always reset (power off and on) the Z-2400-A2I after programming.**



**CAUTION**

**Risk of electric shock.** Dangerous and lethal voltages may be present on the terminal of the device. Please take appropriate precautions to ensure safety.



**CAUTION**

**Risk of Danger.** The sensor input can potentially float to dangerous and unexpected voltages depending on what external circuit it is connected to. Appropriate considerations must be given to the potential of the sensor input with respect to earth common.

### Sensor Break for Analogue inputs.

Upscale: RTD and Thermocouple inputs only.

Downscale: Broken wireless link and all other input types.

### Connecting RTDs to the Z-2400-A2I Analogue Inputs.

**Note 1.** To minimise lead resistance errors, 3 wire RTDs should be used. If 2 wire RTDs are used, small offset errors can be compensated for in the software.

**Note 2.** All RTD cable to be screened and the screens earthed at one end only. The three wires must be the same resistance. (i.e. the same type and size.) Refer to 'Z-2400-A2 Wiring and Installation' for recommended types.

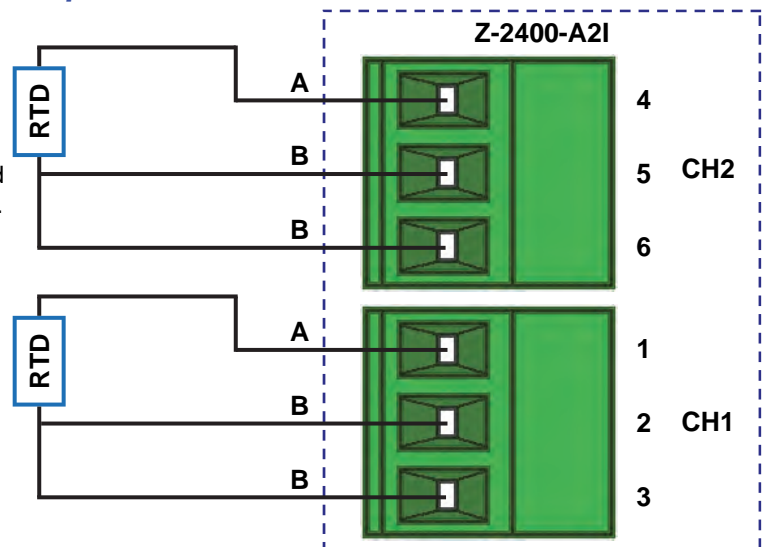

### Connecting Thermocouples to the Z-2400-A2I Analogue Inputs.

**Note 1.** When using the default integral CJC for accurate thermocouple measurement, especially low temperature:

- Avoid drafts and temperature differences across terminals (not to be exposed to direct sunlight).
- Once installation is complete, close the cabinet door and allow the cabinet to reach equilibrium. This may take several hours.
- Place all the thermocouple probes into a calibrated thermal bath at temperature of interest. Any errors can be zeroed out in software.

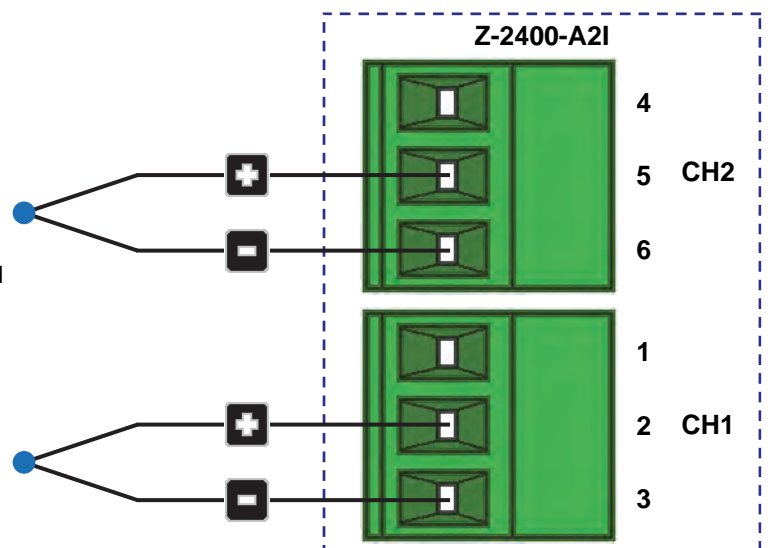

## Connecting Voltage Signals to the Z-2400-A2I Analogue Inputs.

**Note 1.** Input voltage must not exceed 24Vdc.

**Note 2.** All cables to be screened, and the screens earthed at one end only.

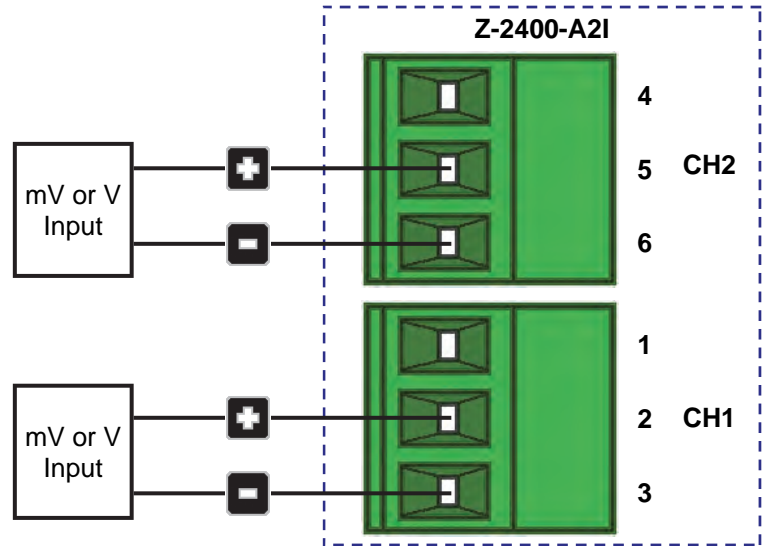

## Connecting Current Signals to the Z-2400-A2I Analogue Inputs.

**Note 1.** Input voltage must not exceed 24Vdc.

**Note 2.** The Z-2400-A2I must remain powered up to ensure the integrity of the mA loop. If the Z-2400-A2I is not powered, the 4~20mA loop is broken.

If a constant 4~20mA loop connection is required, it is recommended that you use a resistor across the Z-2400-A2I analogue input terminal, and re-program the Z-2400-A2I input for Voltage instead.

i.e. 250Ω for 1~5V input.  
500Ω for 2~10V input.

**Note 3.** Because the Z-2400-A2I inputs are totally isolated, it is safe to use the same instrument quality power supply on both channels as well as the power supply for the device.

**Note 4.** All cables to be screened and the screens earthed at one end only.

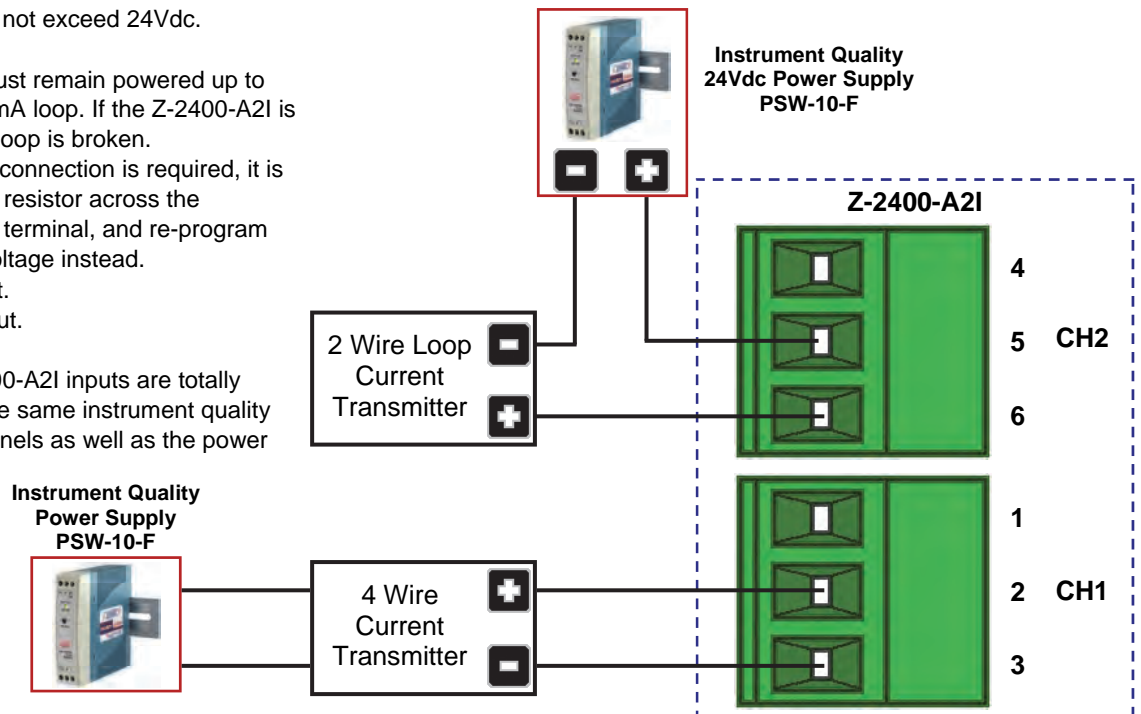

## Connecting Pulse, Frequency & On/Off State Signals to the Z-2400-A2I Analogue Inputs.

Both the two analogue inputs (CH1&2) plus the four dedicated digital inputs (DI 1~4) can be used for pulse and frequency outputs from flow or energy meters. These inputs can also be used for on/off state inputs.

**Note 1.** Inputs can be used as state Pseudo Digital inputs for sensing a clean, voltage free, field contact.

**Note 2.** All cables to be screened and the screens earthed at one end only.

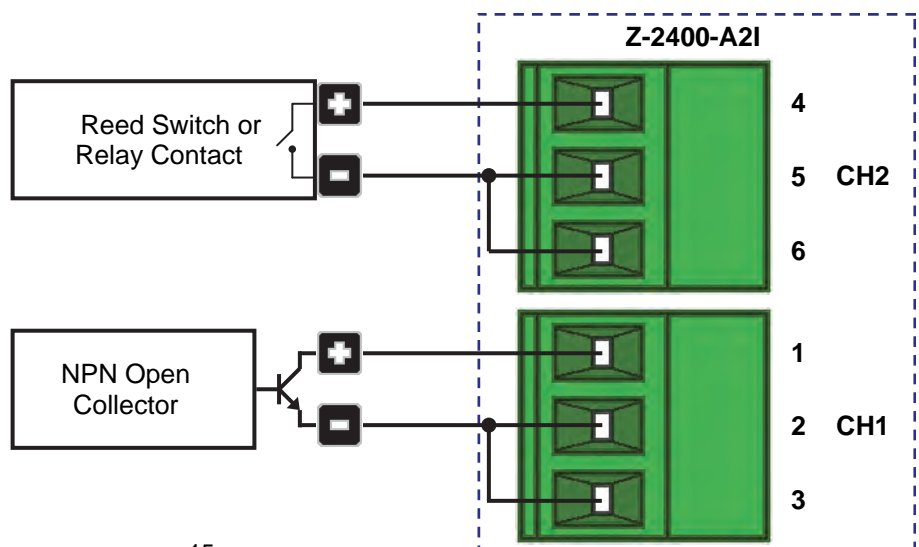

## Connecting Pulse, Frequency & On/Off State Signals to the Z-2400-A2I Analogue Inputs.

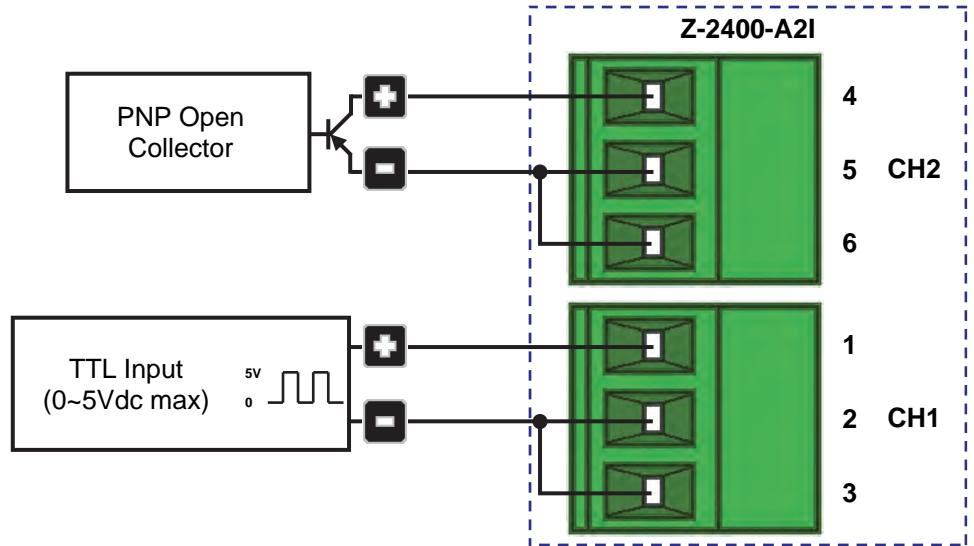

## Z-2400-A2I & Z-2400-A2O Digital Input/Output Connections.

The Digital Input/Outputs of the Z-2400-A2I & Z-2400-A2O can be transmitted both ways to allow for easy monitoring and control from either end of the wireless link, or a single direction if set to alarm/control mode.

### Transparent mode.

Digital signals between the Z-2400-A2I and Z-2400-A2O.		
Z-2400-A2I:	Signal Direction	Z-2400-A2O:
DI 1	▶	R 1
DI 2	▶	R 2
DI 3	▶	DO 3
DI 4	▶	DO 4
R 1	◀	DI 1
R 2	◀	DI 2
DO 3	◀	DI 3
DO 4	◀	DI 4

### Alarm or Control Mode.

Digital signals between the Z-2400-A2I and Z-2400-A2O.		
Z-2400-A2I:	Signal Direction	Z-2400-A2O:
RI 1	▶	R 1
RI 2	▶	R 2
DO 3	▶	DO 3
DO 4	▶	DO 4

## Connecting to the Z-2400-A2I & Z-2400-A2O Relay Outputs.

The two relay outputs can be used for contact switching.

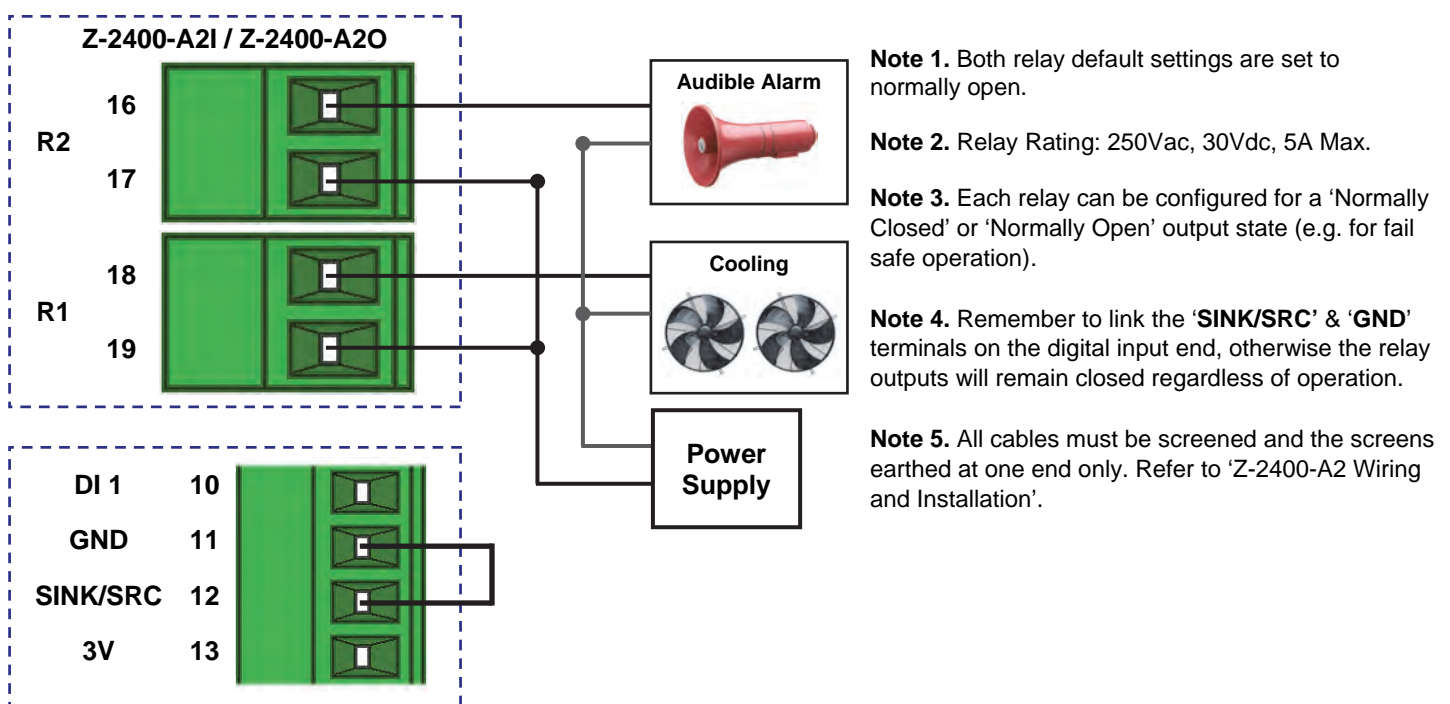



## Connecting to the Z-2400-A2I & Z-2400-A2O Digital Outputs.

The two digital outputs can be used for pulse and frequency into a counter or totaliser. 30Vdc, 1A max.

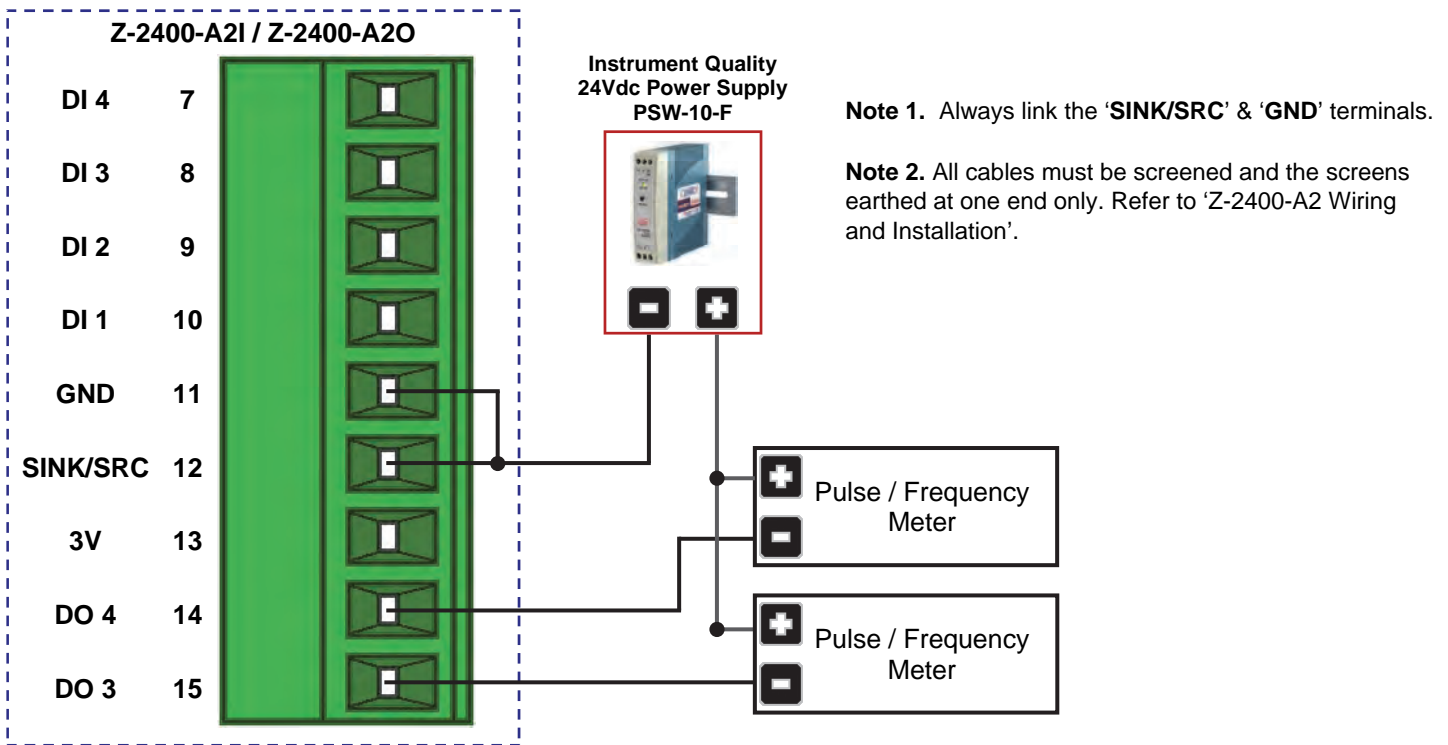

## Connecting Pulse, Frequency & On/Off State Signals to the Z-2400-A2I & Z-2400-A2O Digital Inputs.

The four digital inputs from either Z-2400-A2I & Z-2400-A2O can be used for pulse and frequency outputs from slower sensor types e.g., Rain Gauge and also for on/off state inputs.

**Warning:** The digital inputs are not isolated from the node power supply. Therefore, if you are using an external power supply on the digital inputs, it must be a separate isolated instrument quality power supply.

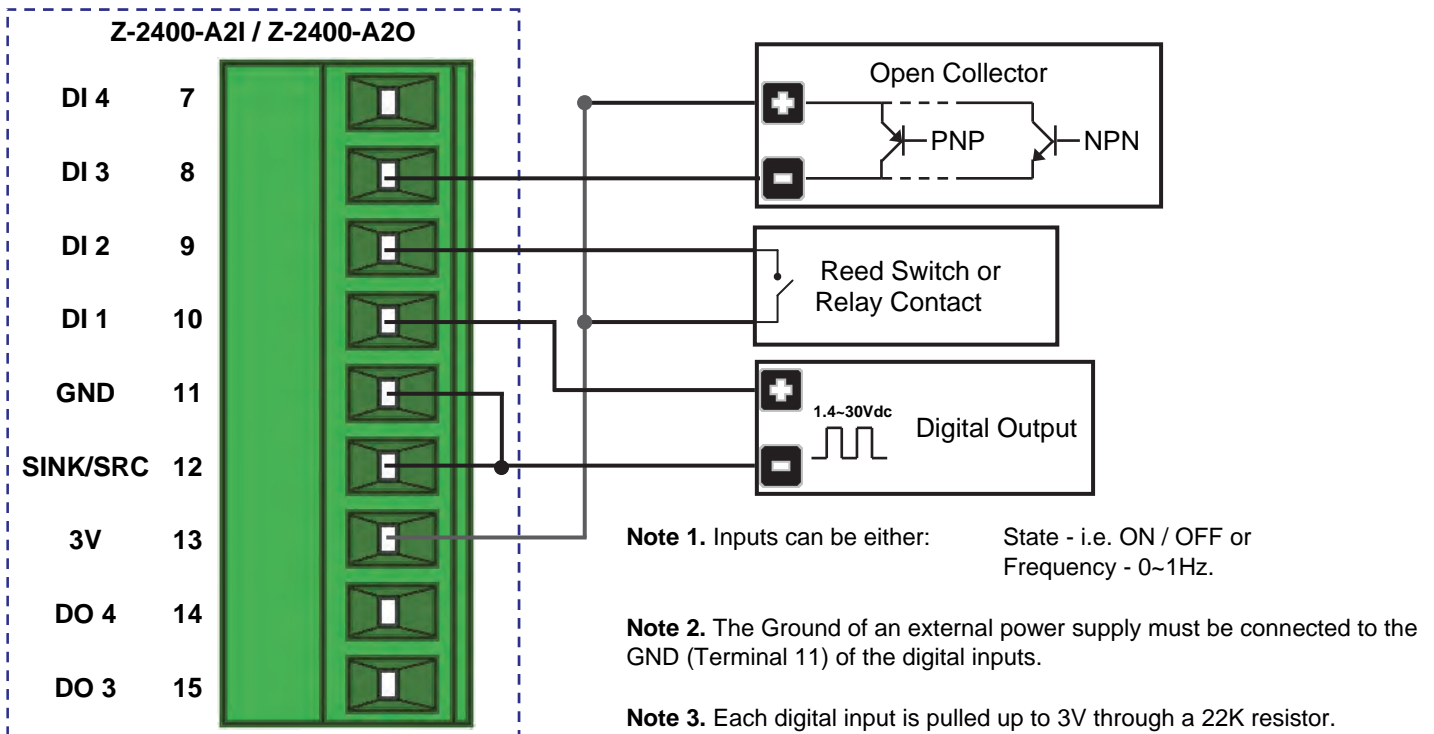

## Z-2400-A2O Current Loop Outputs.

Instrument Quality  
24Vdc Power Supply  
PSW-10-F



**Note 1.** Because the Z-2400-A2O outputs are totally isolated, it is safe to use the same instrument quality power supply on both channels as well as the power supply for the device.

**Note 2.** All cables to be screened and the screens earthed at one end only.

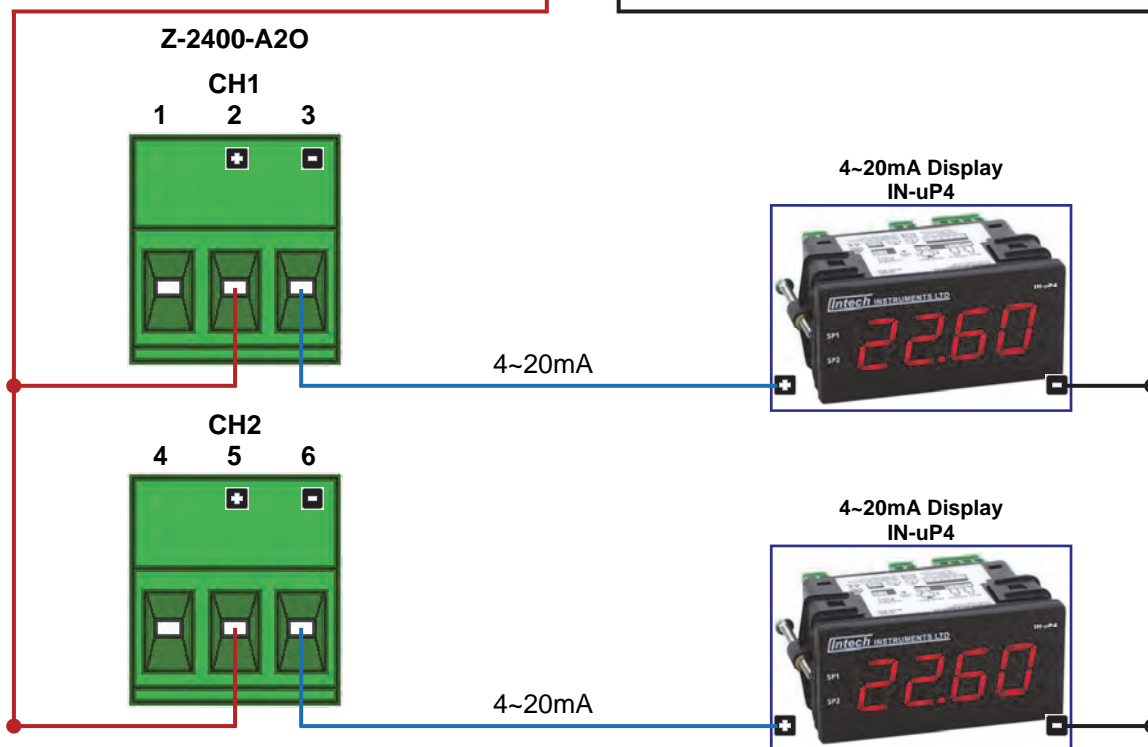

## Z-2400-A2 Series Wiring, Installation and Maintenance.

**THE Z-2400-A2 NODES ARE TO BE INSTALLED AND SERVICED BY SERVICE PERSONNEL ONLY. NO OPERATOR / USER SERVICEABLE PARTS.**

**BEFORE YOU BEGIN WIRING:** Ensure that all programming is carried out **BEFORE** any wiring takes place! All power and signals must be de-energised **BEFORE** connecting any wiring.

### Z-2400-A2 Wiring & Installation.

#### Mounting:

\* Also refer to Physical Layout (Page 6).

- 1) Mount so the terminals are in a clean environment.
- 2) Do not subject to vibration or excess temperature or humidity variations.
- 3) Avoid mounting in cabinets with power control equipment.
- 4) Allow 10mm minimum clearance between the Z-2400-A2 terminals and ANY conductive material.

#### Analogue Signal Wiring:

- 1) All signal cables should be good quality overall screened INSTRUMENTATION CABLE with the screen earthed at one end only.
- 2) Signal cables should be laid a minimum distance of 300mm from any power cables.
- 3) For 2 wire current loops, 2 wire voltage signals or 2 wire current signals, B5102ES is recommended. For 3 wire transmitters and RTDs B5103ES is recommended.
- 4) It is recommended that you do **not** ground analogue signals.
- 5) It is recommended to use power supplies with ungrounded outputs.
- 6) Lightning arrestors should be used when there is a danger from this source.
- 7) Refer to diagrams for connection information.

#### Thermocouple Extension Wire:

- 1) Use the correct thermocouple extension or compensation cable. i.e. Thermocouple type, insulation type, correct colour coding.
- 2) It is recommended to install extension or compensation cable in a grounded conduit by themselves, or use overall screened cable with the screen earthed at one end only. Never run electrical wires in the same conduit.
- 3) All wires that must be spliced should be soldered, or a proper thermocouple termination block used.
- 4) Lightning arrestors should be used when there is a danger from this source.

### Thermocouples:

1. Avoid locating the thermocouple where it will be in a direct flame.
2. Never insert a porcelain or refractory tube suddenly in a hot area. Pre-heat gradually while installing.
3. Locate it where the average temperature will be measured. It should be representative of the mass. If necessary use several thermocouples to obtain the average temperature.
4. Immerse the thermocouple far enough so that the measuring junction is entirely in the temperature to be measured: nine to ten times the diameter of the protection tube is recommended. Heat conducted away from the junction causes an error in reading.
5. If the thermocouple is mounted horizontally and the temperature is above the softening point of the tube, a support should be provided to prevent the tube sagging. Otherwise install the tube vertically.
6. Keep the junction head and cold junction in the approximation of the ambient temperature. Especially in the Noble Metal Class.

### RTDs:

1. Avoid locating the RTD where it will be in a direct flame.
2. Locate it where the average temperature will be measured. It should be representative of the mass.
3. Immerse the RTD far enough so that the measuring point is entirely in the temperature to be measured, i.e. nine to ten times the diameter of the protection tube is recommended. Heat that is conducted away from the measuring point causes an error in reading.

### Power Supply Wiring:

1. Use Only Instrument Quality Power Supplies.
2. A readily accessible disconnect device and a 1A, 250Vac overcurrent device must be in the power supply wiring.

## Z-2400-A2 Commissioning.

- 1) **WARNING: Ensure that all programming is carried out BEFORE any wiring takes place!**
- 2) Check that the Z-2400-A2I has been set to the correct input ranges and all functions such as Upscale/Downscale Drive etc. Observe polarity and the correct terminal connections for wiring correctly. Only use certified calibration equipment. For Thermocouple calibration place the Z-2400-A2I and calibration equipment directly next to each other, in still air, with no direct sunshine. Allow the CJC junctions to equalise in temperature before commencing calibration. Lower temperature ranges are affected more by the CJC Junction (allow more time to equalise).
- 3) Once the above conditions have been met, and the wiring checked, apply power to the Z-2400-A2 and the loops and/or sensors. Allow at least a 5 minute warm-up period.
- 4) **Thermocouple Inputs only:** Due to the limits of error in a standard Thermocouple probe, and standard extension wire and compensating wire, an error can occur. E.g. In a type K Thermocouple installation an error of 2.2°C or 0.75% FSO can occur (whichever is greater).  
The Z-2400-A2I has an integral CJC sensor, the enclosure must be assembled and installed where it avoids drafts and temperature differences across terminals. Once installation is complete, close the cabinet door and allow the cabinet to reach equilibrium. This may take several hours. Place all the Thermocouple probes into a calibrated thermal bath at the temperature of interest or use a calibration standard Thermocouple at the same immersion depth and temperature of interest and adjust the Zero until the two temperatures agree.
- 5) **Calibration Check:** Take a reading of the value being measured on the Z-2400-A2I input, and ensure that this agrees with the level being indicated by the Z-2400-A2O output. Adjust for any differences. It is recommended to measure both a high and low value and compare these readings with your calibration device.

## Z-2400-A2 Maintenance.

### DC Voltage and Current Inputs:

- 1) Check the Sensor or Transducer supplying the signal to the Z-2400-A2I for wear or damage and replace if defective.
- 2) Check the cables connected to the Sensor or Transducer.
- 3) Repeat (5) of commissioning. **Do it regularly - at least once per year.**

### Thermocouple Inputs:

- 1) Replace defective protection tubes - even if they look good they may not be air or gas tight.
- 2) Check extension and compensating cable circuits, especially cables entering the Thermocouple sensor head.
- 3) Do not use the same Chromel-Alumel (Type K) Thermocouple below 540°C if it was used above 860°C.
- 4) Repeat (5) of commissioning. **Do it regularly - at least once per year.**

### RTD Inputs:

- 1) Replace defective protection tubes - even if they look good they may not be air or gas tight.
- 2) Check cables entering the RTD sensor head.
- 3) Repeat (5) of commissioning. **Do it regularly - at least once per year.**

## Troubleshooting.

It is possible that the ZigBee® wireless nodes will fail to communicate if they are in too close a proximity to each other. If you are trying a lab test before you fully commission on site, as is recommended, then make sure the distance between the Z-2400 wireless nodes is at least one metre.

1. Check the Output wireless node is powered up and PWR LED is lit.
2. Check the Output node network status LEDs are toggling 1, 2 then 2, 1.
3. If you are using a wireless Repeater, check the node is powered up and PWR LED is lit.
4. Check the repeater node network status LEDs are toggling 1, 2 then 2, 1. If these LEDs flash 1 & 2 at the same time it means the Repeater cannot connect to the Mesh either because:
  - a) The Output node is not powered up.
  - b) The ZigBee signal strength is too weak to connect (also check the Signal Quality LEDs).
  - c) A wrong Mesh ID has been programmed into the node.
5. Check the input wireless node is powered up and PWR led is lit.
6. Check the Input node network status LEDs are toggling 1, 2 then 2, 1. If these LEDs flash 1 & 2 at the same time it means the Input node cannot connect to the Mesh either because:
  - a) The Base node is not powered up.
  - b) The ZigBee signal strength is too weak to connect.
  - c) A wrong dip switch has been set.
7. After the power supply of the Output and Input nodes have been switched on, the Input node may take up to 1 minute to re-establish a wireless connection.

If you are using the uP Configure software and an error message comes up: 'No devices were discovered'.

1. Close uP Configure completely, unplug the XU-USB from your PC's USB port, and turn the power supply off to the Z-2400-A2 node.
2. Connect up the Z-2400-A2 node again as per the instructions on page 9, re-run the uP Configure software from the icon on your desktop, and try to connect again.

## Considerations & Limitations for Z-2400 Network Systems.

The ZigBee® system does not offer 100% connectivity, even when all the precautions are taken into account no one can guarantee a good link, as there are many factors that cause problems. With the Z-2400-A2 Series, additional repeaters can be used in between the Input and Output wireless nodes (particularly good when transmitting through solid walls). Instead of, or in addition to the use of repeaters, higher gain antennas can be used to extend the wireless range further.

## Antenna Options for Z-2400-A2 Wireless Series.

MODEL	DESCRIPTION
<b>ZA-OD24-2</b>	2.4GHz 2dBi Whip Antenna (0.5m of low loss cable and bulkhead attachment included.) Can be used either outdoor or indoor.
<b>ZA-OD24-5</b>	2.4GHz 5.5dBi Rubber Duck Antenna. Designed for indoor use.
<b>ZA-OD24-8</b>	2.4GHz 8dBi Omni Directional Antenna. (Mounting brackets & 3m of low loss coax cable included.) Can be used either outdoor or indoor.
<b>ZA-MD24-12</b>	2.4GHz 12dBi Mini Directional Antenna. (Mounting brackets & 3m of low loss coax cable included.) Designed for outdoor use.
<b>ZA-PG24-19</b>	2.4GHz 19dBi Parabolic Grid Directional Antenna. (Mounting brackets & 3m of low loss coax cable included.) Designed for outdoor use.



For more information on wireless antenna options and distances, see the 'Z-2400-Turbo Series Extended' datasheet.

**Intech** INSTRUMENTS LTD

[www.intech.co.nz](http://www.intech.co.nz)

Christchurch Ph: +64 3 343 0646  
Auckland Ph: 09 827 1930  
Email: [sales@intech.co.nz](mailto:sales@intech.co.nz)