

PSW-2 Power Supply.

Precision 200mA
DC Output Switch
Mode Power Supply.

Features.

- Better than most comparable linear supplies.
- Output Adjustable from 5V to 30V.
- Output Current of 200mA.
- Low Noise.
- Precision Regulation.
- Isolated Output Floats Close to Earth Potential.
- Short Circuit Tolerant.
- High Accuracy 0.1%.
- Universal AC/DC Power Supply.
- Compact DIN Rail Mount Enclosure.
- Available Standard or Special Calibration.
- Low Cost.

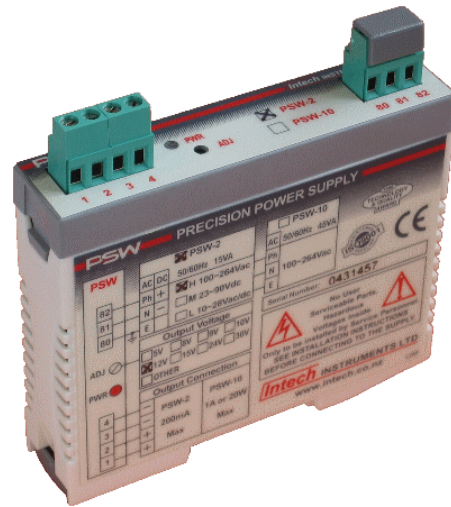

Description.

The PSW-2 is an isolated switch mode power supply that can supply a wide range of DC output voltages, from 5V to 30V, up to 200mA continuously, and operates over a wide range of input voltages.

Due to recent advancements in Switch Mode Power Supply technology, special techniques have been developed that make the PSW-2 both very low noise (typically less than 1mV) and high precision. Both line and load regulation is better than 0.1% over all conditions. (Within specified ranges.)

These attributes make the PSW-2 better than most comparable linear power supplies, while adding features such as DC input and voltage step-up capability. Eg 12Vdc input can be stepped up to 24Vdc output. (PSW-2-L version)

Ordering Information.

PSW-2-X Standard Unit: High Voltage Power Supply: 100~264Vac/dc. Output Voltage : 24Vdc.

PSW-2--
V PS

OUTPUT RANGES	
Output Voltages	V
5	5
8	8
9	9
10	10
12	12
15	15
24	24
30	30
Special Output Voltages	Z

INPUT POWER SUPPLY	PS ⁽¹⁾
High Voltage Power Supply: 100~264Vac/dc	H
Mid Voltage Power Supply: 23~90Vdc	M
Low Voltage Power Supply: 12~28Vac / 10~30Vdc	L

Note 1. The PSW-2-X is field selectable for 'H' or 'M' Power supply.

Note 2. Power supply 'H' is field selectable for 'M', and 'M' for 'H'. Power supply 'L' must be ordered separately.

Quality Assurance Programme.

The modern technology and strict procedures of the ISO9001 Quality Assurance Programme applied during design, development, production and final inspection grant long term reliability of the instrument. This instrument has been designed and built to comply with EMC and Safety Standards requirements.

PSW-2 Specifications.

Input Voltage Supply	-PSW-2-H	100~264Vac /dc.
	-PSW-2-M	23~90Vdc.
	-PSW-2-L	12~28Vac / 10~30Vdc.
Output Voltage		5~30Vdc.
Output Current	-PSW-2	200mA Max, unless specified otherwise. (See Below)
	-PSW-2-H	5 ~ 15Vdc Output: 300mA Max.
	-PSW-2-M	5 ~ 9Vdc Output: 300mA Max.
	-PSW-2-L	5 ~ 9Vdc Output: 300mA Max.
Output Ripple	-PSW-2-H	8mVrms / 25mVpp Max.
	-PSW-2-M	0.3mVrms / 10mVpp Max.
	-PSW-2-L, AC	50mVrms / 120mVpp Max.
	-PSW-2-L, DC	0.6mVrms / 20mVpp Max.
Load Regulation		<0.1%.
Line Regulation		<0.1%.
Short Circuit Tolerance	-PSW-2-H	Indefinite.
	-PSW-2-M	Indefinite.
	-PSW-2-L	1 minute.
Max Output Floats Above Earth		2.5Vrms.
EMC Emissions Compliance		EN 55022-A
EMC Immunity Compliance		EN 50082-1
Safety Compliance.		EN 60950
Mains Isolation		250Vac.
Isolation Test Voltage	-Mains to Output	3000Vac, 50Hz for 1 min.
	-Mains to Earth	1500Vac, 50Hz for 1 min.
Ambient Drift		<±0.01%/C FSO Typical.
R.F. Immunity		<1% Effect FSO Typical.
Operating Temperature		0~60C.
Storage Temperature		-20~80C.
Operating Humidity		5~85%RH Max. Non-Condensing.
Mounting		35mm Symetrical Mounting Rail.
Dimensions		L=100, W=22.5, H=100mm.
Weight		135g, Includes Packaging.

Product Liability. This information describes our products. It does not constitute guaranteed properties and is not intended to affirm the suitability of a product for a particular application. Due to ongoing research and development, designs, specifications, and documentation are subject to change without notification. Regrettably, omissions and exceptions cannot be completely ruled out. No liability will be accepted for errors, omissions or amendments to this specification. Technical data are always specified by their average values and are based on Standard Calibration Units at 25C, unless otherwise specified. Each product is subject to the 'Conditions of Sale'.

Warning: These products are not designed for use in, and should not be used for patient connected applications. In any critical installation an independant fail-safe back-up system must always be implemented.

Top Overview of PSW-2 Terminals.

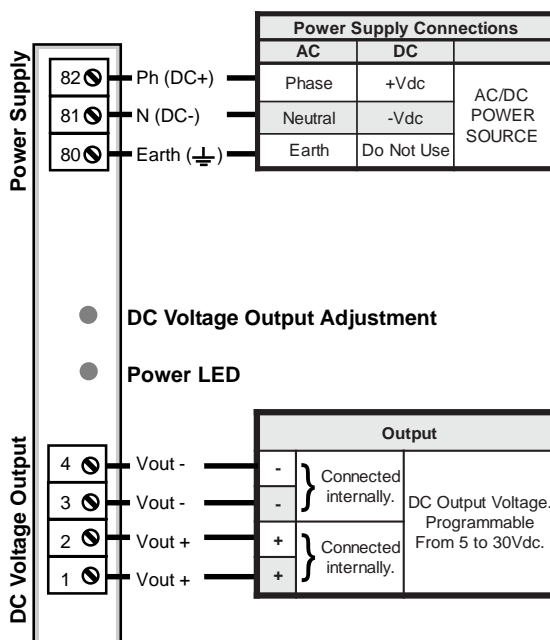

PSW-2 Enclosure Dimensions.

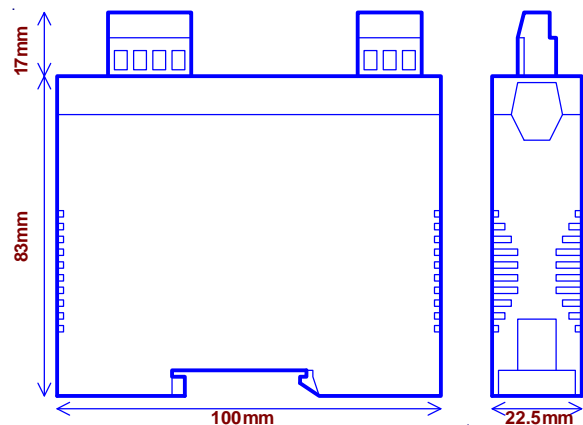

Section B. PSW-2 Calibration Information and Connection Examples.

THE PSW-2 IS TO BE INSTALLED AND SERVICED BY SERVICE PERSONNEL ONLY. NO OPERATOR / USER SERVICEABLE PARTS. All power and signals must be de-energised before connecting any wiring, or altering any Jumpers.

PSW-2 PCB Layout

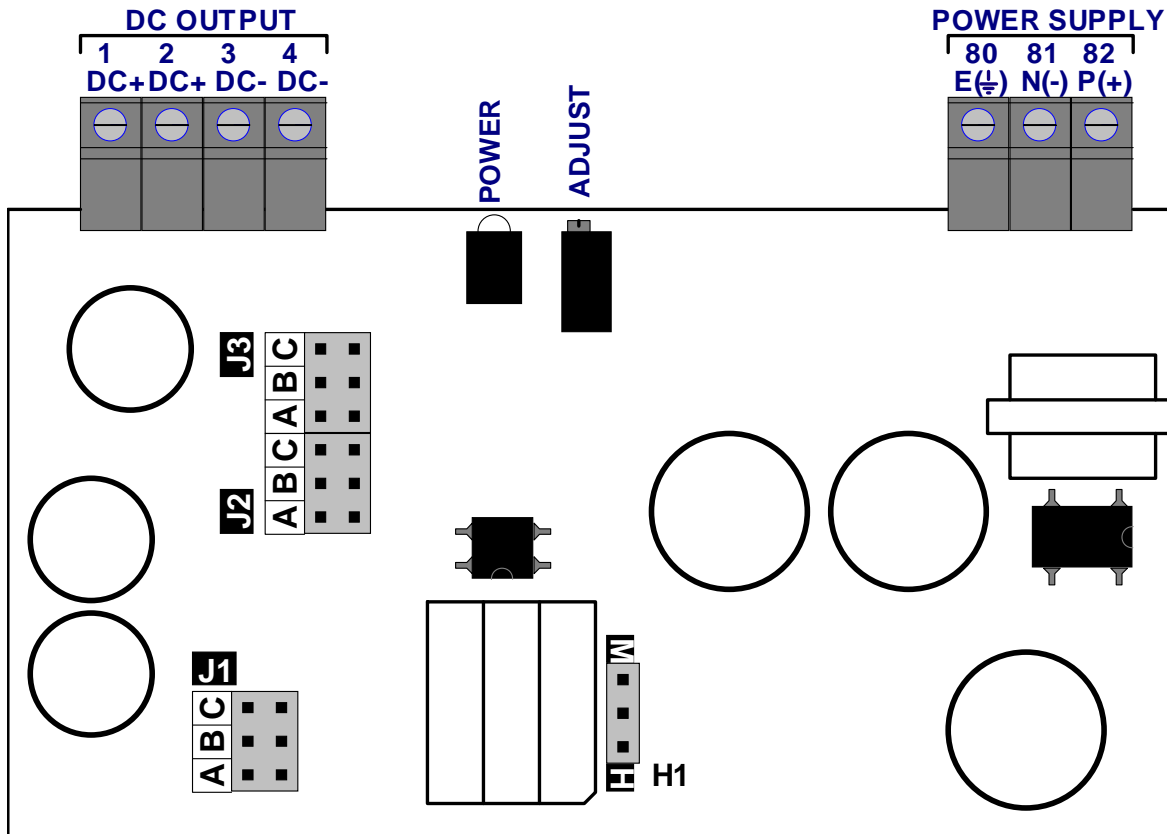

PSW-2 H1 Power Supply Jumper Settings.

WARNING: High Voltages Maybe Present. Only adjust jumper with power disconnected.

Power Supply Jumper Settings	
H1	Power Supply Voltage Range
H	Jumper for High: 100~264Vac/dc
M	Jumper for Mid: 23~90Vdc

Notes:

- 1/ Input Power Supply must be OFF before changing ANY Jumpers.
- 2/ Exceeding voltage ranges may damage the unit.
- 3/ Ensure the enclosure label is correctly labelled for the jumper position.
- 4/ Adjust H1 jumper with a pair of needle nose pliers.
- 5/ Low Voltage Power Supply version is fixed, and has no jumper. This must be ordered separately.

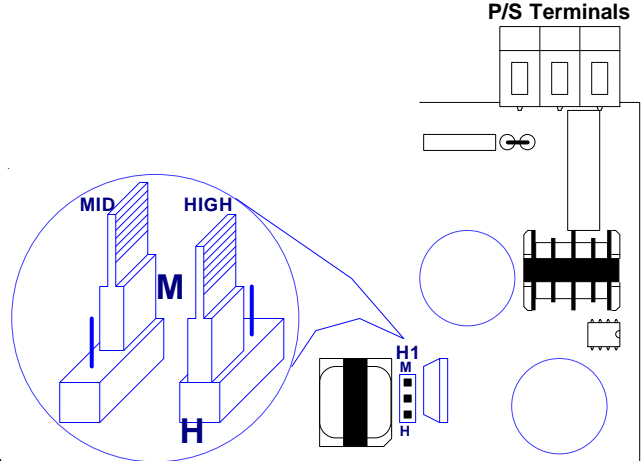

PSW-2 Output Voltage Selection.

Output Voltage Range Selection			
Output Voltage	J1	J2	J3
5~8Vdc	C	C	C
9~17Vdc	B	B	B
18~30Vdc	A	A	A

Notes:

- 1/ Input Power Supply must be OFF before changing ANY Jumpers.
- 2/ J1, J2 and J3 must have only 1 JUMPER each, and all three must be the same setting. I.e. Do not mix, 'A' 'B' or 'C'.
- 3/ Programming Example; for a 15Vdc output ALL jumpers must be in the 'B' location.
- 4/ Use the 'Adjust' pot to calibrate the output Voltage.

CAUTION: Dangerous Voltages may be present. The PSW-2 has no user serviceable parts. Protective enclosure only to be opened by qualified personnel. Remove ALL power sources before removing protective cover.

Wiring and Installation.
Single Unit.

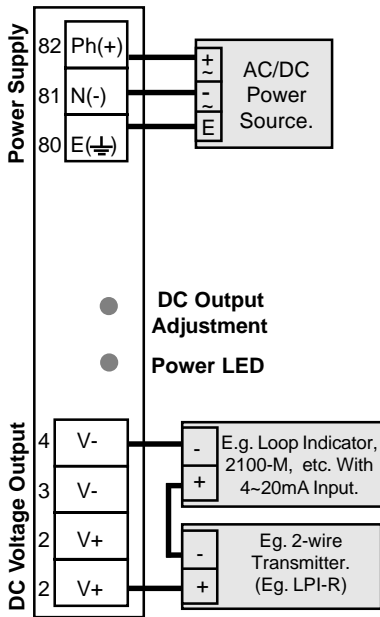

Dual Units - Common -Ve.

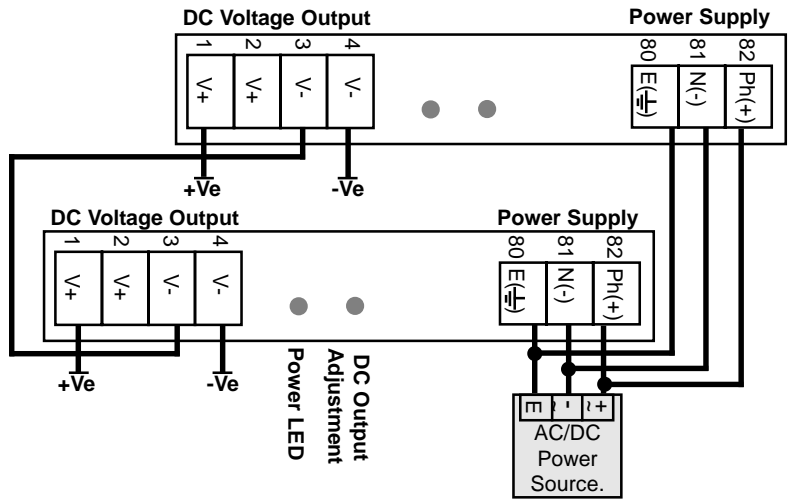

Dual Units - Split Rail.

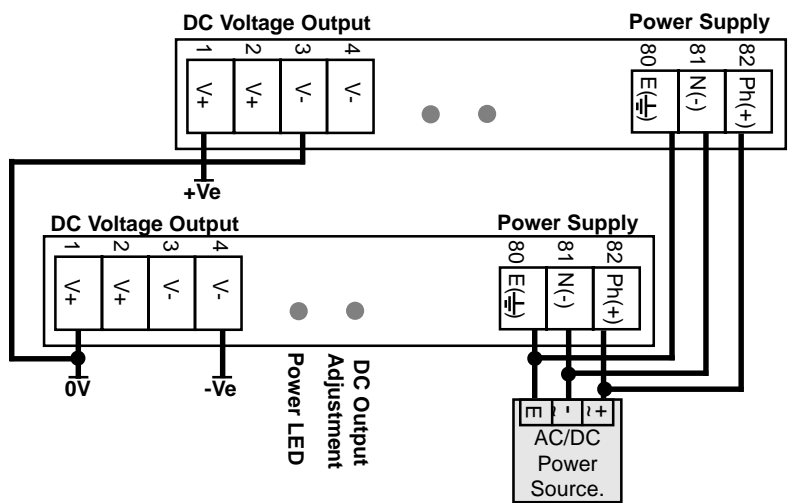

The Proper Installation & Wiring of the PSW-2.

All power and signals must be de-energised before connecting any wiring, or altering any Jumpers or Dip Switches.

Mounting.

- (1) Mount in a clean environment.
- (2) Draft holes must have minimum free air space of 20mm. Foreign matter must not enter or block draft holes.
- (3) Do not subject to vibration, excess temperature or humidity variations.
- (4) Avoid mounting near power control equipment.
- (5) Allow 10mm minimum clearance between the PSW-2 terminals and ANY conductive material.
- (6) To maintain compliance with the EMC Directives the PSW-2 is to be mounted in a fully enclosed steel fire cabinet. The cabinet must be properly earthed, with appropriate input / output entry points and cabling.

Cover Removal and Fitting.

To remove the PCB to access jumpers and dip switches, push in the GREY BUTTONS at both ends of the enclosure TOP, and slide the PCB from the BASE of the enclosure. To reassemble slide the PCB back into the BASE until both GREY BUTTONS 'snap' into place. Ensure the TOP of the enclosure is flush with the BASE on all sides.

Power Supply Wiring.

- (1) A readily accessible disconnect device and a 1A, 250Vac overcurrent device, must be in the power supply wiring.
- (2) For power supply, connect Phase (or +Ve) to terminal 82, Neutral (or -Ve) to 81, and Earth to 80. To ensure compliance to CE Safety requirements, the grey terminal insulator must be fitted to ALL mains terminals after wiring is completed. (i.e. terminals 82, 81 and 80.) For Non Hazardous Voltage power supplies (not exceeding 42.4V/peak or 60Vdc) terminals 81 and 80 may be linked together, instead of connecting an earth.

Intech INSTRUMENTS LTD
www.intech.co.nz
 Christchurch Ph: +64 3 343 0646
 Auckland Ph: 09 827 1930
 Email: sales@intech.co.nz