

PROFESSIONAL WEATHER STATION

Operation Manual

Table of Contents

1. Introduction.....	3
2. Warnings and Cautions.....	3
3. Quick Start Guide.....	3
4. Pre-Installation Checkout and Site Survey.....	3
4.1 Pre Installation Checkout.....	3
4.2 Site Survey.....	4
5. Setting Started.....	4
5.1 Contents.....	4
5.2 Sensor Set Up.....	5
5.2.1 Install wind vane.....	5
5.2.2 Install wind speed.....	6
5.2.3 Install Batteries.....	6
5.2.4 Mount outdoor sensor.....	7
5.2.5 Reset Button and Transmitter LED.....	7
5.3 Best Practices for Wireless Communication.....	8
5.4 Display console.....	9
6. Display Console Operation.....	10
6.1 Screen Display.....	10
6.2 Initial Display Console Set Up.....	10
6.3 Key function.....	11
6.4 Setting mode.....	12
6.4.1 BEEP.....	12
6.4.2 MAX/MIN Daily.....	12
6.4.3 DST(daylight saving time).....	12
6.4.4 Time zone.....	13
6.4.5 Time / Date.....	13
6.4.6 Pressure.....	13
6.4.7 Light.....	13
6.4.8 Temperature.....	14
6.4.9 Wind speed.....	14
6.4.10 Rain.....	14
6.4.11 Moon phase.....	15
6.5 Alarm mode.....	15
6.5.1 Display of Alarm value.....	15

6.5.2 Alarm mode setting.....	15
6.5.3 Alarm Setting Order.....	16
6.6 Max/min mode.....	16
6.7 Calibration mode.....	17
6.7.1 Calibration Order.....	17
6.8 Other Features.....	17
6.8.1 Factory Reset/Clear Memory.....	17
6.8.2 Backlight.....	17
6.8.3 Tendency indicators.....	18
6.8.4 Wireless Signal Strength Indicator.....	18
6.8.5 Weather forecast.....	18
6.8.6 Snooze.....	18
7. WIFI connection setting on mobile.....	19
7.1 Weather server.....	19
7.2 Connecting the Weather Station Console to WiFi.....	20
7.3 Registering with WeatherUnderground.com, WeatherBug.com and WeatherCloud.net.....	24
8. Glossary of Terms.....	27
9. Specification.....	30
10. Power Consumption.....	31
11. Maintenance.....	31
12. Troubleshooting Guide.....	31

1. Introduction

Thank you for your purchase of the Solar Powered Wireless WiFi Weather Station. The following user guide provides step by step instructions for installation, operation and troubleshooting.

2. Warnings and Cautions

 **Warning:** Any metal object may attract a lightning strike, including your weather station mounting pole. Never install the weather station in a storm.

 **Warning:** Installing your weather station in a high location may result in injury or death. Perform as much of the initial check out and operation on the ground and inside a building or home. Only install the weather station on a clear, dry day.

3. Quick Start Guide

Although the manual is comprehensive, much of the information contained may be intuitive. In addition, the manual does not flow properly because the sections are organized by components.

The following Quick Start Guide provides only the necessary steps to install, operate the weather station, and upload to the internet, along with references to the pertinent sections.

Required		
Step	Description	Section
1	Assemble and power up the Y shape sensor	5.2
2	Power up the display console and synchronize with Y shape sensor	5.3 - 5.4
3	Set date and time on console	6.4.5
4	Calibrate the relative pressure to sea-level conditions (local airport) on console	6.7
5	Reset the rain to zero on console	6.4.10
Optional		
6	Configure WiFi	7
7	Register and upload to Weather Server	7

4. Pre-Installation Checkout and Site Survey

4.1 Pre Installation Checkout

Before installing your weather station in the permanent location, we recommend operating the weather station for one week in a temporary location with easy access. This will allow you to check out all of the functions, insure proper operation, and familiarize you with the weather station and calibration procedures. This will also allow you to test the wireless range of the weather station.

4.2 Site Survey

Perform a site survey before installing the weather station. Consider the following:

1. You must clean the rain gauge every few months and change the rechargeable batteries every 2-3 years. Provide easy access to the weather station.
2. Avoid radiant heat transfer from buildings and structures. In general, install the sensor array at least 5' from any building, structure, ground, or roof top.
3. Avoid wind and rain obstructions. The rule of thumb is to install the sensor array at least four times the distance of the height of the tallest obstruction. For example, if the building is 20' tall, and the mounting pole is 6' tall, install $4 \times (20 - 6) = 56'$ away.
4. Wireless Range. The radio communication between receiver and transmitter in an open field can reach a distance of up to 330 feet, providing there are no interfering obstacles such as buildings, trees, vehicles, high voltage lines. Wireless signals will not penetrate metal buildings. Under most conditions, the maximum wireless range is 100'.
5. Radio interference such as PCs, radios or TV sets can, in the worst case, entirely cut off radio communication. Please take this into consideration when choosing console or mounting locations. Make sure your display console is at least five feet away from any electronic device to avoid interference.

5. Setting Started

5.1 Contents

QTY	Item
1	Receiver
1	Thermo-hygrometer-barometer transmitter
1	Y shape outdoor sensor(including 1xThermo-hygrometer / 1xRain Gauge / 1xTransmitter / 1x pole mounting clamp / 2xU-bolt / 4x screws , assembled)
1	Wind Vane
1	Wind speed sensor
1	Rain hopper
1	5V DC Adaptor
1	User manual

5.2 Sensor Set Up

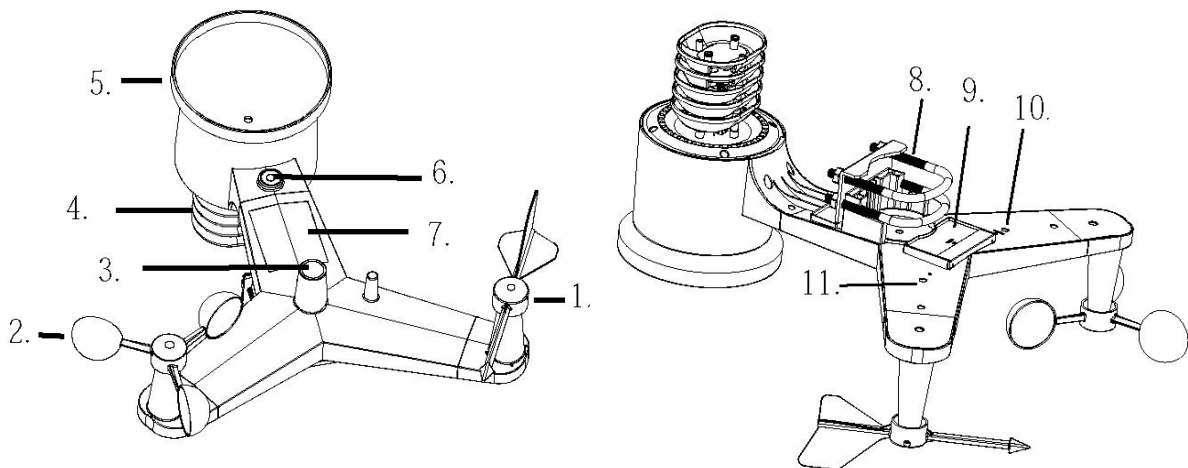

1. Wind Vane
2. Wind Speed Sensor
3. UV sensor/ Light sensor
4. Thermo-hygro sensor
5. Rain collector
6. Bubble level
7. Solar panel
8. U-Bolt
9. Battery compartment
10. Reset button
11. LED Indicator: light on for 4s if the unit power up. Then the LED will flash once every 16 seconds (the sensor transmission update period).

5.2.1 Install wind vane

Push the wind vane into the shaft. as shown in figure 1.

Tighten the set screw with as shown in figure 2. Make sure the wind vane spin freely.

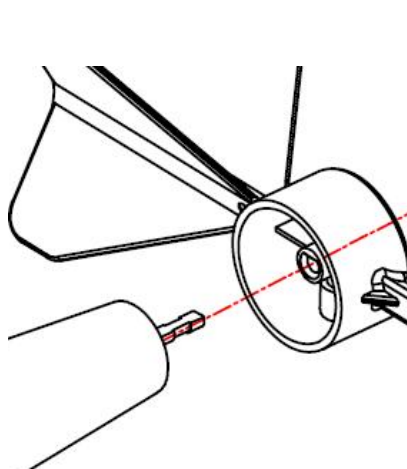

Figure 1

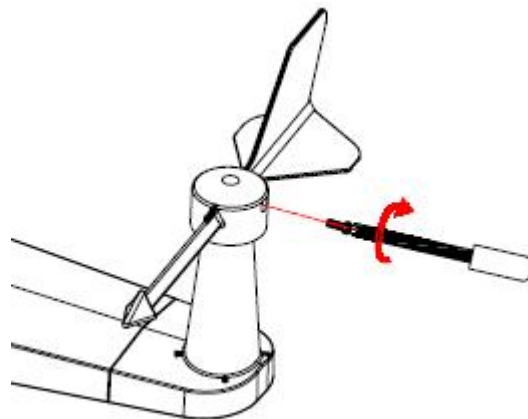

Figure 2

There are four alphabet letter of “N”, “E”, “S” and “W” around the wind direction, representing for the direction of North, East, South and West. Wind direction sensor has to be adjusted so that the directions on the sensor are matching with your real location. Permanent wind direction error will be introduced when the wind direction sensor is not positioned correctly during installation.

5.2.2 Install wind speed

Push the wind speed into the shaft. as shown in figure 4.

Tighten the set screw with as shown in figure 5. Make sure the wind speed spin freely.

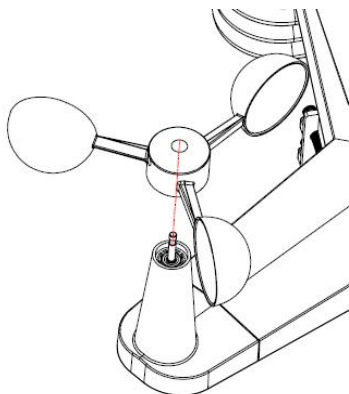

Figure 4

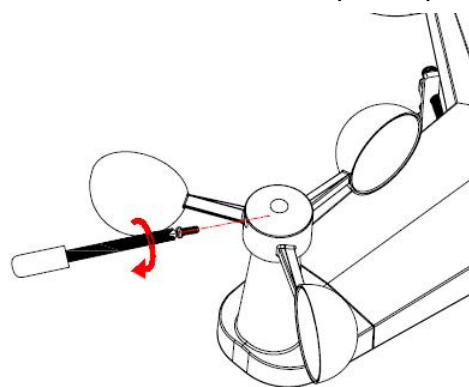

Figure 5

5.2.3 Install Batteries

Insert 3XAA rechargeable batteries in the battery compartment. The LED indicator on the back of the transmitter will turn on for four seconds and normally flash once every 16 seconds (the sensor transmission update period).

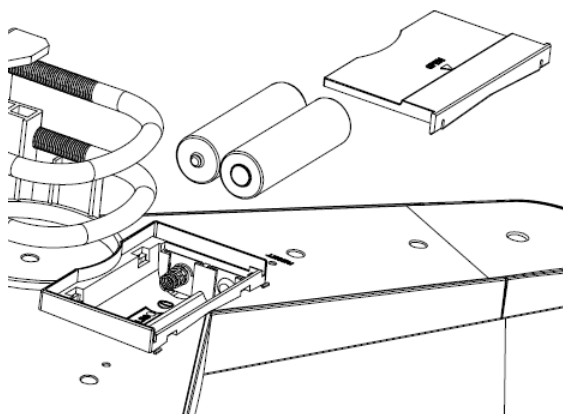

Figure 6

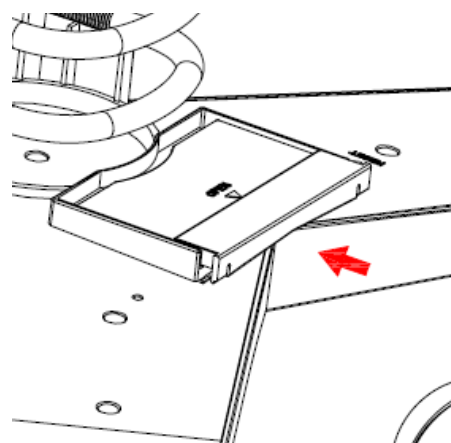

Figure 7

Note: If no LED light up or is lighted permanently, make sure the battery is inserted the correct way or a proper reset is happened. Do not install the batteries backwards. You can permanently damage the thermo-hygrometer.

5.2.4 Mount outdoor sensor

Mounting outdoor sensor to your mounting pole (purchased separately) with the U-bolts as shown in Figure 6.

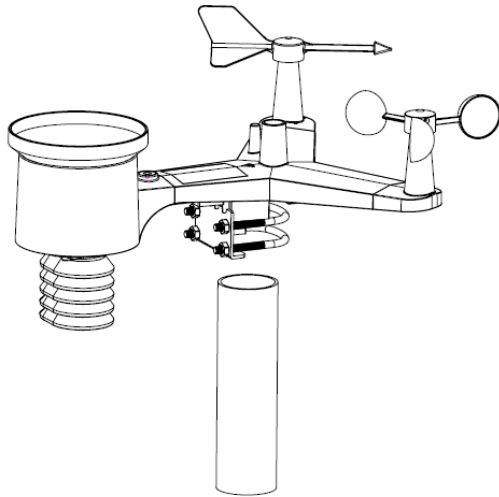

Figure 8

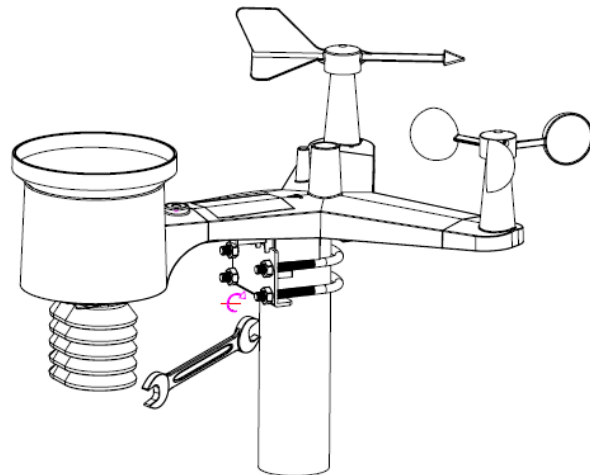

Figure 9

Use the bubble level beside the rain sensor as a guide to verify that sensors are level.

5.2.5 Reset Button and Transmitter LED

In the event the sensor array is not transmitting, reset the sensor array.

With an open ended paperclip, press and hold the **RESET BUTTON** for three seconds to completely discharge the voltage.

Take out the batteries and wait one minute, while covering the solar panel to drain the voltage.

Put batteries back in and resynchronize with console by powering down and up the console with the sensor array about 10 feet away.

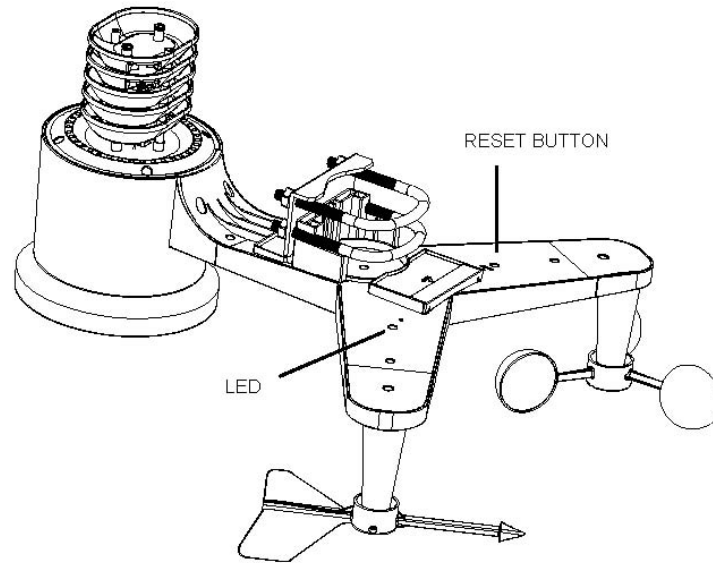

5.3 Best Practices for Wireless Communication

 **Note:** To insure proper communication, mount the remote sensor(s) upright on a vertical surface, such as a wall. **Do not lay the sensor flat.**

Wireless communication is susceptible to interference, distance, walls and metal barriers. We recommend the following best practices for trouble free wireless communication.

1. **Electro-Magnetic Interference (EMI).** Keep the console several feet away from computer monitors and TVs.
2. **Radio Frequency Interference (RFI).** If you have other 433 MHz devices and communication is intermittent, try turning off these other devices for troubleshooting purposes. You may need to relocate the transmitters or receivers to avoid intermittent communication.
3. **Line of Sight Rating.** This device is rated at 300 feet line of sight (no interference, barriers or walls) but typically you will get 100 feet maximum under most real-world installations, which include passing through barriers or walls.
4. **Metal Barriers.** Radio frequency will not pass through metal barriers such as aluminum siding. If you have metal siding, align the remote and console through a window to get a clear line of sight.

The following is a table of reception loss vs. the transmission medium. Each “wall” or obstruction decreases the transmission range by the factor shown below.

Medium	RF Signal Strength Reduction
Glass (untreated)	5-15%
Plastics	10-15%
Wood	10-40%

Brick	10-40%
Concrete	40-80%
Metal	90-100%

5.4 Display console

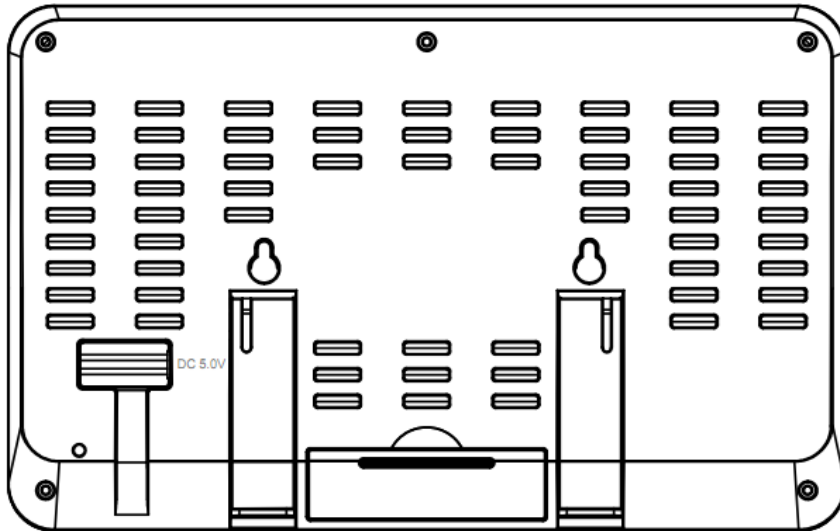

1. Insert the 5V AC adaptor into the back of the display console

Note: Place the outdoor sensor array about 5 to 10 feet from the display console and wait several minutes for the remote sensors to synchronize with the display console.

2. Insert 3 AAA batteries into the display console (optional).
3. Keep both sensor and the display console together for 15 minutes to lock in the sensor signals.
4. (Optional)-Spin the wind cups to simulate wind speed. Take the sensor to the sink and slowly drip water into the rain bucket to simulate rain.
5. After 15 minutes, follow the mounting instructions for proper placement of sensors.

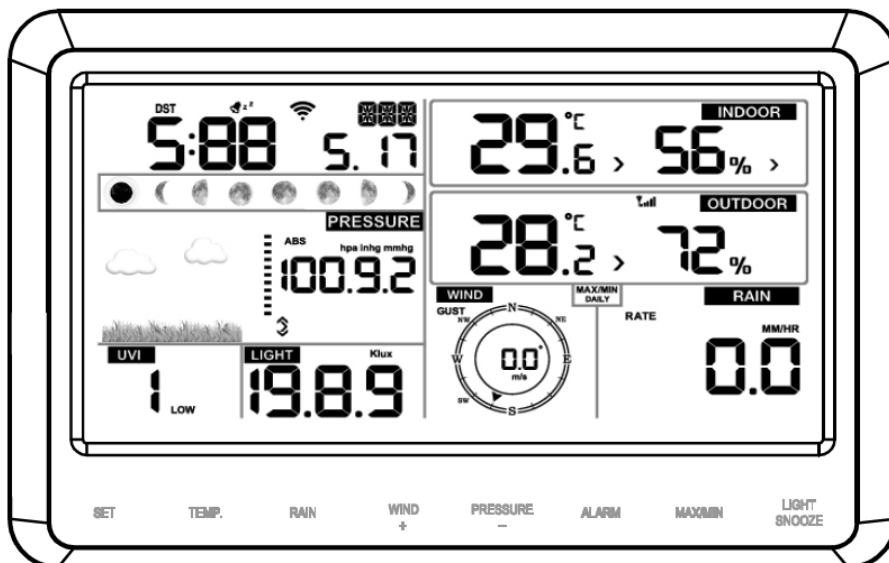

Note: Your display console should have readings in all sections. Wind and Rain will show 0's (connected) until wind or rian occur or are simulated.

Note: If you only use battery to power up display console, you must press LIGHT/SNOOZE key to light up the LCD before press any other key.

6. Display Console Operation

6.1 Screen Display

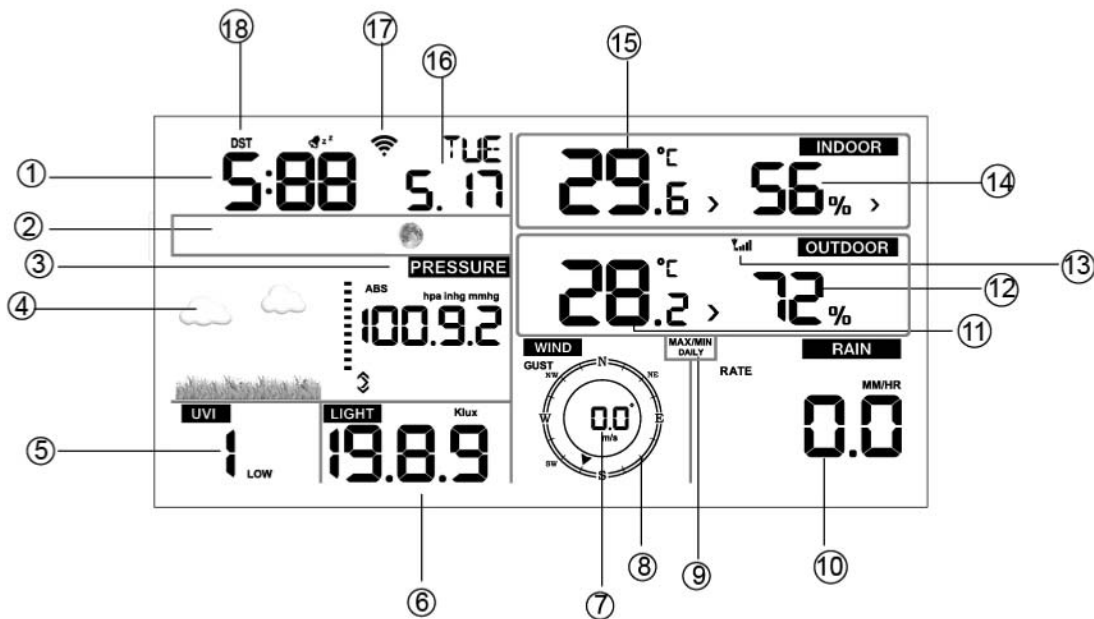

1. Time	10. Rain fall
2. Moon phase	11. Outdoor temperature
3. Barometric Pressure	12. Outdoor humidity
4. Weather forecast	13. RF icon
5. UV index	14. Indoor humidity
6. Light	15. Indoor temperature
7. Wind speed	16. Date
8. Wind direction	17. WIFI icon
9. MAX/MIN Daily	18. DST

6.2 Initial Display Console Set Up

Connect the power adapter to power up the display console.

The unit will show software version number 2 seconds after power reset.



The unit will turn on all segments of the LCD for 3 seconds after power reset, the unit will start to register the outdoor channel for 3 minutes.

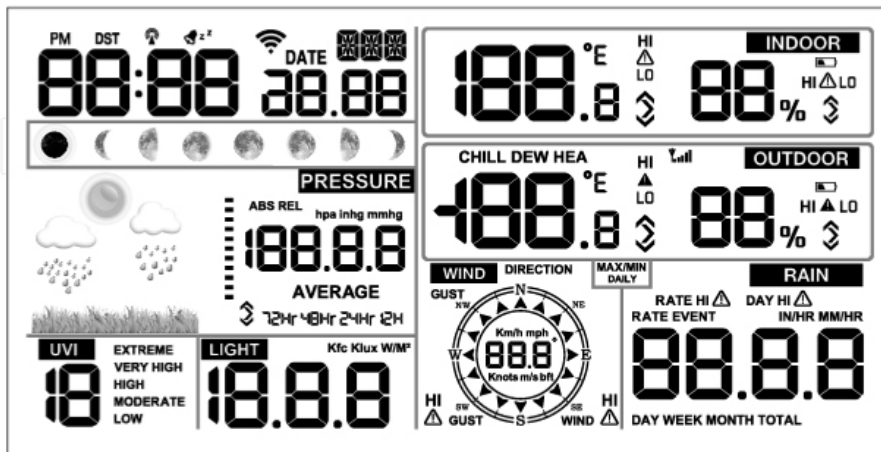

6.3 Key function

The console has eight keys for easy operation

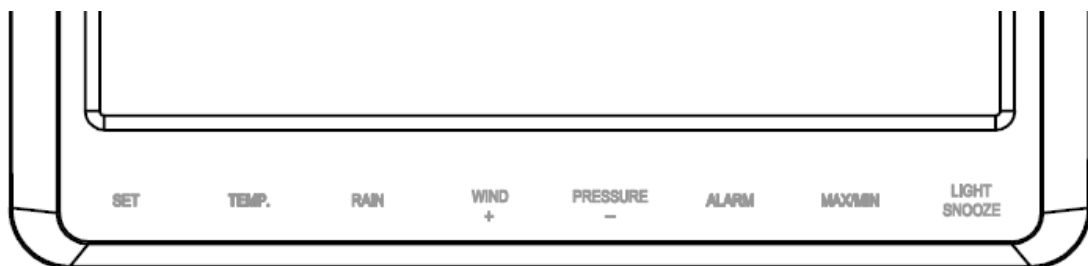

Key	Description
SET	Hold this key to enter setting mode
TEMP.	Press this key to view wind Chill, Heat Index, Dew Point Temperature Press the TEMP key 5s, will register new transmitter.
RAIN	Press this key to view Rain Rate, event, Rain Day, Rain Week, Rain Month, and Rain total Press the RAIN key 2s to reset current display rain
WIND +	Press this key to view wind/gust and wind direction
PRESSURE	Press this key to view Absolute Pressure average of 12hr, 24hr, 48hr and 72hr Press and hold 2s this key to view the absolute and relative pressure
ALARM	Press this key to view the alarm value of Temperature / Humidity/rain rate/rain day/wind
MAX/MIN	Press this key to view the MAX/MIN value of Temperature / Humidity/rain rate/rain day/wind/UVI/LIGHT/Absolute Pressure

LIGHT /SNOOZE

Press this key to adjust LCD backlight brightness: HI/MID/OFF

Note:

- 1) When power on, press **SET** key to reset the weather station and clear all records memory, and clears all user settings to default.
- 2) When power on, press **TEMP.** key to skip receive RF signal.
- 3) In Setting mode,pressing **WIND/+** or **PRESSURE/-** key select the unit or scrolls the value;keeping press and holding **WIND/+** or **PRESSURE/-** key for 2 second will increase/decrease digits in great steps.
- 4) The setting procedure can be exited at any time by either pressing the **LIGHT /SNOOZE** key or waiting for the 30-second time-out to take effect.

6.4 Setting mode

Pressing the **SET** key for 2 seconds to enter setting model,the basic settings can now be performed in the following order:

6.4.1 BEEP



- Press the **SET** key for 2 seconds to select the beep section, ON/OFF section digits will start flashing, press the **WIND/+** or **PRESSURE/-** key to select ON or OFF.

“BEEP ON” will make the Beep sound on every key press. If you do not want the beep sound to be heard, select “BEEP OFF”

6.4.2 MAX/MIN Daily



- Press the **SET** key twice to select the **MAX/MIN Daily** section, ON/OFF section digits will start flashing,press the **WIND/+** or **PRESSURE/-** key to select ON or OFF . (Default is ON,ON: clear at 0:00 every day).

6.4.3 DST(daylight saving time)



- Press the **SET** key third time to select the **Daylight saving time** section, ON/OFF section

digits will start flashing,press the **WIND/+** or **PRESSURE/-** key to select ON or OFF .
(default ON, only WWVB)

6.4.4 Time zone



- Press the **SET** key fourth time to select the **Time zone** section, time zone section digits will start flashing,press the **WIND/+** or **PRESSURE/-** key to select the value . (level: -12 to +12,default: -5)

6.4.5 Time / Date

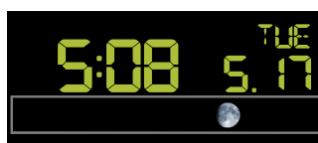

- Press the **SET** key fifth time to select the 12/24 hour format section (default: 24hr).
- Press the **SET** key sixth time to select the hour section.
- Press the **SET** key seventh time to select the minutes section.
- Press the **SET** key eighth time to select DD-MM or MM-DD format. (Default DD-MM format)
- Press the **SET** key ninth time to select year.
- Press the **SET** key tenth time to select month.
- Press the **SET** key again time to select day.

Note: Press the **WIND/+** or **PRESSURE/-**key to set the value.

Note: If user to change minute value, second will auto clear to 0.

6.4.6 Pressure



- Press the **SET** key 12th to select ABS. Pressure unit (hpa, mmhg or inhg;default: hpa).
- Press the **SET** key 13th to select REL. Pressure value.

Note: Press the **WIND/+** or **PRESSURE/-** key to select the value.

Note: in normal mode,press and release the **PRESSURE/-** key to view the average of 12hr, 24hr, 48hr and 72hr pressure. Press and hold 2s the **PRESSURE/-** key to view the absolute and relative pressure

6.4.7 Light



- Press the **SET** key 14th to select light unit (lux, fc, w/m2;default: w/m2).

6.4.8 Temperature



- Press the **SET** key 15th to select in/outdoor temperature unit (C or F;default: C).
- In normal model,press the **TEMP.** key to view wind Chill, Heat Index, Dew Point Temperature. Press the **TEMP.** key for 5 second, will register new transmitter.

Note: every 60 second the unit will measure indoor temperature, indoor humidity and pressure. If temperature is to lower than minimum range, will display --., if it is higher than highest range, will display --.-.

6.4.9 Wind speed



- Press the **SET** key 16th to select wind speed unit (km/h, mph, knots, m/s, bft;default: km/h).
- In normal mode,press and release the **WIND/+** key to view the wind, gust and wind direction.

6.4.10 Rain



- Press the **SET** key 17th to select rainfall unit (in/mm; default: mm).
- In normal mode,press and release the RAIN key to view rain of rate, event, day, week, month and total.
- Press the **RAIN** key for 2 seconds to reset current display rain.

Note:

- Reset week rain, will auto reset day rain
- Reset month rain, will auto reset week and day rain.
- Reset total rain, will auto reset month, week and day rain.

Note:

- Rain rate: the last 10 minutes rainfall multiplication 6.
- Rain event: when rainfall, begin the rain event, if one day (00:00-24:00) not rainfall or rainfall less 10 mm, the rain event is over.
- Day: defined by calendar day i.e. 0:00 - 24:00 with current date.

Week: defined by calendar week i.e. Sunday – Saturday.

Month: defined by calendar Month i.e. January 1 - January 31.

Total: running total since station was powered up

Note: the transmitter will send the wind speed, wind direction, rainfall every 16 second

6.4.11 Moon phase



- Press the **SET** key 18th to select Northern or Southern Hemisphere

6.5 Alarm mode

6.5.1 Display of Alarm value

1) Press and release **ALARM** key to display high alarm



2) Press **ALARM** key again to display low alarm



Note:

- Press **RAIN** key to select display rate or day rain alarm data.
- Press **WIND/+** key to select display wind or gust alarm data.
- Press **ALARM** key third time or press **LIGHT /SNOOZE** key back to normal mode

6.5.2 Alarm mode setting

- 1) Press and hold for 2 seconds **ALARM** key enter alarm setting mode:
- 2) Press the **WIND/+** or **PRESSURE/-** to arm/disarm alerts and adjust alert values.
- 3) Press the **SET** key to confirm & move to the next item.
- 4) Press the **ALARM** key to on/off the alarm

Note: when alert is triggered, the current triggering source  icon for time,  icon for

high value and  icon for low value will be flashing, indicating alert is triggered.

Note: press **ALARM** key third time back to normal mode or press **LIGHT /SNOOZE** key back to normal mode.

6.5.3 Alarm Setting Order

- 1) Time alarm setting
- 2) Indoor high temperature setting
- 3) Indoor low temperature setting
- 4) Indoor high humidity setting
- 5) Indoor low humidity setting
- 6) Outdoor high temperature setting
- 7) Outdoor low temperature setting
- 8) Outdoor high humidity setting
- 9) Outdoor low humidity setting
- 10) High wind setting
- 11) High gust setting
- 12) Rain rate high setting
- 13) Rain day high setting

6.6 Max/min mode

6.6.1 Press and release **MAX/MIN** key to display MAX data



- Press **TEMP.** key to view wind chill, heat index and dew point max.
- Press **RAIN** key to view rain rate, rain day, rain week and rain month max.
- Press **WIND/+** to view wind and gust max.
- Press **PRESSURE/-** to hold 2 seconds to view pressure absolute and relative max.

6.6.2 Press again to display min data



- Press **TEMP.** key to view wind chill and dew point min.
- Press **PRESSURE/-** to hold 2 seconds to view pressure absolute and relative min.

Note: press and hold 2s MAX/MIN button to reset all max or min.

press **MAX/MIN** key third time back to normal mode or press **LIGHT /SNOOZE** key back to normal mode.

6.7 Calibration mode

Hold the **TEMP.** and **MAX/MIN** key together for 5 seconds to enter calibration mode.



- Press the **WIND/+** and **PRESSURE/-** key to adjust values.
- Press the **SET** key to confirm & move to the next item.
- Press the **ALARM** key to reset any adjusted value.
- Press the **LIGHT /SNOOZE** key at any time to exit.

6.7.1 Calibration Order

- 1) Indoor temperature offset calibrated (range +/-9F, default: 0 degrees)
- 2) Indoor humidity offset calibrated (range +/-9%)
- 3) Outdoor temperature offset calibrated (range +/-9F, default: 0 degrees)
- 4) Outdoor humidity offset calibrated (range +/-9%)
- 5) Absolute pressure offset calibrated (range +/-10hpa)
- 6) Wind direction offset calibrated (adjust by degree)
- 7) Wind speed factor adjust, default 100% (range 50% to 150%)
- 8) Rain factor adjust, default 100% (range 50% to 150%)

6.8 Other Features

6.8.1 Factory Reset/Clear Memory

- 1) When power on, press **TEMP.** key to skip receive RF signal.
- 2) When power on, full display after press **WIND/+** and **PRESSURE/-** key to reset the weather station and clear all records memory, and clears all user settings to default.
- 3) Press the **LIGHT /SNOOZE** key for 5 seconds, will register new transmitter.

6.8.2 Backlight (constant backlight requires operation with DC adapter.



- 1) with AC adaptor.
Press **LIGHT /SNOOZE** key to change the LCD backlight brightness: HI/MID/OFF
- 2) without DC adaptor

In normal mode for 15 seconds without touch keys into sleep mode, the backlight will be closed, the touch keys will be disabled.

- 3) Hold the **LIGHT /SNOOZE** key in sleep mode or plug in the DC adapter wake up equipment. (You must hold the **LIGHT /SNOOZE** key waiting for backlight light to loosen the button)

6.8.3 Tendency indicators

- 3 hrs comparison which changes on every ½ hour
- Eg. : At 3:00 - compare to 12:00 data; at 3:30 -compare to 12:30 etc

Tendency indicators		Humidity	Temperature	Pressure
	Rising	Rising > 3%	Rising >= 1C/2F	Rising > 1hpa
	Steady	Change <= 3%	Change < 1C/2F	Change <= 1hpa
	Falling	Falling > 3%	Falling >= 1C/2F	Falling > 1hpa

6.8.4 Wireless Signal Strength Indicator

During the synchronization, it will reduce one signal segment if it has not received the signal once from the transmitter. It will increase one signal segment if it has received the signal once.

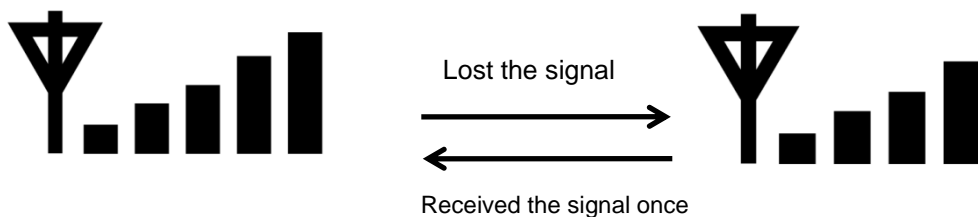

6.8.5 Weather forecast: Sunny, Partly sunny, Cloudy, Rainy, Stormy and Snowy

When Outdoor temperature is below 32 F (0 C) and the forecast is RAINY or STORMY, the LCD will display SNOWY.

6.8.6 Snooze

When time alarming, press **LIGHT /SNOOZE** key to snooze time alarm mode, press other key exit snooze mode.

In snooze mode after 10 minutes the alarm again.

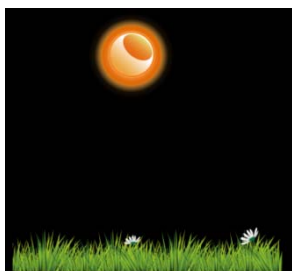

Sunny

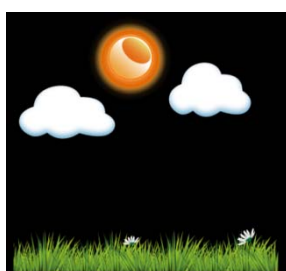

Partly sunny

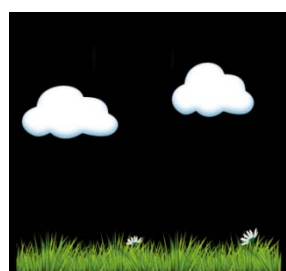

Cloudy



Rainy



Snowy

7. WIFI connection setting on mobile

When connect to WIFI, not measuring the indoor temperature, and receive the indoor transmitter replace it.

If connect WIFI module, must power by DC, otherwise the WIFI not work.

WIFI only support upload the current data to weather server and time will be Internet time.

7.1 Weather server

The weather station sends data to three free hosting services:

Hosting Service	Website	Description
Weather Underground	WeatherUndeground.com	Weather Underground is a free weather hosting service that allows you to send and view your weather station data real-time, view graphs and gauges, import text data for more detailed analysis and use iPhone, iPad and Android applications available at Wunderground.com. Weather Underground is a subsidiary of The Weather Channel and IBM.
WeatherBug Community	backyard.weatherbug.com	WeatherBug Community is an extension of the WeatherBug community of weather stations. WeatherBug is a brand owned by Earth Networks that provides live weather data and maintains a mesoscale network of over 8,000 weather stations.
Weather Cloud	WeatherCloud.net	Weathercloud is a real-time weather social network formed by observers from around the world.

7.2 Connecting the Weather Station Console to WiFi

The WiFi feature only works when plugged into AC power due to higher energy requirements.

To connect the weather station to WiFi, you must first download the application from one of the following choices:

- Apple App Store
- Google Play Store

1. From your mobile device, visit the Apple App Store or Google Play Store and search for the “**WS Tool**” application. Download this application to your mobile device.
2. Run the weather station application, and select **Add Device**.

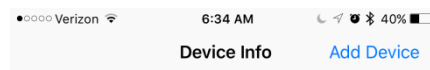

3. Make sure your mobile device is connected to your WiFi network. Enter the password for your router, and select **Save**.

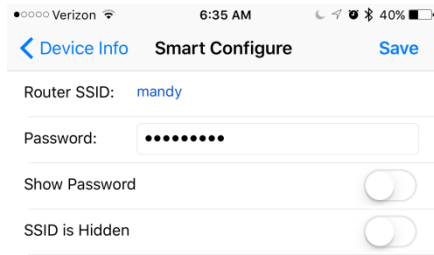

4. Reference below picture. If the WiFi icon is not flashing rapidly, (1) press and hold the **RAIN** and **ALARM** buttons at the same time for four seconds. (2) The WiFi icon will begin flashing rapidly, indicating the console is searching for your WiFi network.



5. Once the console has connected to your WiFi network, the devices Mac address and IP address will be displayed.



6. Enter your Wunderground.com and WeatherCloud.net Station ID, Password and StationNum (see Section 8).

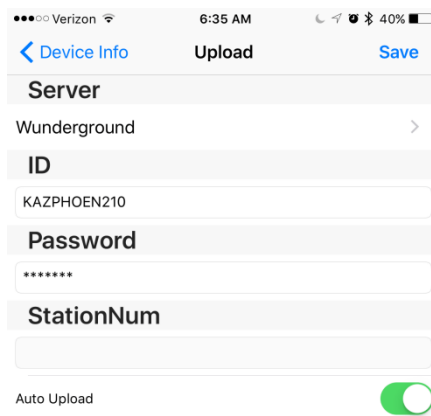

7.3 Registering with WeatherUnderground.com, WeatherBug.com and WeatherCloud.net

7.3.1 WeatherUnderground.com

Visit Wunderground.com and select the **Join** link at the top of the page. Select the **Free** sign up option.

1

2

1. Select **More | Register Your PWS**.
2. Click **Send Validation Email**. Respond to the validation email from Wunderground (it may take a few minutes).

3

4

3. Select **More | Register Your PWS** again and enter all of the information requested.

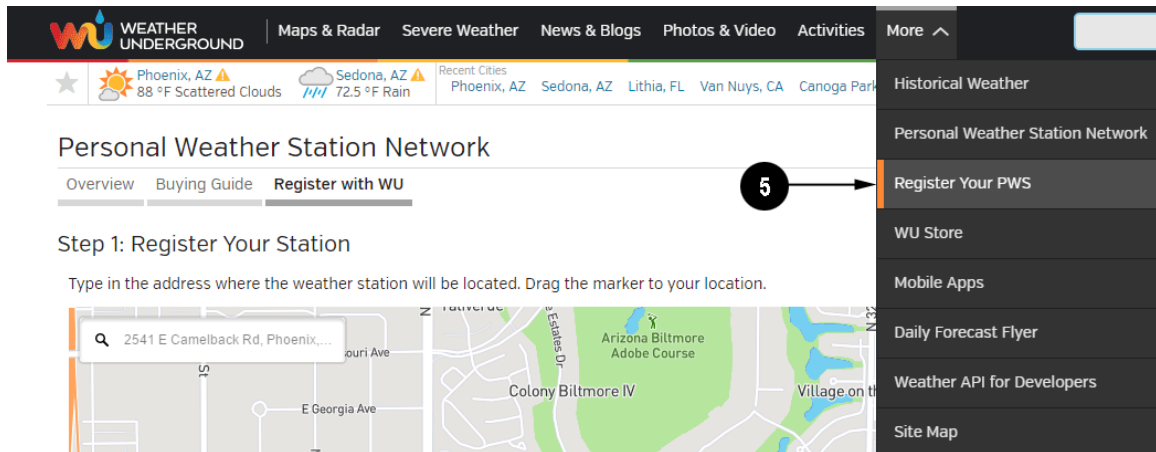

4. After registering your station, make a note of the following:
 - Station ID
 - Station Key / Password

Enter the Station ID (ID), Station Key (Password) and Station Number (StationNum) into the Ambient Tool. Leave the StationNum field blank.

Following picture is an example, and your station ID and password will be different.

Congratulations. Your station is now registered with Wunderground!

You are almost done. Now go to your weather station software and add the following:

Your Station ID:
KAZPHOEN424
 Your Station Key/Password:
mdreeley

Note: Your station ID will have the form: KSSCCCC###, where K is for USA station (I for international), SS is your state, CCCC is your city and ### is the station number in that city.

In the example above, KAZPHOEN424 is in the USA (K), State of Arizona (AZ), City of Phoenix (PHOEN) and #424.

7.3.2 WeatherBug.com

Visit <http://pws.ensb.us/> and [Click here](#) to register your station.

REGISTRATION

Please enter your personal information: (** Required Fields) [Log In](#)

****First Name:** ****Last Name:**
****Country:**
****Address:** **Apt./Unit Number:**
****City:** **** State or Province:** ****ZIP/Postal Code:**
****Email Address:** ****Confirm Email Address:**

****Telephone Number:** - -

[Create a personal Login and Password](#)
 (This login information will allow you to access exclusive features and change your registration information at any time)

****Login Name:**
****Password:** (minimum 5 characters) ****Confirm Password:**

Please enter your Personal Weather Station information:
****Create a name for your Personal Weather Station:** (example: Bob's Station)

Location of your Personal Weather Station **Yard** ▼

****Latitude** Deg Min Sec North South [Find Location on Map](#)
****Longitude** Deg Min Sec East West
****Elevation**

Personal Weather Type: **Basic** ▼ Internet Connection: **Broadband** ▼

Note: Once Form is submitted, any changes can be made by re-opening the Registration Form, making updates and re-submitting the form. You can also contact WeathBug by clicking the Help button on the top of the main screen or by visiting www.weatherbug.com and clicking the SUPPORT link

Figure 34

After registering your station, make a note of the following:

- Username
- Password
- Your Publisher ID
- Your Station Number

Enter the Publisher ID (ID), Password and Station Number (StationNum) into the Ambient Tool.

7.3.3 WeatherCloud

1. Visit WeatherCloud.net and enter a Username, Email and Password.



2. Respond to the validation email from WeatherCloud (it may take a few minutes).

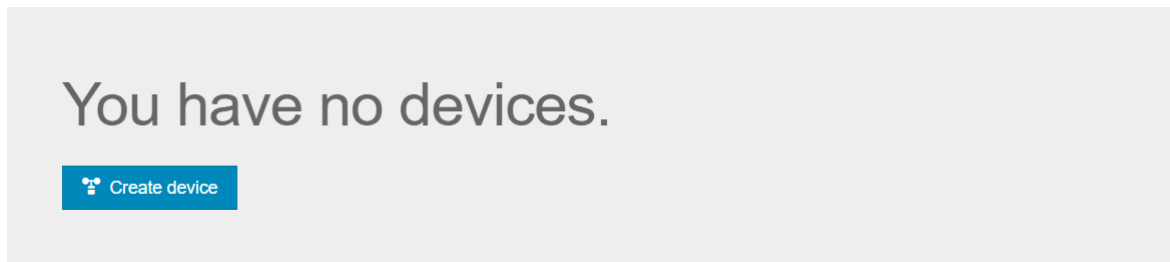

3. Select **Create Device** and enter your weather station information. After registering your station, make a note of the following:

- Weathercloud ID
- Key

Enter the Weathercloud ID (ID), Key (password) into the Ambient Tool. Leave the Station Number (StationNum) blank.

8. Glossary of Terms

Term	Definition
Absolute Barometric Pressure	Absolute pressure is the measured atmospheric pressure and is a function of altitude, and to a lesser extent, changes in weather conditions. Absolute pressure is not corrected to sea-level conditions. <i>Refer to Relative</i>

Term	Definition
	<i>Barometric Pressure.</i>
Accuracy	Accuracy is defined as the ability of a measurement to match the actual value of the quantity being measured.
Barometer	A barometer is an instrument used to measure atmospheric pressure.
Calibration	Calibration is a comparison between measurements – one of known magnitude or correctness of one device (standard) and another measurement made in as similar a way as possible with a second device (instrument).
Dew Point	<p>The dew point is the temperature at which a given parcel of humid air must be cooled, at constant barometric pressure, for water vapor to condense into water. The condensed water is called dew. The dew point is a saturation temperature.</p> <p>The dew point is associated with relative humidity. A high relative humidity indicates that the dew point is closer to the current air temperature. Relative humidity of 100% indicates the dew point is equal to the current temperature and the air is maximally saturated with water. When the dew point remains constant and temperature increases, relative humidity will decrease.</p>
Heat Index	<p>The Heat Index, sometimes referred to as the apparent temperature, is a measure of how hot it really feels when relative humidity is factored with the actual air temperature.</p> <p>To find the Heat Index temperature, look at the Heat Index chart below. As an example, if the air temperature is 35°C and the relative humidity is 65%, the heat index (how hot it feels) is 49°C.</p> <p>IMPORTANT: Since heat index values were devised for shady, light wind conditions, exposure to full sunshine can increase heat index values by up to -9°C. Also, strong winds, particularly with very hot, dry air, can be extremely hazardous.</p> <p>The Heat Index Chart shaded zone above 40°C shows a level that may cause increasingly severe heat disorders with continued exposure or physical activity.</p> <p>Heat Index is not calculated below 26°C.</p>

Term	Definition																																																																																																																																																																																																																																																						
	<div style="display: flex; align-items: center;"> <table border="1" style="margin-right: 20px;"> <caption style="text-align: center; color: red;">Relative Humidity (%)</caption> <thead> <tr> <th style="color: red;">°F</th> <th>40</th> <th>45</th> <th>50</th> <th>55</th> <th>60</th> <th>65</th> <th>70</th> <th>75</th> <th>80</th> <th>85</th> <th>90</th> <th>95</th> <th>100</th> </tr> </thead> <tbody> <tr><td>110</td><td>136</td><td></td><td></td><td></td><td></td><td></td><td></td><td></td><td></td><td></td><td></td><td></td><td></td></tr> <tr><td>108</td><td>130</td><td>137</td><td></td><td></td><td></td><td></td><td></td><td></td><td></td><td></td><td></td><td></td><td></td></tr> <tr><td>106</td><td>124</td><td>130</td><td>137</td><td></td><td></td><td></td><td></td><td></td><td></td><td></td><td></td><td></td><td></td></tr> <tr><td>104</td><td>119</td><td>124</td><td>131</td><td>137</td><td></td><td></td><td></td><td></td><td></td><td></td><td></td><td></td><td></td></tr> <tr><td>102</td><td>114</td><td>119</td><td>124</td><td>130</td><td>137</td><td></td><td></td><td></td><td></td><td></td><td></td><td></td><td></td></tr> <tr><td>100</td><td>109</td><td>114</td><td>118</td><td>124</td><td>129</td><td>136</td><td></td><td></td><td></td><td></td><td></td><td></td><td></td></tr> <tr><td>98</td><td>105</td><td>109</td><td>113</td><td>117</td><td>123</td><td>128</td><td>134</td><td></td><td></td><td></td><td></td><td></td><td></td></tr> <tr><td>96</td><td>101</td><td>104</td><td>108</td><td>112</td><td>116</td><td>121</td><td>126</td><td>132</td><td></td><td></td><td></td><td></td><td></td></tr> <tr><td>94</td><td>97</td><td>100</td><td>103</td><td>106</td><td>110</td><td>114</td><td>119</td><td>124</td><td>129</td><td>135</td><td></td><td></td><td></td></tr> <tr><td>92</td><td>94</td><td>96</td><td>99</td><td>101</td><td>105</td><td>108</td><td>112</td><td>116</td><td>121</td><td>126</td><td>131</td><td></td><td></td></tr> <tr><td>90</td><td>91</td><td>93</td><td>95</td><td>97</td><td>100</td><td>103</td><td>106</td><td>109</td><td>113</td><td>117</td><td>122</td><td>127</td><td>132</td></tr> <tr><td>88</td><td>88</td><td>89</td><td>91</td><td>93</td><td>95</td><td>98</td><td>100</td><td>103</td><td>106</td><td>110</td><td>113</td><td>117</td><td>121</td></tr> <tr><td>86</td><td>85</td><td>87</td><td>88</td><td>89</td><td>91</td><td>93</td><td>95</td><td>97</td><td>100</td><td>102</td><td>105</td><td>108</td><td>112</td></tr> <tr><td>84</td><td>83</td><td>84</td><td>85</td><td>86</td><td>88</td><td>89</td><td>90</td><td>92</td><td>94</td><td>96</td><td>98</td><td>100</td><td>103</td></tr> <tr><td>82</td><td>81</td><td>82</td><td>83</td><td>84</td><td>84</td><td>85</td><td>86</td><td>88</td><td>89</td><td>90</td><td>91</td><td>93</td><td>95</td></tr> <tr><td>80</td><td>80</td><td>80</td><td>81</td><td>81</td><td>82</td><td>82</td><td>83</td><td>84</td><td>84</td><td>85</td><td>86</td><td>86</td><td>87</td></tr> </tbody> </table> <div style="margin-right: 20px;"> <p style="color: red; transform: rotate(-90deg); font-weight: bold;">Air Temperature</p> <div style="border: 1px solid black; padding: 5px; display: inline-block;">Heat Index (Apparent Temperature)</div> </div> <div style="border: 1px solid black; padding: 5px;"> <p style="color: red; font-weight: bold;">With Prolonged Exposure and/or Physical Activity</p> <table border="1" style="width: 100%; text-align: center;"> <tr><td style="background-color: #800000; color: white; font-weight: bold;">Extreme Danger</td></tr> <tr><td style="text-align: center;">Heat stroke or sunstroke highly likely</td></tr> <tr><td style="background-color: #FF8C00; color: white; font-weight: bold;">Danger</td></tr> <tr><td style="text-align: center;">Sunstroke, muscle cramps, and/or heat exhaustion likely</td></tr> <tr><td style="background-color: #FFD700; color: black; font-weight: bold;">Extreme Caution</td></tr> <tr><td style="text-align: center;">Sunstroke, muscle cramps, and/or heat exhaustion possible</td></tr> <tr><td style="background-color: #FFFF00; color: black; font-weight: bold;">Caution</td></tr> <tr><td style="text-align: center;">Fatigue possible</td></tr> </table> </div> </div>	°F	40	45	50	55	60	65	70	75	80	85	90	95	100	110	136													108	130	137												106	124	130	137											104	119	124	131	137										102	114	119	124	130	137									100	109	114	118	124	129	136								98	105	109	113	117	123	128	134							96	101	104	108	112	116	121	126	132						94	97	100	103	106	110	114	119	124	129	135				92	94	96	99	101	105	108	112	116	121	126	131			90	91	93	95	97	100	103	106	109	113	117	122	127	132	88	88	89	91	93	95	98	100	103	106	110	113	117	121	86	85	87	88	89	91	93	95	97	100	102	105	108	112	84	83	84	85	86	88	89	90	92	94	96	98	100	103	82	81	82	83	84	84	85	86	88	89	90	91	93	95	80	80	80	81	81	82	82	83	84	84	85	86	86	87	Extreme Danger	Heat stroke or sunstroke highly likely	Danger	Sunstroke, muscle cramps, and/or heat exhaustion likely	Extreme Caution	Sunstroke, muscle cramps, and/or heat exhaustion possible	Caution	Fatigue possible
°F	40	45	50	55	60	65	70	75	80	85	90	95	100																																																																																																																																																																																																																																										
110	136																																																																																																																																																																																																																																																						
108	130	137																																																																																																																																																																																																																																																					
106	124	130	137																																																																																																																																																																																																																																																				
104	119	124	131	137																																																																																																																																																																																																																																																			
102	114	119	124	130	137																																																																																																																																																																																																																																																		
100	109	114	118	124	129	136																																																																																																																																																																																																																																																	
98	105	109	113	117	123	128	134																																																																																																																																																																																																																																																
96	101	104	108	112	116	121	126	132																																																																																																																																																																																																																																															
94	97	100	103	106	110	114	119	124	129	135																																																																																																																																																																																																																																													
92	94	96	99	101	105	108	112	116	121	126	131																																																																																																																																																																																																																																												
90	91	93	95	97	100	103	106	109	113	117	122	127	132																																																																																																																																																																																																																																										
88	88	89	91	93	95	98	100	103	106	110	113	117	121																																																																																																																																																																																																																																										
86	85	87	88	89	91	93	95	97	100	102	105	108	112																																																																																																																																																																																																																																										
84	83	84	85	86	88	89	90	92	94	96	98	100	103																																																																																																																																																																																																																																										
82	81	82	83	84	84	85	86	88	89	90	91	93	95																																																																																																																																																																																																																																										
80	80	80	81	81	82	82	83	84	84	85	86	86	87																																																																																																																																																																																																																																										
Extreme Danger																																																																																																																																																																																																																																																							
Heat stroke or sunstroke highly likely																																																																																																																																																																																																																																																							
Danger																																																																																																																																																																																																																																																							
Sunstroke, muscle cramps, and/or heat exhaustion likely																																																																																																																																																																																																																																																							
Extreme Caution																																																																																																																																																																																																																																																							
Sunstroke, muscle cramps, and/or heat exhaustion possible																																																																																																																																																																																																																																																							
Caution																																																																																																																																																																																																																																																							
Fatigue possible																																																																																																																																																																																																																																																							
HectoPascals (hPa)	Pressure units in SI (international system) units of measurement. Same as millibars (1 hPa = 1 mbar)																																																																																																																																																																																																																																																						
Hygrometer	A hygrometer is a device that measures relative humidity. Relative humidity is a term used to describe the amount or percentage of water vapor that exists in air.																																																																																																																																																																																																																																																						
Inches of Mercury (inHg)	Pressure in Imperial units of measure. 1 inch of mercury = 33.86 millibars																																																																																																																																																																																																																																																						
Rain Gauge	<p>A rain gauge is a device that measures liquid precipitation (rain), as opposed to solid precipitation (snow gauge) over a set period of time.</p> <p>All digital rain gauges are self emptying or self dumping (also referred to as tipping rain gauge). The precision of the rain gauge is based on the volume of rain per emptying cycle.</p>																																																																																																																																																																																																																																																						
Range	Range is defined as the amount or extent a value can be measured.																																																																																																																																																																																																																																																						
Relative Barometric Pressure	Measured barometric pressure relative to your location or ambient conditions.																																																																																																																																																																																																																																																						
Resolution	Resolution is defined as the number of significant digits (decimal places) to which a value is being reliably measured.																																																																																																																																																																																																																																																						
Solar Radiation	<p>A solar radiation sensor measures solar energy from the sun.</p> <p>Solar radiation is radiant energy emitted by the sun from a nuclear fusion reaction that creates electromagnetic energy. The spectrum of solar radiation is close to that of a black body with a temperature of about 5800 K. About half of the radiation is in the visible short-wave part of the electromagnetic spectrum. The other half is mostly in the near-infrared part, with some in the ultraviolet part of the spectrum.</p>																																																																																																																																																																																																																																																						

Term	Definition
Thermometer	A thermometer is a device that measures temperature. Most digital thermometers are resistive thermal devices (RTD). RTDs predict change in temperature as a function of electrical resistance.
Wind Vane	A wind vane is a device that measures the direction of the wind. The wind vane is usually combined with the anemometer. Wind direction is the direction from which the wind is blowing.

9. Specification

Outdoor data

Transmission distance in open field :	100m(330 feet)
Frequency :	433/868/915 MHz
Temperature range :	-25°C to +60°C (-14°F to + 140°F)
Accuracy :	+ / - 1°C
Resolution :	0.1°C
Measuring range rel. humidity :	10%~99%
Accuracy :	+/- 5%
Rain volume display :	0 – 6000mm (show --- if outside range)
Accuracy :	+ / - 10%
Resolution :	0.1in (if rain volume < 1000mm) 1mm (if rain volume > 1000mm)
Wind speed :	0-50m/s (0~100mph) (show --- if outside range)
Accuracy:	+/- 1m/s (wind speed< 5m/s) +/-10% (wind speed > 5m/s)
Light :	0-400k Lux
Accuracy :	+/-15%
Measuring interval outdoor sensor:	16 sec

Indoor data

Indoor temperature range :	-10°C--60°C (14°F to + 140°F) (show --- if outside range)
Resolution :	0.1°C
Measuring range rel. humidity :	10%~99%
Resolution :	1%
Measuring range air pressure :	300-1100hPa (8.85-32.5inHg)
Accuracy :	+/-3hpa under 700-1100hPa
Resolution :	0.1hPa (0.01inHg)
Alarm duration :	120 sec

10. Power Consumption

- Base station : 5V DC Adaptor (included), Power Consumption: 0.5 Watts (1.25 Watts during WiFi configuration mode)
- Outdoor sensor array: 3xAA batteries (not included)

11. Maintenance

1. Clean the rain gauge once every 3 months. Rotate the funnel counter-clockwise and lift to expose the rain gauge mechanism, and clean with a damp cloth. Remove any dirt, debris and insects. If bug infestation is an issue, spray the array lightly with insecticide.

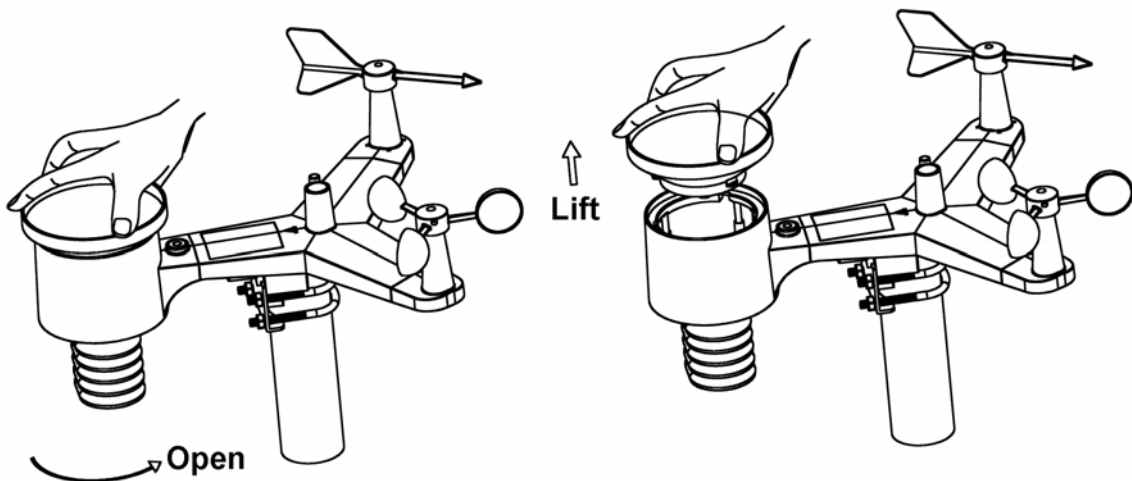

2. Clean the solar radiation sensor and solar panel every 3 months with damp cloth.
3. Replace batteries every 1-2 years. If left in too long, the batteries may leak due to environmental challenges.
4. In snowy environments, spray the top of the weather station with anti-icing silicon spray to prevent snow build up.

12. Troubleshooting Guide

Problem	Solution
Outdoor sensor array does not communicate to the display console.	The sensor array may have initiated properly and the data is registered by the console as invalid, and the console must be reset. Press the reset button as described in Figure 1. With an open ended paperclip, press the reset button for 3 seconds to

Problem	Solution
	<p>completely discharge the voltage.</p> <p>Take out the batteries and wait one minute, while covering the solar panel to drain the voltage.</p> <p>Put batteries back in and resync the console (Section 6.12) with the sensor array about 10 feet away.</p> <p>The LED next to the battery compartment will flash every 16 seconds. If the LED is not flashing every 16 seconds...</p> <p>Replace the batteries in the outside sensor array.</p> <p>If the batteries were recently replaced, check the polarity. If the sensor is flashing every 16 seconds, proceed to the next step.</p> <p>There may be a temporary loss of communication due to reception loss related to interference or other location factors,</p> <p>or the batteries may have been changed in the sensor array and the console has not been reset. The solution may be as simple as powering down and up the console (remove AC power and batteries, wait 10 seconds, and reinsert AC power and batteries).</p>
<p>Temperature sensor reads too high in the day time.</p>	<p>Make certain that the sensor array is not too close to heat generating sources or strictures, such as buildings, pavement, walls or air conditioning units.</p> <p>Use the calibration feature to offset installation issues related to radiant heat sources. Reference Section 6.10.</p>
<p>Relative pressure does not agree with official reporting station</p>	<p>You may be viewing the absolute pressure, not the relative pressure.</p> <p>Select the relative pressure. Make sure you properly calibrate the sensor to an official local weather station. Reference Section 6.4 for details.</p>
<p>Rain gauge reports rain when it is not raining</p>	<p>An unstable mounting solution (sway in the mounting pole) may result in the tipping bucket incorrectly incrementing rainfall. Make sure you have a stable, level mounting solution.</p>
<p>Data not reporting to Wunderground.com</p>	<ol style="list-style-type: none"> 1. Confirm your password or key is correct. It is the password you registered on Wunderground.com. Your Wunderground.com password cannot begin with a non-alphanumeric character (a limitation of Wunderground.com, not the station). Example, \$oewkrf is not a valid password, but oewkrf\$ is valid.

Problem	Solution
	<ol style="list-style-type: none"> <li data-bbox="571 282 1362 398">2. Confirm your station ID is correct. The station ID is all caps, and the most common issue is substituting an O for a 0 (or visa versa). Example, KAZPHOEN11, not KAZPH0EN11 <li data-bbox="571 450 1362 521">3. Make sure the date and time is correct on the console. If incorrect, you may be reporting old data, not real time data. <li data-bbox="571 573 1401 645">4. Make sure your time zone is set properly. If incorrect, you may be reporting old data, not real time data. <li data-bbox="571 696 1362 768">5. Check your router firewall settings. The console sends data via Port 80.
No WiFi connection	<ol style="list-style-type: none"> <li data-bbox="571 819 1401 972">1. Check for WiFi symbol on the display. If wireless connectivity is successful the WiFi icon  will be displayed in the time field. <li data-bbox="571 1023 1350 1095">2. Make sure your modem WiFi settings are correct (network name, and password).