

The Leading Enterprise Internet of Things Solution

## Wireless Hydrogen Sulfide (H<sub>2</sub>S) Sensor

### General Description

Hydrogen Sulfide (H<sub>2</sub>S) is a highly toxic gas similar to carbon monoxide. This sensor from Monnit allows you to monitor the air and presence of H<sub>2</sub>S in the surrounding environment.

The small footprint and affordability makes Monnit sensors the industry standard for H<sub>2</sub>S detection. Monnit sensors are the longest lasting and most efficient devices on the market.

- Measures H<sub>2</sub>S levels in surrounding air.



Free iMonnit basic online wireless sensor monitoring and notification system to configure sensors, view data and set alerts via SMS text and email.

### Principle of Operation

ALTA Wireless Hydrogen Sulfide (H<sub>2</sub>S) Sensors monitor the presence of toxic gas in the atmosphere. Combined with the iMonnit Online System, the sensor will deliver up to date readings to notify you the second gas levels breach a set threshold. Readings can be viewed online through graphs and downloadable spreadsheets. Event notifications can be set in iMonnit through the easy to use online interface available on mobile devices.

### Example Applications

- Crude oil production
- Natural gas production
- Wastewater treatment
- Utility facilities
- Sewers

And many more...

### Features of Monnit ALTA Sensors

- Wireless range of 1,200+ feet through 12+ walls \*
- Frequency-Hopping Spread Spectrum (FHSS)
- Improved interference immunity
- Improved power management for longer battery life \*\* (12+ years on AA batteries)
- Encrypt-RF® Security (Diffie-Hellman Key Exchange + AES-128 CBC for sensor data messages)
- Onboard data memory stores up to 512 readings per sensor:
  - 10-minute heartbeats = 3.5 days
  - 2-hour heartbeats = 42 days
- Over-the-air updates (future proof)
- Free iMonnit basic online wireless sensor monitoring and notification system to configure sensors, view data and set alerts via SMS text and email

- \* Actual range may vary depending on environment.
- \*\* Battery life is determined by sensor reporting frequency and other variables. Other power options are also available.

### Wireless Range Comparison

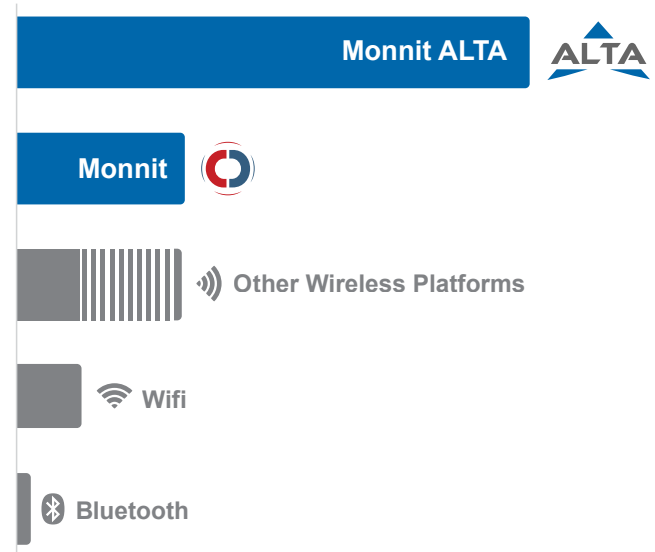

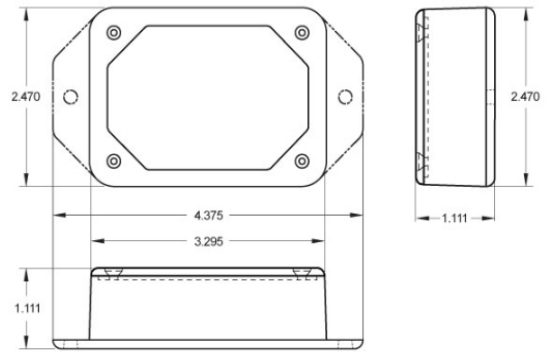

## ALTA Commercial AA Wireless Hydrogen Sulfide (H<sub>2</sub>S) Sensor | Technical Specifications

Supply Voltage	2.0 - 3.8 VDC (2 x AA 1.5V Batteries or Optional Power Supply) *
Current Consumption	0.7 $\mu$ A (sleep mode) 2 mA (radio idle/off mode) 2 mA (measurement mode) 25 mA (radio RX mode) 35 mA (radio TX mode)
Operating Temperature Range (Board Circuitry and Batteries)	-18°C to 55°C (0°F to 130°F) using alkaline -40°C to 60°C (-40°F to 140°F) using lithium **
Optimal Battery Temperature Range (AA)	+10°C to +50°C ( 50°F to +122°F )
Operating Pressure Range	$\pm$ 0.2 atm (recommended)
Operating Humidity Range	15 to 85% RH
Measuring Range	0-50 PPM
Maximum Overload	50 PPM
Measuring Principle	Electrochemical reaction of H <sub>2</sub> S.
Resolution	$\pm$ 0.1 PPM
Response Time (t-90)	< 40 seconds typical at 20°C
Stabilization Time	< 120 seconds
Long Term Drift – Zero	Zero Signal $\leq$ $\pm$ 2 PPM / month
Long Term Drift – Span	Output Signal $\leq$ $\pm$ 2% of reading per month
Maximum Zero Shift	< 1 ppm equivalent (-20°C to +40°C)
Weight	4.0 oz.
Wireless Range	1,200+ ft. non-line-of-sight
Certifications	900 MHz product; FCC ID: ZTL- RFSC1 and IC: 9794A-RFSC1. 920 MHz product; ARIB STD-T108 R210-103733. 868 and 433 MHz product tested and found to comply with: CISPR 22:2008-09 / EN 55022:2010 - Class B and ETSI EN 300 220-2 V2.4.1 (2012-05).



\* Circuits cannot withstand negative voltage. Please take care when installing batteries.

### Power Options

The standard version of this sensor is powered by two replaceable 1.5 V AA sized batteries (included with purchase).

This sensor is also available with a line power option. The line powered version of this sensor has a barrel power connector allowing it to be powered by a standard 3.0–3.6 V power supply. The line powered version also uses two standard 1.5 V AA batteries as backup for uninterrupted operation in the event of line power outage.

Power options must be selected at time of purchase, as the internal hardware of the sensor must be changed to support the selected power requirements.

## Notes

### Commercial Grade Sensors

Monnit commercial grade sensors are designed for applications in ordinary environments (normal room temperature, humidity and atmospheric pressure). Do not use these sensors under the following conditions as these factors can deteriorate the product characteristics and cause failures and burn-out.

- Corrosive gas or deoxidizing gas - chlorine gas, hydrogen sulfide gas, ammonia gas, sulfuric acid gas, nitric oxides gas, etc.).
- Volatile or flammable gas.
- Dusty conditions.
- Under low or high pressure.
- Wet or excessively humid locations.
- Places with salt water, oils chemical liquids or organic solvents.
- Where there are excessively strong vibrations.
- Other places where similar hazardous conditions exist.

Use these products within the specified temperature range. Higher temperature may cause deterioration of the characteristics or the material quality.

### Industrial Grade Sensors - Type 1, 2, 4, 4X, 12 and 13 NEMA Rated Enclosure

Monnit's Industrial sensors are enclosed in reliable, weatherproof NEMA rated enclosures. Our NEMA rated enclosures are constructed for both indoor or outdoor use and protect the sensor circuitry against the ingress of solid foreign objects like dust as well as the damaging effects of water (rain, sleet, snow, splashing water, and hose directed water).

- Safe from falling dirt.
- Protects against wind-blown dust.
- Protects against rain, sleet, snow, splashing water, and hose directed water
- Increased level of corrosion resistance
- Will remain undamaged by ice formation on the enclosure

**OneTemp**<sup>®</sup> pty ltd  
MEASURE | CONTROL | RECORD  
[www.onetemp.com.au](http://www.onetemp.com.au)  
1300 768 887

**MONNIT**<sup>®</sup>

Monnit Corporation  
3400 South West Temple  
Salt Lake City, UT 84115  
801-561-5555  
[www.monnit.com](http://www.monnit.com)