

OneTemp^o pty ltd
MEASURE | CONTROL | RECORD

www.onetemp.com.au

1300 768 887



MOISTURE METERS

Portable Sample System

For SDHmini Dewpoint Meters

Instruction Manual

Issue 1



Contents

1	Introduction	3
	1.1 Unpacking Your Shaw Moisture Meters SDH-PSS	3
	1.2 General Description	3
	1.3 General Arrangement Example	4
2	Safety Information	5
	2.1 Explanation of Prohibition, Warning and Note Symbols Used	5
	2.2 Pressure Exposure	5
3	Quick Start Guide - Normal Operation	6
	3.1 Installing the SDHmini into the Portable Sample System	6
	3.2 Connecting a Sample Line	7
4	Purging the Instrument Before Taking a Sample	8
5	Disconnection - Follow This Procedure Exactly	10
6	Filter Replacement (if fitted)	11
7	Sampling Very Dry Gasses and/or at Very Low Pressure	11
8	Cleaning the SDHmini Portable Sample System	11
9	Gases to Avoid	12
10	Guarantee	12
11	Instrument Schematic	13
12	Dimensions	14
13	Specifications	14

1 Introduction

1.1 Unpacking Your Shaw Moisture Meters SDHmini Portable Sample System (SDH-PSS)

Please examine the SDHmini Portable Sample System package for any damage or mishandling. If any damage is evident please notify the carrier and the Shaw Moisture Meters representative from where the unit was purchased.

You should have received (if ordered):

- SDHmini Portable Sample System (with requested configuration)
- Anti-static padded carrying case
- Instruction manual

If anything is missing please contact your distributor immediately.

This instruction manual is only for use with the instrument supplied. All information required for the safe and proper operational use of the instrument is contained here. Please make sure you read and understand the information and instructions in this instruction manual before using the instrument. Failure to operate the instrument as directed in this manual may:

- Expose personnel to risk of injury
- Cause damage to and/or impair the function of the instrument
- Invalidate the instrument warranty

1.2 General Description

The SDHmini Portable Sample System has been specifically designed to condition pressurised gas samples (2900 psi max/200barg, please see specifications for details) for use with the SDHmini dew point meter range.

Although the SDHmini Portable Sample System chassis is constructed from high quality 304 stainless steel, care should be taken when it is in transit and appropriate packaging used.

Do not drop or shock the instrument, especially when a dew point meter is installed to the SDHmini Portable Sample System, as damage could occur to both instruments.

The SDHmini Portable Sample System is provided, as standard, with an anti-static padded carrying case with adjustable shoulder straps and an instruction manual.

Because there are no possible source of ignition or stored energy components, the SDHmini Portable Sample System can be used with the intrinsically safe Model SDHmini-Ex in hazardous environments.

1.3 General Arrangement Example*



* Example shown is a SDH-PSS - R - F - Q - H

2 Safety Information

It is the responsibility of the user to ascertain the suitability of the SDHmini Portable Sample System (SDH-PSS) for use in hazardous areas.

2.1 Explanation of Prohibition, Warning and Note Symbols Used

Local health and safety regulations should be observed as should the safety critical prohibitions, warnings and notes highlighted in this instruction manual.

DO NOT	
	Prohibited actions or behaviours

WARNING	
	Danger to personnel and/or damage to equipment

NOTE	
	Additional information

2.2 Pressure Exposure

The maximum pressure to which the telescopic measuring head is exposed should not be more than 0.3bar, 4psi.

Exposing the measuring head to higher pressures may damage the instrument and result in injury to the operator or other personnel in the area.

3 Quick Start Guide - Normal Operation

Below is a general guide to get started but first ensure that the SDHmini Portable Sample System (SDH-PSS) is located on a flat level and non-slip, safe surface close to the sample point (gas source).

For faster results we recommend the sampling line to be as short as possible to reduce the purging time. Please read this section carefully and understand it.

3.1 Installing the SDHmini into the Portable Sample System

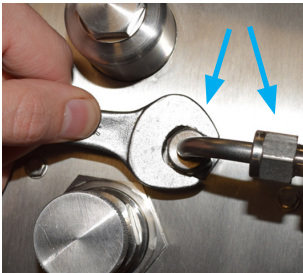

Fig. 1

Connect the SDHmini to the Portable Sample System using the appropriate connecting tubes supplied and ensure a gas tight seal on both sides of the instrument (*Fig. 1*).

The user will need a 14 mm ($\frac{9}{16}$ ") open ended spanner/wrench size and a 16 mm ($\frac{5}{8}$ ") holding spanner/wrench to prevent rotation of the bulkhead fittings.

Ensure the instrument Head is down fully (*Fig. 2*). The instrument Head must be in the down, closed position at this stage.

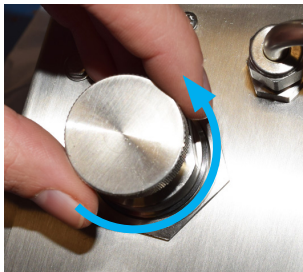

Fig. 3

Ensure that (if fitted) the pressure regulator valve is turned fully anti-clockwise and is fully closed (*Fig. 3*).

If a needle valve is fitted then ensure that this is closed by turning fully clockwise (*Fig. 4*).



Fig. 2



Fig. 4

3.2 Connecting a Sample Line

Before connecting a sample line to the isolation valve at the gas source, first check that the gas to be sampled is free from excessive moisture and/or particle contaminants by placing a white filter paper (or similar) approximately 10 mm from the outlet and slowly opening the isolation valve to achieve a steady flow of gas/air onto the white filter paper for approximately one minute (*Fig. 5*).



Fig. 5

If contaminants are seen on the white filter paper, a filter unit must be installed at the isolation valve outlet and before the sample hose.

When the filter unit is fitted, repeat the above procedure with the white filter cloth. For technical help please contact Shaw Moisture Meters.



Fig. 6

If no contaminants are seen on the white filter paper, close the isolation valve and connect the sample line to the isolation valve and ensure a gas tight seal (*Fig. 6*).

Connect the other end to the SDHmini Portable Sample System (depending on the type of fitting used) and ensure a gas tight seal (*Fig. 7* and *Fig. 8*).

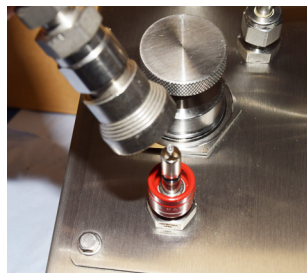

Fig. 7
Sample line to
inlet connection.

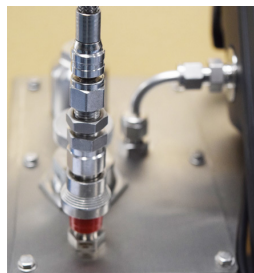

Fig. 8
Quick connect
shown.

4 Purging the Instrument Before Taking a Sample

It is advisable to carry out an initial purge of the sample loop before connecting the instrument in order to avoid the possibility of sensor damage on start up.



Fig. 9

Ensure all pipework is connected and leak tight and that the head is down on the SDHmini.

Open the isolation valve slowly until there is a small flow of air/gas at atmospheric pressure from the pressure reduction valve. (Fig. 9)

Carefully open the pressure regulator valve (Fig. 10) until a flow of 5 to 15 litres per minute can be seen on the flow indicator. (Fig. 11).



Fig. 10



Fig. 11

If a needle valve is fitted, carefully open by turning this anti-clockwise

(Fig. 12) until a flow of 5 to 15 litres per minute can be seen on the flow indicator (Fig. 11).

Allow the air/gas to exhaust through the sample connection.



Fig. 12



Fig. 13

Switch on the SDHmini (Fig. 13) and ensure that the display indicates that the measuring sensor is dry (typically below -70°C dewpoint).

If it does not, please refer to the instrument instruction manual.



Fig. 14

After purging for a minimum of two minutes, place a finger over the vent on the flow indicator until the desiccant head on the instrument is fully raised (Fig. 14).

DO NOT pull the head up (Fig. 15)



Fig. 15

WARNING



Pulling up the head will draw moisture from ambient air in the work place into the head chamber where the sensor is exposed and will result in a contaminated sample and give a false measurement.

When the desiccant head is fully extended and the sensor exposed to the sample gas, the displayed moisture reading should rise to that of the sample gas.

Take a reading when the dewpoint value on the screen has settled and is stable (Fig. 16).

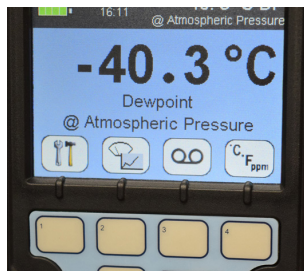

Fig. 16



Fig. 17

After a reading has been taken and sampling is complete, push the desiccant head down to isolate the sensor (Fig. 17) and switch off the instrument (Fig. 18).



Fig. 18

5 Disconnection - Follow This Procedure Exactly

DO NOT

Do not disconnect any connections whilst the *isolation valve* at the gas/air source is still open. Doing so could cause serious injury to the operator and persons near by.

DO NOT

Do not turn off the *pressure regulator* or *needle valve* at this stage. Doing so will retain pressure in the sample line.

First, TURN OFF the isolation valve fully and allow the system to fully depressurise (*Fig. 19*).



Fig. 19

When the ball in the flow indicator has fallen to “0” (zero litres per minute) as shown in *Fig. 20*, it is now safe to disconnect the sample line from the SDHmini Portable Sample System and the isolation valve.

Turn off the pressure regulator or needle valve. See section 2.1 *Fig. 3* and *Fig. 4*.



Fig. 20

6 Filter Replacement (if fitted)

WARNING

Before disassembling the filter unit (if fitted) the user must follow the de-pressurisation procedure - see section 4.

Using a 19 mm ($\frac{3}{4}$ ") spanner/wrench, carefully loosen the filter housing anti-clockwise (Fig. 21) to gain access to the filter cartridge.

Unscrew the filter cartridge retaining cap and replace the filter as necessary.

Reassembly is the reverse of the disassembly procedure. Tighten lightly only.



Fig. 21

7 Sampling Very Dry Gasses and/ or at Very Low Pressure

For very dry gasses and /or very low pressure, use the “Pig-Tail” VENT tube to stop back diffusion and contaminating the sample head/ sensor (Fig. 22).



Fig. 22

8 Cleaning the SDHmini Portable Sample System

The SDHmini Portable Sample System must only be cleaned with a soft cloth dampened with mild soapy water only.

DO NOT

Do not use solvents, silicones or abrasives to clean the system.

9 Gases to Avoid

The dewpoint sensors are suitable for many different industrial and research applications. Most gases can be checked for their moisture content with no need for the calibration to be altered when changing between different gases, as the sensor operates only with reference to the water vapour content.

There are however some gases that must be avoided as they are not compatible with the material of construction of the sensor. Ammonia (NH_3), Ozone (O_3) and Chlorine (Cl) must be avoided at all times, even in small quantities. Hydrogen Chloride (HCl) also attacks the sensors very quickly. Some less aggressive acidic gases such as Sulphur Dioxide (SO_2) can be monitored as long as the moisture content is low, generally less than 100 ppm(v). If in doubt, please ask your supplier.

Sulphur hexafluoride (SF_6) has no effect on the sensor. If the gas has been exposed to arcing however, it is possible that various acidic species will have been formed that will corrode the sensor. When testing SF_6 that may have been arced therefore, an acidity test should be carried out first. If the gas proves to be acidic then the moisture test should not be carried out.

10 Guarantee

The SDHmini Portable Sample System is supplied with a two year warranty from the date of purchase. This warranty is subject to the proper operational use of the instrument and following the information provided in the Instruction Manual. The instrument should not be repaired without prior inspection or authorisation by Shaw Moisture Meters or an authorised distributor. Any unauthorised alteration or misuse may invalidate the instrument warranty.

Note: Please retain the original equipment packaging so the SDHmini Portable Sample System can be returned to Shaw Moisture Meters or your authorised distributor if required.

11 Instrument Schematic

Front View

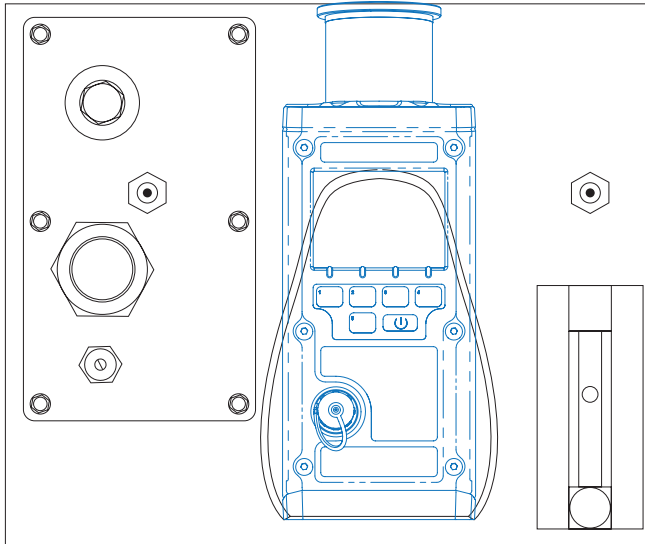

Side View

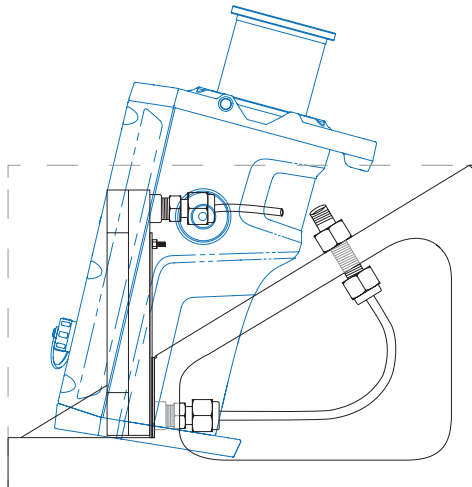

NOTE:

Instrument is for illustration purposes only and not supplied with the SDHmini Portable Sample System.

12 Dimensions



13 Specifications

- **Chassis**
304 stainless steel
- **Internal Pipework**
316 stainless steel
- **Internal Fittings**
316 stainless steel
- **Inlet Fittings**
Choice of quick connect $\frac{1}{4}$ ", $\frac{1}{8}$ " or 6 mm compression fittings
- **Flow Indicator**
Up to 10 litres per minute
- **Optional Quick Connection (inlet) Swagelok**
Maximum connected pressure 2,900PSI (200barg)
- **Filter Unit (when fitted)**
High grade stainless steel with removable housing for access to replaceable filter cartridges, 0.1 micron filter cartridge
- **Pressure Regulator (where applicable)**
High grade stainless steel
Pressure range 0 - 200barg (2,900PSI)
- **Needle Valve (where applicable)**
316 high grade stainless steel
- **Overall Dimensions**
315 mm (w) x 245 mm (d) x 270 mm (h)
- **Weight**
Without instrument - 3.75 kg (8.3 lbs)
With instrument - 5.5 kg (12 lbs)
- **Mechanical Warranty**
24 months in case of faulty workmanship and defective parts
- **Carrying Bag**
Anti-static PVC foam faux leather with rubber feet

