

JUMO GmbH & Co. KG
 Delivery address: Mackenrodtstraße 14
 36039 Fulda, Germany
 Postal address: 36035 Fulda, Germany
 Phone: +49 661 6003-0
 Fax: +49 661 6003-607
 Email: mail@jumo.net
 Internet: www.jumo.net

JUMO Instrument Co. Ltd.
 JUMO House
 Temple Bank, Riverway
 Harlow, Essex, CM20 2DY, UK
 Phone: +44 1279 63 55 33
 Fax: +44 1279 62 50 29
 Email: sales@jumo.co.uk
 Internet: www.jumo.co.uk

JUMO Process Control, Inc.
 6733 Myers Road
 East Syracuse, NY 13057, USA
 Phone: +1 315 437 5866
 Fax: +1 315 437 5860
 Email: info.us@jumo.net
 Internet: www.jumousa.com



JUMO dTRANS T06 Ex

Multifunctional Four-Wire Transmitter in Mounting Rail Case with SIL and Ex Approval

Brief description

The JUMO dTRANS T06 Ex transmitter, type 707075, according to DIN EN 61508 SIL2 is intended to be installed on a mounting rail. It is used to acquire the temperature using an RTD temperature probe or thermocouple.

In the case of an RTD temperature probe, the sensor is connected using a 2, 3, or 4-wire connection technique. The measurement input also enables the user to connect resistance sensors (resistance transmitter) and resistance/potentiometers using a 2, 3, or 4-wire connection technique, and to acquire voltage signals from -100 mV to +1100 mV, the current unit signals 0 to 20 mA and 4 to 20 mA as well as the voltage unit signal 0 to 10 V.

The output signal provided is galvanically isolated from the intrinsically safe sensor circuit (associated apparatus). Depending on the measurement input, different linearization variants (linear, temperature-linear, customer-specific, etc.) are possible.

The variants 0(4) to 20 mA and, alternatively, 0 to 10 V are available as the output signal. The functionality of the JUMO dTRANS T06 Ex, type 707075, can be expanded through the option of an RS485 interface.

A graphic display is used to visualize the measured values. The operating status is signaled optically using a 2-color LED (red/green). Smooth operation is indicated through a permanent green LED; a malfunction status is indicated through a red LED.

The sensor type, measuring range, linearization, output signal, limit values, etc. can be configured using a PC as well as the setup program. For this purpose, the device can be connected to the PC via a micro-USB port and a corresponding USB cable. Alternatively, the configuration is also possible via 4 keys.

The housing has a design width of 22.5 mm and is designed to be mounted on a DIN rail measuring 35 mm x 7.5 mm according to EN 60715. The electrical connection is established via screw terminals for conductor cross sections measuring 0.2 to 2.5 mm².

The device meets the requirements according to DIN EN 61508 SIL2. The systematic capability (SC 3) of the hardware and software corresponds to Safety Integrity Level (SIL3).

Depending on the architecture used, it is possible to achieve SIL2 or PL c for HFT=0 (single device) and SIL3 or PL d for HFT=1 (2 devices).



Type 707075/...

Block diagram

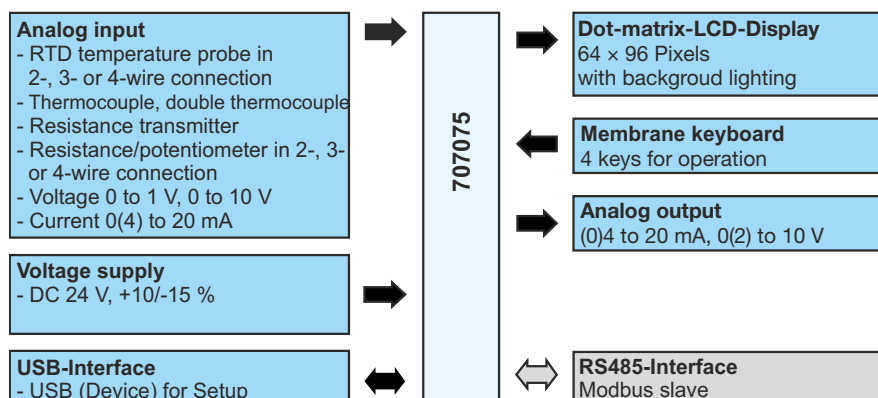

Available ex-works
 Extra code

Special features

- universal input for a variety of sensors and standard signals
- SIL2/SIL3 according to DIN EN 61508 and PL c/d according to ISO 13849
- ATEX and IECEx approval
- customer-specific linearization
- intuitive operation and configuration on the instrument or via USB interface via setup program
- RS485 interface (option)
- intelligent additional functions such as min/max drag pointer, operating hours counter and output simulation
- Connection diagram can be called up on the LCD display

Approvals/approval marks (see "Technical data")



JUMO GmbH & Co. KG
 Delivery address: Mackenrodtstraße 14
 36039 Fulda, Germany
 Postal address: 36035 Fulda, Germany
 Phone: +49 661 6003-0
 Fax: +49 661 6003-607
 Email: mail@jumo.net
 Internet: www.jumo.net

JUMO Instrument Co. Ltd.
 JUMO House
 Temple Bank, Riverway
 Harlow, Essex, CM20 2DY, UK
 Phone: +44 1279 63 55 33
 Fax: +44 1279 62 50 29
 Email: sales@jumo.co.uk
 Internet: www.jumo.co.uk

JUMO Process Control, Inc.
 6733 Myers Road
 East Syracuse, NY 13057, USA
 Phone: +1 315 437 5866
 Fax: +1 315 437 5860
 Email: info.us@jumo.net
 Internet: www.jumousa.com



Technical data

Analog input

Noise suppression, filter time, measuring value offset, and fine adjustment can be adjusted for all input variants.

RTD temperature probe

Designation	Standard	Measuring range	Measuring accuracy ^a	R ₁₀₀ / R ₀	ITS
Pt50 2/3-wire circuit 4-wire circuit	GOST 6651-2009 A.2	-200 to +850 °C -200 to +850 °C	±0.5 K ±0.3 K	1.3911	90
Pt100 2/3-wire circuit 4-wire circuit	IEC 60751:2008	-100 to +200 °C -200 to +850 °C -100 to +200 °C -200 to +850 °C	±0.2 K ±0.4 K ±0.1 K ±0.2 K	1.3851	90
Pt500, Pt1000 2/3-wire circuit 4-wire circuit	IEC 60751:2008	-100 to +200 °C -200 to +850 °C -100 to +200 °C -200 to +850 °C	±0.2 K ±0.4 K ±0.1 K ±0.2 K	1.3851	90
Ni100, Ni500, Ni1000 2/3-wire circuit 3-wire circuit	DIN 43760:1987-09	-60 to +250 °C -60 to +250 °C	±0.4 K ±0.2 K	1.618	IPTS-68
Ni100 2/3-wire circuit 3-wire circuit	GOST 6651-2009 A.5	-60 to +180 °C -60 to +180 °C	±0.4 K ±0.2 K	1.6172	90
Pt100 2/3-wire circuit 4-wire circuit	GOST 6651-2009 A.2	-100 to +200 °C -200 to +850 °C -100 to +200 °C -200 to +850 °C	±0.2 K ±0.4 K ±0.15 K ±0.25 K	1.3911	90
Cu50 2/3-wire circuit 4-wire circuit	GOST 6651-2009 A.3	-180 to +200 °C -180 to +200 °C	±0.5 K ±0.3 K	1.428	90
Cu100 2/3-wire circuit 4-wire circuit	GOST 6651-2009 A.3	-180 to +200 °C -180 to +200 °C	±0.4 K ±0.2 K	1.428	90

Ambient temperature influence	≤ ±0.005 %/K deviation from 22 °C
Measuring current	< 0.3 mA
Sensor line resistance	≤ 50 Ω per line for 3 and 4-wire circuit ≤ 100 Ω line resistance for 2-wire circuit
Lead compensation	Not required for 3-wire circuit. In 2-wire circuits, lead compensation is performed in the software by entering a fixed line resistance.
Special features	- Can also be programmed in °F - Basic sensor type can be changed with sensor factor (e.g., Pt50 to Pt100)

^a The accuracy specifications refer to the maximum measuring range.

Thermocouples

Designation	Standard	Measuring range	Measuring accuracy ^a	ITS
Fe-CuNi "L"	DIN 43710:1985-12	-200 to +900 °C	±0.1 %	IPTS-68
Fe-CuNi "J"	DIN EN 60584-1:2014	-210 to +1200 °C	±0.1 % from -100 °C	90
Cu-CuNi "U"	DIN 43710:1985-12	-200 to +600 °C	±0.1 % from -100 °C	IPTS-68
Cu-CuNi "T"	DIN EN 60584-1:2014	-200 to +400 °C	±0.1 % from -150 °C	90

JUMO GmbH & Co. KG

Delivery address: Mackenrodtstraße 14
36039 Fulda, Germany
Postal address: 36035 Fulda, Germany
Phone: +49 661 6003-0
Fax: +49 661 6003-607
Email: mail@jumo.net
Internet: www.jumo.net

JUMO Instrument Co. Ltd.

JUMO House
Temple Bank, Riverway
Harlow, Essex, CM20 2DY, UK
Phone: +44 1279 63 55 33
Fax: +44 1279 62 50 29
Email: sales@jumo.co.uk
Internet: www.jumo.co.uk

JUMO Process Control, Inc.

6733 Myers Road
East Syracuse, NY 13057, USA
Phone: +1 315 437 5866
Fax: +1 315 437 5860
Email: info.us@jumo.net
Internet: www.jumousa.com



Designation	Standard	Measuring range	Measuring accuracy ^a	ITS
NiCr-Ni "K"	DIN EN 60584-1:2014	-200 to +1300 °C	±0.1 % from -80 °C	90
NiCr-CuNi "E"	DIN EN 60584-1:2014	-200 to +1000 °C	±0.1 % from -80 °C	90
NiCrSi-NiSi "N"	DIN EN 60584-1:2014	-200 to +1300 °C	±0.1 % from -80 °C	90
Pt10Rh-Pt "S"	DIN EN 60584-1:2014	-50 to 1768 °C	±0.15 % from -60 °C	90
Pt13Rh-Pt "R"	DIN EN 60584-1:2014			
Pt30Rh-Pt6Rh "B"	DIN EN 60584-1:2014	-50 to 1820 °C	±0.15 % from 400 °C	90
W5Re-W26Re "C"	DIN EN 60584-1:2014	0 to 2315 °C	±0.15 %	90
W5Re-W20Re "A1"	GOST R 8.585-2001	0 to 2500 °C	±0.15 %	90
W3Re-W25Re "D"	ASTM E1751M-15	0 to 2315 °C	±0.25 %	90
Chromel®-COPEL® "L"	GOST R 8.585-2001	-200 to +800 °C	±0.1 % from -80 °C	90
Chromel®-Alumel® "K"	GOST R 8.585-2001	-270 to +1372 °C	±0.1 % from -80 °C	90
Platinel II	ASTM E1751M-15	0 to 1395 °C	±0.15 %	90

Ambient temperature influence	≤ ±0.005 %/K deviation from 22 °C, plus accuracy of the cold junction
Measuring range start/end	Freely programmable within the limits in increments of 0.1 K
Cold junction	Pt1000 internal, thermostat (fixed constant value), adjustable
Cold junction accuracy (internal)	±1 K
Cold junction temperature (fixed constant value)	-20 to +80 °C adjustable
Special features	Can also be programmed in °F

^a The accuracy specifications refer to the maximum measuring range.

Standard signals

Designation	Measuring range	Measuring accuracy ^a	Ambient temperature influence
Voltage freely scalable Input resistance $R_E > 500 \text{ k}\Omega$ Input resistance $R_E > 1 \text{ M}\Omega$	DC 0 to 10 V DC 0 to 1 V (mV input)	±5 mV ±0.05 %	≤ ±0.005 %/K deviation from 22 °C
Current (voltage drop ≤ 2 V), freely scalable	DC 0(4) to 20 mA	±20 µA	≤ ±0.005 %/K deviation from 22 °C

Galvanic isolation	See Chapter "Electrical data", page 4 and Chapter "Galvanic isolation", page 9
Special features	Measuring range, scaling adjustable
Limits according to recommendation of NAMUR NE 43 in case of deviation under/above measuring range	Signal type 4 to 20 mA
Measurement information M	3.8 to 20.5 mA
Failure information A for deviation below measured value/short circuit ("NAMUR Low")	≤ 3.6 mA
Failure information A for deviation above measured value/probe break ("NAMUR High")	≥ 21 mA

^a The accuracy specifications refer to the maximum measuring range.

Resistance transmitter

Designation	Measuring range	Measuring accuracy ^a	Ambient temperature influence
Resistance transmitter	≤ 400Ω	±0.4 Ω	≤ ±0.01 %/K deviation from 22 °C
Resistance transmitter	400 to 4000 Ω	±4 Ω	≤ ±0.01 %/K deviation from 22 °C
Resistance transmitter	4000 to 10000 Ω	±10 Ω	≤ ±0.01 %/K deviation from 22 °C

Connection type	3-wire circuit
Sensor line resistance	Max. 50 Ω per line
Resistance values	Freely programmable within the limits in steps of 0.1 Ω
Special features	Measuring range scaling adjustable

^a The accuracy specifications refer to the maximum measuring range.

JUMO GmbH & Co. KG
 Delivery address: Mackenrodtstraße 14
 36039 Fulda, Germany
 Postal address: 36035 Fulda, Germany
 Phone: +49 661 6003-0
 Fax: +49 661 6003-607
 Email: mail@jumo.net
 Internet: www.jumo.net

JUMO Instrument Co. Ltd.
 JUMO House
 Temple Bank, Riverway
 Harlow, Essex, CM20 2DY, UK
 Phone: +44 1279 63 55 33
 Fax: +44 1279 62 50 29
 Email: sales@jumo.co.uk
 Internet: www.jumo.co.uk

JUMO Process Control, Inc.
 6733 Myers Road
 East Syracuse, NY 13057, USA
 Phone: +1 315 437 5866
 Fax: +1 315 437 5860
 Email: info.us@jumo.net
 Internet: www.jumousa.com



Resistance/potentiometer

Designation	Measuring range	Measuring accuracy ^a	Ambient temperature influence
Sensor type resistance/potentiometer	Max. 10 kΩ	±10 Ω	≤ ±0.01 %/K deviation from 22 °C

Connection type	Resistance with 2, 3, or 4-wire circuit
Sensor line resistance	≤ 50 Ω per line for 3 and 4-wire circuit ≤ 100 Ω line resistance for 2-wire circuit
Resistance values	Freely programmable within the limits in steps of 0.1 Ω
Special features	Measuring range scaling adjustable

^a The accuracy specifications refer to the maximum measuring range.

Measuring circuit monitoring

In the event of a malfunction, the outputs take on defined (configurable) statuses.

Measuring probe	Out of range	Probe/cable break	Probe/cable short circuit
RTD temperature probe	Is detected	Is detected	Is detected
Resistance transmitter	Is detected	Is detected	Is not detected
Thermocouple (single)	Is detected	Is detected	Is not detected
Double thermocouple	Is detected	Is detected	Is detected
Voltage 0 to 10 V 0 to 1 V	Is detected Is detected	Is not detected Is not detected	Is not detected Is not detected
Current 4 to 20 mA 0 to 20 mA	Is detected Is detected	Is detected Is not detected	Is detected Is not detected

Analog output

Resolution of D/A converter >15 bit	Load resistance R _{Load}	Accuracy	Burden influence
Voltage DC 0(2) to 10 V	≥ 500 Ω	≤ ±0.05 % referring to 10 V	≤ ±15 mV
Current DC 0(4) to 20 mA	≤ 500 Ω	≤ ±0.05 % referring to 20 mA	≤ ±0.02 %/100 Ω

Display

Type, resolution	Dot-matrix LCD display with 64 × 96 pixels
Brightness setting	Contrast can be adjusted on device, backlight can be switched off via timeout

Electrical data

Voltage supply	DC 24 V, +10/-15 %
Power consumption	With voltage supply 24 V: max. 3 W
Inputs and outputs Conductor cross section	Max. 2.5 mm ² , wire or strand with ferrule
Electrical safety	According to DIN EN 61010-1 Overvoltage category III, pollution degree 2
Electromagnetic compatibility Interference emission Interference immunity	According to DIN EN 61326-1 Class A - For industrial applications only - Industrial requirements
Sampling rate	500 ms
Input filter	Digital filter, 2nd order; filter time constant can be adjusted from 0 to 100 s

JUMO GmbH & Co. KG
 Delivery address: Mackenrodtstraße 14
 36039 Fulda, Germany
 Postal address: 36035 Fulda, Germany
 Phone: +49 661 6003-0
 Fax: +49 661 6003-607
 Email: mail@jumo.net
 Internet: www.jumo.net

JUMO Instrument Co. Ltd.
 JUMO House
 Temple Bank, Riverway
 Harlow, Essex, CM20 2DY, UK
 Phone: +44 1279 63 55 33
 Fax: +44 1279 62 50 29
 Email: sales@jumo.co.uk
 Internet: www.jumo.co.uk

JUMO Process Control, Inc.
 6733 Myers Road
 East Syracuse, NY 13057, USA
 Phone: +1 315 437 5866
 Fax: +1 315 437 5860
 Email: info.us@jumo.net
 Internet: www.jumousa.com



Environmental influences

Operating temperature range	-10 to +70 °C,
Storage temperature range	-20 to +80 °C
Resistance to climatic conditions	≤ 85% relative humidity, annual average, no condensation

Housing

Site altitude	Maximum 2000 m above sea level
Housing type, material	Plastic housing, polycarbonate (use indoors only)
Flammability class	UL94 V0
Electrical connection	Via pluggable screw terminals
Electrical wiring	In line with the operating conditions, the temperature may exceed 60 °C at the terminals. As a result, the insulation of the cables connected at the terminals may be damaged. The affected cables must be heat-resistant up to at least 80 °C.
Mounting on	Mounting rail 35 mm × 7.5 mm according to DIN IEC 60715
Close mounting	Permitted
Installation position	Vertical
Protection type	IP20 according to DIN EN 60529
Weight with screw terminals	Approx. 200 g

Approvals/approval marks

Approval mark	Test facility	Certificate/certification number	Inspection basis	Valid for
SIL2	TÜV Nord (German Technical Inspection Agency)	SEBS-A.20140509.0933409	EN 61508 1-7	All modules
PL c			EN ISO 13849	
ATEX "i"		TÜV 19 ATEX 244073 X	Directive 2014/34/EU EN 60079-0 EN 60079-11	
ATEX "h"			Directive 2014/34/EU EN 80079-36 EN 80079-37	
ATEX safety device pursuant to "e" and "t"			IEC 60079-0, IEC 60079-11 ISO 80079-36, ISO 80079-37	
IECEX "i"		IECEX TUN 19.0005X	IEC 60079-0 IEC 60079-11	
IECEX "h"	ISO 80079-36 ISO 80079-37			

Connection possibilities for probes

JUMO probes according to data sheet 902820 can be connected. These probes have been type-tested for use in Ex areas. The values are described in the safety manual for RTD temperature probes and thermocouples for connection to the JUMO dTRANS T06 type 707075. The probes must also have been qualified for use in the Ex area.

Electrical data for the probe input

The 707075 has the following maximum output data at the intrinsically safe input:				
$U_o = 6.0 \text{ V}$	$I_o = 13.3 \text{ mA}$	$P_o = 19.9 \text{ mW}$	$C_o = 39.32 \text{ }\mu\text{F}$	$L_o = 0.2 \text{ H}$

Explanation of device identification markings

The device has approval according to ATEX and IECEx and can therefore also be used for measurements in Ex areas. However, the device itself has to be installed outside the Ex area. The inputs are intrinsically safe [Ex ia] so that relevant probes can be connected directly.

JUMO GmbH & Co. KG

Delivery address: Mackenrodtstraße 14
36039 Fulda, Germany
Postal address: 36035 Fulda, Germany
Phone: +49 661 6003-0
Fax: +49 661 6003-607
Email: mail@jumo.net
Internet: www.jumo.net

JUMO Instrument Co. Ltd.

JUMO House
Temple Bank, Riverway
Harlow, Essex, CM20 2DY, UK
Phone: +44 1279 63 55 33
Fax: +44 1279 62 50 29
Email: sales@jumo.co.uk
Internet: www.jumo.co.uk

JUMO Process Control, Inc.

6733 Myers Road
East Syracuse, NY 13057, USA
Phone: +1 315 437 5866
Fax: +1 315 437 5860
Email: info.us@jumo.net
Internet: www.jumousa.com



	II (1) G [Ex ia Ga] IIC
	II (1) D [Ex ia Da] IIIC
	II (2) G [Ex eb Gb] IIC
	II (1) D [Ex ta Da] IIIC
	II (2) D [Ex tb Db] IIIC
	II (1) G [Ex h Ga] IIC
	II (1) D [Ex h Da] IIIC

	[Ex ia Ga] IIC
	[Ex ia Da] IIIC
	[Ex h Ga] IIC
	[Ex h Da] IIIC

Barriers are no longer required.

The device is also certified according to DIN EN 50495 as an ignition source monitor as specified in the ATEX directive and can be used to monitor potentially explosive atmospheres containing gas or dust.

Identification marking for ATEX ignition protection type "i"

	II (1) G [Ex ia Ga] IIC
	II (1) D [Ex ia Da] IIIC
	Standard designation according to EN 60079-0 Explosion group II C gases, low ignition energy such as hydrogen III C conductive dusts
	Equipment Protection Level: Ga (gases) for category 1, zone 0 for gas Da (dust) for category 1, zone 20 for dust
	Designation according to standard series EN 60079 for electrical devices ia: related equipment according to ignition protection „i“ intrinsically safe according to EN 60079-11 „ia“ (2-failsafe) for category 1
	Standard designation
	Category according to ATEX directive 2014/34/EU G: gas explosion protection; D: dust explosion protection
	Related equipment for intrinsic safety according to EN 60079-11 for category 1 Applications for ignition protection type intrinsic safety „ia“
	Guidelines designation for device group II (non-firedamp endangered mine workings)
	Designation explosionproof according to ATEX directive 2014/34/EU



Identification marking for ATEX ignition protection type "e" and "t"

	II	(2)	G	[Ex eb Gb]	IIC
	II	(1)	D	[Ex ta Da]	IIIC
	II	(2)	D	[Ex tb Db]	IIIC

Standard designation according to EN 60079-0
 Explosion group II C gases, low ignition energy such as hydrogen
 III C conductive dusts

Equipment Protection Level:
 Gb: for use in zone 1 or 2 for gases
 Da: for use in zone 20, 21 or 22 for dust
 Db: for use in zone 21 or 22 for dust

Designation according to series of standards EN 50495 ¹⁾
 "eb" increased safety for category 2, b: zone 1 or 2 for gas
 "ta" protection with housing for category 1, a: zone 20, 21 or 22 for dust
 "tb" protection with housing for category 2, b: zone 21 or 22 for dust
 Designation according to series of standards EN 60079 for electrical devices
 ignition protection "e" increased safety according to EN 60079-7
 ignition protection "t" dust explosion protection with housing acc. to EN 60079-31

Standard designation

Category according to ATEX directive 2014/34/EU
 G: gas explosion protection
 D: dust explosion protection

Safety devices according to EN 50495
 - for category 2 applications for ignition protection type increased safety "e" according to EN 60079-7
 - for category 1 applications for ignition protection type with housing „ta" according to EN 60079-31
 - for category 2 applications for ignition protection type with housing „tb" according to EN 60079-31

Guidelines designation for device group II (non-firedamp endangered mine workings)

Designation explosionproof according to ATEX directive 2014/34/EU

1.) The monitored electrical equipment is not a potential ignition source in normal operation

Identification marking for ATEX ignition protection type "h"

	II	(1)	G	[Ex h Ga]	IIC
	II	(1)	D	[Ex h Da]	IIIC

Standard designation according to EN 60079-0
 Explosion group II C gases, low ignition energy such as hydrogen
 III C conductive dusts

Equipment Protection Level:
 Ga (gases) for category 1, zone 0 for gas
 Da (dust) for category 1, zone 20 for dust

Designation according to standard series EN 80079-37
 for non-electrical devices
 "h": related equipment according to ignition protection "h" for category 1

Standard designation

Category according to ATEX directive 2014/34/EU
 G: gas explosion protection; D: dust explosion protection

Related equipment for intrinsic safety according to EN 60079-11 for category 1
 Applications for ignition protection type intrinsic safety „ia"

Guidelines designation for device group II (non-firedamp endangered mine workings)

Designation explosionproof according to ATEX directive 2014/34/EU



Identification marking for IECEx ignition protection type "ia"

 [Ex ia Ga] IIC Associated apparatus which is set up outside the gas atmosphere but the intrinsically safe electrical circuit "ia" (protection through 2 protective measures) leads into zone 0.
 [Ex ia Da] IIIC Associated apparatus which is set up outside the dust atmosphere but the intrinsically safe electrical circuit "ia" (protection through 2 protective measures) leads into zone 20.

Standard designation according to IEC 60079-0 Explosion group II C gases, low ignition energy such as hydrogen III C conductive dusts
Equipment Protection Level: Ga (gases) for category 1 Da (dust) for category 1
Standard designation according to standard series IEC 60079 for electrical devices ia: related equipment according to ignition protection „i“ intrinsically safe according IEC 60079-11, „ia“ (2-failsafe) for category 1

Identification marking for IECEx ignition protection type "h"

 [Ex h Ga] IIC Associated apparatus which is set up outside the gas atmosphere
 [Ex h Da] IIIC Associated apparatus which is set up outside the dust atmosphere

Standard designation according to IEC 60079-0 Explosion group II C gases, low ignition energy such as hydrogen III C conductive dusts
Equipment Protection Level: Ga (gases) for category 1, zone 0 for gas Da (dust) for category 1, zone 20 for dust
Designation according to standard series EN 80079-37 for non-electrical devices "h": related equipment according to ignition protection "h" for category 1

Display and control elements

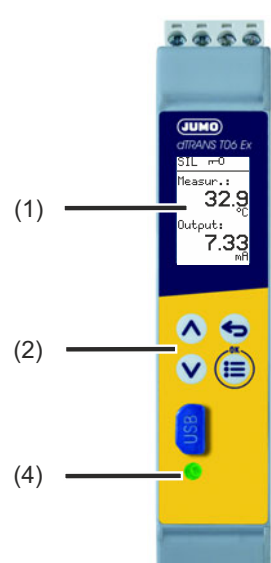
Legend	Comment	
(1)	Black and white dot-matrix LCD display with backlight, 64 x 96 pixels	
(2)	4 keys for operating the device	
(4)	LED	



Galvanic isolation

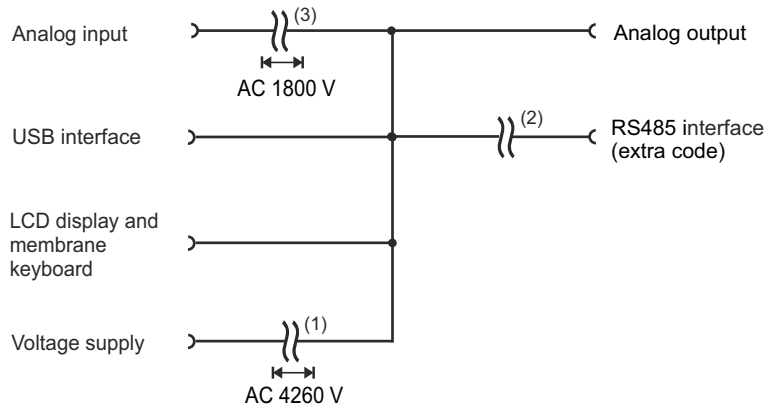

- (1) The voltage specifications correspond to the alternating test voltages (effective values) according to EN 61010-1:2011-07 for type testing.
- (2) Functional galvanic isolation for the connection of SELV or PELV circuits.
- (3) The voltage specification corresponds to the alternating test voltage (effective value) according to DIN EN 61010-1:2011-07 for type testing to connect SELV or PELV electrical circuits [secondary electrical circuits which are derived from supply current circuits with overvoltage category III (>150 V ≤ 300 V)].

Connection elements



(13, 14) Voltage supply
 (31, 32, 33, 34) RS485 interface

(41, 42, 43, 44) Analog output
 (51, 52, 53, 54) Analog input



Connection diagram

The connection diagram in the data sheet provides preliminary information about the connection options. For the electrical connection, only use the installation instructions or the operating manual. The knowledge and the correct technical execution of the safety information and warnings contained in these documents are mandatory for installation, electrical connection, startup, and for safety during operation.

Analog input

Connection	Screw terminals	Symbol and terminal designation
Thermocouple	(51, 52)	
Double thermocouple	(51, 52, 53, 54)	
RTD temperature probe or resistance/potentiometer 2-wire connection	(51, 52, 53, 54)	
RTD temperature probe or resistance/potentiometer 3-wire connection	(51, 52, 53, 54)	
RTD temperature probe or resistance/potentiometer 4-wire connection	(51, 52, 53, 54)	
Voltage DC 0 to 10 V	(51, 52, 53, 54)	
Voltage DC 0 to 1 V (mV input)	(51, 52, 53, 54)	
Current DC 0(4) to 20 mA	(51, 52, 53, 54)	
Resistance transmitter A = Start E = End S = Slider	(51, 52, 53, 54)	

Analog output

Connection	Screw terminals	Symbol and terminal designation
Current output DC 0(4) to 20 mA (configurable)	(42, 43)	
Voltage output DC 0(2) to 10 V (configurable)	(41, 43)	

JUMO GmbH & Co. KG
 Delivery address: Mackenrodtstraße 14
 36039 Fulda, Germany
 Postal address: 36035 Fulda, Germany
 Phone: +49 661 6003-0
 Fax: +49 661 6003-607
 Email: mail@jumo.net
 Internet: www.jumo.net

JUMO Instrument Co. Ltd.
 JUMO House
 Temple Bank, Riverway
 Harlow, Essex, CM20 2DY, UK
 Phone: +44 1279 63 55 33
 Fax: +44 1279 62 50 29
 Email: sales@jumo.co.uk
 Internet: www.jumo.co.uk

JUMO Process Control, Inc.
 6733 Myers Road
 East Syracuse, NY 13057, USA
 Phone: +1 315 437 5866
 Fax: +1 315 437 5860
 Email: info.us@jumo.net
 Internet: www.jumousa.com



Voltage supply (according to nameplate)

DC 24 V

Connection	Screw terminals	Symbol and terminal designation
	(L+) (L-)	

Interfaces

Interfaces USB device, RS485

Connection	Screw terminals	Symbol and terminal designation						
USB interface (device) Micro-B connector, standard (5-pole)	(3)							
Serial interface RS485	(31, 32, 33, 34)	<table style="display: inline-table; vertical-align: top; margin-left: 20px;"> <tr> <td>31 TxD+/RxD+</td> <td>Transmission/received data +</td> </tr> <tr> <td>32 GND</td> <td>Ground</td> </tr> <tr> <td>33 TxD-/RxD-</td> <td>Transmission/received data -</td> </tr> </table>	31 TxD+/RxD+	Transmission/received data +	32 GND	Ground	33 TxD-/RxD-	Transmission/received data -
31 TxD+/RxD+	Transmission/received data +							
32 GND	Ground							
33 TxD-/RxD-	Transmission/received data -							

Dimensions

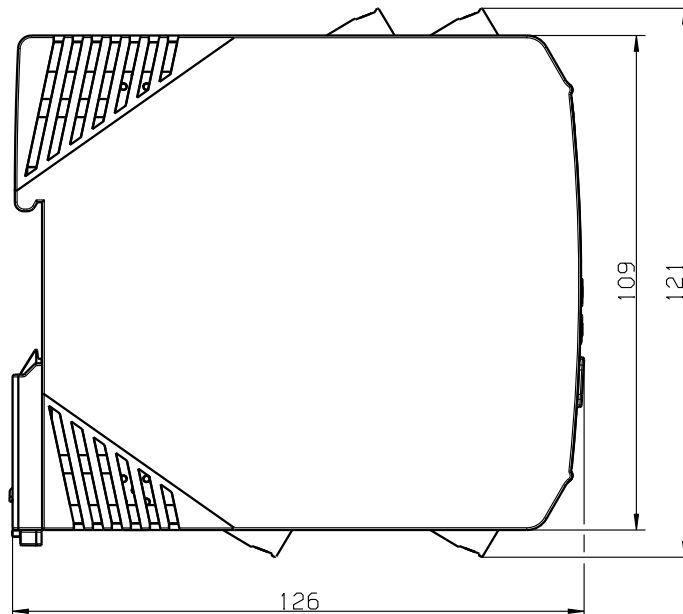
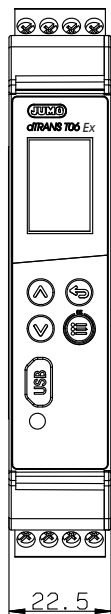

JUMO GmbH & Co. KG

Delivery address: Mackenrodtstraße 14
36039 Fulda, Germany
Postal address: 36035 Fulda, Germany
Phone: +49 661 6003-0
Fax: +49 661 6003-607
Email: mail@jumo.net
Internet: www.jumo.net

JUMO Instrument Co. Ltd.

JUMO House
Temple Bank, Riverway
Harlow, Essex, CM20 2DY, UK
Phone: +44 1279 63 55 33
Fax: +44 1279 62 50 29
Email: sales@jumo.co.uk
Internet: www.jumo.co.uk

JUMO Process Control, Inc.

6733 Myers Road
East Syracuse, NY 13057, USA
Phone: +1 315 437 5866
Fax: +1 315 437 5860
Email: info.us@jumo.net
Internet: www.jumousa.com



Order details

(1) Basic type	
707075	dTRANS T06 Ex with SIL and PL approval
(2) Version	
8	Standard with default settings
9	Customer-specific configuration (specifications in plain text)
(3) Voltage supply	
29	DC 24 V +10/-15 % SELV or PELV
(4) Extra codes	
000	None
053	RS485 Modbus RTU

(1) / (2) - (3) - (4)

Order code / - - , ...

Order example 707075 / 8 - 29 - 053

Scope of delivery

- JUMO dTRANS T06 Ex in the ordered version
- Operating manual

General accessories

Item	Part no.
Setup program, multilingual	00668006
USB cable A-connector to Micro-B connector, length 3 m, for type 707071	00616250
Screw-on end clamp for mounting rail	00528648

OneTemp[®] Pty Ltd
MEASURE | CONTROL | RECORD
www.onetemp.com.au
1300 768 887