

# JUMO dTRANS T06 Ex

Multifunctional Four-Wire Transmitter  
in Mounting Rail Case  
with SIL and Ex Approval



**Operating manual**  
(English translation of the  
original German manual)

70707500T90Z001K000

**JUMO**

V1.00/EN/00690368/2020-03-31

# Operating overview

Normal display (12s after switch-on or Time-out)

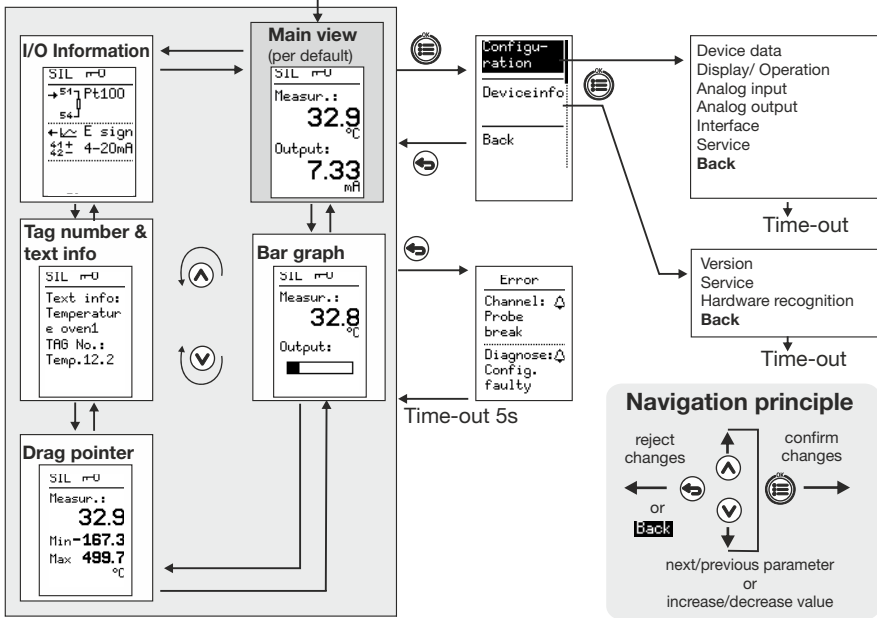

---

	<b>Operating overview</b> .....	<b>2</b>
<b>1</b>	<b>Brief description</b> .....	<b>10</b>
1.1	Safety information .....	11
<b>2</b>	<b>Identifying the device version</b> .....	<b>12</b>
2.1	Scope of delivery .....	13
2.2	Accessories .....	14
2.3	Device software version, fabrication number .....	14
2.4	Service addresses .....	14
<b>3</b>	<b>Mounting</b> .....	<b>16</b>
3.1	Dimensions .....	16
3.2	Mounting site, DIN-rail mounting .....	17
3.3	Close mounting .....	17
3.4	Dismounting .....	18
3.5	Galvanic isolation .....	19
3.6	Use of the USB interface .....	19
<b>4</b>	<b>Electrical connection</b> .....	<b>20</b>
4.1	Installation notes .....	20
4.2	Connection diagram .....	21
4.2.1	Analog input (part of the safety channel) .....	22
4.2.2	Analog output (part of the safety channel) .....	24
4.2.3	Voltage supply (DC 24 V) .....	24
4.3	Checking the wiring of the intrinsically safe electrical circuit .....	25
4.2.4	Extra codes .....	25

---

<b>5</b>	<b>Starting operation of the device</b>	<b>26</b>
5.1	Display and control elements	26
5.2	Setting the display after device is switched on	26
5.3	SIL operation	28
5.4	Signal flow	29
<b>6</b>	<b>Safety manual</b>	<b>32</b>
6.1	Brief description, intended use	32
6.2	Validity of the safety manual	33
6.3	Special operating statuses	33
6.3.1	Behavior after a power failure	33
6.3.2	During setup data transfer	33
6.3.3	After alteration of the configuration level (at the device or through setup)	34
6.3.4	Issue of an error signal (safe state)	34
6.4	Relevant standards	34
6.5	Connection possibilities of the sensors	35
6.5.1	Terms and abbreviations according to DIN EN 61508 and DIN EN 61511	35
6.5.2	Safety-relevant parameters	38
6.5.3	Failure rates and SFF for 707075/X-29-XXX (DC 24 V)	38
6.5.4	Calculation of PFD avg	39
6.6	Determining the safety integrity level (SIL)	41
6.6.1	Safety integrity of the hardware	42
6.6.2	Safety-relevant system properties	43
6.6.3	Redundant use of the system	44
6.7	Determining the performance level (PL)	45
6.7.1	Terms and abbreviations according to standards series DIN EN ISO 13849	46
6.7.2	Calculations of the DIN EN ISO 13849-1 performance level – 707075/X - 29/XXX (DC 24 V)	47
6.7.3	Risk reduction through the control system	48

6.8	Other applicable device documentation .....	49
6.9	Behavior during operation and in case of malfunction .....	49
6.10	Regular tests .....	50
6.10.1	Proof test A .....	50
6.10.2	Proof test B .....	50
6.10.3	Proof test C .....	54
6.10.4	Recommended tests for temperature probes .....	55
<b>7</b>	<b>ATEX</b> .....	<b>56</b>
7.1	Ignition protection type "i" .....	56
7.1.1	Associated, intrinsically safe electrical apparatus according to EN 60079-11 .....	56
7.1.2	Intended use .....	57
7.1.3	Installation regulations .....	58
7.2	Identification marking for ATEX ignition protection type "i" .....	59
7.3	Safety device according to EN 50495 according to ATEX ignition protection type "e" and "t" .....	60
7.3.1	Safety device according to EN 50495 .....	61
7.4	Identification marking for ATEX ignition protection type "h" .....	62
7.5	Ignition source monitoring "h" according to EN 80079-37 .....	62
7.5.1	Ignition source monitoring "b" .....	62
7.5.2	Types of ignition protection system .....	63
7.5.3	Using the types of ignition protection system .....	63
7.5.4	Identification marking .....	63
<b>8</b>	<b>IECEx</b> .....	<b>64</b>
8.1	Intended use .....	64
8.2	Identification marking for IECEx ignition protection type "ia": .....	64
8.3	Identification marking for IECEx ignition protection type "h" .....	65

---

8.4	Excerpt of important device data . . . . .	66
<b>9</b>	<b>Configuration . . . . .</b>	<b>68</b>
9.1	Overview . . . . .	68
9.2	Device data . . . . .	69
9.2.1	Language. . . . .	69
9.2.2	Language prompt after "power on". . . . .	69
9.2.3	Unit . . . . .	69
9.3	Display/operation . . . . .	70
9.3.1	Normal display. . . . .	70
9.3.2	Decimal place . . . . .	70
9.3.3	Contrast. . . . .	70
9.3.4	Lighting . . . . .	71
9.3.5	Lighting timeout. . . . .	71
9.3.6	Operation timeout . . . . .	71
9.3.7	Code . . . . .	71
9.4	Analog input . . . . .	72
9.4.1	Sensor type . . . . .	72
9.4.2	Linearization . . . . .	73
9.4.3	Temperature difference . . . . .	74
9.4.4	Temperature compens. . . . .	74
9.4.5	TC fixed value . . . . .	74
9.4.6	Resistance measuring range . . . . .	74
9.4.7	Line resistance . . . . .	74
9.4.8	Sensor factor. . . . .	74
9.4.9	Resistance Rx . . . . .	75
9.4.10	Line resistance RL. . . . .	75

9.4.11	Resistance R0 . . . . .	75
9.4.12	Resistance Ra, . . . . .	76
9.4.13	Resistance Rs . . . . .	76
9.4.14	Resistance Re . . . . .	76
9.4.15	Scaling start . . . . .	76
9.4.16	Scaling end . . . . .	76
9.4.17	Offset . . . . .	76
9.4.18	Fine adjust. actual start . . . . .	77
9.4.19	Fine adjust. actual end value . . . . .	77
9.4.20	Fine adjust. target start . . . . .	77
9.4.21	Fine adjust. target end value . . . . .	77
9.4.22	Noise suppression . . . . .	77
9.4.23	Filter time constant . . . . .	77
9.5	Analog output . . . . .	78
9.5.1	Signal type . . . . .	78
9.5.2	Output range start . . . . .	78
9.5.3	Output range end . . . . .	78
9.5.4	Scaling start . . . . .	78
9.5.5	Scaling end . . . . .	78
9.5.6	Output reversion . . . . .	78
9.5.7	Error signal . . . . .	79
9.5.8	Output simulation . . . . .	79
9.5.9	Simulation value . . . . .	79
9.5.10	Behavior when leaving the scaling range . . . . .	80
9.6	RS485 interface . . . . .	81
9.6.1	Baud rate . . . . .	81
9.6.2	Data format . . . . .	81

---

9.6.3	Device address . . . . .	.81
9.7	Service . . . . .	.81
9.7.1	Minimum measured value . . . . .	.81
9.7.2	Maximum measured value . . . . .	.81
9.7.3	Min. measured value reset . . . . .	.81
9.7.4	Max. measured value reset . . . . .	.81
<b>10</b>	<b>Device info . . . . .</b>	<b>82</b>
10.1	Version . . . . .	.82
10.2	Service . . . . .	.83
10.2.1	Total operation time . . . . .	.83
10.2.2	Operation time since last configuration . . . . .	.83
10.3	Hardware identification . . . . .	.83
<b>11</b>	<b>Technical data . . . . .</b>	<b>84</b>
11.1	Analog input . . . . .	.84
11.1.1	RTD temperature probe . . . . .	.84
11.1.2	Thermocouples . . . . .	.86
11.1.3	Standard signals . . . . .	.87
11.1.4	Resistance transmitter . . . . .	.88
11.1.5	Resistance/potentiometer . . . . .	.89
11.2	Measuring circuit monitoring . . . . .	.89
11.3	Test voltages . . . . .	.90
11.4	Electrical safety . . . . .	.90
11.5	Analog output . . . . .	.90
11.6	Display . . . . .	.90
11.7	Electrical data . . . . .	.91



---

11.8	Environmental influences . . . . .	91
11.9	Housing . . . . .	91
11.10	Approvals/approval marks . . . . .	93
<b>12</b>	<b>Setup program . . . . .</b>	<b>94</b>
12.1	Minimum hardware and software requirements: . . . . .	94
12.2	Displaying the device software version . . . . .	94
12.3	Forgotten the code? . . . . .	95
12.4	Customer-specific linearization . . . . .	95
12.5	Resetting the drag indicator. . . . .	96
12.6	Switching on/switching off the SIL extra code . . . . .	97
12.7	Checking safety-relevant system properties . . . . .	97
<b>13</b>	<b>Error messages . . . . .</b>	<b>98</b>
13.1	Display types . . . . .	98
13.2	Safety channel . . . . .	99
13.3	Diagnostics channel. . . . .	101
13.4	Measured value recording . . . . .	103
<b>14</b>	<b>What to do, if ... . . . .</b>	<b>104</b>
<b>15</b>	<b>Certificates . . . . .</b>	<b>106</b>
15.1	EU-Conformity . . . . .	107
15.2	SIL and PL . . . . .	111
15.3	ATEX. . . . .	112
15.4	IECEX . . . . .	115
15.5	China RoHS . . . . .	120

---

## **1 Brief description**

The JUMO dTRANS T06 Ex transmitter, type 707075, according to DIN EN 61508 SIL2 is intended to be installed on a mounting rail. It is used to acquire the temperature using an RTD temperature probe or thermocouple.

In the case of an RTD temperature probe, the sensor is connected using a 2, 3, or 4-wire connection technique. The measurement input also enables the user to connect resistance sensors (resistance transmitter) and resistance/potentiometers using a 2, 3, or

4-wire connection technique, and to acquire voltage signals from -100 mV to +1100 mV, the current unit signals 0 to 20 mA and 4 to 20 mA as well as the voltage unit signal 0 to 10 V.

The output signal provided is galvanically isolated from the intrinsically safe sensor circuit (associated apparatus). Depending on the measurement input, different linearization variants (linear, temperature-linear, customer-specific, etc.) are possible.

The variants 0(4) to 20 mA and, alternatively, 0 to 10 V are available as the output signal. The functionality of the JUMO dTRANS T06 Ex, type 707075, can be expanded through the option of an RS485 interface.

A graphic display is used to visualize the measured values. The operating status is indicated visually using a 2-color LED (red/green). Smooth operation is indicated through a permanent green LED; a malfunction status is indicated through a red LED.

The sensor type, measuring range, linearization, output signal, limit values, etc. can be configured using a PC as well as the setup program. For this purpose, the device can be connected to the PC via a micro-USB port and a corresponding USB cable. Alternatively, configuration is also possible via four keys.





The housing has a design width of 22.5 mm and is designed to be mounted on a DIN rail measuring 35 mm x 7.5 mm according to EN 60715. The electrical connection is established via screw terminals for conductor cross sections measuring 0.2 to 2.5 mm<sup>2</sup>.

The device meets the requirements according to DIN EN 61508 SIL2. The systematic capability (SC 3) of the hardware and software corresponds to Safety Integrity Level (SIL3).

Depending on the architecture used, it is possible to achieve SIL2 or PL c for HFT=0 (single device) and SIL3 or PL d for HFT=1 (2 devices).

The use of type 707075/X... enables early and reliable detection of risks which could potentially result in personal injuries, environmental damage, or destruction of the production plant and production materials.

## 1.1 Safety information

Symbol	Meaning	Explanation
	Note	This symbol refers to important information about the product, its handling, or additional benefits.
	Danger	This symbol indicates that personal injury from electrocution may occur if the appropriate precautionary measures are not taken.
	Caution	This symbol in connection with the signal word indicates that <b>material damage</b> or <b>data loss</b> will occur if the respective precautionary measures are not taken.
	Warning	This symbol in connection with the signal word indicates that <b>personal injury</b> may occur if the respective precautionary measures are not taken.
	Read	This symbol, which is attached to the device, indicates that the associated device documentation must be followed. This is necessary in order to recognize the nature of the potential danger and take the necessary measures to prevent it. Manipulations not described in the operating manual or expressly forbidden will jeopardize your warranty rights.
⇒	Reference	This symbol refers to further information in other manuals, chapters, or sections.
abc <sup>1</sup>	Footnote	Remarks at the end of a page that <b>refer to</b> specific text passages and are marked with a number placed in superscript.
*	Action instruction	The steps (marked with an asterisk) must be carried out one after another in the reading order.

## 2 Identifying the device version

The nameplates are affixed to the side of the device.

**JUMO GmbH & Co. KG** 36039 Fulda  
Germany  
www.jumo.net

Typ: 707075/8-29/000

SW: 348.01.01/349.01.01

0...100 °C Pt100 dl

4...20 mA

DC 24V +10/-15 %, max. 3 W

**PL** **SIL**

**CE**

F-Nr.: 0000000001001010000 TN: 00694863

Software version

SIL+PL approval

**Voltage supply DC 24 V:**

(The device may only be connected to SELV or PELV electrical circuits)

**JUMO GmbH & Co. KG** 36039 Fulda, Germany  
www.jumo.net

**JUMO dTRANS T06 Ex**

**Ex**

IECEx

II (1) G [Ex ia Ga] IIC  
II (1) D [Ex ia Da] IIIC  
II (2) G [Ex eb Gb] IIC  
II (1) D [Ex ta Da] IIIC  
II (2) D [Ex tb Db] IIIC  
II (1) G [Ex h Ga] IIC  
II (1) D [Ex h Da] IIIC  
TUV 19 ATEX 244073 X  
[Ex ia Ga] IIC  
[Ex ia Da] IIIC  
[Ex h Ga] IIC  
[Ex h Da] IIIC  
IECEx TUN 19.0005X

Klemmen / Terminals / Borne: 51, 52, 53, 54

U<sub>0</sub> = 6,0 V C<sub>0</sub> = 39,32 µF\* \*: see certificate  
I<sub>0</sub> = 13,3 mA L<sub>0</sub> = 0,2 H\*  
P<sub>0</sub> = 19,9 mW -10°C ≤ T<sub>a</sub> ≤ +70°C

**Ex identification marking**



### Caution

The voltage supply that is connected must correspond to the voltage specified on the nameplate!

<b>(1)</b>	<b>Basic type</b>
707075	dTRANS T06 Ex with SIL and PL approval
<b>(2)</b>	<b>Version</b>
8	Standard with default settings
9	Customer-specific configuration (specifications in plain text)
<b>(3)</b>	<b>Voltage supply</b>
29	DC 24 V +10/-15 % (the device may only be connected to SELV or PELV electrical circuits)
<b>(4)</b>	<b>Extra codes</b>
000	None
053	RS485 interface Modbus-RTU

**(1) / (2) - (3) / (4)**

**Order code**

/  -  /

**Order example**

707075 / 8 - 29 / 053

## 2.1 Scope of delivery

- Type 707075 in the ordered version
  - Operating manual
- ⇒ The interface description can be downloaded from [www.jumo.de](http://www.jumo.de).

## 2.2 Accessories

Item	Part no.
Setup program on CD-ROM, multilingual	00668006
USB cable A-connector to Micro-B connector, length 3 m, for type 707075	00616250
Screw-on end clamp for mounting rail	00528648

## 2.3 Device software version, fabrication number

⇒ Chapter 10.1 "Version"

## 2.4 Service addresses

⇒ See back cover



### Read

This operating manual is the translation of the **German manual**.  
It is valid for the following hardware and software version(s):

Channel: 348.02.01

Diagnostics: 349.02.01



### Note

Keep the operating manual in a place that is accessible to all users at all times.  
Use the device software version to check that the documentation matches your device.



### **Caution**

All the necessary settings are described in the operating manual.

Manipulations that are not described in the operating manual or that are expressly forbidden will jeopardize your warranty rights and may render the assured function inoperative!

Any interference with the inside of the device is prohibited!

Repairs may only be performed by JUMO in the company's headquarters in Fulda.

If you have any problems, please contact the nearest branch office or the head office.

### 3 Mounting

#### 3.1 Dimensions

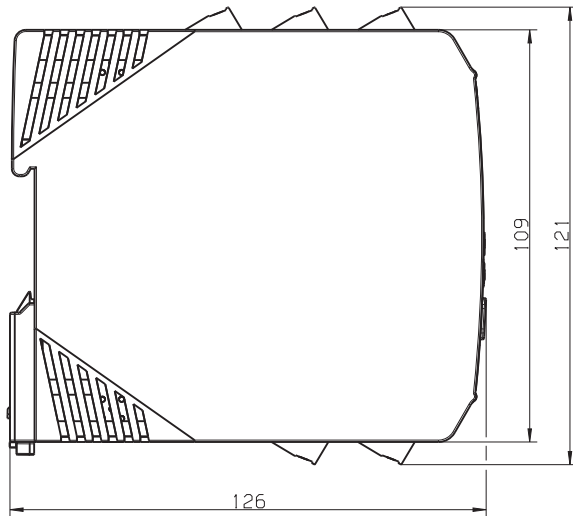



## 3.2 Mounting site, DIN-rail mounting



The device is **not** suitable for installation in potentially explosive areas. The device is clipped to a 35-mm DIN rail (DIN EN 60715) from the front and locked into place by pressing downward.

- The ambient conditions at the mounting site must meet the requirements specified in the technical data.
  - ⇒ Chapter 11 "Technical data"
- Ensure vibration-free installation to prevent the screw connections from working loose!
- The atmosphere must be free from aggressive media (e.g., strong acids and lyes), as well as free from dust, flour, or other suspended solids to prevent blocking of the cooling slots!



## 3.3 Close mounting

- Maintain the minimum distance of 20 mm above and below.
  1. So that the release slot at the bottom can still be accessed with a slotted screwdriver.
  2. So that when dismounting, the device can be swiveled upward and removed from the DIN rail.
- Several devices can be mounted right next to one another without a minimum distance.

### 3.4 Dismounting

- Place screwdriver in release catch at bottom and press upward (1).
- Remove housing upward (2).

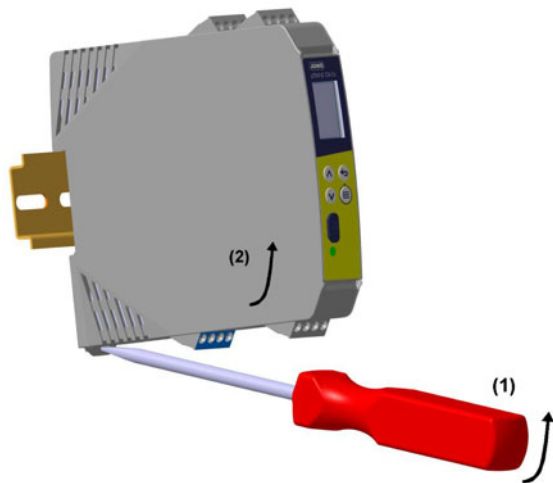

### 3.5 Galvanic isolation

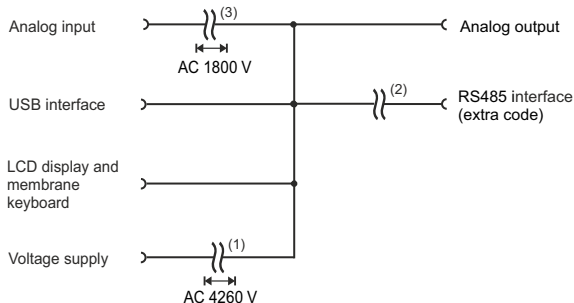

(1) The voltage specifications correspond to the alternating test voltages (effective values) according to EN 61010-1:2011-07 for type testing.

(2) Functional galvanic isolation for the connection of SELV or PELV circuits.

(3) The voltage specification corresponds to the alternating test voltage (effective value) according to DIN EN 61010-1:2011-07 for type testing to connect SELV or PELV electrical circuits [secondary electrical circuits which are derived from supply current circuits with overvoltage category III ( $>150\text{ V} \leq 300\text{ V}$ )].

### 3.6 Use of the USB interface

- The USB interface is only designed for service use over a limited period, since the device switches the output signal to safe state when in SIL operation during data transmission with the setup program!
- The RS485 interface is suitable for unlimited operation of the interface in a fixed installation.

## 4 Electrical connection

### 4.1 Installation notes

- Check to see if the device is installed in a manner appropriate to the application (temperature measurement) and that it is operated within the admissible plant parameters.
- The device is intended to be installed in control cabinets, machines, or plants. Ensure that the customer's fuse protection does not exceed 20 A.
- Disconnect the device from the mains voltage on all poles prior to starting service or repair work.
- All incoming and outgoing lines without a connection to the power supply network must be laid with shielded and twisted lines. The shield must be grounded on the device side.
- Do not lay the input and output cables close to components or lines through which current is flowing.
- Do not connect any additional loads to the screw terminals for the voltage supply of the device.
- Both the choice of cable material for the installation as well as the electrical connection of the device must conform to the local requirements of VDE 0100 "Regulations on the Installation of Power Circuits with Nominal Voltages below 1000 V" or the appropriate regulations for the country.
- The electromagnetic compatibility conforms to the standards and regulations cited in the technical data.  
⇒ Chapter 11 "Technical data"
- As part of the startup, it is recommended to carry out a test run of the system until the measuring range is exceeded (output of a diagnostic error) so that the output signal switches to safe state.

#### Caution



The electrical connection and settings in the configuration level up to system startup may only be carried out by qualified personnel.

#### Hybrid mixture:



If a dangerous atmosphere could occur at the mounting site – an atmosphere that is potentially explosive due to a mixture of gases, steam, or mist and at the same time through combustible dusts – then the safety-related characteristic parameters of the gases, steam, or mist and the combustible dusts can change. In such cases the suitability of the intended device is to be checked by an appropriate expert body.

## 4.2 Connection diagram

The connection is made via screw terminals that have slot coding.

**Note:** Please ensure that any terminals that were removed for wiring purposes or to replace the device, are reconnected at the correct position.

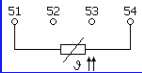
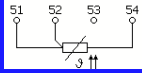
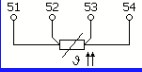
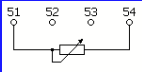
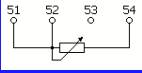
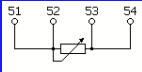

Conductor	Admissible cross section
Rigid or flexible	0.2 to 2.5 mm <sup>2</sup>
Flexible with ferrule with or without plastic sleeve	0.25 to 2.5 mm <sup>2</sup>
AWG	12 to 24
2 rigid/flexible conductors with equal cross section	0.2 to 1 mm <sup>2</sup>
2 flexible conductors with equal cross section, ferrule without plastic sleeve	0.25 to 1 mm <sup>2</sup>
2 flexible conductors with equal cross section, ferrule with plastic sleeve	0.5 to 1.5 mm <sup>2</sup>
AWG according to UL/CUL	12 to 30
Tightening torque of screws: max. 0.6 Nm	

Terminals	Comment	Screw terminals
<b>4.2.1 Analog input (part of the safety channel)</b>		
 <p data-bbox="288 857 404 884">41,42,43,44</p> <p data-bbox="384 812 500 839">51,52,53,54</p> <p data-bbox="55 915 722 964"> <span style="display: inline-block; width: 10px; height: 10px; background-color: #cccccc; border: 1px solid black; margin-right: 5px;"></span> Per default  <span style="display: inline-block; width: 10px; height: 10px; background-color: #0000ff; border: 1px solid black; margin-right: 5px;"></span> Intrinsically safe electrical circuit according to EN 60079-11         </p>	RTD temperature probe in 2-wire circuit	
	RTD temperature probe in 3-wire circuit	
	RTD temperature probe in 4-wire circuit	
	Resistance/potentiometer in 2-wire circuit	
	Resistance/potentiometer in 3-wire circuit	
	Resistance/potentiometer in 4-wire circuit	

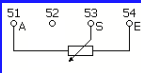
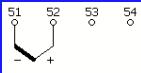
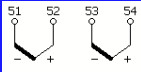
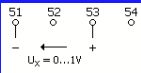
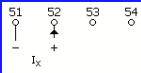
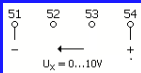
Terminals	Comment	Screw terminals
 <p data-bbox="59 785 722 809">■ Intrinsically safe electrical circuit according to EN 60079-11</p>	<p>Potentiometer/resistance transmitter  A: Starting resistance  S: Slider resistance  E: End resistance</p>	
	<p>Thermocouple</p>	
	<p>Double thermocouple (galvanically isolated)</p>	
	<p>Voltage DC 0 to 1 V (denoted mV input in the setup program)</p>	
	<p>4 to 20 mA</p>	
	<p>0 to 20 mA</p>	
	<p>0 to 10 V</p>	

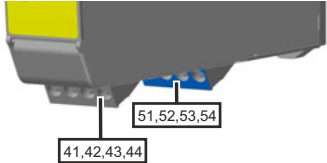
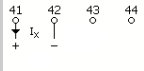
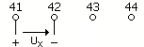
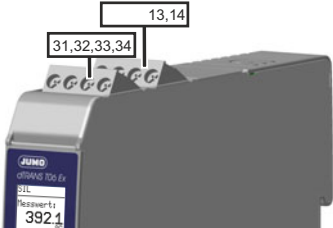
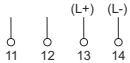
Terminals	Comment	Screw terminals
<b>4.2.2 Analog output (part of the safety channel)</b>		
<b>Note:</b> An open current output will be detected and will lead to an error.		
<b>Remedy:</b> Connect a 470 $\Omega$ resistor and check to see whether the error message disappears.		
	0(4) to 20 mA	
	0(2) to 10 V	
<b>4.2.3 Voltage supply (DC 24 V)</b>		
	<b>DC:</b> (L+) (L-) The device may only be connected to SELV or PELV electrical circuits.	

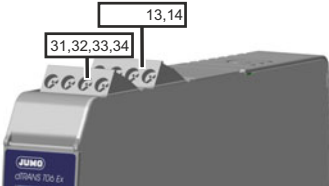
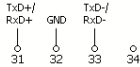

Terminals	Comment	Screw terminals
(3)	<b>USB interface</b> (Device) Micro-B connector, standard (5-pole)	
<b>4.2.4 Extra codes</b>		
	<b>RS485 interface</b>	

■ Per default

### 4.3 Checking the wiring of the intrinsically safe electrical circuit

#### Caution



All screw terminals in the housing must always be tightened to the maximum torque of 0.6 Nm. This also applies to connections that are not required.

## 5 Starting operation of the device

### 5.1 Display and control elements

- \* When the voltage supply is set up, a self-test begins during which the backlight display shows white pixels for 2 s and then black pixels for 2 s. During this time, the LED lights up red and green simultaneously.

The self-test



is followed by a language prompt



and then the main measured value appears:

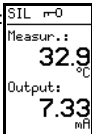

⇒ If an error message appears, see Chapter 13 "Error messages".

### 5.2 Setting the display after device is switched on

The main view appears on the screen in German per default.







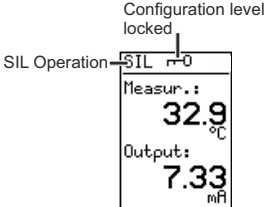
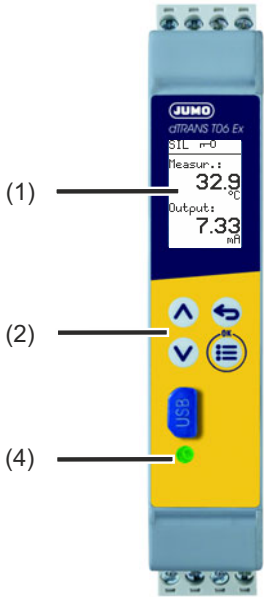

Once a probe has been connected, the device displays a measured value of 24.0 °C and an output signal of 10.38 mA as an example here.

#### Note



If something else is to be displayed after switch-on, this can be adjusted as follows:

⇒ Chapter 9.3.1 "Normal display"

Legend	Comment	Figure
1	<p><b>LCD display</b> Black/white with backlight, 64 x 96 pixels</p> 	
2	<p><b>Keys</b></p> <ul style="list-style-type: none"> <li> Increase value / previous menu item</li> <li> Reduce value / next menu item</li> <li> Back / cancel change</li> <li> One level down in the menu, confirm change</li> </ul>	
4	<p><b>LED</b> Lights up  <b>green</b> if the diagnostic function does not detect any errors. Lights up  <b>red and green simultaneously</b> upon device restart, during simulation of the analog output, and during an active transfer of setup data. Lights up  <b>red</b> if the diagnostic function detects errors (e.g. if the limits for the signal type are exceeded in the signal flow figure below).</p>	

### 5.3 SIL operation

For all device variants, SIL operation is activated per default and shown in the display at the top left.



#### Note



It is possible to deactivate SIL operation in the setup program:

⇒ Chapter 12.6 "Switching on/switching off the SIL extra code"

## 5.4 Signal flow

The following example shows which parameters influence the measured value from the analog input to the analog output.

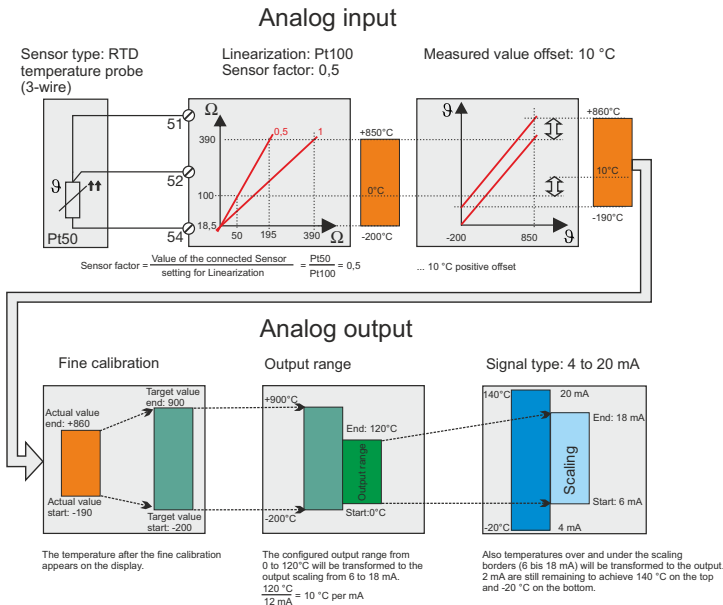

Here is a summary of the parameters from the figure above:

### ▼ Analog input:

Sensor type:	RTD temperature probe (2-wire)
Linearization:	Pt100, IEC 60 751:2008, ITS-90
Noise suppression:	Yes
Sensor factor:	1.00
Line resistance:	0.5 Ohm
Filter time constant:	0.1 s
Measured value offset:	10.00 °C
Fine calibration	
Fine calibration start value (actual):	-190.00 °C
Fine calibration end value (actual):	860.00 °C
Fine calibration start value (target):	-200.00 °C
Fine calibration end value (target):	900.00 °C

### ▼ Analog output:

Signal type:	0 ... 10 V
Output range start:	0.00 °C
Output range end:	120.00 °C
Scaling start:	2.00 V
Scaling end:	8.00 V
Simulation:	off
Reversion of the output:	No reversion
Error signal:	Negative signaling
Replacement value:	-0.20 V
Response to GW error:	active
Signal from diagnosis error:	All errors



## 6 Safety manual



### Warning

All safety-relevant parameters must be validated by the plant operator. For all device variants, SIL operation is activated per default.

Chapter 5.3 describes the settings for SIL operation; in Chapter 7 the default settings are in **(bold)** and the SIL parameters are highlighted in yellow. The setup program enables the data to be read from the device and, once the parameter overview has been verified, transferred back to the device.

Parameter	Value
Sensor type	RTD temperature probe (2-wire)
Linearization	Pt100IEC 60751:2008ITS-90
Temperature difference	10 °C
Temperature compensation	Internal
Fixed value	0.00 °C
Resistance measuring range	400 Ohm
Line resistance	0.0 Ohm
Sensor factor	1.00
Scaling start	0.00 *

### 6.1 Brief description, intended use

⇒ Chapter 1 "Brief description".



## 6.2 Validity of the safety manual



### Note

The evaluation described in this safety manual in terms of functional safety and display of certificates is valid for the specified transmitter in SIL operation, including probe versions.

- ⇒ The connection of RTD temperature probes with 2, 3, and 4-wire technology (variant 1) or double thermocouples (variant 2) is described in the safety manual for RTD temperature probes and thermocouples for connection to the JUMO dTRANS T06 type 707075.  
The probes must also have been qualified for use in the Ex area.
- ⇒ All the specifications below in this chapter refer to connection **variant 3**

## 6.3 Special operating statuses

### 6.3.1 Behavior after a power failure

Analog output issues  $\leq 3.6$  mA.

Once the mains voltage has been restored, the device starts as described in Chapter 5 and converts the measured value at the analog input into the configured output signal.

### 6.3.2 During setup data transfer

(LED lights up red and green simultaneously ) The device is switched to a safe state until the setup data reaches the device and the data has been compared.

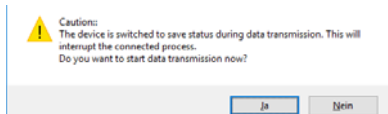

### 6.3.3 After alteration of the configuration level (at the device or through setup)

The device carries out a plausibility check that can also trigger an error message.

- ⇒ Chapter 14 "What to do, if ..." "Check dependent parameters"
- ⇒ Chapter 13 "Error messages"

### 6.3.4 Issue of an error signal (safe state)

In SIL operation, the measured value at the analog input is always issued at the analog output 4 to 20 mA.

The limit values according to NAMUR NE 43 ( $\leq 3.6$  or  $\geq 21$  mA) are only issued when internal errors, probe errors, or a limit value monitoring function (extra code) are identified.

## 6.4 Relevant standards

Type 707075 corresponds to the requirements according to DIN EN 61508 SIL2.

The systematic capability (SC 3) of the hardware and software corresponds to Safety Integrity Level (SIL3).

Depending on the architecture used, it is possible to achieve SIL2 or PL c for HFT=0 (single device) and SIL3 or PL d for HFT=1 (2 devices).

For the safety function up to SIL 3 according to DIN EN 61508 Part 1 to 7:

Functional safety of electrical/electronic/programmable electronic safety-related systems

DIN EN 60730-2-9:

Automatic electrical controls for household and similar use – Part 2-9: Particular requirements for temperature sensing controls

DIN EN ISO 13849-1:

Safety of machinery - Safety-related parts of control systems

DIN EN ISO 13849-2:

Safety of machinery - Safety-related parts of control systems - Part 2: Validation (ISO 13849-2)

## 6.5 Connection possibilities of the sensors

Variant	Connected sensors	Further information
Variant 1	RTD temperature probe with 2, 3, or 4-wire circuit	The connection of RTD temperature probes with 2, 3, and 4-wire technology (variant 1) or double thermocouples (variant 2) is described in the safety manual for RTD temperature probes and thermocouples for connection to the JUMO dTRANS T06 type 707075.
Variant 2	Double thermocouple	
Variant 3	4 to 20 mA	⇒ Chapter 6.5.2 "Safety-relevant parameters"

### 6.5.1 Terms and abbreviations according to DIN EN 61508 and DIN EN 61511.

Name	Description
Actuator	Part of a safety-related system that intervenes in the process to achieve a safe state.
EUC	EUC (equipment under control) Equipment, machine, apparatus, or system used for manufacturing, shaping materials, for transport, medical purposes, or other activities.
E/E/PE	Electrical/electronic/programmable electronic (E/E/PE): based on electrical (E) and/or electronic (E) and/or programmable electronic (PE) technology
Failure	End of the ability of a functional unit to perform a required function.
Diagnostic coverage	Partial reduction in the probability of critical hardware failures due to the use of automatic diagnostic tests.
Error	An abnormal condition that can cause a reduction or the loss of the ability of a functional unit to perform a required function.
Functional safety	A part of overall safety related to the EUC and EUC control system that depends on the proper function of the E/E/PE safety-related system, safety-related systems based on other technology, and external equipment for reducing risk.

Name	Description
Functional unit	Unit consisting of hardware or software or both that is suitable for performing a specified task.
Dangerous failure	<p>Failure of an element and/or subsystem, and/or system involved in implementing the safety function, which</p> <p>a) prevents the safety function being executed on demand (on-demand operation type), or causes the failure of a safety function (operation with continuous demand), so that the EUC transitions to a dangerous or potentially dangerous state; or</p> <p>b) reduces the probability of executing the safety function correctly on demand.</p>
Safe failure	<p>Failure of an element and/or subsystem, and/or system involved in implementing the safety function, which</p> <p>a) causes false triggering of the safety function, switching the EUC (or parts of it) to a safe state, or maintaining a safe state; or</p> <p>a) increases the probability of false triggering of the safety function, switching the EUC (or parts of it) to a safe state, or maintaining a safe state.</p>
Hazard	Potential source of damage
Safety	Freedom from unreasonable risk
Safety function	A function that is performed by an E/E/PE safety-related system, safety-related system based on other technology, or external equipment for reducing risk with the goal of achieving or maintaining a safe state for the EUC taking into consideration a specified dangerous event
Safety integrity	The probability of a safety-related system performing the required safety function under all specified conditions within a specified period of time according to requirements.
Safety Integrity Level (SIL)	One of four discrete levels for specifying the requirement for safety integrity of the safety functions assigned to the E/E/PE safety-related system. Safety integrity level 4 represents the highest level of safety integrity, while safety integrity level 1 represents the lowest.

Name	Description
Safety-related system	A system which both <ul style="list-style-type: none"> <li>- performs necessary safety functions that are required to reach or maintain a safe state for the EUC, and</li> <li>- is designed by itself or with other E/E/PE safety-related systems, safety-related systems based on other technology, or external equipment for reducing risk to achieve the necessary safety integrity for the required safety functions.</li> </ul>
Safety instrumented system (SIS)	Safety instrumented system to perform one or more safety-related functions. A SIS consists of sensor(s), logic system, and actuator(s).
Lambda: $\lambda$	Failure rate per hour
Lambda <b>D</b> angerous: $\lambda_D$	Rate of dangerous failures per hour
Lambda <b>D</b> angerous <b>D</b> etect: $\lambda_{DD}$	Rate of detected dangerous failures per hour
Lambda <b>D</b> angerous <b>U</b> ndetect: $\lambda_{DU}$	Rate of undetected dangerous failures per hour
Lambda <b>S</b> afe: $\lambda_S$	Rate of safe failures per hour
Lambda <b>S</b> afe <b>D</b> etect: $\lambda_{SD}$	Rate of detected safe failures per hour
Lambda <b>S</b> afe <b>U</b> ndetect: $\lambda_{SU}$	Rate of undetected safe failures per hour
BPCS	Basic process control system
DC	<b>D</b> iagnostic <b>c</b> overage
FIT	<b>F</b> ailure <b>i</b> n <b>t</b> ime ( $1 \times 10^{-9}$ per h)
HFT	<b>H</b> ardware <b>f</b> ailure <b>t</b> olerance
PFD	<b>P</b> robability of <b>f</b> ailure on <b>d</b> emand
PFD <sub>avg</sub>	<b>P</b> robability of <b>f</b> ailure on <b>d</b> emand <b>a</b> verage
PFH	<b>P</b> robability of dangerous <b>f</b> ailure per <b>h</b> our

Name	Description
MooN	Architecture with <b>M</b> out of <b>N</b> voting, i.e. N indicates how often the safety function was executed and M indicates how many channels must be working correctly.
MTBF	<b>Mean time between failures</b>
MTTR	<b>Mean time to restoration</b> (mean time to discover the error and repair the system)
MRT	<b>Mean repair time</b> (mean time to repair the system)
SFF	<b>Safe failure fraction</b>
SIL	<b>Safety integrity level</b>
SC	<b>Systematic capability</b>
PTC	<b>Proof test coverage</b> (diagnostic coverage during repeat test)
$T_i$	Proof test interval

### 6.5.2 Safety-relevant parameters

All the specifications below refer to connection **variant 3**

The following parameters were calculated by way of example using the formula in Chapter 6.5.4 for  $T_i = 1, 3,$  and 5 years.

### 6.5.3 Failure rates and SFF for 707075/X-29-XXX (DC 24 V)

<b>Variant 3</b> 4 to 20 mA (without sensor technology 1oo1D architecture)	$\lambda_S$ [FIT]	$\lambda_{DD}$ [FIT]	$\lambda_{DU}$ [FIT]	SFF	PFH (1/h)	PFD <sub>avg</sub> (Proof test A PTC=72.3 %)	PFD <sub>avg</sub> (Proof test B PTC=67.5 %)	PFD <sub>avg</sub> (Proof test C PTC=46.4 %)
$T_i = 1$ year	0	2265.2	157	93 %	$1.57 \times 10^{-7}$	$2.57 \times 10^{-3}$	$2.87 \times 10^{-3}$	$4.17 \times 10^{-3}$
$T_i = 3$ years						$3.57 \times 10^{-3}$	$3.80 \times 10^{-3}$	$4.81 \times 10^{-3}$
$T_i = 5$ years						$4.56 \times 10^{-3}$	$4.72 \times 10^{-3}$	$5.45 \times 10^{-3}$

#### 6.5.4 Calculation of $PFD_{avg}$

The plant operator is to specify the following:

- the proof test interval  $T_i$
- the planned operating duration  $T_M$ , and
- the PTC value for the proof test they performed (A, B, or C)

In this context, the operating duration  $T_M$  must be at least equal to the proof test interval  $T_i$ , but no greater than the lifetime of 10 years.

This must be taken into consideration when evaluating the probability of a dangerous failure  $PFD_{avg}$  of the sensor system. In the case of a single-channel system architecture, the mean probability of a dangerous failure  $PFD_{avg}$  of the transmitter can be calculated from the following formula:

## Berechnungsformel:

$PFD_{avg} = \lambda_{dd} \cdot MTTR + PTC \cdot \lambda_{du} \cdot \left( \frac{T_i}{2} + MRT \right) + (1 - PTC) \cdot \lambda_{du} \cdot \frac{T_M}{2}$	
$\lambda_{dd}$	erkennbare kritische Ausfälle
$\lambda_{du}$	nicht erkennbare kritische Ausfälle
MTTR	<b>M</b> ean <b>T</b> ime <b>T</b> o <b>R</b> estoration, durchschnittliche Zeit zur Entdeckung des Fehlers und Reparatur des Systems
PTC	<b>P</b> roof <b>T</b> est <b>C</b> overage, Anteil der Fehler, die beim Proof test entdeckt werden können
$T_i$	<b>P</b> roof <b>T</b> est <b>I</b> ntervall (Prüfintervall welches der Betreiber selbst festlegen kann)
MRT	<b>M</b> ean <b>R</b> epair <b>T</b> ime, durchschnittliche Zeit zur Reparatur des Systems
$T_M$	<b>M</b> ission <b>T</b> ime, geplante Betriebsdauer (10 Jahre = 87600h)

## Typ 707075, ohne Sensor, Beispiele:

	$\lambda_{dd}$ [FIT]	$\lambda_{du}$ [FIT]	MTTR [h]	PTC <sub>A</sub> [%]	$T_i$ [h]	MRT [h]	$T_M$ [h]	PFD <sub>avg</sub>
A	2265,2	157,0	72	72,3	8760	72	87600	$2,57 \cdot 10^{-3}$
$PFD_{avg} = 2265,2 \cdot 10^{-9} \frac{1}{h} \cdot 72 \text{ h} + 0,723 \cdot 157,0 \cdot 10^{-9} \frac{1}{h} \left( \frac{8760 \text{ h}}{2} + 72 \text{ h} \right) + (1 - 0,723) \cdot 157,0 \cdot 10^{-9} \frac{1}{h} \cdot \frac{87600 \text{ h}}{2} = 2,57 \cdot 10^{-3}$								
	$\lambda_{dd}$ [FIT]	$\lambda_{du}$ [FIT]	MTTR [h]	PTC <sub>B</sub> [%]	$T_i$ [h]	MRT [h]	$T_M$ [h]	PFD <sub>avg</sub>
B	2265,2	157,0	72	67,5	8760	72	87600	$2,87 \cdot 10^{-3}$
$PFD_{avg} = 2265,2 \cdot 10^{-9} \frac{1}{h} \cdot 72 \text{ h} + 0,675 \cdot 157,0 \cdot 10^{-9} \frac{1}{h} \left( \frac{8760 \text{ h}}{2} + 72 \text{ h} \right) + (1 - 0,675) \cdot 157,0 \cdot 10^{-9} \frac{1}{h} \cdot \frac{87600 \text{ h}}{2} = 2,87 \cdot 10^{-3}$								
	$\lambda_{dd}$ [FIT]	$\lambda_{du}$ [FIT]	MTTR [h]	PTC <sub>C</sub> [%]	$T_i$ [h]	MRT [h]	$T_M$ [h]	PFD <sub>avg</sub>
C	2265,2	157,0	72	46,4	8760	72	87600	$4,17 \cdot 10^{-3}$
$PFD_{avg} = 2265,2 \cdot 10^{-9} \frac{1}{h} \cdot 72 \text{ h} + 0,464 \cdot 157,0 \cdot 10^{-9} \frac{1}{h} \left( \frac{8760 \text{ h}}{2} + 72 \text{ h} \right) + (1 - 0,464) \cdot 157,0 \cdot 10^{-9} \frac{1}{h} \cdot \frac{87600 \text{ h}}{2} = 4,17 \cdot 10^{-3}$								

Anmerkung 1:  $1 \text{ FIT} = 1 \cdot 10^{-9} \frac{1}{h}$



## 6.6 Determining the safety integrity level (SIL)

The achievable safety integrity level is determined by the following safety-related parameters:

- Average probability of dangerous failures of a safety function on demand ( $PFD_{avg}$ ),
- Hardware failure tolerance (HFT) and
- Safe failure fraction (SFF).

The specific safety-related parameters for the 707075 measuring system can be found in the table in the "Safety-related parameters" chapter.

The following table shows how the "safety integrity level" (SIL) depends on the "average probability of dangerous failures of a safety function of the entire safety-related system" ( $PFD_{avg}$ ) according to DIN EN 61508. The "low demand mode" is considered here, i.e. the demand rate for the safety-related system averages once a year.

Table for high demand PFH and low demand PFD

Safety Integrity Level (SIL)	Operating mode with high demand rate <b>PFH</b> (high demand mode)	Operating mode with low demand rate <b>PFD<sub>avg</sub></b> (low demand mode)
4	$\geq 10^{-9}$ to $<10^{-8}$	$\geq 10^{-5}$ to $<10^{-4}$
3	$\geq 10^{-8}$ to $<10^{-7}$	$\geq 10^{-4}$ to $<10^{-3}$
2	$\geq 10^{-7}$ to $<10^{-6}$	$\geq 10^{-3}$ to $<10^{-2}$
1	$\geq 10^{-6}$ to $<10^{-5}$	$\geq 10^{-2}$ to $<10^{-1}$

### 6.6.1 Safety integrity of the hardware

According to DIN EN 61508, a distinction must be made between systems of type A and systems of type B.

A subsystem can be considered to be type A if, for the components required to achieve the safety function,

- the failure behavior of all components used is sufficiently defined, and
- the behavior of the subsystem under error conditions can be fully determined, and
- reliable failure data from experience in the field exists for the subsystem to show that the assumed failure rates for detected and undetected dangerous failures are achieved.

A subsystem can be considered to be type B if, for the components required to achieve the safety function,

- the failure behavior of at least one of the components used is not sufficiently defined, or
- the behavior of the subsystem under error conditions cannot be fully determined, or
- no sufficiently reliable failure data from experience in the field exists for the subsystem to support the utilized failure rates for detected and undetected dangerous failures.

The type 707075 transmitter corresponds to a type B system.

The following table shows the achievable safety integrity level (SIL) depending on the safe failure fraction (SFF) and the hardware failure tolerance (HFT) for safety-related type B subsystems.

For 707075 the following table applies:

Safe failure fraction (SFF)	Hardware failure tolerance (HFT) for type B		
	0	1	2
< 60 %	Not allowed	SIL 1	SIL 2
60 to < 90 %	SIL 1	SIL 2	SIL 3
90 to < 99 %	SIL 2	SIL 3	SIL 4
≥ 99 %	SIL 3	SIL 4	SIL 4

## 6.6.2 Safety-relevant system properties

The type 707075 transmitter is realized using 1oo1D architecture.

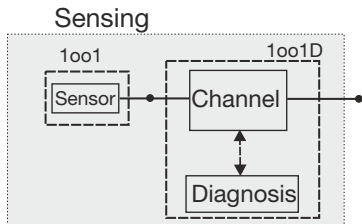

**The following are monitored:**

- Probe break
- Probe short circuit
- Random hardware failure in the sensor channel

Safety feature	Requirement / comment
SIL	SIL2
Systematic capability of HW and SW	SC3
Operating mode in terms of safety function	Operating mode with low and high demand rate possible on a customer-specific basis
Safety-critical inputs	Temperature sensor input for double thermocouple and RTD temperature probe with 2, 3, and 4-wire technology, 4-20 mA current input
Safety-relevant inputs	Setup and parameterization
Safety-critical output	Analog output 4 to 20 mA
Subsystem type	Type B

Safety feature	Requirement / comment
707075 safety architecture	1oo1D This corresponds to architecture category 2 according to DIN EN ISO 13849, i.e. the system has a safety channel and an additional diagnostics channel.
Hardware failure tolerance	HFT = 0
Safe failure fraction	SFF $\geq$ 90 %
CCF	If the system is used redundantly: calculation according to DIN EN 61508 Part 7 Appendix D and/or DIN EN ISO 13849-1 Table F.1 at least 65
Average failure probability of a safety function on demand (overall system)	SIL 2: Low demand: $\text{PFD}_{\text{avg}} < 10^{-2}$ High demand: $\text{PFH} < 10^{-6}$
Interval for repeat test ( $T_i$ )	max. 10 years
Lifetime	10 years
Planned operating duration Mission Time ( $T_M$ )	max. 10 years
Architecture according to DIN EN ISO 13849-1	Category 2
MTTF <sub>d</sub> -DC <sub>avg</sub> according to DIN EN ISO 13849-1 Table K.1	PL c: $\geq$ 22 years ( $\text{DC}_{\text{avg}} \geq 60$ %)
Modes of operation and software class according to DIN EN 60730-2-9	The system has the following modes of operation: 2K Only in the case of redundancy: 2N Software class C

### 6.6.3 Redundant use of the system

If the transmitter is used redundantly ( $\text{HFT} > 0$ ), it can meet SIL 3 according to DIN EN 61508-2, 7.4.3.2 (systematic capability) and 7.4.4.2.4 (suitability of the architecture).

SIL of the sensor used	Systematic capability (SC) of the sensor used	Max. achievable SIL of the system with 1oo1 architecture for the sensor and temperature transmitter	Max. achievable SIL of the system with redundant use (HFT = 1) of the sensor and temperature transmitter
1	1	1	1
1	2	1	2
2	2	2	2
2	3	2	3
3	3	2	3

## 6.7 Determining the performance level (PL)

The following safety-related parameters are required to determine the performance level of components/devices:

As further parameters to be observed, operational aspects such as the demand rate and/or the test rate of the safety function can also influence the resulting PL.

Excerpt from DIN EN ISO 13849-1



### Note

This excerpt contains references to the complete DIN EN ISO 13849-1 body of standards, which are therefore not reproduced in this chapter.

## 6.7.1 Terms and abbreviations according to standards series DIN EN ISO 13849

Formula symbol or abbreviation	Description	Definition or location
PL (a, b, c, d, e)	Designation for the Performance Level	Table 3 in DIN EN ISO 13849-1
AOPD	Active opto-electronic protective device (e.g. light barrier)	Annex H
B, 1, 2, 3, 4	Designation for the categories	Table 7
$B_{10d}$	Number of cycles in which a dangerous failure occurred in 10 % of a random sample of the observed pneumatic or electromechanical components that are subject to wear (mean time to dangerous failure)	Annex C
Cat.	Category	3.1.2
CC	Current Converter	Annex I
CCF	<b>C</b> ommon <b>c</b> ause <b>f</b> ailure	3.1.6
DC	<b>D</b> iagnostic <b>c</b> overage	3.1.26
$DC_{avg}$	Average diagnostic coverage	E.2
MTTF	Mean Time To Failure	Annex C
$MTTF_c$	Mean Time to Critical Failure	3.1.25
$MTTF_d$	Mean Time to Dangerous Failure	
n, N, $\bar{N}$	Number of units	6.3, D.1
$N_{low}$	Number of SRP/CS with $PL_{low}$ in an SRP/CS combination	6.3
PL	Performance Level	3.1.23
PLC	Programmable Logic Controller	Annex I
$PL_{low}$	Lowest performance level of an SRP/CS in an SRP/CS combination	6.3

Formula symbol or abbreviation	Description	Definition or location
$PL_f$	Required Performance Level	3.1.24
$T_M$	<b>Mission Time</b> (functional life, designated period of utilization)	3.1.28
$T_{10d}$ value	Reference value for a preventative replacement (10 % of the B10d value). At this value, a dangerous failure has already occurred for approx. 63 % of all components. In this case, the standard DIN EN ISO 13849-1 recommends replacement.	

The following table shows the achievable PL level:

### 6.7.2 Calculations of the DIN EN ISO 13849-1 performance level – 707075/X - 29/XXX (DC 24 V)

Variant	$MTTF_d$	$DC_{avg}$	CCF	PL
4 to 20 mA (without sensor technology 1oo1D architecture)	47 years	93.52 %	75 points	PL c

Type 707075 meets the architecture requirements for a category 2 system.

The necessary limit values according to DIN EN ISO 13849-1, table K.1 for **performance level c**, and the fundamental and established safety principles are adhered to for all voltage versions of type 707075 considered.

If the temperature transmitter is used redundantly (i.e. HFT = 1), the requirements for a category 3 system are adhered to. The necessary limit values according to DIN EN ISO 13849-1, table K.1 for **performance level d** are met here.

The following table can be used to determine the quantitative PL provided that the  $MTTF_d$  value for the sensor is 100 years. The DC achieved by the temperature transmitter to detect sensor errors is assumed to be  $\geq 60$  % for redundant use (HFT = 1).

PL of the sensor used MTTF <sub>d</sub> = 100 years	Max. achievable PL of the system with 1oo1 architecture	Max. achievable PL of the system with redundant use (HFT = 1) DC ≥ 60 %
b	b	d
c	c	d
d	c	d
e	c	d

### 6.7.3 Risk reduction through the control system

In order to achieve the safety objectives for the machine, the entire design process must be followed. The design of the SRP/CS (safety-related part of a control system) is a necessary part of the entire design process in order to provide the risk reduction required. This can only be achieved with a PL that achieves the required risk reduction. By installing a protective guard or protective device, the design of the SRP/CS is part of the risk reduction strategy.

The features of each safety function (see section 5) and the required performance level must be described and documented in the specification of the safety requirements.

In this part of DIN EN ISO 13849-1, the performance levels are defined in the form of the probability of a dangerous failure per hour. Five performance levels (a to e) have been specified (see table).

Performance Level (PL)	Average probability of a dangerous failure per hour 1/h
a	$\geq 10^{-5}$ to $< 10^{-4}$
b	$\geq 3 \times 10^{-6}$ to $< 10^{-5}$
c	$\geq 10^{-6}$ to $< 3 \times 10^{-6}$
d	$\geq 10^{-7}$ to $< 10^{-6}$
e	$\geq 10^{-8}$ to $< 10^{-7}$



Performance Level (PL)	Average probability of a dangerous failure per hour 1/h
NOTE: in addition to the average probability of a dangerous failure per hour, further measures are required to achieve the PL.	

## 6.8 Other applicable device documentation

For the transmitter type 707075, the measures, values, and requirements specified in this operating manual regarding installation, electrical connection, function, and startup must be observed.

## 6.9 Behavior during operation and in case of malfunction

The behavior during operation is described in Chapter 5 "Starting operation of the device" and the behavior in case of malfunction is described in Chapter 13 "Error messages".

A functional test must be performed after startup, repair in the safety system, or a change in safety-related parameters.

If an error is detected during a functional test, measures must be taken to once again ensure the functional capability of the safety system. This, for example, can be done by replacing the logic unit.

Appropriate documentation of the tests performed is recommended.

## 6.10 Regular tests

The device test can be carried out as follows:

- Proof test A: complete test by the manufacturer; the device must be sent to the manufacturer for this purpose.
- Proof test B: comprehensive test; the device must be removed from the operating facility for this purpose.
- Proof test C: simplified test; the device can remain in the operating facility for this purpose.

Tests on a device without a sensor can be conducted using corresponding sensor simulators (resistance decade, reference voltage source, etc.). The accuracy of the measuring devices or multimeter used must meet the device specification.

### 6.10.1 Proof test A

(corresponds to factory calibration)

For a complete check, the device must be removed from the operating facility and sent to the manufacturer.

⇒ For service addresses see back cover

Voltage supply	Detection of dangerous undetected failures ( $\lambda_{DU}$ )	PTC
DC 24 V +10/-15 %	0.723	72.3 %

### 6.10.2 Proof test B

With proof test B, the following values for the proof test coverage (PTC) can be achieved:

Voltage supply	Detection of dangerous undetected failures ( $\lambda_{DU}$ )	PTC
DC 24 V +10/-15 %	0.675	67.5 %

Step	Action	Remark
1	Test the resistance between the following connections with an ohmmeter: 41 to 42: > 10 k $\Omega$	Verification that there is no short circuit in the area of the analog output connection terminal.
2	Test the resistance between the following connections with an ohmmeter: 52 to 51: > 10 k $\Omega$ 53 to 51: > 10 k $\Omega$ 54 to 51: > 10 k $\Omega$ 53 to 52: > 10 k $\Omega$ 54 to 52: > 10 k $\Omega$ 54 to 53: > 10 k $\Omega$	Verification that there is no short circuit in the area of the measurement input connection terminal.
3	Connect short-circuit jumper between connection 41(+) and connection 42(-), restore energy supply connection, and switch on test piece. Configure test piece for connection to RTD temperature probe (RTD) sensor type in 4-wire technology and configure analog output to current signal (4 mA to 20 mA; error signal: negative signaling). Connect current meter between connection 54(+) and 51(-) and measure the current: 200 $\mu$ A to 300 $\mu$ A can be expected.	Verification that components determining the current are OK.
4	Connect resistance decade for simulating the input signal in accordance with the chosen configuration. Verify whether the expected value (display value) corresponds to the input signal. Test the current device status of the test piece using the setup program. Status must be 'OK'. If, for example, Pt100 is configured, 0 °C must be displayed for 100 $\Omega$ at the input.	Verification that there is no error status internally if the display is correct without error signaling.

Step	Action	Remark
5	Produce line break for each of the 4 lines. The test piece must signal an error (display and LED).	Verification of proper function of the probe break/line break detection.
6	<p>Switch off test piece and replace short-circuit jumper at the analog output with the current meter; connection 41(+) and connection 42(-). Switch on test piece again.</p> <p>Check output signal by applying a corresponding reference signal using a resistance decade at two points; for the start of measurement (measuring range start up to +20 % of the range) and for the end of measurement (measuring range end up to -20 % of the range).</p> <p>The analog output signal corresponding to the reference signal must be within the safety measurement deviation.</p> <p>Furthermore, the display value must correspond to the reference signal according to the configuration.</p>	Verification that the measuring chain for RTD is within the safety measurement deviation.
7	Disconnect line to the measurement input connection 51. The test piece must signal an error (display and LED). The current meter must display a value $\leq 3.6$ mA as an analog output signal.	Verification in the event of a malfunction that the analog output signal corresponds to failure information A, NE 43.
8	<p>Restore line to the measurement input connection 51. Both the display and the current meter at the analog output must display values that correspond to the input signal present close to the measuring range end.</p> <p>The test piece must be in SIL operation and/or have a SIL configuration.</p> <p>Disconnect the line of the current meter at connection 42(+). The test piece must signal an error after approx. 5 s.</p>	Verification that, in the event of an interruption to the output signal path (current signal), the internal test for a correct output signal identifies the interruption of the signal path and signals it.

Step	Action	Remark
9	<p>If active, deactivate SIL operation of the test piece.</p> <p>Configure test piece for connection to the thermocouple sensor type, NiCr-Ni, type 'K', internal cold junction, and configure analog output to current signal (4 mA to 20 mA; error signal: negative signaling).</p> <p>Connect current meter between connection 54(+) and 51(-) and measure the current. No current must be measurable (<math>\sim 0 \mu\text{A}</math>).</p>	<p>Verification that the power source is switched off for the RTD temperature probe in the thermocouple configuration.</p>
10	<p>Connect short-circuit jumper between connection 52(+) and connection 51(-). Check whether the temperature displayed by the display corresponds to the ambient temperature with a deviation of <math>\pm 5 \text{ }^\circ\text{C}</math>.</p>	<p>Verification of proper function of the acquisition of the cold junction temperature for thermocouples.</p>
11	<p>Configure test piece for connection to the double thermocouple sensor type, NiCr-Ni, type 'K', internal cold junction, and configure analog output to current signal (4 mA to 20 mA; error signal: negative signaling).</p> <p>Test the resistance between the following connections with an ohmmeter: 53 to 51: display <math>&lt; 5 \Omega</math></p>	<p>Verification of proper function for the second thermocouple.</p>
12	<p>Switch off test piece and connect current meter using a burden of <math>500 \Omega</math> between connections 42(+) and 41(-).</p> <p>Switch on test piece and configure analog output for simulation of current output signal 21.2 mA. The output signal acquired using the current meter must be 21.18 mA to 21.22 mA. Configure analog output for simulation of current output signal 3.6 mA. The output signal acquired using the current meter must be 3.59 mA to 3.61 mA.</p>	<p>Verification that the output driver stage of the analog output can drive the maximum admissible burden.</p>

### 6.10.3 Proof test C

With proof test C, the following values for the proof test coverage (PTC) can be achieved:

Voltage supply	Detection of dangerous undetected failures ( $\lambda_{DU}$ )	PTC
DC 24 V +10/-15 %	0.464	46.4 %

Step	Action	Remark	
1	Test the current device status of the test piece with the setup program. Status must be 'OK'		
2	If active, deactivate SIL operation of the test piece. Configure analog output for simulation of current output signal. Simulate the following output signal values and verify either using downstream devices in the operating facility or using a current meter that is additionally connected:	Verification of the proper function of the analog output including whether the error signal values can be generated.	
	<b>Simulated value:</b>		<b>Expected measured value:</b>
	3.6 mA		3.59 to 3.61 mA
	8 mA		7.99 to 8.01 mA
	16 mA		15.99 to 16.01 mA
	21.2 mA	21.19 to 21.21 mA	
3	Reactivate SIL operation. Disconnect the line of the analog output signal at connection 42(+). The test piece must signal an error after approx. 5 s.	Verification that, in the event of an interruption to the output current signal, the internal test identifies the interruption of the signal path and signals it.	



### Warning

After the mission time expires, the systems no longer meet the requirements according to their SIL certification.

#### 6.10.4 Recommended tests for temperature probes

To ensure safe and reliable operation of the thermometers, the following service and maintenance work must be performed: The following tests are recommended at certain intervals:

- Every 12 months, the insulation resistance of the measuring circuit must be measured against the protection fitting (for thermocouples: only for the insulated measuring circuit; in the case of multiple measuring circuits, the insulation test must also be performed between the individual measuring circuits). The minimal insulation resistance at room temperature should be 100 M $\Omega$  at 100 V.
- Damage and corrosion of thermometers – protection tubes
- Corrosion and correct positioning of the contacts and terminals of cable connections
- Seals of terminal heads and cable entries
- Interruptions due to "knocking" on the thermometer/measuring insert

Since the maximum operating temperature influences the drift behavior, the thermometer should be recalibrated or replaced at certain intervals to ensure reliable and precise temperature measurement. The testing intervals are listed in the table below:

Maximum operating temperature	Pt – RTD temperature probe	Thermocouples
200 °C	5 years	5 years
550 °C	2 years	5 years
700 °C	1 year	2 years
1000 °C		Non-precious metal 1 year Precious metal 2 years
1500 °C		1 year

---

## 7 ATEX

### 7.1 Ignition protection type "i"

#### 7.1.1 Associated, intrinsically safe electrical apparatus according to EN 60079-11

##### 7.1.1.1 Function of intrinsic safety

The ignition protection type intrinsic safety "i" makes use of the fact that a certain energy is required in order to ignite a potentially explosive atmosphere. This is dependent upon the composition of the potentially explosive atmosphere.

An electrical circuit is intrinsically safe if it prevents this energy level from being exceeded, thus preventing an ignition either through switching sparks or a thermal effect, under certain test conditions and taking into consideration certain safety margins.

##### 7.1.1.2 Definitions of intrinsic safety

An intrinsically safe electrical circuit is a circuit in which neither a spark nor a thermal effect occurring under the conditions specified in EN 60079-11, which include uninterrupted operation and defined fault conditions, may cause the ignition of a certain potentially explosive atmosphere.

The energy of the electrical circuit is limited such that it cannot cause an ignition. This applies to both spark formation and thermal effects. The test conditions with specific potentially explosive atmospheres are specified. The tests comprise uninterrupted operation and defined fault conditions.

##### 7.1.1.3 Electrical apparatus:

Electrical apparatus is the collective term for electrical components and electrical circuits or parts of electrical circuits generally found together within a single housing.

##### 7.1.1.4 Intrinsically safe electrical apparatus:

Electrical apparatus in which all electrical circuits are intrinsically safe.

##### 7.1.1.5 Associated electrical apparatus:

Electrical apparatus in which not all electrical circuits are intrinsically safe. However, in terms of the design, the non-intrinsically



safe electrical circuits cannot have an effect on the intrinsically safe electrical circuits.

The associated apparatus is identified through brackets: e.g. II (1) G [Ex ia Ga] IIC.

Associated electrical apparatus can be used in potentially explosive areas provided it has the corresponding protection (ignition protection type according to EN 60079-0). In the event of insufficient protection, it must be used outside of the potentially explosive area.

**Example:**

The type 707075 is not in the potentially explosive area; however, it is connected to a thermocouple in the potentially explosive area. Only the input circuit marked in blue for type 707075 is intrinsically safe.

### 7.1.2 Intended use

Type 707075 is a safety device designed according to Directive 2014/34/EU, chapter 1(1)(b) for measuring temperatures directly using resistance probes or thermocouple probes, or other physical measurands such as pressure, with the aid of a suitable transmitter and the use of a 4 to 20 mA current input.

The stipulations and requirements for use specified in this document must be taken into consideration.



**Important information:**

Thermocouples should be evaluated with at least the requirements of EN 60584 or DIN 43710. RTD temperature probes should be evaluated with at least the requirements of EN 60751. Parameter values such as response rate, temperature stability, age drift, self-heating behavior, failure rates, fault models, etc. should likewise be taken into account.

Type 707075 is associated apparatus that may only be used outside the Ex zone.

Another use or one that goes beyond the specified use ? with respect to use in potentially explosive areas ? is considered as not being in accordance with the intended use.

Liability for resulting damages cannot be assumed.

Type 707075 is built according to the relevant standards and directives as well as to the applicable safety regulations. Nevertheless, improper use may lead to personal injury or material damage.

To avoid danger, only use type 707075:

- For the intended use

- When in good order and condition
- Under consideration of this operating manual

**DANGER!**

The Ex approval becomes null and void if type 707075 is used contrary to its intended use or if the safety requirements in this operating manual are not complied with.

### 7.1.3 Installation regulations

If electrical apparatus is used in plants and ambient conditions with the "intrinsic safety" ignition protection type, the obligations of the applicable installation regulations according to EN 60079-14 "Explosive atmospheres – Part 14: Electrical installations design, selection and erection" are to be considered along with other applicable requirements.



The type of zone separation as well as the cable selection must be implemented or selected in such a way that the defined zone classifications and their requirements continue to be in place.

## 7.2 Identification marking for ATEX ignition protection type "i"

according to ATEX directive 2014/34/EU and the EN standards EN 60079-11

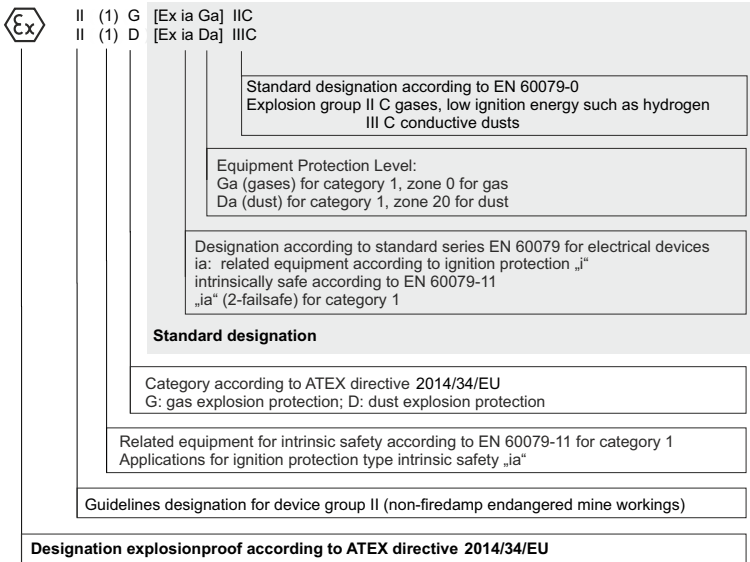

## 7.3 Safety device according to EN 50495 according to ATEX ignition protection type "e" and "t"

	II	(2)	G	[Ex eb Gb]	IIC
	II	(1)	D	[Ex ta Da]	IIIC
	II	(2)	D	[Ex tb Db]	IIIC
<p>Standard designation according to EN 60079-0 Explosion group II C gases, low ignition energy such as hydrogen III C conductive dusts</p>					
<p>Equipment Protection Level: Gb: for use in zone 1 or 2 for gases Da: for use in zone 20, 21 or 22 for dust Db: for use in zone 21 or 22 for dust</p>					
<p>Designation according to series of standards EN 50495 <sup>1)</sup> "eb" increased safety for category 2, b: zone 1 or 2 for gas "ta" protection with housing for category 1, a: zone 20, 21 or 22 for dust "tb" protection with housing for category 2, b: zone 21 or 22 for dust Designation according to series of standards EN 60079 for electrical devices ignition protection "e" increased safety according to EN 60079-7 ignition protection "t" dust explosion protection with housing acc. to EN 60079-31</p>					
<b>Standard designation</b>					
<p>Category according to ATEX directive 2014/34/EU G: gas explosion protection D: dust explosion protection</p>					
<p>Safety devices according to EN 50495 - for category 2 applications for ignition protection type increased safety "e" according to EN 60079-7 - for category 1 applications for ignition protection type with housing „ta" according to EN 60079-31 - for category 2 applications for ignition protection type with housing „tb" according to EN 60079-31</p>					
<p>Guidelines designation for device group II (non-firedamp endangered mine workings)</p>					
<b>Designation explosionproof according to ATEX directive 2014/34/EU</b>					

1.) The monitored electrical equipment is not a potential ignition source in normal operation

### 7.3.1 Safety device according to EN 50495

The standard EN 50495, harmonized within the scope of Directive 2014/34/EU, stipulates requirements for electrical apparatus that performs one or more safety function(s) for explosion protection. Discrete and complex safety devices whose protective function is controlled by software are evaluated using measures from

EN 50495. By means of the Safety Integrity Level (SIL) from EN 61508, EN 50495 defines the necessary safety level for monitoring potential ignition sources.

It is important to note the requirement from EN 50495 in Annex E, which states the following (paraphrased here): *"If a device contains more than one potential ignition source, suitable measures must be applied for each of these ignition sources. Combined apparatus must comply with the relevant standards EN 60079-0 and (EN 61241-0 integrated into EN 60079-0) according to the category to be achieved."*

Type 707075 is installed outside the apparatus in a non-potentially explosive area. Using e.g. a probe attached in the apparatus, it monitors the temperature of a bearing, which is considered a potential ignition source in the apparatus. The probe lines protruding into the potentially explosive area are intrinsically safe and type 707075 is therefore identified accordingly as "associated apparatus".

⇒ Chapter 7.2 "Identification marking for ATEX ignition protection type "i"

It is only admissible to increase the failure tolerance (HFT) and thus increase the device category for the combined apparatus using type 707075 if there are no other ignition hazards other than the one addressed by type 707075, and the higher device category poses no additional requirements on the combined apparatus.

The scope of EN 50495 does not include safety devices for non-electrical apparatus, which are recorded in EN 80079-37 (ignition protection type "h").

⇒ Chapter 7.5 "Ignition source monitoring "h" according to EN 80079-37"

## 7.4 Identification marking for ATEX ignition protection type "h"

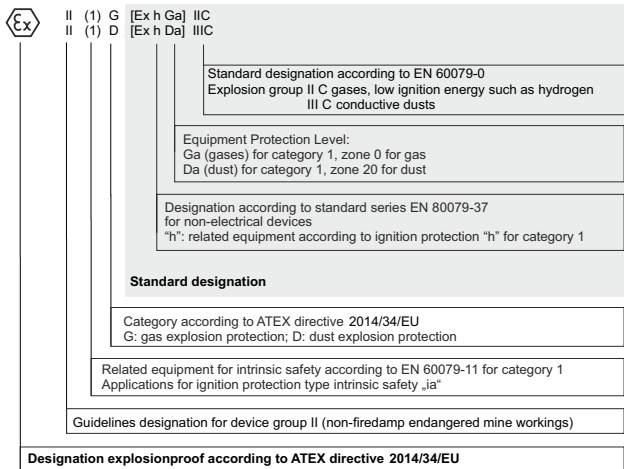

## 7.5 Ignition source monitoring "h" according to EN 80079-37

### 7.5.1 Ignition source monitoring "b"

Ignition protection type whereby mechanical or electrical devices are used in conjunction with non-electrical devices in order to reduce, either manually or automatically, the probability that a potential ignition source will become an actual ignition source.

## 7.5.2 Types of ignition protection system

In order to determine the monitoring parameters, EN 80079-37 makes reference to ISO 80079-36. The use of ignition protection systems is shown in table 1 of EN 80079-37. The use of type b1 and type b2 ignition protection systems is described here. The use of the ignition protection systems b1 or b2 depends on the EPL and the occurrence of the potential ignition source.

With the dTRANS T06 Ex 707075, ignition protection system b2 can only be achieved using redundancy (HFT = 1).

If, for example, the EPL is Ga and Da (zone 0 and zone 20) and a potential ignition source needs to be monitored during an expected malfunction, two dTRANS T06 units (HFT = 1) must be used.

If the potential ignition source only becomes dangerous during a rare malfunction, ignition protection system b1 (HFT = 0) is sufficient and only one dTRANS T06 unit is required.

Monitoring a potential ignition source which can become dangerous in standard operation is not admissible for EPL Ga and Da (zone 0 and zone 20).

In this case, the apparatus concept must be revised.

The necessary ignition protection system must be determined according to table 1 of EN 80079-37.

The necessary specifications for the JUMO dTRANS T06 Ex for use in the aforementioned ignition protection systems can be found in Chapter 6.6.2 "Sicherheitsrelevante Systemeigenschaften".

## 7.5.3 Using the types of ignition protection system

The types of ignition protection system listed in table 1 or table 2 of EN 80079-37 must be used in accordance with the requirements for the EPL. Following a warning signal, the EPL can be ensured through either a manual or automatic intervention.

The user of the product is responsible for selecting the type of intervention (automatic or manual). This selection also depends, among other things, on which downstream logic device and actuators have been chosen.

## 7.5.4 Identification marking

Safety devices which are intended to be part of a type b1 or b2 ignition protection system and which are not intended for installation in potentially explosive atmospheres, must be identified with [Ex h].

## 8 IECEx

### 8.1 Intended use

Type 707075 is associated apparatus that may only be used outside the Ex zone.

Another use or one that goes beyond the specified use ? with respect to use in potentially explosive areas ? is considered as not being in accordance with the intended use. According to ATEX it is considered an [Ex i] device

### 8.2 Identification marking for IECEx ignition protection type "ia":

The nameplate is affixed to the side of the device.



- [Ex ia Ga] IIC Associated apparatus which is set up outside the gas atmosphere but the intrinsically safe electrical circuit "ia" (protection through 2 protective measures) leads into zone 0.
- [Ex ia Da] IIIC Associated apparatus which is set up outside the dust atmosphere but the intrinsically safe electrical circuit "ia" (protection through 2 protective measures) leads into zone 20.

Standard designation according to IEC 60079-0  
Explosion group II C gases, low ignition energy such as hydrogen  
III C conductive dusts

Equipment Protection Level:  
Ga (gases) for category 1  
Da (dust) for category 1

Standard designation according to standard series IEC 60079 for electrical devices  
ia: related equipment according to ignition protection „i“  
intrinsically safe according IEC 60079-11, „ia“ (2-failsafe) for category 1



### 8.3 Identification marking for IECEx ignition protection type "h"



[Ex h Ga] IIC Associated apparatus which is set up outside the gas atmosphere  
[Ex h Da] IIIC Associated apparatus which is set up outside the dust atmosphere

Standard designation according to IEC 60079-0  
Explosion group II C gases, low ignition energy such as hydrogen  
III C conductive dusts

Equipment Protection Level:  
Ga (gases) for category 1, zone 0 for gas  
Da (dust) for category 1, zone 20 for dust

Designation according to standard series EN 80079-37 for non-electrical devices  
"h": related equipment according to ignition protection "h" for category 1

## 8.4 Excerpt of important device data

Contents	Description	Further information
Name of the manufacturer	JUMO GmbH & Co. KG	⇒ See back of this operating manual
Address	Moritz-Juchheim-Straße 1 36039 Fulda Germany	
Description of the test piece Device type	JUMO dTRANS T06 Ex 707075	⇒ Chapter 2 "Identifying the device version"
Ex identification marking	[Ex ia Ga] IIC [Ex ia Da] IIIC	⇒ Chapter 8.2 "Identification marking for IECEx ignition protection type "ia":"
Compilation of the ExTR documents and additional information	IECEx Test Report Cover IECEx Test Report: IEC 60079-0 Edition 6 IECEx Test Report: IEC 60079-11, Edition 6	⇒ Specified standards
Certificate number	IECEx TUN 19.0005	⇒ Chapter 15.4 "IECEx"
Protection type	Min IP20	⇒ Chapter 11.9 "Housing"
Admissible ambient temperature range (°C)	-10 to +70 °C	⇒ Chapter 11.8 "Environmental influences"
Special conditions for use of the device	The electrical connection of intrinsically safe electrical circuits must only be established when the device is de-energized.	



## 9 Configuration

### 9.1 Overview

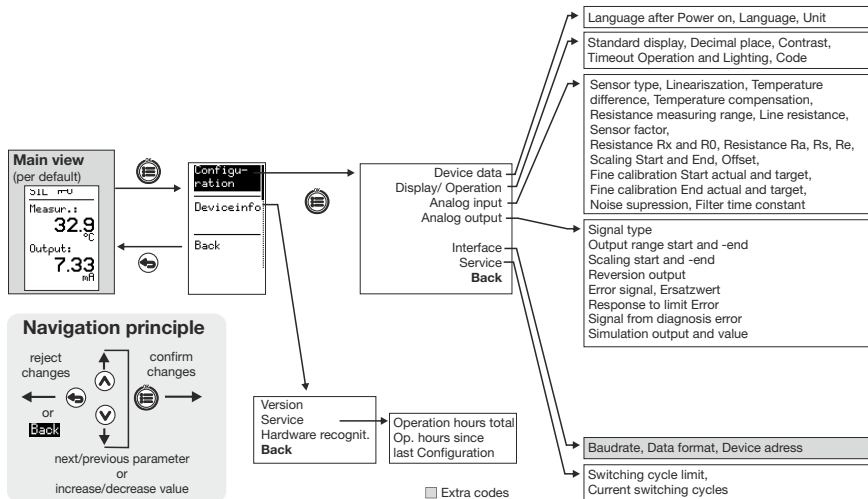

All the parameters are freely accessible, but they can be locked via a code on the device or with the setup program. Default settings are shown in **(bold)**. All parameters are listed in the following tables. Parameters which are not required are automatically hidden depending on the setting.

## 9.2 Device data

Parameter	Comment	Value range (default setting in <b>bold</b> )
<b>9.2.1 Language</b>	German	<b>German</b> , English, French, Spanish
	English	
	French	
	Spanish	
<b>9.2.2 Language prompt after "power on"</b>	Here you can select whether a language prompt is to appear when the device is switched on.	<b>ON</b> , OFF
<b>9.2.3 Unit</b>	A unit for the measured value can be set here.	°C, °F, %, text
	°C	
	°F	
	%	
	Text: Via the setup program, 9 characters can be entered here for another unit, e.g. Pa (Pascal)	

## 9.3 Display/operation

Parameter	Comment	Value range (default setting in <b>bold</b> )
9.3.1 Normal display	This sets the view that appears after the voltage supply is switched on. ⇒ Chapter 9.1 "Overview"	<b>Main view</b> , bar graph, limit value, drag indicator, TAG no. and info text, I/O info
	Main view	
	Bar graph	
	Limit value	
	Drag indicator	
	TAG-no. and info text	
	I/O info  To display the connection diagram of sensor input, signal output, as well as the optional interface assignment	
9.3.2 Decimal place	No decimal place	<b>None</b> , one, two
	One	
	Two	
9.3.3 Contrast	<b>Screen contrast:</b> Difference in brightness between black and white pixels	0 to 5 to 10

Parameter	Comment	Value range (default setting in <b>bold</b> )
<b>9.3.4 Lighting</b>	<p>Here, the backlight of the display is set.</p> <p><b>Always off:</b> always switched off</p> <p><b>Always on:</b> always switched on</p> <p><b>When key is pressed:</b> The backlight is only switched on when the keys are operated and it lights up until the time for the lighting timeout has expired.</p>	Always off, <b>Always on</b> , When key is pressed
<b>9.3.5 Lighting timeout</b>	This setting is only available for key-activated lighting. Here you can select how long the backlight should remain active after the last press of a key.	0 to <b>30</b> to 100 sec
<b>9.3.6 Operation timeout</b>	<p>Here, the waiting period is set for returning from the configuration level to the normal display.</p> <p>⇒ Chapter "Operating overview"</p> <p>0 means: no automatic return</p>	0 to <b>30</b> to 100 sec
<b>9.3.7 Code</b>	<p>To prevent unintentional changes to configuration data, a code for locking the configuration level can be set here.</p> <p>0 means: code request switched off</p> <p><b>Note</b></p> <p> If the code is forgotten, a new code can be transferred to the device via the setup program.</p> <p>⇒ Chapter 12.3 "Forgotten the code?"</p>	0 to 9999

## 9.4 Analog input

Parameter	Comment	Value range (default setting in <b>bold</b> )
9.4.1 Sensor type	RTD temperature probe in 2-wire circuit	-
	<b>RTD temperature probe in 3-wire circuit</b>	-
	RTD temperature probe in 4-wire circuit	-
	Resistance/potentiometer in 2-wire circuit	-
	Resistance/potentiometer in 3-wire circuit	-
	Resistance/potentiometer in 4-wire circuit	-
	Resistance transmitter	-
	Thermocouple	-
	<b>Double thermocouple</b>	-
	mV input (0 to 1 V)	-
	<b>4 to 20 mA</b>	-
	0 to 20 mA	-
	0 to 10 V	-

■ SIL operation



<b>9.4.2 Linearization</b>	<b>Comment</b>	<b>Measuring range</b>
Linear	No sensor linearization	-
<b>Pt100</b>	<b>IEC 60751:2008</b>	<b>-200 to +850 °C</b>
Pt500, Pt1000	IEC 60751:2008	-200 to +850 °C
Pt50 GOST, Pt100 GOST	GOST 6651- 2009 A.2	-200 to +850 °C
Ni100, Ni500, Ni1000	DIN 43760:1987-09	-60 to +250 °C
Ni100 GOST	GOST 6651-2009 A.5	-60 to +180 °C
Cu50 GOST, Cu100 GOST	GOST 6651-2009 A.3	-180 to +200 °C
Pt13Rh-Pt "R"	DIN EN 60584-1:2014	-50 to +1768 °C
Pt10Rh-Pt "S"		
Pt30Rh-Pt6Rh "B"		-50 to +1820 °C
Fe-CuNi "J"		-210 to +1200 °C
Cu-CuNi "T"		-200 to +400 °C
NiCr-Ni "E"		-200 to +1000 °C
NiCr-Ni "K"		-200 to +1300 °C
NiCrSi-NiSi "N"		
Fe-CuNi "L"	DIN 43710:1985-12	-200 to +900 °C
Cu-CuNi "U"	DIN 43710:1985-12	-200 to +600 °C
Cromel COPEL® "L"	GOST R 8.585-2001	-200 to +800 °C
Cromel Alumel®		-270 to +1372 °C
W5Re-W20Re "A1"		-0 to +2500 °C

9.4.2 Linearization	Comment	Measuring range
W5Re-W26Re "C"	ASTM E230M-11: 2011	-0 to +2315 °C
W3Re-W25Re	ASTM E1751M-09: 2009	
Platinel II		-0 to +1395 °C
Customer-specific	This setting only appears if a customer-specific linearization has been entered via the setup program and transferred to the device. ⇨ Chapter 12.4 "Customer-specific linearization"	

Parameter	Comment	Value range (default setting in <b>bold</b> )
9.4.3 Temperature difference	This setting is only available if "thermocouple" or "double thermocouple" has been configured under linearization.	0 to <b>10</b> to 100
9.4.4 Temperature compens.		<b>Internal</b> , fixed value
9.4.5 TC fixed value	Setting for the fixed value	-20 to <b>0</b> to 80 °C
9.4.6 Resistance measuring range	The measuring range can be selected here if "linear" or "customer-specific" has been set for linearization and "resistance/potentiometer" or "RTD temperature probe" has been set as the sensor type.	<b>400</b> , 4000, 10000 Ω
9.4.7 Line resistance	Resistance of probe line (for 2-wire circuit)	<b>0.0</b> to 100 Ω
9.4.8 Sensor factor	Only for RTD temperature probe: For adjusting Pt25 to Pt1000 sensors to a different configured linearization (e.g. Pt100). For example, a Pt100 linearization can be corrected with the sensor factor 0.5 in order to connect a Pt50 sensor.	0.25 to <b>1.00</b> to 10.00

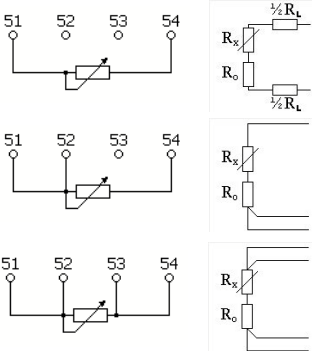
Parameter	Comment	Value range (default setting in <b>bold</b> )
<p><b>9.4.9 Resistance Rx</b></p> 	<p>Parameter appears for the setting "resistance/potentiometer" with 2, 3, or 4-wire circuit. It is dependent on the setting "Resistance measuring range". The maximum value that the variable resistance Rx can adopt must be entered here.</p>	<p><b>0</b> to 400, 4000, or 10000 <math>\Omega</math></p>
<p><b>9.4.10 Line resistance R<sub>L</sub></b></p>	<p>Parameter appears for the setting "resistance/potentiometer" with 2-wire circuit. The sum of the resistance values for the two connecting cables is entered here.</p>	<p><b>0</b> to Rx</p>
<p><b>9.4.11 Resistance R0</b></p>	<p>Parameter appears for the setting "resistance/potentiometer" with 2, 3, or 4-wire circuit. It is possible that the variable resistance cannot adopt the value 0 <math>\Omega</math> as the minimum value (e.g. a mechanical restriction means a potentiometer is unable to reach the minimum possible limit stop). This minimum value should be entered here.</p>	<p><b>0</b> to 400, 4000, or 10000 <math>\Omega</math></p>

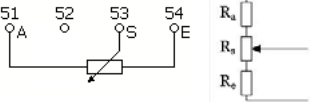
Parameter	Comment	Value range (default setting in <b>bold</b> )
<p><b>9.4.12 Resistance <math>R_a</math>,</b></p> 	<p>Here, the starting resistance of the potentiometer (resistance transmitter) must be entered. I.e. the resistance (between A and S) of the sliding contact at this position (minimum possible limit stop, e.g. left limit stop) must be entered.</p>	<p><b>0</b> to 10000 <math>\Omega</math></p>
<p><b>9.4.13 Resistance <math>R_s</math></b></p>	<p>The resistance value that the sliding contact can cover from the minimum value (minimum possible limit stop, e.g. left limit stop) to the maximum value (maximum possible limit stop, e.g. right limit stop) must be entered here.</p>	
<p><b>9.4.14 Resistance <math>R_e</math></b></p>	<p>Here, the end resistance value of the potentiometer (resistance transmitter) must be entered. I.e. the resistance (between E and S) of the sliding contact at this position (maximum possible limit stop, e.g. right limit stop) must be entered.</p>	
<p><b>9.4.15 Scaling start</b></p>	<p>All sensor types can be scaled here if "linear" has been entered for linearization.</p>	<p>-5000 to <b>0</b> to 50000</p>
<p><b>9.4.16 Scaling end</b></p>		<p>-5000 to <b>100</b> to 50000</p>
<p><b>9.4.17 Offset</b></p>	<p>With the offset, the linearized/scaled measured value can be shifted evenly by the value entered over the entire measuring range.</p>	<p>-5000 to <b>0.0</b> to 50000 <math>^{\circ}\text{C}/^{\circ}\text{F}</math>/ text</p>

Parameter	Comment	Value range (default setting in <b>bold</b> )
<b>9.4.18 Fine adjust. actual start</b>	You can use the fine adjustment to correct the measured values of the analog input. This may become necessary if the scaling and offset do not result in the desired display.  ⇒ Figure in Chapter 5.4 "Signal flow"	-5000 to <b>0.0</b> to 50000
<b>9.4.19 Fine adjust. actual end value</b>		-5000 to <b>0.0</b> to 50000
<b>9.4.20 Fine adjust. target start</b>		-5000 to <b>0.0</b> to 50000
<b>9.4.21 Fine adjust. target end value</b>		-5000 to <b>0.0</b> to 50000
<b>9.4.22 Noise suppression</b>	Equalizes the input signals using the digital input filter.	Yes, <b>No</b>
<b>9.4.23 Filter time constant</b>	<p><b>Time constant of the digital input filter, 2nd order</b></p> <p>If the input signal changes suddenly, approx. 26 % of the change is recorded following a period that corresponds to the filter time constant <math>dF</math> (<math>2 \times dF</math>: approx. 59 %; <math>5 \times dF</math>: approx. 96 %).</p> <p>Value 0 means: filter switched off</p> <p>If the filter time is long:</p> <ul style="list-style-type: none"> <li>- Interfering signals are better absorbed</li> <li>- Measured value display responds more slowly to changes</li> </ul>	0.0 to <b>0.1</b> to 100 sec

## 9.5 Analog output

Parameter	Comment	Value range (default setting in <b>bold</b> )
<b>9.5.1 Signal type</b>	Here, the standard signal for the analog output is set.	<b>4 to 20 mA</b> , 0 to 20 mA 2 to 10 V 0 to 10 V
<b>9.5.2 Output range start</b>	Here, the output range of a temperature, resistance, current, or voltage measured value can be set (restricted).	Measuring range start to <b>0</b> to measuring range end
<b>9.5.3 Output range end</b> ⇒ Chapter 5.4 "Signalfluss" Setting 0 to 120 °C		Measuring range start to <b>100</b> to measuring range end
■ SIL operation		
<b>9.5.4 Scaling start</b> ⇒ Chapter 5.4 "Signalfluss" Setting 6 to 18 mA	At scaling end, the setup program requires a higher value than at scaling start, i.e. in the case of 4 to 20 mA, set a value higher than 4 mA as the start.  Here, the output range set in Chapter 9.5.2 and Chapter 9.5.3 is mapped to the scaling configured for the signal type.	<b>4</b> to 20 mA, (the full range of the signal type is applied per default)
<b>9.5.5 Scaling end</b>	The "Scaling end" value is entered here.	0 to <b>20</b> mA
<b>9.5.6 Output reversion</b>	The signal at the output can be inverted here. For example, for a setting of 0 °C = 0 V and 50 °C = 10 V, through the reversion this becomes 50 °C = 0 V and 0 °C = 10 V at the output	<b>No</b> , Yes

Parameter	Comment	Value range (default setting in <b>bold</b> )
<b>9.5.7 Error signal</b>	If, for the measured value, the value is exceeded, not reached, or a diagnostic error occurs, the current or voltage value set here is output on the analog output as a so-called error signal. ⇒ Chapter 9.5.10 "Behavior when leaving the scaling range"	<b>Negative signaling</b> , positive signaling, replacement value
	For signal type 4 to 20 mA	<b>Low 3.6</b> or high 21.2 mA
	For signal type 0 to 20 mA	<b>Low -0.4</b> or high 21.2 mA
	For signal type 2 to 10 V	<b>Low 1.8</b> or high 10.6 V
	For signal type 0 to 10 V	<b>Low -0.2</b> or high 10.6 V

■ SIL operation

<b>9.5.8 Output simulation</b>	An output current/output voltage can be simulated to test the system that follows. It is also possible to simulate error signals.	<b>OFF</b> ON
<b>9.5.9 Simulation value</b>	The value set here is simulated. The value range depends on the signal type that has been set.	for 0(4) to 20 mA; -0.4(3.6) to 21.2 mA,  for 0(2) to 10 V: -0.2(1.8) to 10.6 V

■ SIL operation

### 9.5.10 Behavior when leaving the scaling range

The standard-signal ranges of the analog output are limited as follows according to the recommendation of NAMUR NE 43:

Signal type	Lower limit	Upper limit
4 to 20 mA	3.6 mA	21.2 mA
0 to 20 mA	-0.4 mA	21.2 mA
2 to 10 V	1.8 V	10.6 V
0 to 10 V	-0.2 V	10.6 V

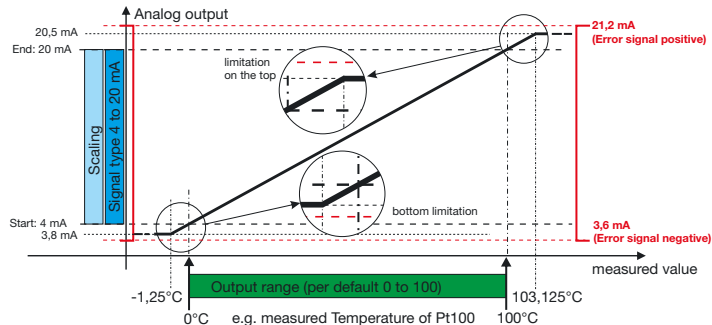

In this example, the measured value from 0 to 100°C is output on the analog output with 4 to 20 mA.



#### Caution

The analog output is **part of the safety function**.



## 9.6 RS485 interface

Parameter	Comment	Value range (default setting in <b>bold</b> )
9.6.1 Baud rate	Protocol: Modbus slave	<b>9600</b> , 19200, 38400, 57600, 115200
9.6.2 Data format	Data bits/stop bits/parity	<b>8/1/no parity</b> , 8/1/odd parity, 8/1/even parity, 8/2/no parity
9.6.3 Device address		<b>1</b> to 254

## 9.7 Service

Parameter	Comment	Value range (default setting in <b>bold</b> )
9.7.1 Minimum measured value	Minimum measured value is displayed	
9.7.2 Maximum measured value	Maximum measured value is displayed	
9.7.3 Min. measured value reset	Minimum drag indicator value is reset to the measured value	<b>No</b> , Yes
9.7.4 Max. measured value reset	Maximum drag indicator value is reset to the measured value	<b>No</b> , Yes

## 10 Device info

### 10.1 Version

The device software version for channel and diagnostics, fabrication number, inspection ID, and the SIL extra code are displayed here.

#### Device software version channel:

#### Device software version diagnostics:

#### Fabrication number:

The first 8 digits are the production order number: 02472588

Digit 9 and 10 manufacturing site Fulda: 01

Digit 11 (second row) device version: 0

Digit 12 and 13 year: **2018**

Digit 14 and 15 calendar week: 11

Digit 16 to 19 consecutive number: 0003

#### Inspection ID:

#### Extra code SIL:

"No" means not present, "Yes" means present.

⇒ Chapter 12.6 "Switching on/switching off the SIL extra code"

#### Hardware version:

Ex

Version	Version	Version	Version
SIL version channel	SIL-Version Diagnostic	Serial No.	Check-ID
348.01.01	348.02.01	0247258801 018110003	05009719
Version	Version		
Type code SIL	Hardware- version		
Yes	EX		

## 10.2 Service

Parameter	Comment	Value range (default setting in <b>bold</b> )
<b>10.2.1 Total operation time</b>	<b>Operating hours counter</b> The counter adds up the operating hours during which the device was connected to the voltage supply. The value cannot be changed and can be used as a measure of how long the device was actually in operation after leaving the factory.	<b>0</b> to 99999 hours
<b>10.2.2 Operation time since last configuration</b>	<b>Operation time since the last change in the configuration level</b> Here, the time during which the device was in operation since the last configuration step is displayed. This also applies for configuration performed via the setup program.	<b>0</b> to 99999 hours

## 10.3 Hardware identification

The extra codes installed in the device are displayed here.

```
Hardware  
recognit.  
Option  
RS485  
Fitted
```

## 11 Technical data

### 11.1 Analog input

#### 11.1.1 RTD temperature probe

Designation	Standard	Measuring range	Measuring accuracy <sup>a</sup>	R <sub>100</sub> /R <sub>0</sub>	ITS
Pt50 2/3-wire circuit 4-wire circuit	GOST 6651-2009 A.2	-200 to +850 °C	±0.5 K ±0.3 K	1.391	90
Pt100 2/3-wire circuit 4-wire circuit	GOST 6651-2009 A.2	-100 to +200 °C -200 to +850 °C -100 to +200 °C -200 to +850 °C	±0.2 K ±0.4 K ±0.15 K ±0.25 K	1.3911	90
Pt100, Pt500, Pt1000 2/3-wire circuit 4-wire circuit	IEC 60751:2008	-100 to +200 °C -200 to +850 °C -100 to +200 °C -200 to +850 °C	±0.2 K ±0.4 K ±0.1 K ±0.2 K	1.3851	90
Ni100, Ni500, Ni1000 2/3-wire circuit 4-wire circuit	DIN 43760:1987-09	-60 to +250 °C -60 to +250 °C	±0.4 K ±0.2 K	1.618	ITPS 68
Ni100 2/3-wire circuit 4-wire circuit	GOST 6651-2009 A.2	-60 to +180 °C -60 to +180 °C	±0.4 K ±0.2 K	1.617	90

Designation	Standard	Measuring range	Measuring accuracy <sup>a</sup>	R <sub>100</sub> /R <sub>0</sub>	ITS
Cu50 2/3-wire circuit 4-wire circuit	GOST 6651-2009 A.2	-180 to +200 °C -180 to +200 °C	±0.5 K ±0.3 K	1.428	90
Cu100 2/3-wire circuit 4-wire circuit	GOST 6651-2009 A.2	-180 to +200 °C -180 to +200 °C	±0.4 K ±0.2 K	1.428	90
Ambient temperature influence		≤ ±0.005 %/K deviation from 22 °C			
Measuring current		< 0.3 mA			
Sensor line resistance		≤ 50 Ω per line for 3- and 4-wire circuit ≤ 100 ohms line resistance for 2-wire circuit			
Lead compensation		Not required for 3-wire or 4-wire circuit. In 2-wire circuits, lead compensation is performed in the software by entering a fixed line resistance.			
Special features		- Can also be programmed in °F - Basic sensor type can be changed with sensor factor (e.g., Pt50 to Pt100)			

a The accuracy specifications refer to the maximum measuring range.

## 11.1.2 Thermocouples

Designation	Standard	Measuring range	Measuring accuracy <sup>b</sup>	ITS
Fe-CuNi "L"	DIN 43710:1985-12	-200 to +900 °C	±0.1 %	68
Fe-CuNi "J"	DIN EN 60584-1:2014	-210 to +1200 °C	±0.1 % from -100 °C	90
Cu-CuNi "U"	DIN 43710:1985-12	-200 to +600 °C	±0.1 % from -100 °C	68
Cu-CuNi "T"	DIN EN 60584-1:2014	-200 to +400 °C	±0.1 % from -150 °C	90
NiCr-Ni "K"	DIN EN 60584-1:2014	-200 to +1300 °C	±0.1 % from -80 °C	90
NiCr-CuNi "E"	DIN EN 60584-1:2014	-200 to +1000 °C	±0.1 % from -80 °C	90
NiCrSi-NiSi "N"	DIN EN 60584-1:2014	-200 to +1300 °C	±0.1 % from -80 °C	90
Pt10Rh-Pt "S"	DIN EN 60584-1:2014	-50 to 1768 °C	±0.15 % from -60 °C	90
Pt13Rh-Pt "R"	DIN EN 60584-1:2014			
Pt30Rh-Pt6Rh "B"	DIN EN 60584-1:2014	-50 to 1820 °C	±0.15 % from 400 °C	90
W5Re-W26Re "C"	ASTM E230M-11	0 to 2315 °C	±0.15 %	90
W5Re-W20Re "A1"	GOST R 8.585-2001	0 to 2500 °C	±0.15 %	90
W3Re-W25Re "D"	ASTM E1751M-09	0 to 2315 °C	±0.25 %	90
Chromel®-COPEL® "L"	GOST R 8.585-2001	-200 to +800 °C	±0.1 % from -80 °C	90
Chromel®-Alumel®	GOST R 8.585-2001	-270 to +1372 °C	±0.1 % from -80 °C	90
PLII (Platinel)	ASTM E1751M-09	0 to 1395 °C	±0.15 %	90

Designation	Standard	Measuring range	Measuring accuracy <sup>b</sup>	ITS
Ambient temperature influence		≤ ±0.005 %/K deviation from 22 °C, plus accuracy of the cold junction		
Measuring range start/end		Freely programmable within the limits in steps of 0.1 °C		
Cold junction		Pt1000 internal; external cold junction temperature		
Cold junction accuracy (internal)		±1 K		
Cold junction temperature (external; fixed value)		-20 to +80 °C, configurable		
Special features		Also configurable in °F		

b The accuracy specifications refer to the maximum measuring range.

### 11.1.3 Standard signals

Designation	Measuring range	Measuring accuracy <sup>c</sup>	Ambient temperature influence
<b>Voltage</b> freely scalable Input resistance $R_{IN} > 500 \text{ k}\Omega$ Input resistance $R_{IN} > 1 \text{ M}\Omega$	DC 0 to 10 V DC 0 to 1 V	±5 mV ±0.05 %	≤ ±0.005 %/K deviation from 22 °C
<b>Current</b> Voltage drop ≤ 2 V, freely scalable	DC 0(4) to 20 mA	±20 μA	≤ ±0.005 %/K deviation from 22 °C
Galvanic isolation	see Chapter 3.5 "Galvanic isolation"		
Special features	Measuring range scaling adjustable		

Limits according to NAMUR recommendation NE 43 in case of deviation under/above measuring range	<b>Signal type 4 to 20 mA</b>
Measurement information M	3.8 to 20.5 mA
Failure information A for deviation below measured value/short circuit ("NAMUR Low")	≤ 3.6 mA
Failure information A for deviation above measured value/probe break ("NAMUR High")	≥ 21 mA

c The accuracy specifications refer to the maximum measuring range.

### 11.1.4 Resistance transmitter

Designation	Measuring range	Measuring accuracy <sup>d</sup>	Ambient temperature influence
Resistance transmitter	≤ 400 Ω	±0.4 Ω	≤ ±0.01 % per K deviation from 22 °C
Resistance transmitter	400 to 4000 Ω	±4 Ω	≤ ±0.01 % per K deviation from 22 °C
Resistance transmitter	4000 to 10000 Ω	±10 Ω	≤ ±0.01 % per K deviation from 22 °C
Connection type	3-wire circuit		
Sensor line resistance	Max. 50 Ω per line		
Resistance values	Freely programmable within the limits in steps of 0.1 Ω		
Special features	Measuring range scaling adjustable		

d The accuracy specifications refer to the maximum measuring range.



### 11.1.5 Resistance/potentiometer

Designation	Measuring range	Measuring accuracy	Ambient temperature influence
Sensor type resistance/potentiometer	Max. 10 k $\Omega$	$\pm 10 \Omega$	$\leq \pm 0.01 \text{ \%}/\text{K}$ deviation from 22 °C
Connection type	Resistance with 2, 3, or 4-wire circuit		
Sensor line resistance	$\leq 50 \Omega$ per line for 3 and 4-wire circuit $\leq 100 \Omega$ line resistance for 2-wire circuit		
Resistance values	Freely programmable within the limits in steps of 0.1 $\Omega$		
Special features	Measuring range scaling adjustable		

### 11.2 Measuring circuit monitoring

Measuring probe	Out of range	Probe/cable break	Probe/cable short circuit
RTD temperature probe	Is detected	Is detected	Is detected
Resistance transmitter	Is detected	Is detected	Is not detected
Thermocouple (single)	Is detected	Is detected	Is not detected
Double thermocouple	Is detected	Is detected	Is detected
Voltage 0 to 10 V 0 to 1 V	Is detected Is detected	Is not detected Is not detected	Is not detected Is not detected

Measuring probe	Out of range	Probe/cable break	Probe/cable short circuit
Current 4 to 20 mA 0 to 20 mA	Is detected Is detected	Is detected Is not detected	Is detected Is not detected

### 11.3 Test voltages

Input and output against voltage supply	
Voltage supply DC 24 V	4260 V

### 11.4 Electrical safety

	Clearances / creepage distances
Mains voltage to electronic components and probes	$\geq 8 \text{ mm}$ / $\geq 4 \text{ mm}$

### 11.5 Analog output

Resolution of D/A converter >15 bit	Load resistance $R_{\text{Load}}$	Accuracy	Burden influence
Voltage DC 0(2) to 10 V Current DC 0(4) to 20 mA	$\geq 500 \Omega$ $\leq 500 \Omega$	$\leq \pm 0.05 \%$ referring to 10 V $\leq \pm 0.05 \%$ referring to 20 mA	$\leq \pm 15 \text{ mV}$ $\leq \pm 0.02 \%/100 \Omega$

### 11.6 Display

Type, resolution	Dot-matrix LCD display with $64 \times 96$ pixels
------------------	---

Configuration	Contrast can be adjusted on device, backlight can be switched off via timeout
---------------	---

## 11.7 Electrical data

Voltage supply	DC 24 V, +10, -15 % SELV or PELV
Power consumption	max. 3 W
Inputs and outputs Conductor cross section	Max. 2.5 mm <sup>2</sup> , wire or stranded wire with ferrule
Electrical safety	According to DIN EN 61010-1 Overvoltage category III, pollution degree 2 Test peak voltage, measurement input to analog output: 1875 V / 50 Hz
Electromagnetic compatibility Interference emission Interference immunity	According to DIN EN 61326-1 Class A - For industrial applications only - Industrial requirements
Sampling rate	500 ms
Input filter	Digital filter, 2nd order; filter time constant can be adjusted from 0 to 100 s

## 11.8 Environmental influences

Operating/storage temperature range	-10 to +70 °C / -20 to +80 °C
Resistance to climatic conditions	≤ 85 % relative humidity, annual average, no condensation

## 11.9 Housing

Site altitude	Maximum 2000 m above sea level
---------------	--------------------------------

Housing type, material	Plastic housing, polycarbonate (use in interiors only)
Flammability class	UL94 V0
Electrical connection	Pluggable screw terminals
Mounting on	Mounting rail 35 mm × 7.5 mm according to DIN IEC 60715
Close mounting	Permitted
Installation position	Vertical
Protection type	IP20 according to DIN EN 60529
Weight with screw terminals	Approx. 200 g

## 11.10 Approvals/approval marks

Approval mark	Test facility	Certificate/certification number	Inspection basis	Valid for
SIL2	TÜV Nord (German Technical Inspection Agency)	SEBS-A.20140509.0933409	EN 61508 1-7	All modules
PL c			EN ISO 13849	
ATEX "i"		TÜV 19 ATEX 244073 X	Directive 2014/34/EU EN 60079-0 EN 60079-11	
ATEX "h"			Directive 2014/34/EU EN 80079-36 EN 80079-37	
ATEX safety device pursuant to "e" and "t"			Directive 2014/34/EU EN 50495	
IECEX "i"		IECEX TUN 19.0005X	IEC 60079-0 IEC 60079-11	
IECEX "h"			ISO 80079-36 ISO 80079-37	

## 12 Setup program





The program and the connecting cable are available as accessories and offer the following possibilities:

- Simple and convenient parameterization and archiving via PC
- Easy parameter duplication for identical types of devices

### 12.1 Minimum hardware and software requirements:

- PC Pentium III or higher
- 200 MB free hard disk space
- CD-ROM drive
- Free USB interface, mouse connection
- Microsoft<sup>1</sup> Windows 7 (32-bit) -> 1 GB RAM
- Microsoft<sup>1</sup> Windows 7 (64-bit) -> 2 GB RAM

### 12.2 Displaying the device software version

- \* Connect the device to the PC using the USB cable
- \* Press the  key
- \* Use  to switch to device info and press 
- \* Press  key and the software version appears.

The software versions of the device and the setup program must be compatible. Only the last two digits may be different, otherwise an error message appears!

The version of the setup program appears under *Info* ⇒ *Info about setup*.

1. Microsoft® is a registered trademark of the Microsoft Corporation

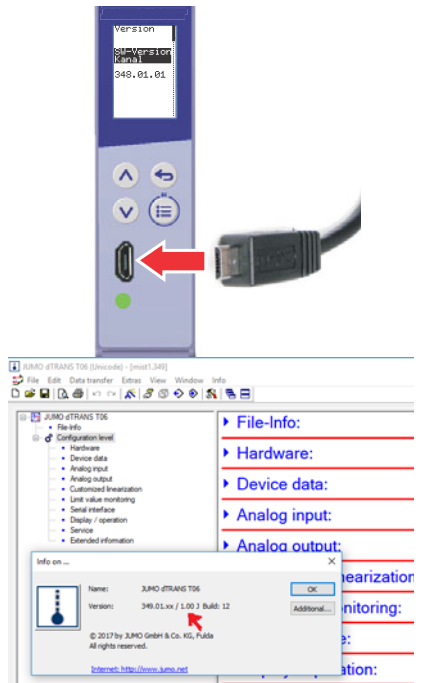

## 12.3 Forgotten the code?

If you forget the code, it can be read out via the USB interface and the setup program.

\* Use *Data transfer*  $\Rightarrow$  from device.

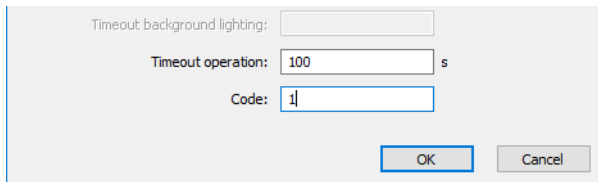

Timeout background lighting:

Timeout operation:  s

Code:

OK Cancel

The read-out code now appears in the setup program in the sub-menu "Display/operation".

It can be kept as it is or changed.

If "0" is set and transferred to the device, the code interrogation is disabled and the configuration level is freely accessible.

## 12.4 Customer-specific linearization

Coefficients (DKD calibration values), formulas, or 40 value pairs (grid points) can be entered in the customer linearization sub-menu.

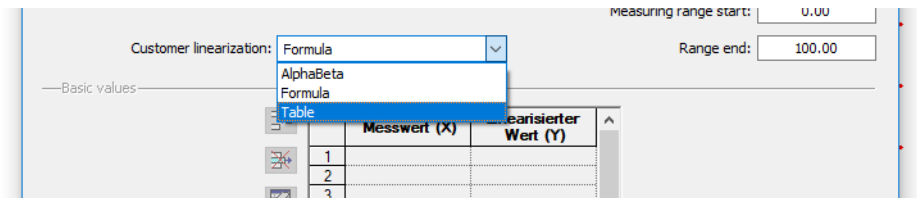

measuring range start:

Range end:

Customer linearization:

- AlphaBeta
- Formula
- Table

Basic values

Messwert (X)	Linearisierter Wert (Y)
1	
2	
3	

## 12.5 Resetting the drag indicator

The drag indicator shows the maximum and minimum measured value. It can be reset with the setup program. The measured value currently shown in the display is set.

On the device, see Chapter 9.7.3 "Min. measured value reset"

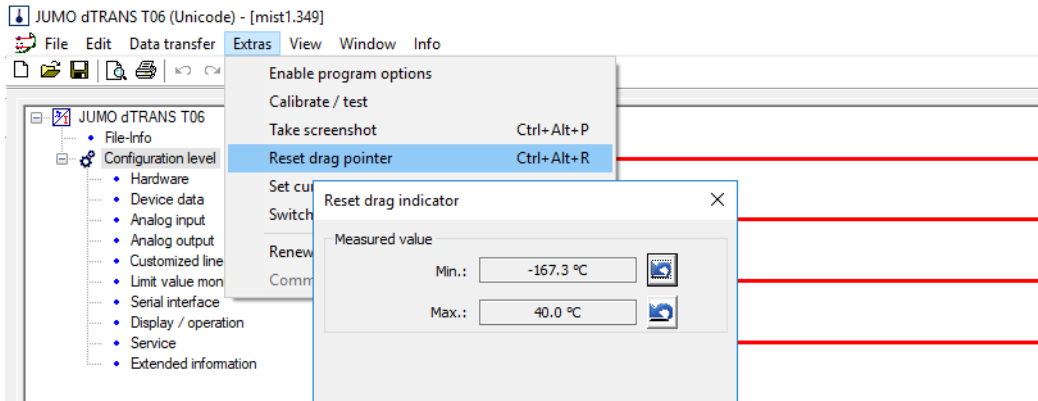



## 12.6 Switching on/switching off the SIL extra code

The restrictions for SIL operation can only be deactivated with the setup program.

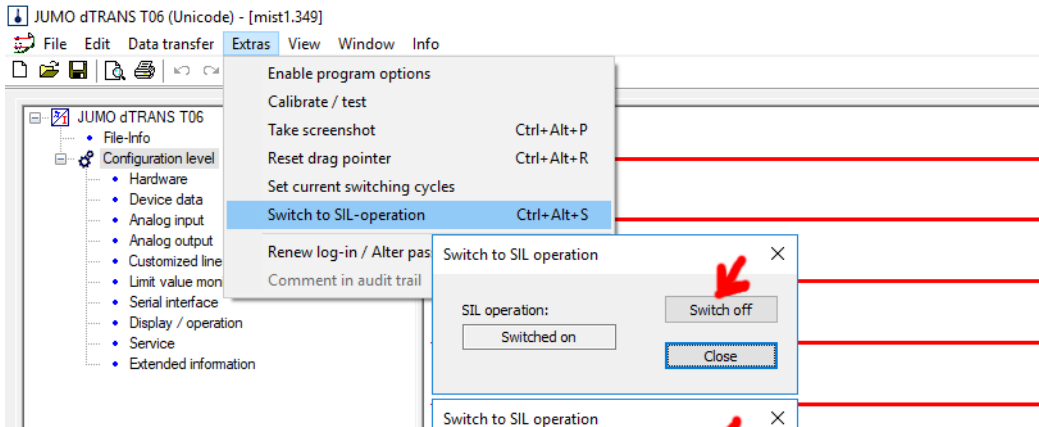

## 12.7 Checking safety-relevant system properties





### Caution

To ensure that all parameters have been correctly transferred, the user must validate the safety function and approach the limit values once the parameters have been transferred via the setup.

## 13 Error messages

### 13.1 Display types

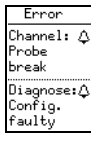
	<p>Measured value flash-</p>	<p>The measured value flashes.</p> <p>The analog output displays the negative limit.</p> <p>* Press the  key for further information.</p>
		<p>Here, the diagnostics channel has detected an error at the analog output, as can also be seen in the table Chapter 13.3 "Diagnostics channel".</p>

## 13.2 Safety channel

Display	Origin	Cause/remedy
Terminal temperature	Internal	Terminal temperature outside the limits or probe faulty.
Reference A/D converter	Internal	Deviation during the reference measurement of the A/D converter / Restart device/return device
Not calibrated	Internal	Channel not calibrated
Configuration	Internal	Configuration data outside the value range. * The message cannot be acknowledged until it is within the admissible range again.
CRC Test Calibr.	Internal	Checksum error of the EEPROM calibration data. Restart device/return device.
CRC Test Config.	Internal	Checksum error of the EEPROM configuration data. Restart device/return device.
CPU Register	Internal	A CPU registry error has occurred. Restart device/return device
RAM defective	Internal	A RAM error has occurred. Restart device/return device.
ROM defective	Internal	A ROM error has occurred. Restart device/return device.
Program sequence	Internal	A program sequence error has occurred. Restart device/return device.

Display	Origin	Cause/remedy
Watchdog	Internal	A watchdog reset has occurred. Restart device/return device.
Voltage supply	Internal	The voltage supply is insufficient. Check voltage supply.
Frequency deviation	Internal	Error of the independent time base. Restart device/return device.
EEPROM defective	Internal	Error during internal communication with the EEPROM. Restart device/return device.
Stack	Internal	Error in the memory area reserved for the stack. Restart device/return device.
A/D conversion	Internal	A program sequence error has occurred. Restart device/return device.
Interrupt	Internal	Interrupt error Restart device/return device.
Limit value	System	The configured limit value has been exceeded or undershot. Check system/adapt limit value

## 13.3 Diagnostics channel

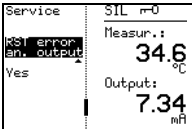

Display	Origin	Cause/remedy
Voltage 3 V	Internal device	Error detected when measuring the 3 V voltage supply Restart device/return device.
Voltage 5 V	Internal device	Error detected when measuring the 5 V voltage supply Restart device/return device.
Signal analog output	Internal device	<p>Analog output signal deviates from the specification of the safety channel. This may be caused by an "open" analog output (without load).</p> <p><b>Note:</b> Error is only reported if the deviation occurs for more than 5 seconds.</p> <p><b>Remedy:</b></p> <ul style="list-style-type: none"> <li>* Check load at analog output</li> <li>* In the configuration level -&gt; Service -&gt; Reset error -&gt; yes</li> </ul> <p>If this error is rectified, the analog output once again delivers valid values.</p> <p>A restart also results in a reset of the error.</p>  <p>The screenshot shows a service menu with the following text: 'Service', 'SIL r0', 'KBI error an. output', 'Measur.: 34.6 °C', 'Output: 7.34 mA', and 'Yes'.</p>
Voltage analog output	Internal device	Error detected when measuring the analog output voltage supply. Restart device/return device.
Software versions	Internal device	The software versions of the safety channel and diagnostics channel do not match. Restart device/return device.

Display	Origin	Cause/remedy
Internal comm.	Internal device	Communication between safety channel and diagnostics channel faulty. Restart device/return device.
Editing procedure	Internal device	An error has occurred during editing. Restart device/return device.
Config. faulty	Internal device	The configuration is faulty * Check configuration
ROM defective	Internal diagnostics	A ROM error has occurred. Restart device/return device.
RAM defective	Internal diagnostics	A RAM error has occurred. Restart device/return device.
Parameter faulty	Internal diagnostics	Parameter faulty * Check configuration
CRC Test RAM	Internal diagnostics	CRC test of configuration in RAM returned an error Restart device/return device.
CRC Test EEPROM	Internal diagnostics	CRC test of configuration in EEPROM returned an error Restart device/return device.
Program sequence	Internal diagnostics	Program sequence faulty. Restart device/return device.
EEPROM access	Internal diagnostics	An error occurred during EEPROM reading/writing. Restart device/return device.
USB communication	Internal diagnostics	Error during communication via USB. Restart device/return device.
RS485 communication	Internal diagnostics	Error during RS485 communication. Restart device/return device.

## 13.4 Measured value recording

Display	Cause/remedy
<<<<<	Underrange / check sensor configuration, check measuring chain
>>>>>	Overrange / check sensor configuration, check measuring chain
- - - - -	Invalid value / restart device, otherwise return device
- - 4 - -	Division by zero / restart device, otherwise return device
+++++	Error relating to terminal temperature or compensation signal / restart device, otherwise return device
<-<-<	Probe short circuit / check sensor configuration, check line for short circuit
>->->	Probe break / check sensor configuration, check line for interruption
-1-0-	No data received from channel / restart device, otherwise return device
*****	Value cannot be displayed, display overrun / restart device, otherwise return device

## 14 What to do, if ...

Description	Cause	Remedy
<p>The following appears in the display:</p> 	<p><b>Setup program transmits data.</b> The safe state is adopted during data transmission (if SIL is active). The data is then exchanged between channel and diagnostics and then the device returns to normal state.</p>	<ul style="list-style-type: none"><li>- Wait until data transmission has finished</li></ul>
<p>The following appears in the display:</p> 	<p>Changes were made in the configuration level that are implausible or that have an impact on the downstream function blocks. This can also cause the LED to light up red. <b>Example:</b> If the sensor type is changed from RTD temperature probe to thermocouple, for example, the linearization of the thermocouple must also be entered so that the following functions can function correctly.</p>	<ul style="list-style-type: none"><li>- Check the settings in the configuration level until the LED lights up green again.</li></ul> <p>⇒ Chapter 5.1 "Anzeige- und Bedienelemente"</p>



Description	Cause	Remedy
<p>If a parameter in this tree structure is changed, the underlying parameters must be checked for correctness and adjusted if necessary.</p>	<div style="display: flex; justify-content: space-around;"> <div style="text-align: center;"> <h3>Analog input</h3> <p>check dependent parameters</p> <pre> graph TD     A[Sensor type] --&gt; B[Linearization]     B --&gt; C[Scaling Start/end (input)]     B --&gt; D[Output range]     B --&gt; E[Limit value]     C --&gt; D     C --&gt; E     F[Measuring range] --&gt; G[Resistors Rx, RO, Ri]             </pre> <p>check resistors</p> </div> <div style="text-align: center;"> <h3>Analog output</h3> <p>check dependent parameters</p> <pre> graph TD     H[Signal type] --&gt; I[Scaling Start/end (output)]     H --&gt; J[Replacement value]     H --&gt; K[Simulation value]             </pre> </div> </div>	
<p>... The backlight is off.</p>	<ul style="list-style-type: none"> <li>- Timeout lighting was activated. The backlight switches off automatically after the set time.</li> </ul>	<ul style="list-style-type: none"> <li>* Press any key or switch off timeout.</li> <li>⇒ Chapter 9.3.5 "Lighting timeout"</li> </ul>
<p>... The LED lights up red</p>	<ul style="list-style-type: none"> <li>- Here, all points that indicate a diagnostic error must be checked.</li> <li>- Check dependent parameters (described in the table above)</li> </ul>	<ul style="list-style-type: none"> <li>* Is the current output wired correctly? The current output will be unable to deliver current if the connected device is "too resistive" or if the wiring is faulty.</li> <li>⇒ Chapter 4.2.2 "Analog output (part of the safety channel)"</li> </ul>

**15 Certificates**

**JUMO GmbH & Co. KG**  
Moritz-Juchheim-Straße 1  
36039 Fulda, Germany

Tel.: +49 661 6003-0  
Fax: +49 661 6003-300

E-Mail: [mail@jumo.net](mailto:mail@jumo.net)  
Internet: [www.jumo.net](http://www.jumo.net)



More than **100 years** of experience

## EU-Konformitätserklärung

EU declaration of conformity / Déclaration UE de conformité

**Dokument-Nr.**

CE 813

Document No. / Document n.°

JUMO GmbH & Co. KG

**Hersteller**

Hersteller / Etabli par

Moritz-Juchheim-Straße 1, 36039 Fulda, Germany

**Anschrift**

Adresse / Adresse

**Produkt**

Product / Produit

**Name**

Name / Nom

JUMO DTRANS T06 EX

**Typ**

Type / Type

707075

**Typenblatt-Nr.**

Data sheet no. / N°

Document

d'identification

707075

**Wir erklären in alleiniger Verantwortung, dass das bezeichnete Produkt die Anforderungen der Europäischen Richtlinien erfüllt.**

*We hereby declare in sole responsibility that the designated product fulfills the requirements of the European Directives.*

*Nous déclarons sous notre seule responsabilité que le produit remplit les Directives Européennes.*

### 1. Richtlinie

Directive / Directive

**Name**

EMC

Name / Nom

**Fundstelle**

2014/30/EU

Reference / Référence

**Bemerkung**

Comment / Remarque

**Datum der Erstanbringung des CE-Zeichens auf dem Produkt** 2020

Date of first application of the CE mark to the product / Date

de première application du sigle sur le produit

Dokument-Nr.  
Document No. / Document n.°

CE 813

EU-Konformitätserklärung

Seite: 1 von 4

**JUMO GmbH & Co. KG**  
 Metz-Luchters, Straße 1 Tel.: +49 661 0003300 E-Mail: metz@jumo.net  
 30039 Fulda, Germany Fax: +49 661 0003300 Internet: www.jumo.net



More than **certificates** & **specifications**

### Angewendete Normen/Spezifikationen

Standards/Specifications applied / Normes/Spécifications appliquées

<b>Fundstelle</b> <i>Reference / Référence</i>	<b>Ausgabe</b> <i>Edition / Edition</i>	<b>Bemerkung</b> <i>Comment / Remarque</i>
EN 60730-1	2016	The edition 2011 is met for presumption of conformity
EN 60730-2-9	2019+A1:2019	The edition 2010 is met for presumption of conformity
EN 61326-1	2013	

### Gültig für Typ

Valid for Type / Valable pour le type  
 707075L...

### 2. Richtlinie

Directive / Directive

#### Name

ATEX

#### Name / Nom

#### Fundstelle

2014/34/EU

#### Referenz / Référence

#### Bemerkung

Mod. B+D

Comment / Remarque

#### Datum der Erstanbringung des CE-Zeichens

2020

#### auf dem Produkt

Date of first application of the CE mark to the product / Date

de /ère application du sigle sur le produit

### Gültig für Typ

Valid for Type / Valable pour le type  
 707075L...

Dokument-Nr.  
 Document No. / Document n°

CE 813

EU-Konformitätsklärung

Seite 2 von 4



## 2.1 EU-Baumusterprüfbescheinigung

*EU type examination certificate / Certificat d'examen de type UE*

<b>Fundstelle</b> <i>Reference / Référence</i>	TÜV 19 ATEX 244073 X Ausgabe 00
<b>Notifizierte Stelle</b> <i>Notified Body / Organisme notifié</i>	TÜV NORD CERT GmbH
<b>Kennnummer</b> <i>Identification no. / N° d'identification</i>	0044

## Angewendete Normen/Spezifikationen

*Standards/Specifications applied / Normes/Spécifications appliquées*

<b>Fundstelle</b> <i>Reference / Référence</i>	<b>Ausgabe</b> <i>Edition / Edition</i>	<b>Bemerkung</b> <i>Comment / Remarque</i>
EN 60079-0	2018	
EN 60079-11	2012	
EN 80079-36	2016	
EN 80079-37	2016	
EN 50495	2010	

## Anerkannte Qualitätssicherungssysteme der Produktion

*Recognized quality assurance systems of production / Systèmes de qualité reconnus de production*

<b>Notifizierte Stelle</b> <i>Notified Body / Organisme notifié</i>	<b>Kennnummer</b> <i>Identification no. / N° d'identification</i>
TÜV NORD CERT GmbH	0044

## 3. Richtlinie

*Directive / Directive*

**Name**

RoHS

*Name / Nom*

**Fundstelle**

2011/65/UE

*Reference / Référence*

**Bemerkung**

*Comment / Remarque*

**Datum der Erstanbringung des CE-Zeichens** 2020

**auf dem Produkt**

*Date of first application of the CE mark to the product / Date de 1<sup>ère</sup> application du sigle sur le produit*

Dokument-Nr.:  
Document No. / Document n°:

CE 813

EU-Konformitätsklärung

Seite: 3 von 4

**JUMO GmbH & Co. KG**

Max-Planck-Strasse 1 Tel. +49 661 8003-0  
36039 Fulda, Germany Fax. +49 661 8003-500

E-Mail: [ma@jumo.net](mailto:ma@jumo.net)  
Internet: [www.jumo.net](http://www.jumo.net)



More than **100 years** of experience

### Angewendete Normenspezifikationen

Standards/Specifications applied / Normes/Specifications appliquées

#### Fundstelle

Reference / Référence

**Ausgabe**  
Edition / Edition

**Bemerkung**  
Comment / Remarque

VDK Umweltspezifische Aspekte  
bei der Produktentwicklung und  
-gestaltung VI

### Gültig für Typ

Valid for Type / Valable pour le type  
707075/...

### Aussteller

Issued by / Émis par

JUMO GmbH & Co. KG

### Ort, Datum

Place, date / Lieu, date

Fulda, 2020-05-26

### Rechtsverbindliche Unterschriften

Legally binding signatures /

Signatures juridiquement valables

Bereichsleiter Globaler Vertrieb

ppa. Rainer Riedl

Qualitätsbeauftragter und Leiter Qualitätswesen

I. V. Harald Giegler

Dokument-Nr.  
Document No. / Document n°

CE 813

EU-Konformitätsklärung

Seite: 4 von 4



Devidate  
 Dienstleistungsgesellschaft  
 D-ZE-11074-01-00

# Certificate

No. SEBS-A-114632/18 V1.0

TÜV NORD Systems GmbH & Co. KG hereby certifies to

**JUMO GmbH & Co. KG**

Moritz-Juchheim-Strasse 1  
 36039 Fulda

that the safety related temperature transmitter  
**JUMO DTRANS T06 Ex (Type 707075)**

is capable for safety related applications and meet the requirements listed in the following standards.

- DIN EN 61508-1/-2/-3: 2011, SIL 2 (HFT = 0) and SIL 3 (HFT ≥ 1)
- DIN EN ISO 13849-1: 2016, PL c (Cat 2, HFT = 0) and PL d (Cat. 3, HFT = 1)
- DIN EN ISO 13849-2: 2013
- DIN EN 60730-2-9: 2011

Certification program: Leittechnik (SEB-ZE-SECERT-VA-30-20, Rev. 5.1 / 04.19)

The certification is based on the report  
 No. SEBS-A-114632/18TB in the valid  
 version.

This certificate entitles the holder to use  
 the pictured Safety Approved mark.

Expiry date: 2025-04-23  
 Reference No.: 8115526111

Hamburg, 2020-04-23

*B. Puff*  
 Bianca Puff



Certification Body: SECERT  
 TÜV NORD Systems GmbH & Co. KG  
 Gotha-Bühnenstraße 31, 22625 Hamburg, Germany



- Translation**  
**EU-Type Examination Certificate**
- (1) **Equipment and protective systems**  
Intended for use in potentially explosive atmospheres, Directive 2014/34/EU
- (2) **Certificate Number** TÜV 19 ATEX 244073 X **Issue:** 00
- (3) **for the product:** Temperature transmitter JUMO dTRANS T06 Ex type 707075 / a-bb-ccc
- (4) **of the manufacturer:** JUMO GmbH & Co KG  
Mortiz-Luchheim-Strasse 1, 36039 Fulda, Germany
- (5) **Address:** 8003005500
- (6) **Order number:** 2020-05-07
- (7) **Date of issue:** 2020-05-07
- (8) **EU-Type Examination Certificate** and the documents therein referred to.
- (9) **The design of this product and any acceptable variation thereto are specified in the schedule to this EU-Type Examination Certificate and the documents therein referred to.**
- (10) **The TÜV NORD CERT GmbH, Notified Body No. 0044, in accordance with Article 17 of the Directive 2014/34/EU of the European Parliament and the Council of 26 February 2014, certifies that this product has been found to comply with the Essential Health and Safety Requirements relating to the design and construction of products intended for use in potentially explosive atmospheres given in Annex II to the Directive.**  
The examination and test results are recorded in the confidential ATEX Assessment Report No. 19 203 244073.
- (11) **Compliance with the Essential Health and Safety Requirements has been assured by compliance with:**  
EN IEC 60079-0:2018 EN ISO 80079-36:2016 EN 50495:2010  
EN 60079-1:2012 EN ISO 80079-37:2016
- (12) **except in respect of those requirements listed at item 18 of the schedule.**  
If the sign "X" is placed after the certificate number, it indicates that the product is subject to the Specific Conditions for Use specified in the schedule to this certificate.
- (13) **This EU-Type Examination Certificate relates only to the design, and construction of the specified product. Further requirements of the Directive apply to the manufacturing process and supply of this equipment. These are not covered by this certificate.**
- (14) **The marking of the product shall include the following:**

II (1) G [Ex Ia Ga] IIC or II (1) D [Ex Ia Da] IIIC or  
II (1) G [Ex h Ga] IIC or II (1) D [Ex h Da] IIIC or  
II (2) G [Ex eb Gb] IIC or II (1) D [Ex Ia Da] IIIC or II (2) D [Ex tb Db] IIIC

See Specific Conditions for Use

TÜV NORD CERT GmbH, Langemannstraße 20, 45141 Essen, notified by the central office of the countries for safety engineering (ZLS), Ident. Nr. 0044, legal successor of the TÜV NORD CERT GmbH & Co. KG Ident. Nr. 0032

The head of the notified body

Röder

Hanover office, Am TÜV 1, 30519 Hanover, Tel. +49 511 998-61455, Fax +49 511 998-61590

## 15.3 ATEX

This certificate may only be reproduced without any change, schedule included.  
Examples or changes shall be allowed by the TÜV NORD CERT GmbH



### (13) SCHEDULE

(14) EU-Type Examination Certificate No. TÜV 19 ATEX 244073 X issue 00

#### (15) Description of product:

The temperature transmitter JUMO dTRANS T06 Ex, type 707075 / a-bb-ccc is used for temperature measurement and temperature monitoring by means of resistance thermometers or thermocouples. It is designed for mounting on a carrier rail outside the hazardous area. The temperature limiter and the monitoring unit are used for equipment in hazardous area in protection type Increased Safety Ex "e" [Ex eb] or for Equipment dust ignition protection by enclosure "I" [Ex Ib].  
The intrinsically safe sensor circuit is safely galvanically isolated from the non-intrinsically safe circuits up to a voltage of 375 V.

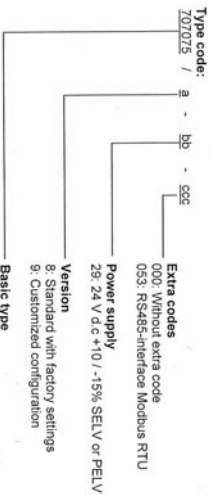

#### Electrical data:

Power supply (Terminals X401: L1\_N, L+, L-)  
Only for the connection to a non-intrinsically safe circuit with a safety-related maximum voltage of:

$$U_{\text{p}} = 24 \text{ V DC } +10 / -15\% \text{ SELV oder PELV}$$

$$U_{\text{m}} = 250 \text{ V}$$

Analogue output (Terminals X201: 41\_42\_43\_44)  
Only for the connection to a non-intrinsically safe circuit with a safety-related maximum voltage of:

$$U_{\text{m}} = 250 \text{ V}$$

RS485 circuit (Terminals X601: 31\_32\_33\_34)  
Only for the connection to a non-intrinsically safe circuit with a safety-related maximum voltage of:

$$U_{\text{m}} = 250 \text{ V}$$

USB Stromkreise (Terminals X303: 1\_2\_3\_4\_5)  
Only for the connection to a non-intrinsically safe circuit with a safety-related maximum voltage of:

$$U_{\text{m}} = 250 \text{ V}$$

**Schedule to EU-Type Examination Certificate No. TÜV 19 ATEX 244073 X Issue 00**

Sensor circuit  
(Terminals X101: 51\_52\_53\_54)  
In type of protection intrinsic safety Ex Ia IIC resp. Ex Ia IIIC  
Maximum values:

$$U_0 = 6 \text{ V}$$

$$I_0 = 13,3 \text{ mA}$$

$$P_0 = 19,9 \text{ mW}$$

Characteristic line: linear  
The effective internal capacitance  $C_i = 72,6 \text{ nF}$   
The effective internal inductance  $L_i$  is negligibly small.

The maximum permissible values for the external inductance  $L_e$  and the external capacitance  $C_e$  have to be taken from the following table:

Ex Ia IIC	$L_e$ [mH]	100	50	20	10	0,2	0,02
	$C_e$ [ $\mu$ F]	0,62	0,82	1,12	1,22	3,32	7,32
Ex Ia IIIC	$L_e$ [mH]	100	50	20	10	0,2	0,02
	$C_e$ [ $\mu$ F]	9,32	10,32	11,32	12,32	30,32	79,32

The values of the table below are only applicable, if the internal inductance  $L_i$  (without the cable) or the internal capacitance  $C_i$  (without the cable) of the connected device is  $\leq 1\%$  of the below specified values.

If  $L_i$  (without the cable) and  $C_i$  (without the cable) of the connected device are  $> 1\%$  of the specified values, the specified values of  $L_e$  shall be reduced to 50 %.

The reduced capacitance of the external circuit (including cable) shall not exceed 1  $\mu$ F for group IIIC and 600 nF for group IIC.

Ex Ia	IIC	IIIC
Maximum permissible external inductance	0,2 H	0,8 H
Maximum permissible external capacitance	39,32 $\mu$ F	999,32 $\mu$ F

**Thermal data:**

Permissible ambient temperature range  $-10^\circ\text{C} \leq T_a \leq +70^\circ\text{C}$

- (16) Drawings and documents are listed in the ATEX Assessment Report No. 19 203 244073

- (17) Specific Conditions for Use

For applications that require EPL Ga or EPL Da devices, the measurement signal transmitter must be used redundantly (HFT > 0).

Only for applications that require EPL Gb or EPL Db devices, the measurement signal transmitter is used as single-channel (HFT = 0).

This refers to equipment which does not provide an ignition source in fault-free operation, but has no fault tolerance with regard to ignition protection.

For alternative concepts / applications, the requirements / options according to EN ISO 80079-37 resp. EN 50495 have to be taken into account.

- (18) Essential Health and Safety Requirements  
No additional ones

- End of Certificate -



## IECEX Certificate of Conformity

INTERNATIONAL ELECTROTECHNICAL COMMISSION  
IEC Certification System for Explosive Atmospheres

for rules and details of the IECEx Scheme visit [www.iecex.com](http://www.iecex.com)

Certificate No.: **IECEX TUN 19.0005X**

Page 1 of 3

Certificate history:

Status:

**Current**

Issue No: 0

Date of Issue:

2020-05-11

Applicant:

**JUMO GmbH & Co. KG**  
Moritz-Juchheim-Strasse 1  
36039 Fulda  
Germany

Equipment:

**Temperature transmitter**

Optional accessory:

JUMO dTRANS T06 Ex type 707075 / a-bb-ccc

Type of Protection:

**Intrinsic safety "a" (IEC 60079-11: 2011 ) Control of ignition sources "p" (ISO 80079-37: 2016 )**

Marking:

[E]a Gaj IIC or [E]a DaJ IIC or  
[E]n Gaj IIC or [E]n DaJ IIC

Approved for issue on behalf of the IECEx  
Certification Body:

**Christian Roder**

Position:

**Head of the IECEx Certification Body**

Signature:  
(for printed version)

Date:

1. This certificate and schedule may only be reproduced in full.
2. This certificate is not transferable and remains the property of the issuing body.
3. The Status and authenticity of this certificate may be verified by visiting [www.iecex.com](http://www.iecex.com) or use of this QR Code.



Certificate issued by:

**TÜV NORD CERT GmbH**  
Hannover Office  
Am TÜV 1, 30559 Hannover  
Germany





## IECEX Certificate of Conformity

Certificate No.: **IECEX-TUN 19.0005X**

Page 2 of 3

Date of Issue: **2020-05-11**

Issue No: 0

Manufacturer: **JUMO GmbH & Co KG**  
Mornitz-Juchhem-Strasse 1, 36039 Fulda  
Germany

Additional  
manufacturing  
locations:

This certificate is issued as verification that a sample(s), representative of production, was assessed and tested and found to comply with the IEC Standard listed below and that the manufacturer's quality system, relating to the Ex products covered by this certificate, was assessed and found to comply with the IECEx Quality system requirements. This certificate is granted subject to the conditions as set out in IECEx Scheme Rules, IECEx 02 and Operational Documents as amended

**STANDARDS:**  
The equipment and any acceptable variations to it specified in the schedule of this certificate and the identified documents, was found to comply with the following standards

IEC 60076-0:2017 Explosive atmospheres - Part 0: Equipment - General requirements  
Edition: 7.0

IEC 60079-11:2011 Explosive atmospheres - Part 11: Equipment protection by intrinsic safety "r"  
Edition: 6.0

ISO 90079-36:2016 Explosive atmospheres - Part 36: Non-electrical equipment for explosive atmospheres - Basic methods and  
Edition: 1.0 requirements

ISO 90079-37:2016 Explosive atmospheres - Part 37: Non-electrical equipment for explosive atmospheres - Non-electrical type of  
Edition: 1.0 protection constructional safety "c", control of ignition source "n", liquid immersion "k"

This Certificate **does not** indicate compliance with safety and performance requirements other than those expressly included in the Standards listed above.

**TEST & ASSESSMENT REPORTS:**

A sample(s) of the equipment listed has successfully met the examination and test requirements as recorded in:

Test Report:

DEFUNEXTR19.0007/00

Quality Assessment Report:

DEFUNQAR13.0005/06



## IECEX Certificate of Conformity

Certificate No.: **IECEX-TUN 19.0005X**

Page 3 of 3

Date of Issue: 2020-05-11

Issue No: 0

### **EQUIPMENT:**

Equipment and systems covered by this Certificate are as follows:

### **Description of product:**

The temperature transmitter JUMO dTRANS T06 Ex, type 707075 / a-bb-ccc is used for temperature measurement and temperature monitoring by means of resistance thermometers or thermocouples. It is designed for mounting on a carrier rail outside the hazardous area.

The intrinsically safe sensor circuit is safely galvanically isolated from the non-intrinsically safe circuits up to a voltage of 375 V.

### **Type code and Electrical data:**

See attachment to IECEX TUN 19.0005

### **Thermal data:**

Permissible ambient temperature range  $-10\text{ }^{\circ}\text{C} \leq T_a \leq +70\text{ }^{\circ}\text{C}$

### **SPECIFIC CONDITIONS OF USE: YES as shown below:**

For applications that require EPL Ga or EPL Da devices, the measurement signal transmitter must be used redundantly (HFT > 0).

Only for applications that require EPL Gb or EPL Db devices, the measurement signal transmitter is used as single-channel (HFT = 0).

This refers to equipment which does not provide an ignition source in fault-free operation, but has no fault tolerance with regard to ignition protection.

For alternative concepts / applications, the requirements / options according ISO 80079-37 have to be taken into account.

### **Annex:**

[Attachment to IECEX TUN 19.0005X issue 0.pdf](#)

TÜV NORD CERT GmbH  
Hannover Office  
Am TÜV 1  
30519 Hannover  
Germany



Page 1 of 2  
Attachment to IECEx TUN 19.0005X Issue No.: 0

**Product:**

**Subject and Type:**  
Temperature transmitter JUMO dTRANS T06 Ex type 707075 / a-bb-ccc

**Description:**

The temperature transmitter JUMO dTRANS T06 Ex type 707075 / a-bb-ccc is used for temperature measurement and temperature monitoring by means of resistance thermometers or thermocouples. It is designed for mounting on a carrier rail outside the hazardous area. The intrinsically safe sensor circuit is safely galvanically isolated from the non-intrinsically safe circuits up to a voltage of 375 V.

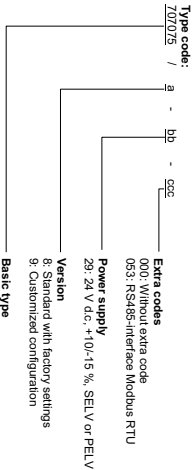

**Electrical data:**

**Power supply**  
(Terminals X401: L1, N, L+, L-)

Only for the connection to a non-intrinsically safe circuit with a safety-related maximum voltage of:

$U_m = 24 \text{ V d.c. } +10/-15 \%, \text{ SELV or PELV}$   
 $U_m = 250 \text{ V}$

**Analogue output**  
(Terminals X201: 41\_42\_43\_44)

Only for the connection to a non-intrinsically safe circuit with a safety-related maximum voltage of:

$U_m = 250 \text{ V}$

**RS485 circuit**  
(Terminals X601: 31\_32\_33\_34)

Only for the connection to a non-intrinsically safe circuit with a safety-related maximum voltage of:

$U_m = 250 \text{ V}$

**USB Stromkreis**  
(Terminals X303: 1\_2\_3\_4\_5)

Only for the connection to a non-intrinsically safe circuit with a safety-related maximum voltage of:

$U_m = 250 \text{ V}$

Sensor circuit  
(Terminals X101: 51\_52\_53\_54)

In type of protection intrinsic safety Ex Ia IIC resp. Ex Ia IIIC  
Maximum values:

$U_0 = 6 \text{ V}$

$I_0 = 13.3 \text{ mA}$

$P_0 = 19.9 \text{ mW}$

Characteristic line: linear

The effective internal capacitance  $C_0 = 680 \text{ nF}$

The effective internal inductance  $L_0$  is negligibly small.

The maximum permissible values for the external inductance  $L_0$  and the external capacitance  $C_0$  have to be taken from the following table:

Ex Ia IIC	$L_0$ [mH]	100	50	20	10	0.2	0.02
	$C_0$ [µF]	0.62	0.82	1.12	1.22	3.32	7.32
Ex Ia IIIC	$L_0$ [mH]	100	50	20	10	0.2	0.02
	$C_0$ [µF]	9.32	10.32	11.32	12.32	30.32	79.32

The values of the table below are only applicable, if the internal inductance  $L_0$  (without the cable) or the internal capacitance  $C_0$  (without the cable) of the connected device is  $\leq 1\%$  of the below specified values. If  $L_0$  (without the cable) and  $C_0$  (without the cable) of the connected device are  $> 1\%$  of the specified values, the specified values of  $L_0$  shall be reduced to 50 %.

The reduced capacitance of the external circuit (including cable) shall not exceed 1 µF for group IIIC and 500 nF for group IIC.

Ex Ia	IIC	IIIC
Maximum permissible external inductance	0.2 H	0.8 H
Maximum permissible external capacitance	39.32 µF	999.32 µF

**Thermal data:**

Permissible ambient temperature range

$-10^\circ\text{C} \leq T_a \leq +70^\circ\text{C}$

**Specific Conditions of Use:**

For applications that require EPL Ga or EPL Da devices, the measurement signal transmitter must be used redundantly ( $HFT > 0$ ).

Only for applications that require EPL Gb or EPL Db devices, the measurement signal transmitter is used as single-channel ( $HFT = 0$ ).

This refers to equipment which does not provide an ignition source in fault-free operation, but has no fault tolerance with regard to ignition protection.

For alternative concepts / applications, the requirements / options according ISO 90079-37 have to be taken into account.

## 15.5 China RoHS

						
产品组别 Productgroup: 707070, 707071, 707075	产品中有害物质的名称及含量 China EEP Hazardous Substances Information					
部件名称 Component Name						
	铅 ( Pb )	汞 ( Hg )	镉 ( Cd )	六价铬 ( Cr(VI) )	多溴联苯 ( PBB )	多溴二苯醚 ( PBDE )
外壳 Housing (Gehäuse)	○	○	○	○	○	○
过程连接 Process connection (Prozessanschluss)	○	○	○	○	○	○
螺母 Nuts (Mutter)	○	○	○	○	○	○
螺栓 Screw (Schraube)	○	○	○	○	○	○
<p>本表格依据SJ/T 11364的规定编制。          This table is prepared in accordance with the provisions SJ/T 11364.          ○ : 表示该有害物质在该部件所有均质材料中的含量均在GB/T 26572规定的限量要求以下。          Indicate the hazardous substances in all homogeneous materials' for the part is below the limit of the GB/T 26572.</p> <p>× : 表示该有害物质至少在该部件的某一均质材料中的含量超出GB/T 26572规定的限量要求。          Indicate the hazardous substances in at least one homogeneous materials' of the part is exceeded the limit of the GB/T 26572.</p>						











**JUMO GmbH & Co. KG**

Street address:  
Mortiz-Juchheim-Straße 1  
36039 Fulda, Germany  
Delivery address:  
Mackenrodtstraße 14  
36039 Fulda, Germany  
Postal address:  
36035 Fulda, Germany  
Phone: +49 661 6003-0  
Fax: +49 661 6003-607  
Email: [mail@jumo.net](mailto:mail@jumo.net)  
Internet: [www.jumo.net](http://www.jumo.net)

**JUMO Instrument Co. Ltd.**

JUMO House  
Temple Bank, Riverway  
Harlow, Essex, CM20 2DY, UK  
Phone: +44 1279 63 55 33  
Fax: +44 1279 62 50 29  
Email: [sales@jumo.co.uk](mailto:sales@jumo.co.uk)  
Internet: [www.jumo.co.uk](http://www.jumo.co.uk)

**JUMO Process Control, Inc.**

6733 Myers Road  
East Syracuse, NY 13057, USA  
Phone: +1 315 437 5866  
Fax: +1 315 437 5860  
Email: [info.us@jumo.net](mailto:info.us@jumo.net)  
Internet: [www.jumousa.com](http://www.jumousa.com)

