

# LPN-DP (Rev 1) Differential Pressure Transmitters.



## Installation Guide.

---

# LPN-DP (Rev 1) Differential Pressure Transmitters.

Programmable Differential Pressure Input to 4~20mA Loop Powered Output Transmitters.

## Features.

- Very Low Pressure Resolution.
- Wide range selection.
- Integral Display.
- Stable Processor Technology.
- Temperature Compensation.
- IP67 Enclosure.
- Fast Response Time.
- High Accuracy & Linearity.
- Compact Size.
- Reverse Polarity Protection.
- Low Cost.
- Easy to Install.



## Description.

The LPN-DP (Rev 1) Series Differential Pressure Transmitters provide a very cost effective solution for pressure applications that require high accuracy over very low operating pressure ranges. The sensor is a solid state device and hence offers reliability and long life. The series is designed for use with non-corrosive, non-ionic working fluids such as air, dry gases and the like.

The LPN-DP (Rev 1) can be used to measure bipolar differential, gauge pressure or vacuum.

## Ordering Information.

|                            |   |                              |
|----------------------------|---|------------------------------|
| <b>Model:</b> LPN-DP-100mm | Differential Range within $\pm 10$ to $\pm 100$ mm W.G.   | Factory set to 0~100mm W.G.  |
| LPN-DP-1000mm              | Differential Range within $\pm 100$ to $\pm 1000$ mm W.G. | Factory set to 0~1000mm W.G. |
| LPN-DP-100kPa              | Differential Range within $\pm 10$ to $\pm 100$ kPa.      | Factory set to 0~100kPa.     |

## Typical Applications.

- HVAC monitoring of:
  - ◊ Filter Differential Pressures.
  - ◊ Fan Static Pressures.
  - ◊ Clean Room Pressures.
  - ◊ Variable Air Volume Systems.
  - ◊ Velocity Pressures.
- Analytical Instruments.
- Dry Non-Corrosive Gases.
- Leak Detection.
- General Automation.

**Product Liability.** This information describes our products. It does not constitute guaranteed properties and is not intended to affirm the suitability of a product for a particular application. Due to on-going research and development, designs, specifications, and documentation are subject to change without notification. Regrettably, omissions and exceptions cannot be completely ruled out. No liability will be accepted for errors, omissions or amendments to this specification. Technical data are always specified by their average values and are based on Standard Calibration Units at 25°C, unless otherwise specified. Each product is subject to the 'Conditions of Sale'.

**Warning:** These products are not designed for use in, and should not be used for patient connected applications. In any critical installation an independent fail-safe back-up system must always be implemented.

## LPN-DP (Rev 1) Specifications.

|                                      |  |
|--------------------------------------|--|
| Output                               | 2 Wire 4~20mA (Loop Powered).  |
| Power Supply                         | 8~33Vdc (Loop Powered).  |
| Maximum Output Current               | 30mA.  |
| Supply Voltage Sensitivity           | <math>\pm 0.01\%/V</math> FSO.                                       |
| Output Load Resistance               | 800W @ 24Vdc (50W/V above 8Vdc).                                     |
| Pressure Fittings                    | Hi / Lo Pressure Connections by 4mm 'Push-fit'.                      |
| Combined Linearity & Hysteresis      | $\pm 0.2\%$ FSO.   |
| Temperature Drift                    | $\pm 0.02\%/C$ FSO (0~50°C).   |
| Repeatability                        | $\pm 0.2\%$ FSO.   |
| Long Term Stability of Offset & Span | $\pm 0.5\%$ FSO.   |
| Compensated Temperature Range        | 0~50°C.  |
| Operating Temperature Range          | 0~70°C.  |
| Maximum Fluid Temperature Range      | -40~85°C.  |
| Humidity Limits                      | 0~90%RH Max. Non-condensing.   |
| Corrosion Proofed                    | Circuit Boards and Components by Isonel 642.                         |
| Enclosure Type                       | Polycarbonate.   |
| Enclosure Rating                     | IP66 rated, RoHS Compliant, UL 94 HB Flammability Rating.            |
| Enclosure Dimensions                 | L=115mm, W=66mm, H=41mm (Length including mounting flanges = 145mm). |

## LPN-DP (Rev 1) Dimensions.

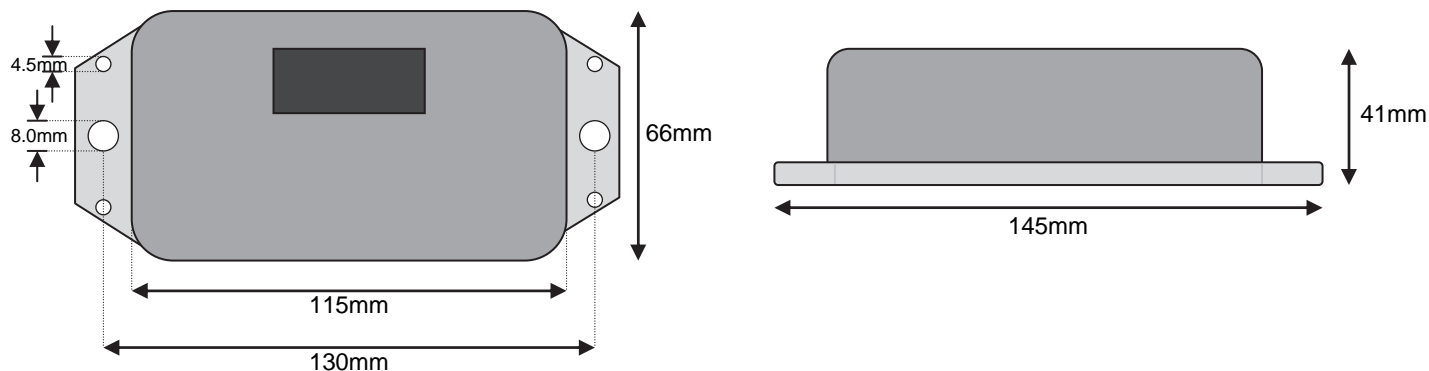

## LPN-DP (Rev 1) Connection Diagram - 4~20mA.

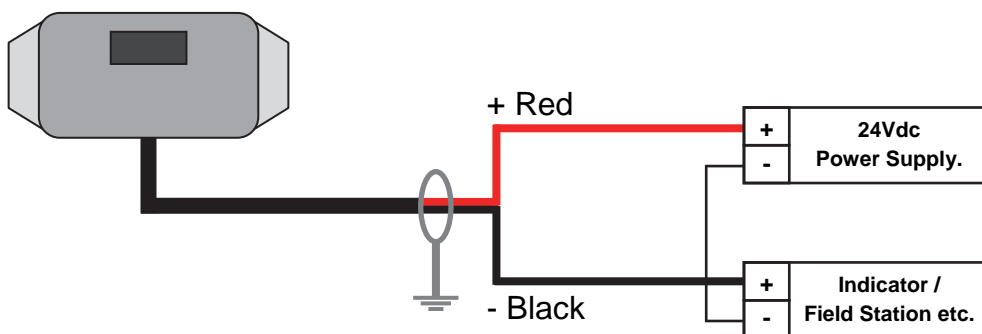

## Maximum Load Vs Power Supply.

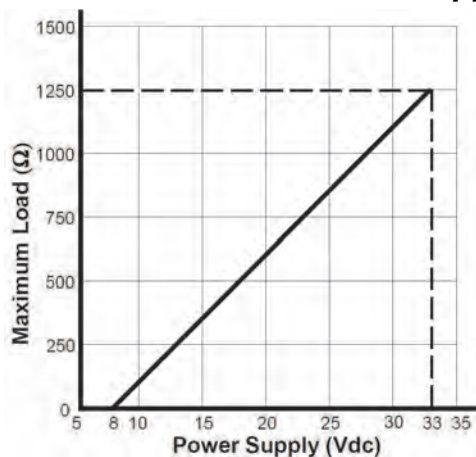

## **The Proper Installation & Maintenance of LPN-DP (Rev 1).**

All power and signals must be de-energised before connecting any wiring.

### **MOUNTING.**

- 1) Do not subject to vibration or excess temperature or humidity variations.
- 2) Avoid mounting next to or in cabinets with power control equipment.
- 3) To maintain compliance with the EMC Directives the LPN-DP (Rev 1) is to be mounted in a fully enclosed steel cabinet. The cabinet must be properly earthed, with appropriate input / output entry points and cabling.

### **WIRING.**

- 1) All cables should be good quality overall screened INSTRUMENTATION CABLE with the screen earthed at one end only.
- 2) Signal Cables should be laid a minimum distance of 300mm from any power cables.
- 3) For 2 wire current loops Austral Standard Cables B5102ES or similar is recommended. For three wire transmitters and RTD's Austral Standard Cables B5103ES or similar is recommended.
- 4) It is recommended that you do not ground current loops and use power supplies with ungrounded outputs.
- 5) Lightning arrestors should be used when there is a danger from this source.
- 6) Refer to diagrams for connection information.

### **PRESSURE CONNECTIONS.**

- 1) Use 4mm OD tubing. (e.g. U-Flex PU2.5 x 4mm.)
- 2) Push the tube into the pneumatic bulkhead fitting as far as it will go. (approx. 12mm.)
- 3) To seal the tube ensure the small olive in the fitting is pulled away from the fitting.
- 4) To remove tubing press the olive against the fitting, and pull tube out.

### **COMMISSIONING.**

- 1) Once all the above conditions have been carried out and the wiring checked, apply power to the LPN-DP (Rev 1) loop and allow five minutes for it to stabilise.
- 2) Take a low and high reading of the variable being measured by the transducer supplying the signal to the LPN-DP (Rev 1), and ensure that this agrees with the level being indicated by the PLC or Indicator, etc, that the LPN-DP (Rev 1) is connected into.

### **MAINTENANCE.**

- 1) Repeat (2) of Commissioning.
- 2) Do it regularly - at least once every 12 months.