

JUMO AQUIS 500 Ci

Transmitter/Controller for Inductive Conductivity,
Concentration and Temperature
Type 202566



B 202566.0
Operating Instructions



**WARNING:**

A sudden malfunction of the device, or one of the sensors connected to it, could potentially result in dangerous, imprecise dosing! Suitable preventive measures must be in place to prevent this from happening.



**Note:**

Please read these Operating Instructions before placing the device in operation. Keep the manual in a place which is accessible to all users at all times.

**Resetting the brightness of the LC display:**

If the brightness/contrast setting has been adjusted so that the display text is no longer legible, the basic setting can be restored as follows:

Switch off the supply voltage.

Switch on the supply voltage and immediately press and hold the  and  keys simultaneously.

Reset the language to "English":

If the language has been adjusted so that the display text is no longer comprehensible, use the Administrator password, 7485, to reset the language to "English":

Press the  key for longer than 3 seconds.

Press the  key once.

Briefly press the  key.

Enter 7485.

Briefly press the  key.

The required language can then be set in

ADMINISTR. LEVEL / PASSWORD / PARAMETER LEVEL / DISPLAY / LANGUAGE.

Contents

1	Typographical conventions	5
1.1	Warning symbols	5
1.2	Reference symbols	5
2	Description	6
3	Identifying the device version	9
3.1	Nameplate	9
3.2	Order details	9
3.3	Accessories (optional)	10
4	Mounting	11
4.1	General	11
4.2	Surface mounting the transmitter	11
4.3	Pipe installation set / weather protection roof	12
4.4	DIN rail installation set	12
4.5	Mounting in a panel	13
4.6	Fitting the conductivity sensor	15
5	Electrical connection	16
5.1	Installation notes	16
5.2	Electrical isolation	17
5.3	Opening and closing the device	18
5.4	Connecting the cables	19
5.5	Terminal assignment	20
5.6	Pin assignment	21
6	Operation	23
6.1	Controls	23
6.2	Display	24
6.3	Principle of operation	25
6.4	Parameter overview	26
6.5	Measuring mode	28
6.6	Input/output information	28
6.7	MANUAL mode / simulation mode	30
6.8	HOLD mode	34
6.9	Operator level	35
6.10	Administrator level	35
6.11	Device info	40
6.12	Controller functions	41

Contents

7	Startup	42
7.1	Getting started	42
7.2	Setting example	43
8	Calibrating inductive conductivity cells	48
8.1	Notes	48
8.2	General	48
8.3	Calibrating the relative cell constant	49
8.4	Calibrating the temperature coefficient of the measurement solution	51
8.5	Calibration logbook	57
9	Setup program	58
9.1	Function	58
10	Eliminating errors and faults	59
11	Technical data	61
11.1	Main input conductivity	61
11.2	Secondary input temperature	61
11.3	Temperature compensation	62
11.4	Measuring circuit monitoring	62
11.5	Cell constant	62
11.6	Binary input	62
11.7	Controller	63
11.8	Switching outputs (max. two (SPDT) changeovers)	63
11.9	Setup interface	63
11.10	Electrical data	63
11.11	Display	63
11.12	Housing	63
11.13	Analog outputs (max. 2)	64
11.14	Approvals/marks of conformity	64
12	Appendix	65
12.1	Operator level parameters	65
12.2	Glossary	76
12.3	Template for panel cutout	82
13	Index	83

1 Typographical conventions

1.1 Warning symbols



Danger

This symbol is used when there may be **danger to personnel** if the instructions are ignored or not followed correctly!



Caution

This symbol is used when there may be **damage to equipment or data** if the instructions are ignored or not followed correctly!

1.2 Reference symbols



Note

This symbol is used to draw your **special attention** to a remark.

abc¹

Footnote

Footnotes are remarks that **refer to specific points** in the text. Footnotes consist of two parts:

A marker in the text and the footnote text.

The markers in the text are arranged as consecutive superscript numbers.

*

Instruction

This symbol indicates that an **action to be performed** is described.

The individual steps are marked by this asterisk.

Example:

* Loosen Phillips-head screws.

2 Description

General information

The JUMO AQUIS 500 CI is used for the inductive measurement / control of electrolytic conductivity or of the concentration of liquids. With this device, it is also possible to display the measured conductivity in accordance with a specifically customized table.

Inductive JUMO measuring cells can be connected to the device.

Temperature measurement is performed with a Pt100/1000, as a second input variable. Specific, automatic temperature compensation is possible here, depending on the measurement variable.

The device is operated by keys, and has a large, easily legible graphic display. Parameters are displayed in plain text, making configuration easier for the user and helping with the proper programming of the device.

Input signals can be shown as numbers or as a bar graph on the graphic display. Parameters are displayed in plain text for easily comprehensible and secure operation.

With two optional relay switching contacts, it is possible to implement both simple switching or alarm functions and demanding control tasks with P, PI, PD and PID action. If required, the device can also be provided with two freely configurable and scalable analog outputs (0 - 10 V or 0(4) - 20 mA).

Advantages

With the inductive measurement method, acquisition of the specific conductivity is largely maintenance-free, even in difficult medium conditions. Unlike the conductive measurement method, problems such as electrode breakdown and polarization simply do not occur.

Because temperature measurement is integrated, temperature compensation takes place quickly and precisely, which is particularly important when measuring conductivity.

Typical areas of application

Particularly recommended is use in media in which heavy deposits from contaminants, oil and grease, or gypsum and lime precipitation are to be expected.

According to which sensor is connected, the device can be used in

- fresh water and waste water
- air conditioning systems and cooling tower monitoring
- swill tanks (e.g. electroplating plant monitoring)
- feed and final control in in-house wastewater treatment plants
- concentration monitoring
- vehicle washers
- CIP cleaning (**C**lean **I**n **P**lace / **P**rocess)
- concentration monitoring and chemicals dosing
- food, drinks and pharmaceutical industries (monitoring phase separation)

2 Description

Measuring circuit arrangement

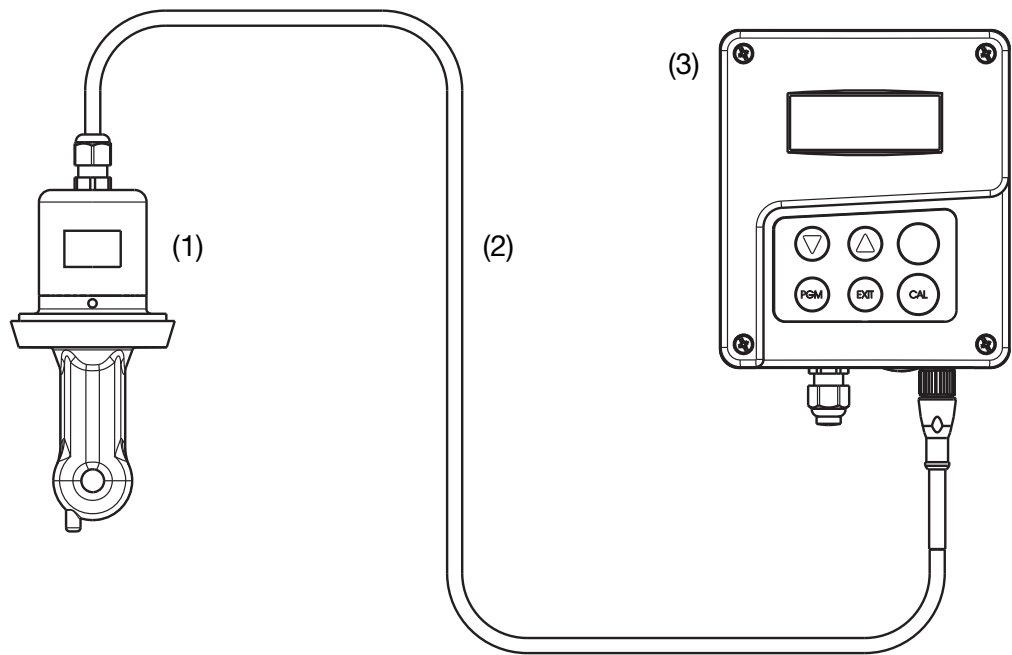

- (1) JUMO tecLine Ci, inductive conductivity and temperature sensor
- (2) Cable (JUMO tecLine Ci component)
- (3) JUMO AQUIS 500 Ci, transmitter/controller for conductivity, concentration and temperature

Key features

- Display: mS/cm, μ S/cm, g/l, etc. Special visualizations can also be configured with the setup program.
- Large, backlit LC graphic display.
- A choice of display visualizations: large numbers, bar graph or trend display.
- Integrated calibration routines.
- Calibration logbook.
- IP67 enclosure protection for surface mounting
IP65 enclosure protection for switch cabinet mounting
- Selectable languages: German, English, French; additional languages can be loaded later through the setup program.
- Through the setup program: user-friendly programming, system documentation, subsequent loading of additional languages.

2 Description

Block diagram

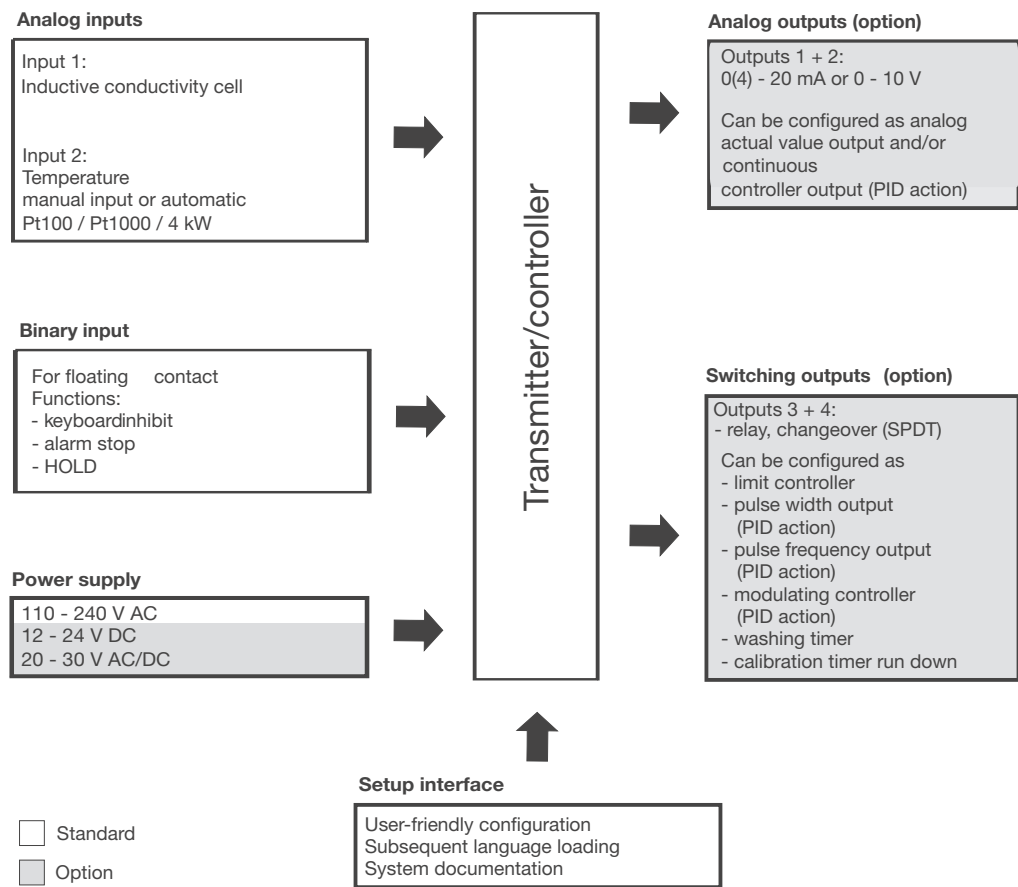

3 Identifying the device version

3.1 Nameplate

on the transmitter

JUMO AQUIS 500 Ci TN: 00491200

Typ: 202566/10-888-000-000-000-23/000

F-Nr.: 0168122901016010001

~ AC 110..240V -15/+10% 48..63Hz ≤ 14VA



The date of manufacture is encoded in "F No." (serial number):

1601 means manufactured in 2016, week 01.

3.2 Order details

- (1) Basic type**
202566 JUMO AQUIS 500 CI
transmitter/controller for conductivity, concentration and temperature
- (2) Basic type extension**
 - 10 for panel mounting
 - 20 in surface-mounted housing
- (3) Output 1 (for main value or continuous controller)**
 - 000 no output
 - 888 analog output 0(4) - 20 mA and 0 - 10 V
- (4) Output 2 (for temperature or continuous controller)**
 - 000 no output
 - 888 analog output 0(4) - 20 mA and 0 - 10 V
- (5) Output 3**
 - 000 no output
 - 310 relay with changeover contact
- (6) Output 4**
 - 000 no output
 - 310 relay with changeover contact
- (7) Power supply**
 - 23 110 - 240 V AC, +10% / -15%, 48 - 63 Hz
 - 25 20 - 30 V AC/DC, 48 - 63 Hz
 - 30 12 - 24 V DC, ± 15%¹
- (8) Extra codes**
 - 000 none

Order code (1) / (2) - (3) - (4) - (5) - (6) - (7) / (8) , ...¹
Order example 202566 / 20 - 888 - 888 - 310 - 310 - 23 / 000

3 Identifying the device version

3.3 Accessories (optional)

Type	Part no.
Protective roof for JUMO AQUIS 500	00398161
Pipe installation set for JUMO AQUIS 500 ¹	00483664
DIN rail installation set for JUMO AQUIS 500 ²	00477842
Support pillar with base clamp, arm and chain	00398163
Holder for suspension fitting	00453191
Back panel set 202560/65	00506351
PC setup software	00483602
PC interface cable including USB/TTL converter and two adapters (USB connecting cable)	00456352
Calibration adapter for inductive conductivity measurement, type 202711/21	00544942

¹ With the pipe installation set, the JUMO AQUIS 500 can be attached to a pipe (e. g. a support pillar or a railing).

² With the DIN rail installation set, the JUMO AQUIS 500 can be attached to a 35 mm x 7.5 mm DIN rail as per EN 60715 A.1.



The following are required for the initial commissioning of the sensor and transmitter/controller or when replacing components:

- the JUMO AQUIS 500 Ci transmitter/controller, data sheet 20.2566
- an inductive conductivity and temperature sensor JUMO tecLine Ci

a calibration adapter for inductive conductivity measurement, type 202711/21, data sheet 20.2711

4.1 General

Mounting location

Find a location that ensures easy accessibility for the later calibration.

The fastening must be secure and must ensure low vibration for the device.
Avoid direct sunlight!

Permissible ambient temperature at the installation location: -10 to 55°C with max. 95% rel. humidity, no condensation.

Installation position

The device can be mounted in any position.

Insertion and removal of separate screw-in sensor



The cable between the transmitter and the conductivity sensor must not be damaged (twisted, shortened, etc.).

Avoid pulling on the cable, especially jerkily.

4.2 Surface mounting the transmitter



Befestigungslaschen (1) sind im Lieferumfang enthalten.

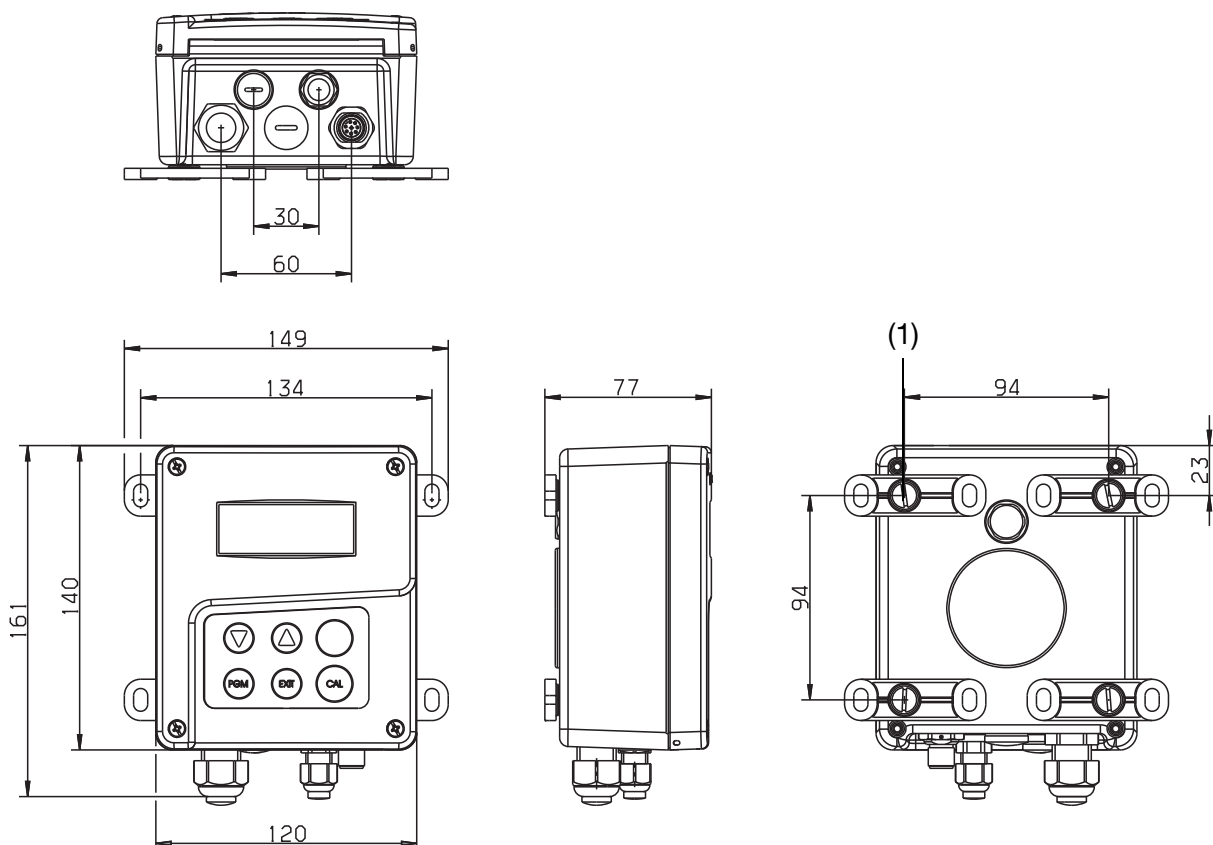

4 Mounting

Attachment

- * Screw four fixing brackets (1) onto the enclosure.
The fixing brackets can be turned in increments of 90°.
- * Attach the housing to a surface by the fixing brackets (with screws, dowels, etc.).

4.3 Pipe installation set / weather protection roof

The pipe installation set for JUMO AQUIS 500 (part no.: 00483664) can be used to fasten the device (and optionally the protective roof for JUMO AQUIS 500, part no.: 00398161) onto pipes or railings with a diameter from 30 to 50 mm.

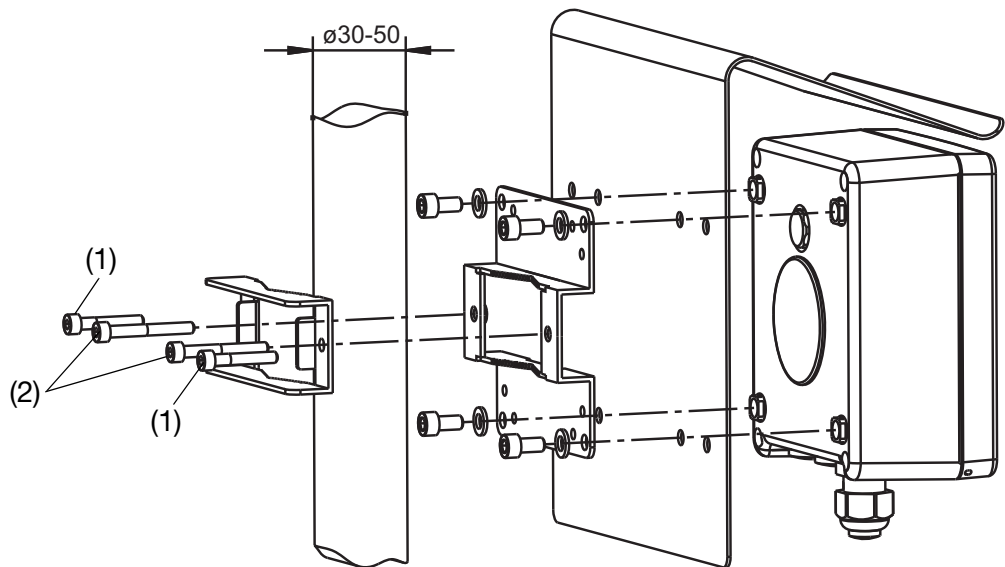

Screws (1) M5 x 30 for pipe diameters from 30 to 40 mm.

Screws (2) M5 x 40 for pipe diameters from 40 to 50 mm.

The pipe installation set is also suitable for horizontal pipes.

4.4 DIN rail installation set

The DIN rail installation set for JUMO AQUIS 500 (part no.: 00477842) can be used to attach the device to a 35 mm x 7.5 mm DIN rail, as per EN 60715 A.1.

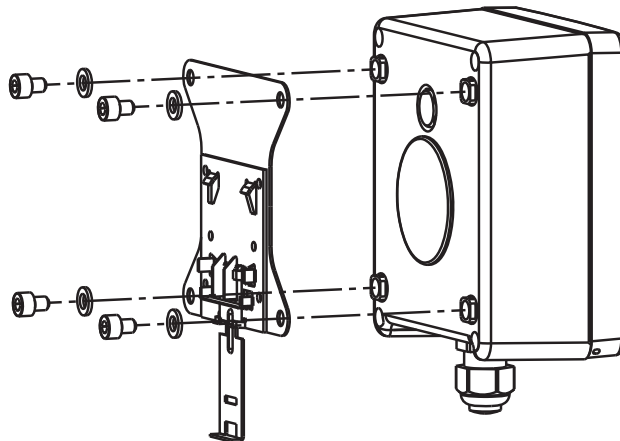

4.5 Mounting in a panel

Panel cut-out



Drilling template See section 12.3 "Template for panel cutout", page 82.

The panel must be sufficiently thick to achieve the specified IP65 enclosure protection!

Installation

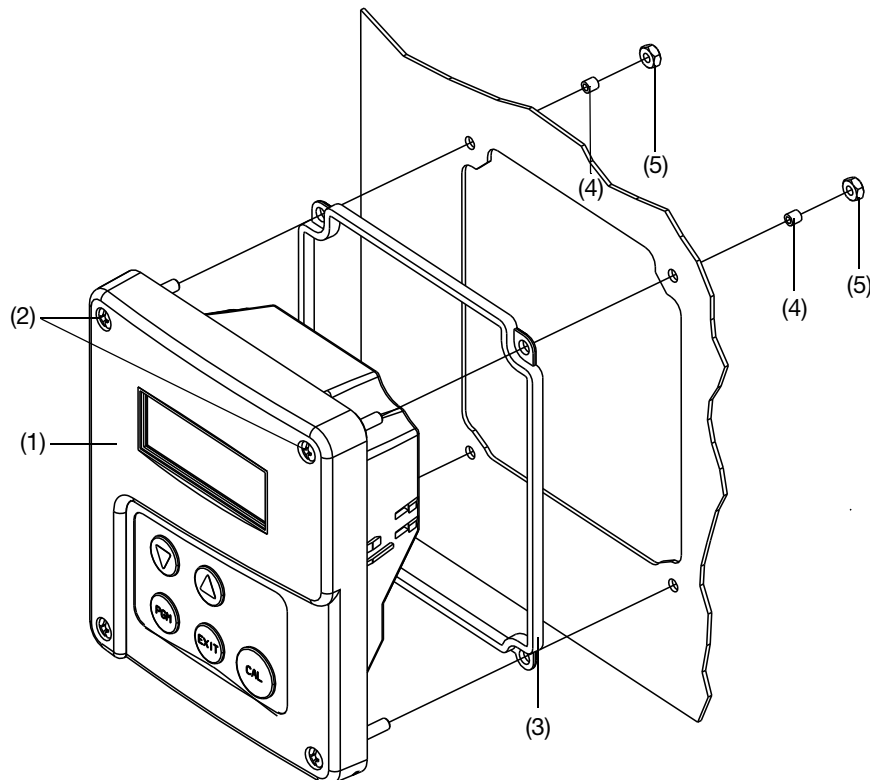

- * Prepare the panel cut-out and holes based on the drill template.
- * Place the control panel (1) with gasket (3) in the panel cut-out and fasten it with the two upper screws (2) spacing rollers (3) and nuts (4).

To ensure electrical safety, the cable cover must be mounted, see next page!



4 Mounting

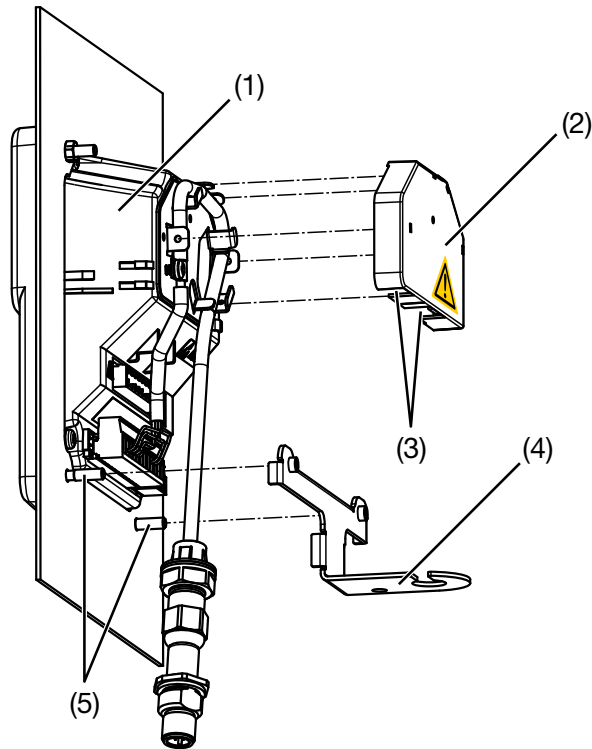

- * Fit the bracket (4) for strain relief with the two lower screws (5).
- * Make the electrical connection, See section 5 "Electrical connection", page 16.
- * Break off the required flap(s) (3) from the cable cover (2) so that the cable can be laid in the cable path.
- * Attach the cable cover (2) onto the control panel (1).

Depth behind panel

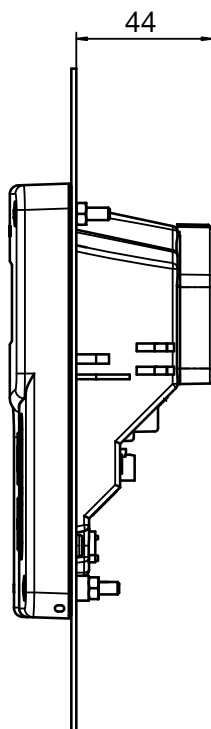

Attaching the M12 round plug

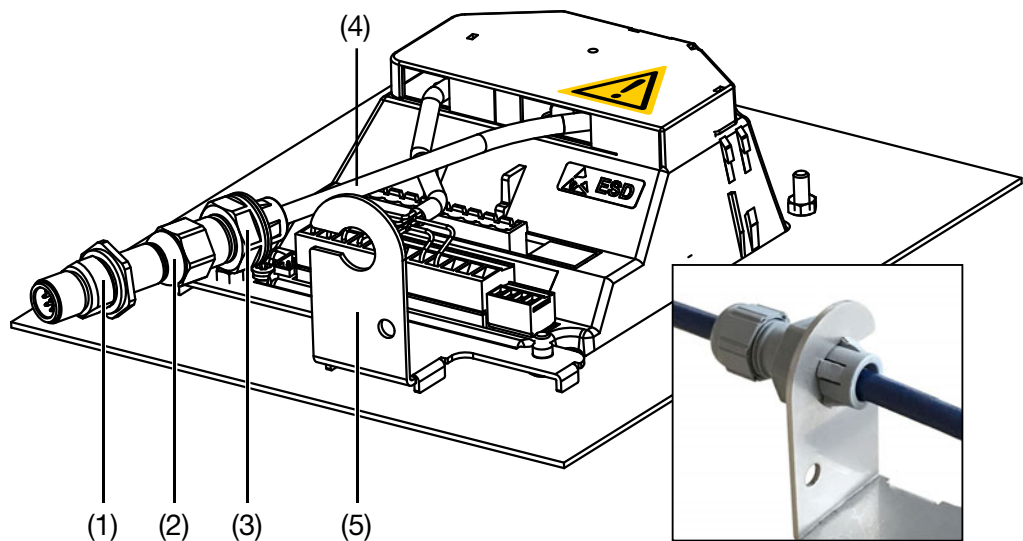

- * Insert the connecting cable (4) into the recess of the bracket (5) for strain relief.
- * "Click" the gland from below into the recess of the bracket (5), like shown in the photo right above.
- * Tighten the pressure nut (3) (left-hand thread).
- * Tighten the acorn nut (2), to incorporate strain relief to the circular plug M12 (1) and the connecting cable (4).

4.6 Fitting the conductivity sensor



Only inductive conductivity sensors of the JUMO tecLINE Ci type, see data sheet 202941, can be connected to the JUMO AQUIS 500 Ci.

The installation of these conductivity cells is described in operating instructions B 202941.4.

5 Electrical connection

5.1 Installation notes



The electrical connection must only be performed by qualified personnel!

The choice of cable, the installation and the electrical connection must conform to the requirements of VDE 0100 "Regulations on the Installation of Power Circuits with Nominal Voltages below 1000 V" or the appropriate local regulations. **Only flexible cables and wires shall be used!**

If contact with live parts is possible while working on the device, it must be completely disconnected from the electrical supply.

Load circuits must be fused for the maximum relay current in each case, in order to prevent welding of the relay contacts in the event of a short circuit.

The electromagnetic compatibility conforms to EN 61326.

Run input, output and supply cables separately and not parallel to one another.

Use shielded sensor cables with twisted conductors. Do not run these cables close to current-carrying components or cables. Ground shielding at one end.

Sensor leads should be implemented as uninterrupted cables (not routed via terminal blocks etc.).

Do not connect any additional loads to the supply terminals of the device.

The device is not suitable for use in areas with an explosion hazard (Ex areas).

Apart from faulty installation, incorrect settings on the device may also affect the proper functioning of the subsequent process or lead to damage. Safety devices independent of the device should therefore always be provided and should only be capable of adjustment by specialist personnel.

Conductor cross-sections and ferrules

Mounting information

	Minimum cross-section	Maximum cross-section	Minimum ferrule length
Without ferrule	0.34mm ²	2.5mm ²	10mm (stripped)
Ferrule without collar	0.25mm ²	2.5mm ²	10mm
Ferrule with collar, up to 1.5mm ²	0.25mm ²	1.5mm ²	10mm
Ferrule with collar, from 1.5mm ²	1.5mm ²	2.5mm ²	12mm
Twin ferrule with collar	0.25mm ²	1.5mm ²	12mm



The enclosure protection specified for the device (IP67) is only achievable if not more than one cable runs into the device through each cable gland.

5.2 Electrical isolation

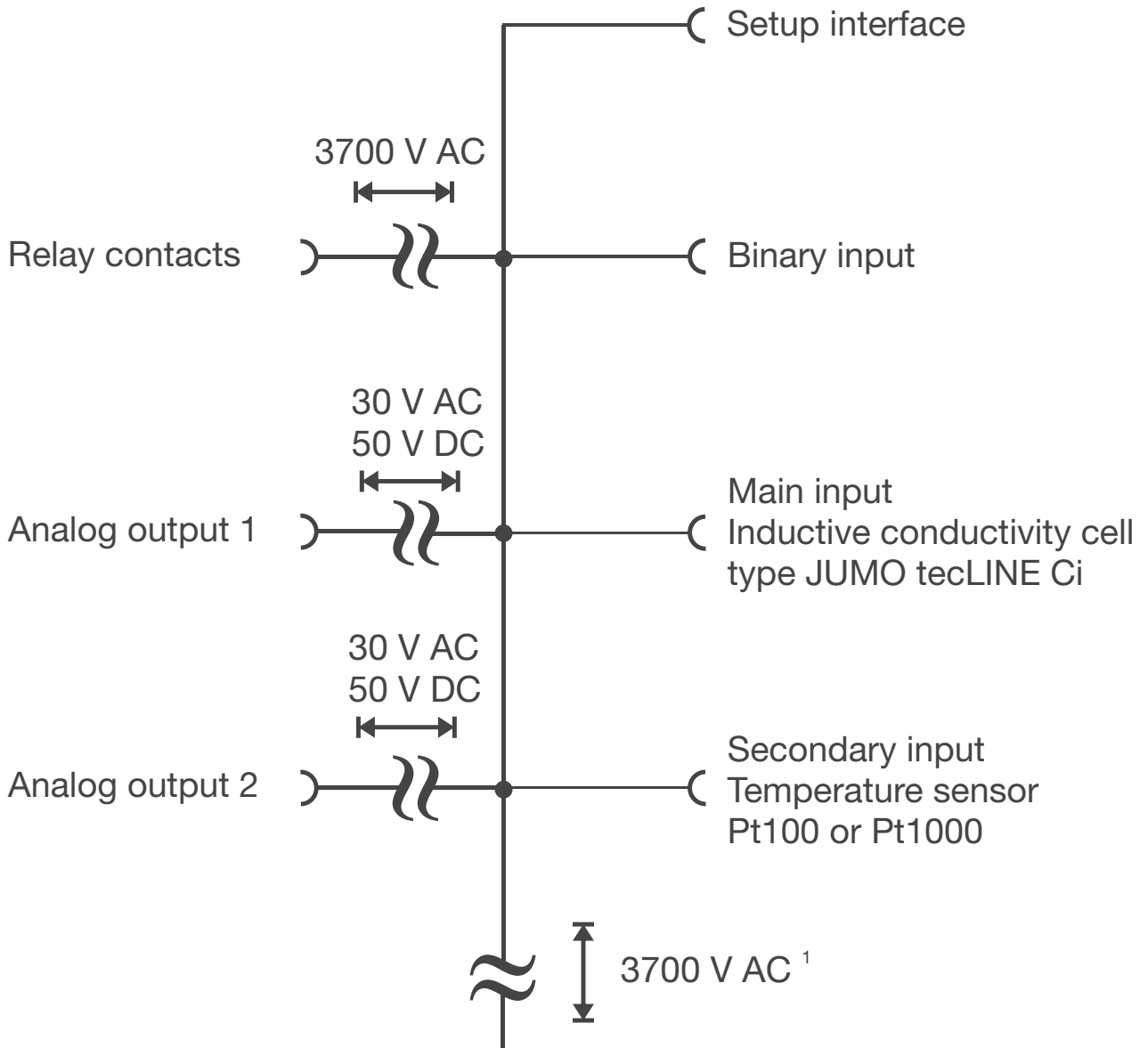

¹ Not for SELV/PELV of 30 (12 - 24 V DC) supply voltage !

5 Electrical connection

5.3 Opening and closing the device



Opening the device

- * Prior to opening, loosen all cable fittings (2) so that the cables are moveable.
- * Push connection cable a little into the case so that enough cable reserve is available for opening.
- * Loosen the 4 front-panel screws (1) of the case lid and pull them out as much as possible.
- * Pull the lid to the front and then fold to the front. The user needs to be able to easily open the lid. Do not use force while opening!

Closing the device

- * When closing the device, pull the connecting cables to the outside while the cable fittings are in a released state and make sure that the lines in the inside of the device run properly. Pay attention to the corresponding sheathing measurement to ensure strain relief and protection type (IP67) of the cable fitting.
- * The user must be able to close the lid with the 4 screws without a high degree of pressure.
- * Tighten cable fittings.

5.4 Connecting the cables

The electrical connection for the surface-mountable housing is easily accessible when the device is folded out.

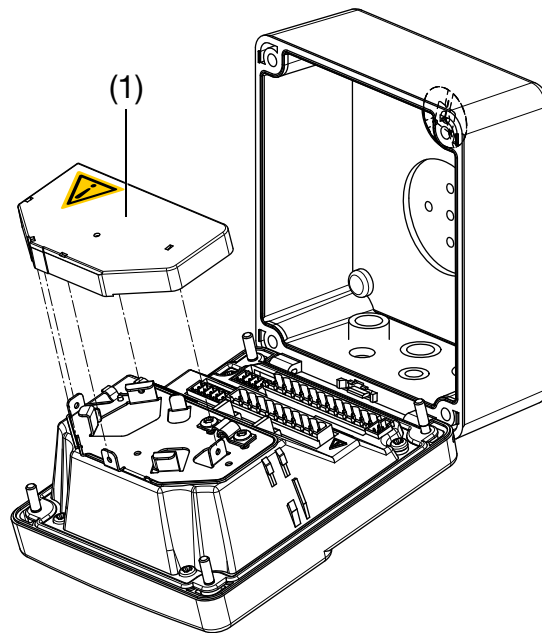

The device contains a guide plate that ensures an optimum cable path. **After laying the cables, the cable cover (1) must be attached until it clicks, like shown above. This is important to ensure the electrical safety!**

To connect the individual core wires, remove pluggable screw terminals from the control panel.

Run the connecting cables through the cable glands.



The clip (3) (see next page) must **only** be attached by a 3.5 x 6.5 pan head screw! If the screw is any longer, dangerous voltage could be directed to the cable shielding!

5 Electrical connection

Interior view

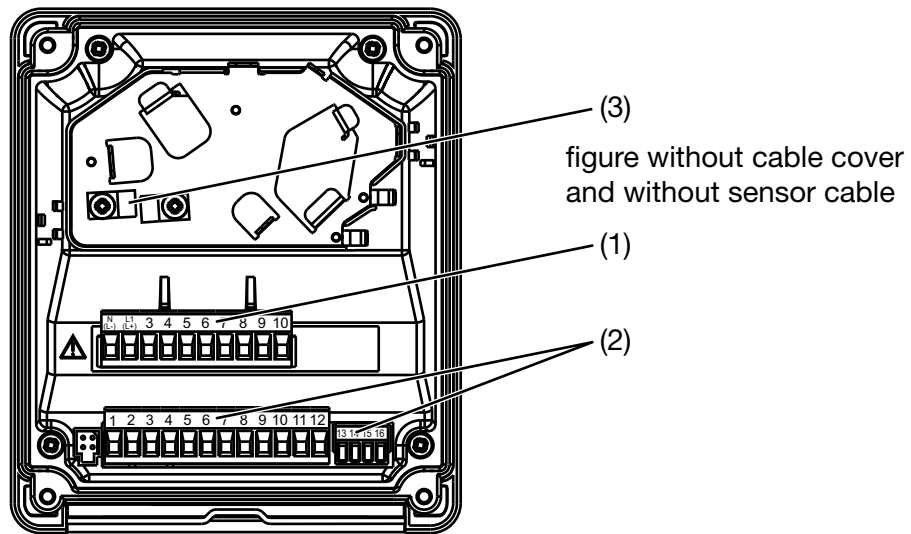

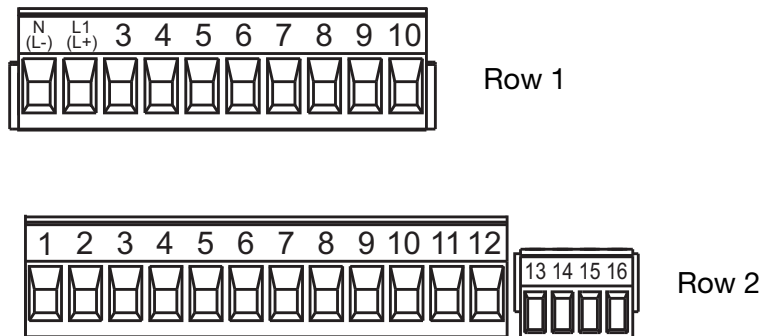

- * Lead the connecting cables in through the cable fittings.
- * In case of rerouting the sensor cable: use the cable clip (3) to clamp the signal cable to the shielding.
- * Break off the required flap(s) from the cable cover so that the cable can be laid in the cable path. Attach the cable cover.
- * Connect the cores as assigned below, and see section 5.6 "Pin assignment", page 21.
- * Push the plug-in terminals for row 1 (1) and row 2 (2) into the sockets in the device.

5.5 Terminal assignment

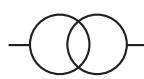
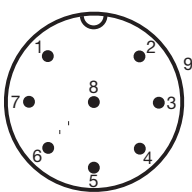
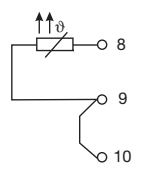
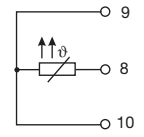
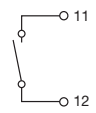

5 Electrical connection

5.6 Pin assignment

Connection		Terminal	Row
Inputs			
Power supply (23): 110 - 240 V AC, + 10% / -15%, 48 - 63 Hz Power supply (25): 20 - 30 V AC/DC, 48 - 63 Hz Power supply (30): 12 - 24 V DC, ± 15%		1 N (L-) 2 L1 (L+)	1
NC		3	
Only JUMO tecLINE Lf Ci inductive conductivity cells can be operated at the M12 connector, see data sheet 20.2941.		1 2 3 4 5 6 7 8 9	
Resistance thermometer in 2-wire circuit		8 9 10	2
Resistance thermometer in 3-wire circuit		8 9 10	
Binary input		11 12	
Outputs			
Analog output 1 0 - 20 mA and 20 - 0 mA or 4 - 20 mA and 20 - 4 mA or 0 - 10 V and 10 - 0 V (electrically isolated)		+ 13 - 14	2
Analog output 2 0 - 20 mA and 20 - 0 mA or 4 - 20 mA and 20 - 4 mA or 0 - 10 V and 10 - 0 V (electrically isolated)		+ 15 - 16	

 means: Do **not** modify the factory wiring!

5 Electrical connection

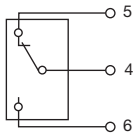
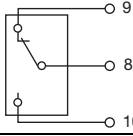
Connection		Terminal	Row
Switching output K1 (floating)		4 pole 5 NC 6 NO	1
NC		7	
Switching output K2 (floating)		8 pole 9 NC 10 NO	





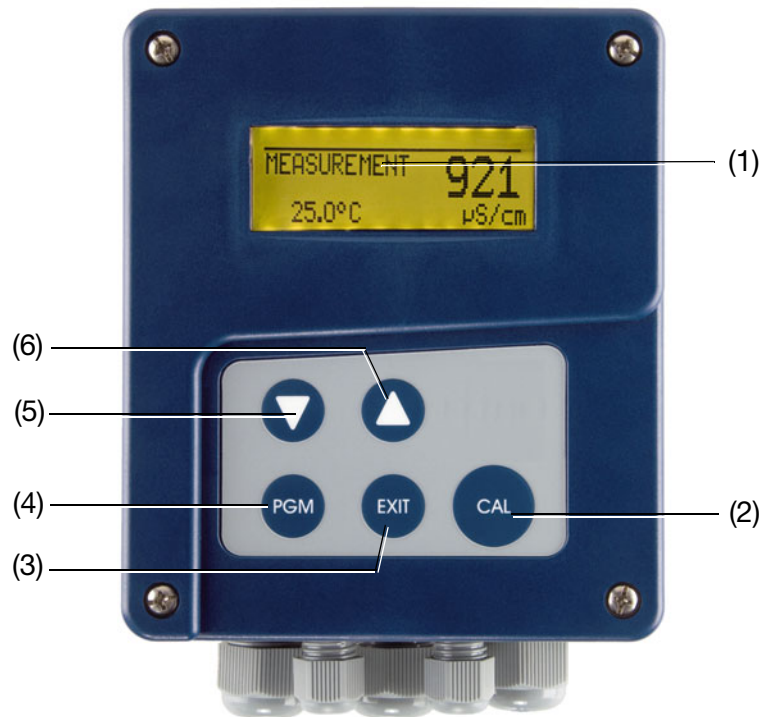

device operation via the optional set-up program, See section 9 "Setup program", page 58.

Operation via the device keypad is described below.

6.1 Controls



- | | | |
|-----|---|--|
| (1) | Display | backlit (during operation) |
| (2) |  key | Start calibration |
| (3) |  key | Cancel entry / Exit level |
| (4) |  key | Change level
Forward selection
Confirm selection |
| (5) |  key | Reduce numerical value
Forward selection |
| (6) |  key | Increase numerical value
Forward selection |

6 Operation

6.2 Display

6.2.1 Measuring mode (normal display)

Example

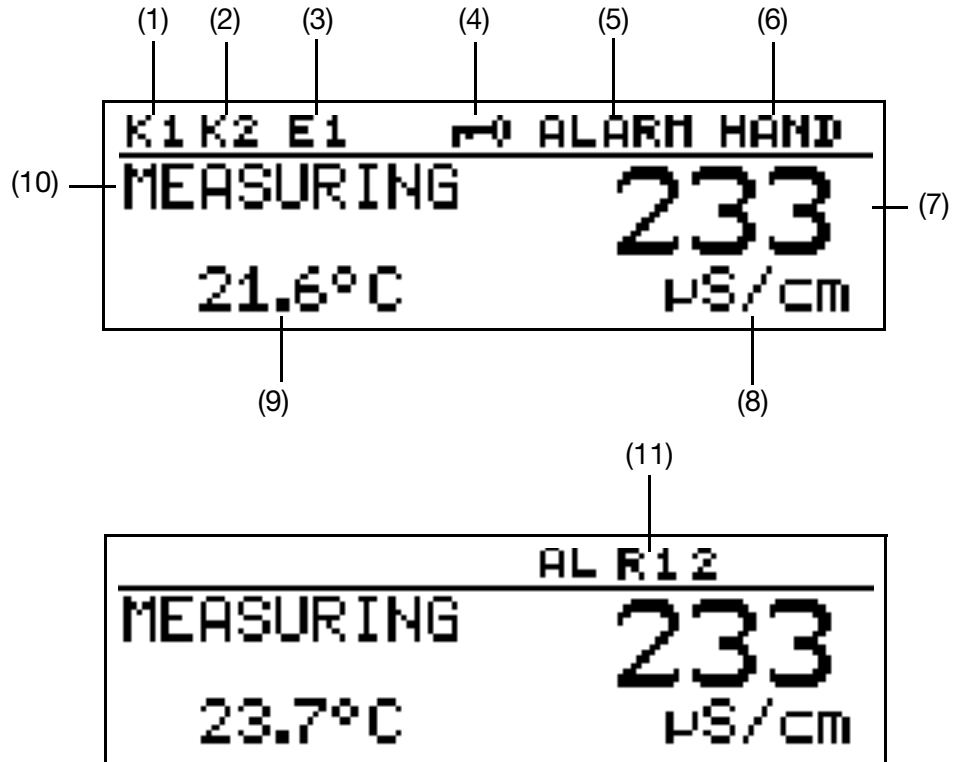

- | | |
|---|--|
| (1) Relay K1 is active | (7) Measurement value |
| (2) Relay K2 is active | (8) Measurement unit |
| (3) Binary input 1 is triggered | (9) Temperature of medium |
| (4) Keypad is locked | (10) device status e.g.
- Measuring (normal)
- Calibration status |
| (5) device status (notes)
- Alarm (e.g. overrange)
- Calib flashes (calibration timer expired)
- Calib (customer calibration active) | (11) AL R1 = Alarm, controller 1
AL R2 = Alarm, controller 2
AL R12 = Alarm, controllers 1 and 2 |
| (6) Output mode
- Man (manual mode)
- Hold (hold mode) | |



To return to measuring mode (MEASURING):
press the  key or wait for a "timeout".

6.3 Principle of operation

6.3.1 Operation in levels

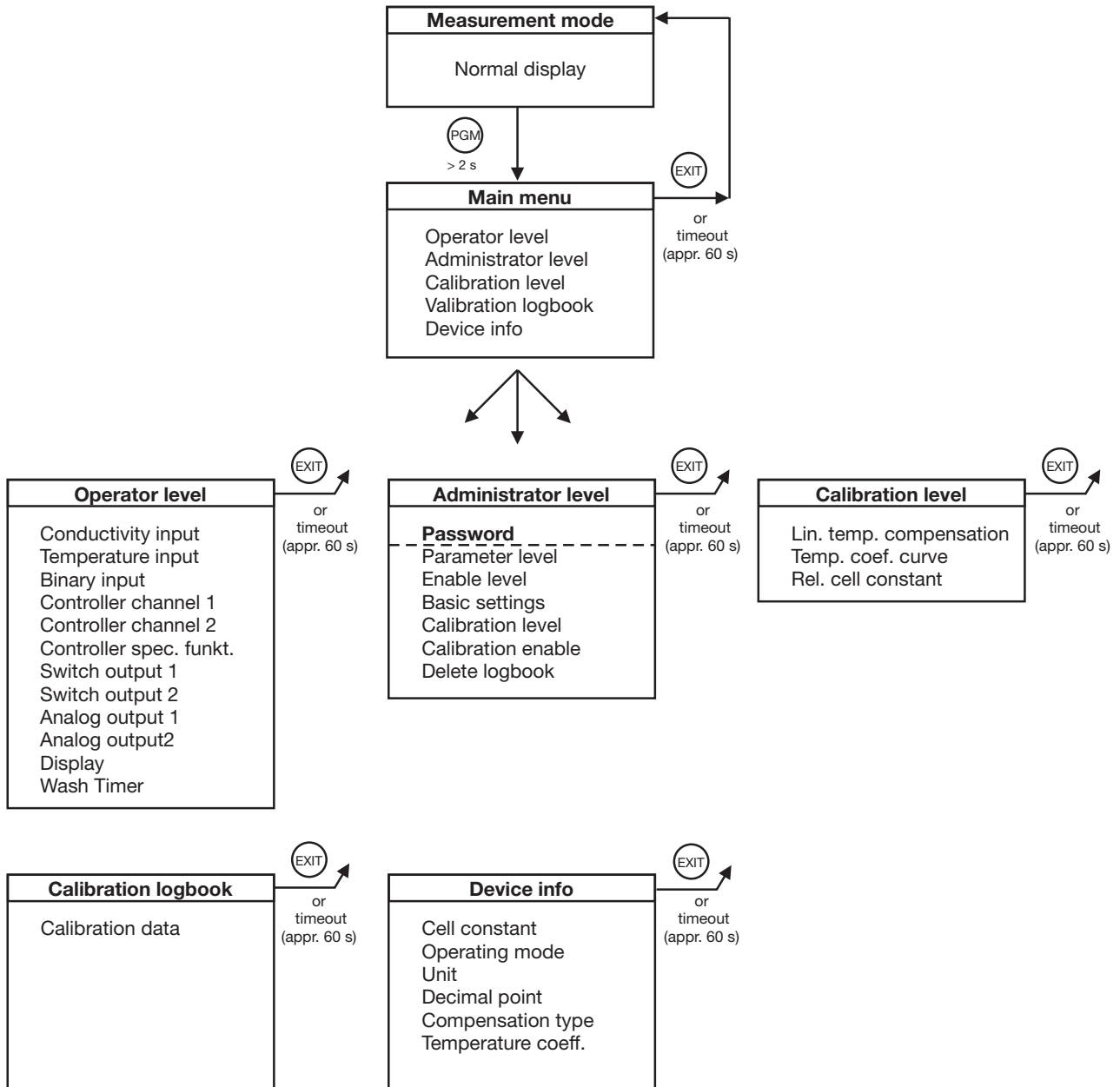

6 Operation

6.4 Parameter overview

Measuring mode (normal display); See section 6.5 "Measuring mode", page 28

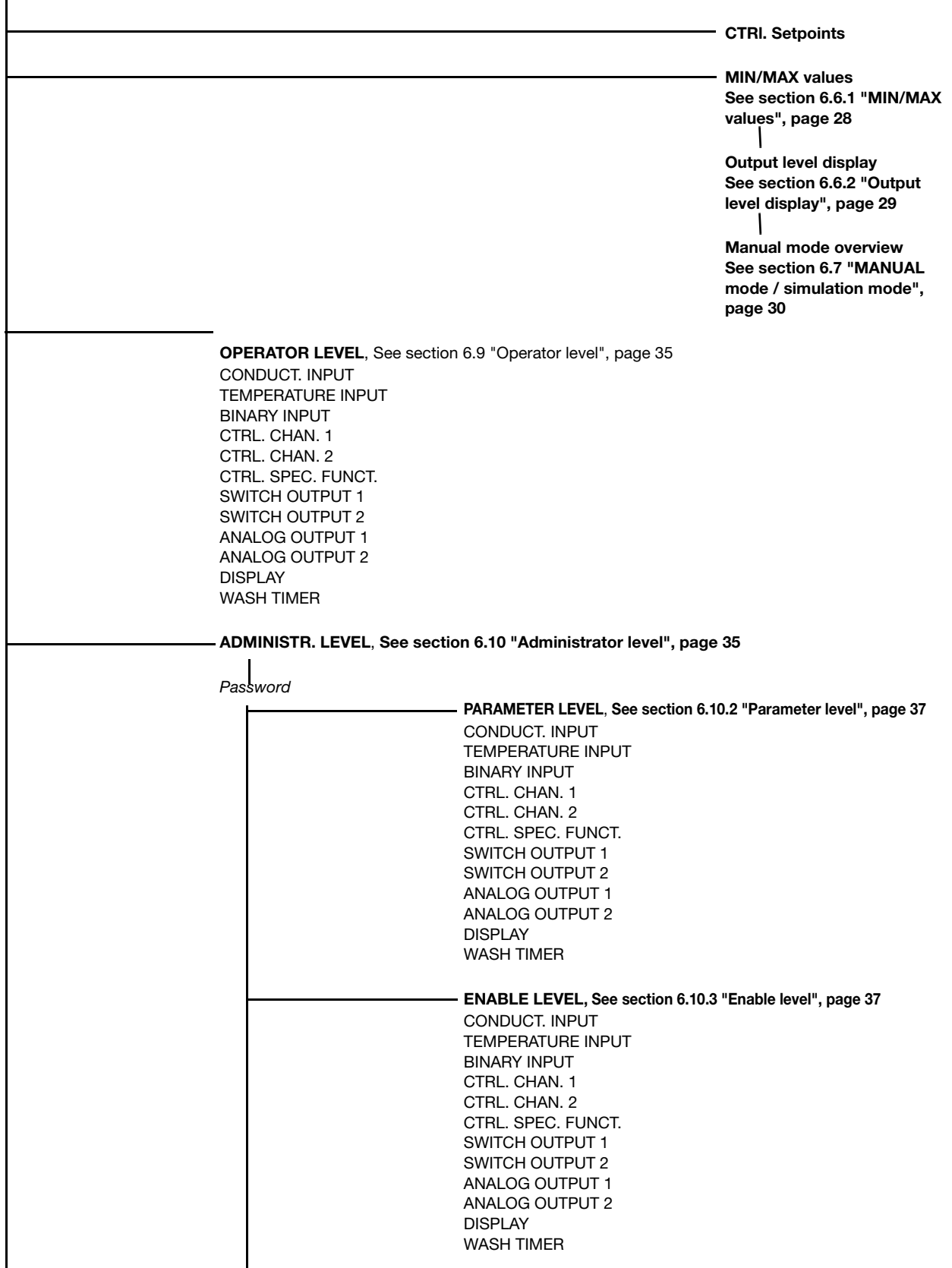

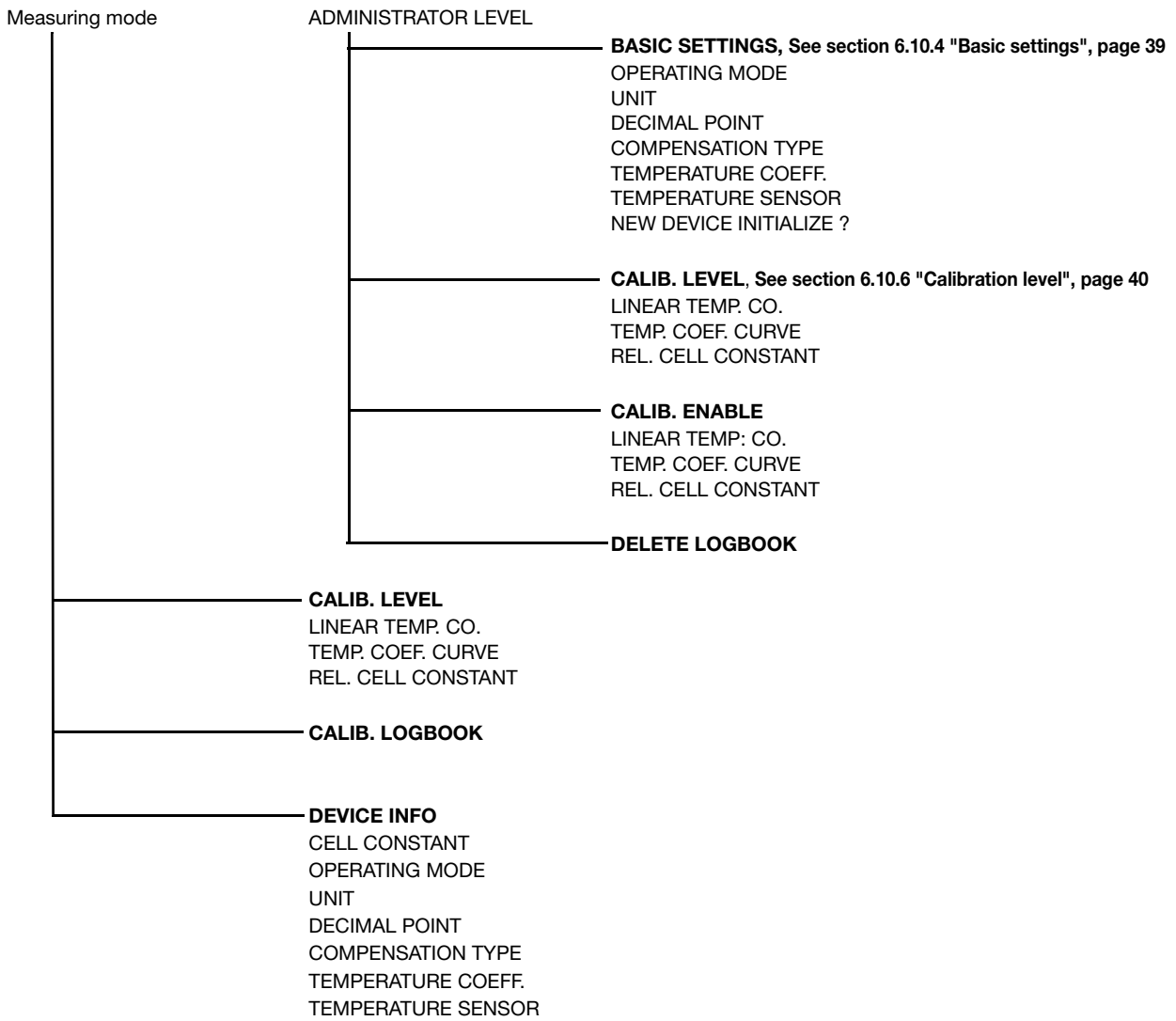

6 Operation

6.5 Measuring mode

6.5.1 Normal display

- Visualization** The following are displayed in measuring mode:
- the analog input signal
 - the unit: (configurable as pH, mS/cm, $\mu\text{S}/\text{cm}$, ppm, %, mV, etc.)
 - the temperature of the medium

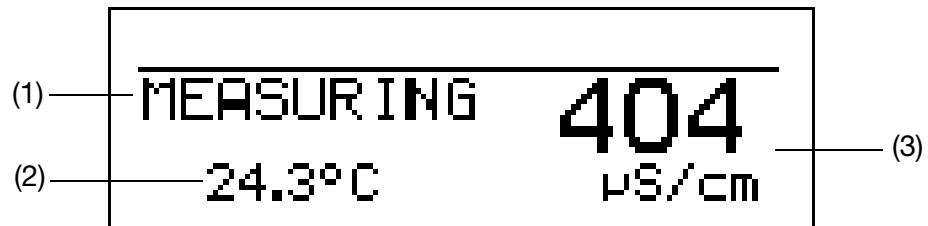

- (1) MEASURING -> measuring mode
- (2) 24.3 -> the temperature of the medium
- (3) 404 $\mu\text{S}/\text{cm}$ -> the measurement value calculated from the standard signal at the input



The "trend display" or "bar graph" display types can also be selected in measuring mode, See "MEAS. DISPLAY TYPE" page 73.

6.6 Input/output information

6.6.1 MIN/MAX values

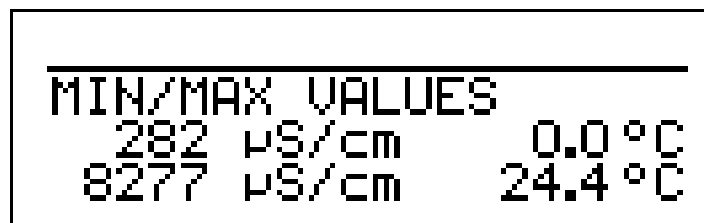

Activating the display of min/max values

- The device is in measuring mode (normal display)
- * Press the  key for less than 2 seconds.
The minimum and maximum values of the main variable (conductivity, concentration, etc.), and the temperature are displayed.

The extreme values of the main measurement variable and the temperature are **not** mutually assigned (e. g. not 282 $\mu\text{S}/\text{cm}$ at 0.0°C).



To return to measuring mode: press the **EXIT** key or wait for a "timeout".

Measurements with "out of range" are ignored.

Press the **PGM** key again briefly to go to "Output level display" mode.

The min./max. value memory can be reset:

Operator level / Display / Min./max. reset.

If the basic setting is changed or there is a loss of power, the min and max values are deleted.

6.6.2 Output level display

```
OUTPUT LEVEL
CONTROLLER 1    0%
CONTROLLER 2    0%
```

The device is in measuring mode (normal display)

* Press the **PGM** key twice for less than 2 seconds.

The output level of both controller contacts will be displayed (if available).



The output level of an output can only be displayed if the output concerned has been configured:

e.g. Administrator level / Parameter level / Controller channel 1 or 2.

To return to the normal display:

Press the **EXIT** key or wait for a "timeout".

Press the **PGM** key again to go to "Manual mode overview" mode.

6 Operation

6.7 MANUAL mode / simulation mode

These functions can be used to manually set the switching outputs and analog outputs of the device to a defined state. This facilitates dry startup, troubleshooting and customer service, for example.

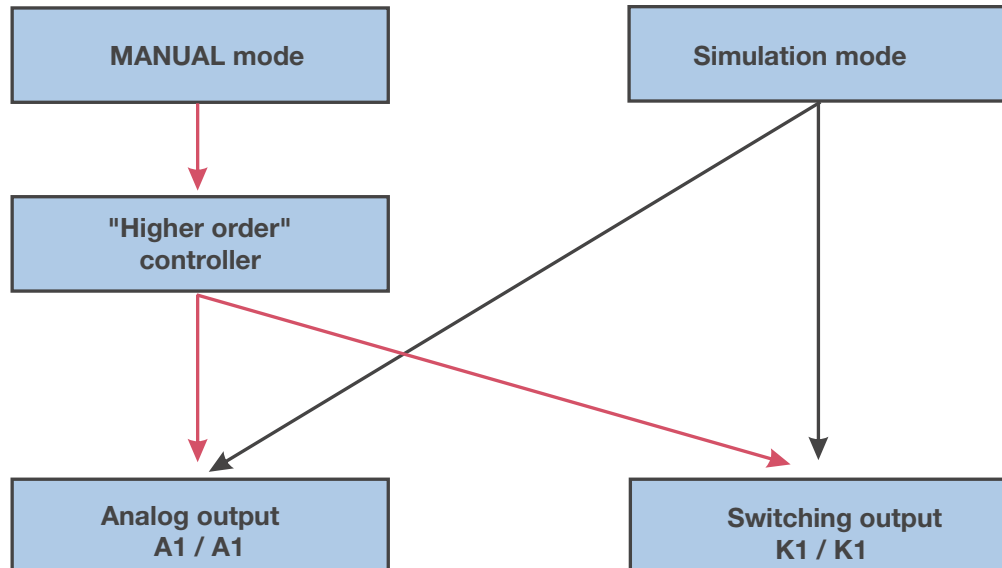

Simulation mode **directly** accesses switching outputs K1/2 or analog outputs 1/2. When simulation mode has been selected, MANUAL mode is **not** possible!

In MANUAL mode the settings for "higher order controllers" are taken into consideration.

6.7.1 MANUAL mode via "higher order control functions"

Higher order switching functions

The JUMO AQUIS 500 is configured for **higher order control functions** when the following setting is made:

User level / controller channel 1 or 2 / control type **Limit value or pulse width or pulse frequency or modulating or continuous controller**.

When the configuration is set to continuous controller, analog outputs 1 and/or 2 are activated in manual mode. In other configurations switching outputs K1 or K2 are switched.

Selecting manual mode



In the factory setting of the device the MANUAL mode parameter is locked and can **only be activated by the Administrator!**

This parameter must first be enabled for other users, **See section 6.10.3 "Enable level", page 37.**

* Set Administrator level / Password / Parameter level / Special controller functions / Manual mode locked, **Pulsed** or **Switched**.



Locked = No manual mode, control via JUMO AQUIS 500.

Pulsed = the outputs are active as long as the ▼ or ▲ key is pressed.



Switched = the outputs are active if the ▼ or ▲ key is pressed. If the corresponding key is pressed again, the output becomes inactive again.

Activating manual mode

The device is in display mode

- * Press the  and  keys for less than 2 seconds.
The word MANUAL appears in the status line of the display.



If the  and  keys are pressed for longer than 3 seconds, the device goes into HOLD mode.

Then the outputs of the device respond according to the default settings.

To exit HOLD mode, press the  and  keys for longer than 3 seconds.

Control is no longer through the JUMO AQUIS 500. The output level of the controller channels is 0%.

Controller channel 1 is activated by the  key. In this case the output level of controller channel 1 is 100%.

Controller channel 2 is activated by the  key. In this case the output level of controller channel 2 is 100%.

Deactivation

- * Press the  key.

Control is once again through the outputs of the device.

The word MANUAL disappears from the status line of the display.

Overview of MANUAL/ Simulation mode

You can display which outputs and/or controllers are in MANUAL mode.

The device is in "normal display" mode

Press the  key several times for less than 2 seconds (the number of times varies depending on the equipment and configuration of the device).

			MAN.
SWITCH. OUT		----	
ANALOG OUT		----	
CONTROLLER	1+2		MAN.

Output level of controller channels

The device is in "normal display" mode

Press the  key several times for less than 2 seconds (the number of times varies depending on the equipment and configuration of the device).

6 Operation

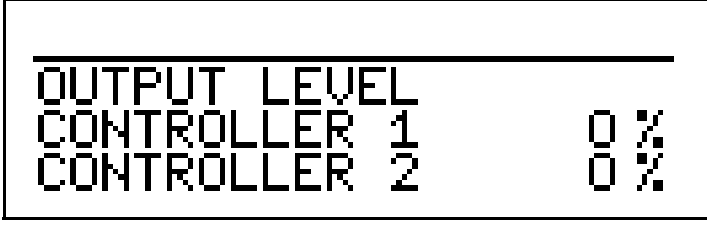

```
OUTPUT LEVEL
CONTROLLER 1    0%
CONTROLLER 2    0%
```

The display changes when the ▲ key or the ▼ key is pressed.



To return to measuring mode:
press the **EXIT** key or wait for a "timeout".





6.7.2 Simulating the switching outputs

Simple witching functions

The switching outputs are configured when the following setting is made:

Operator level / Controller channels 1 and/or 2 / Controller type **Off**

and

Switching output 1 and/or 2 / Function  or  or  or .

Activating the simulation



In the factory setting of the device, the MANUAL mode parameter is set to "No simulation" and can **only be activated by the Administrator!**

This parameter must first be enabled for other users, **See section 6.10.3 "Enable level", page 37.**

* Set Administrator level / Password / Parameter level / Switching output 1 and/or 2 / Manual mode no simulation, **Inactive** or **Active**.

No simulation = No manual mode, control is via the JUMO AQUIS 500.

Inactive = Relay K1 or K2 is de-energized.

Active = Relay K1 or K2 is energized.

Deactivating manual mode

No simulation = No manual mode, control via JUMO AQUIS 500.

6.7.3 Simulation of analog outputs via MANUAL mode

Enabling and activation

- * Select activation of simulation of the actual value output:
Administrator level / Password / Parameter level / Analog output 1 and/or 2 / Simulation / Off or **On**.

With "On", the output takes on the value of the "Simulation value" parameter.
When the JUMO AQUIS is in display mode, the word MANUAL appears in the status line of the display.

Deactivation

- * Administrator level / Password / Parameter level / Analog output 1 and/or 2 / Simulation / Off.

The corresponding output of the JUMO AQUIS 500 works again.
When the JUMO AQUIS is in display mode, the word MANUAL disappears from the status line of the display.

6.7.4 MANUAL/Simulation overview

You can display which outputs and/or controllers are in MANUAL mode.
The device is in "normal display" mode

Press the  key several times for less than 2 seconds (the number of times varies depending on the equipment and configuration of the device).

		MAN.
SWITCH. OUT		----
ANALOG OUT	1+2	MAN.
CONTROLLER		----



To return to measuring mode:
press the  key or wait for a "timeout".

6 Operation

6.8 HOLD mode

In the HOLD state, the outputs take on the states programmed in the relevant parameter (controller channel, switching output or analog output).

This function can be used to "freeze" the switching outputs and the analog outputs of the device. This means the current status of the output will be retained even when the measurement value changes. Control is not via the device.





If MANUAL mode is activated while HOLD mode is activated, MANUAL mode takes precedence and MANUAL then appears in the status line of the display! MANUAL mode can be terminated by pressing the  key.



If HOLD mode is still activated (by the binary input or via the keypad), the device then returns to HOLD mode!

HOLD mode can be activated by pressing the key or by the binary input.

Activation by pressing a key

- * Press and hold the  and  keys longer than 3 seconds. Then the outputs of the device respond according to the default settings. The word HOLD appears in the status line of the display.
-





If the  and  keys are pressed for less than 3 seconds, the device goes into Manual mode.

Then the outputs of the device respond according to the default settings.

Pressing a key to deactivate HOLD mode

- * Press the  and  keys for longer than 3 seconds.
-



If the  and  keys are pressed for less than 3 seconds, the device goes into Manual mode.

Then the outputs of the device respond according to the default settings.

Control is through the outputs of the device again. The word MANUAL disappears from the status line of the display.

6.9 Operator level

All the parameters that the Administrator (**See section 6.10 "Administrator level", page 35**) has enabled can be edited at this level. All the other parameters (marked with a key **T**) are read only.

- * Press the **PGM** key for longer than 2 seconds.
- * Select "OPERATOR LEVEL".



6.10 Administrator level

- All the parameters can be edited at this level.
- At this level, it is also possible to define which parameters can be edited by a "normal" operator and which calibrations can be performed.

To get to the Administrator level, proceed as follows:

- * Press the **PGM** key for longer than 2 seconds.
- * Use the **▼** or **▲** keys to select "ADMINISTR. LEVEL".
- * Use the **▼** or **▲** keys to enter the password 300.
- * Confirm the **PGM** key.

6 Operation

6.10.1 The levels of Administrator level

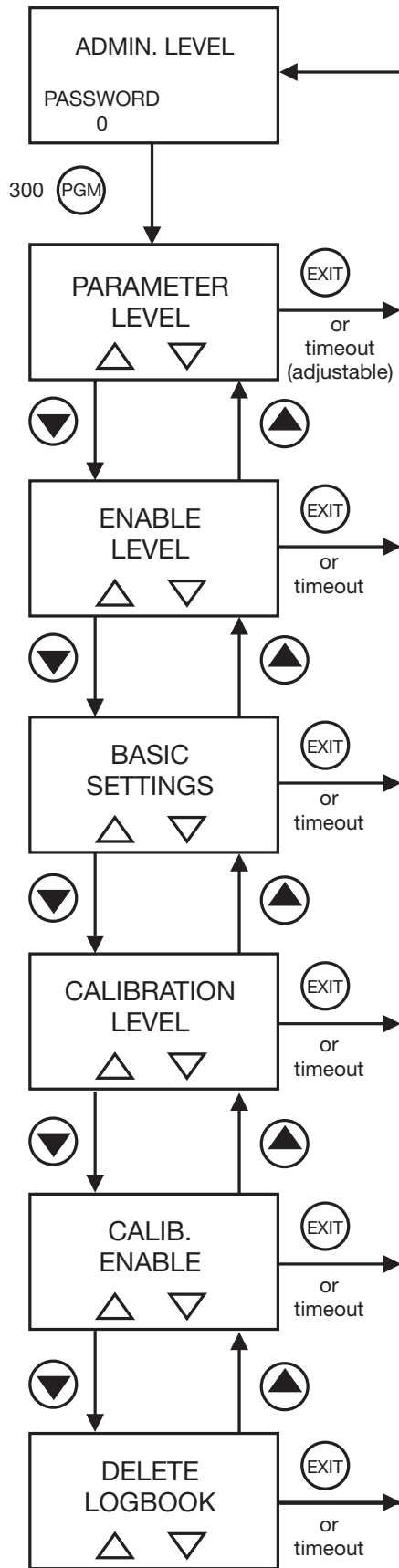

6.10.2 Parameter level

The settings that can be made here are the same as those at operator level, See section 6.9 "Operator level", page 35.

As the operator has administrator rights here, the parameters that are locked at operator level can now also be modified.

6.10.3 Enable level

All parameters can be enabled (editing possible) or locked (editing not possible) for editing here.

All the possible parameters are listed below; depending on the configuration, some of these parameters will not be displayed on the device.

CONDUCT. INPUT (conductivity input)

- Relative cell constant
- Mounting factor
- Zero point
- Compensation type
- Temperature coefficient
- Reference temperature
- Filter time constant
- Calibration interval

TEMPERATURE INPUT

- Sensor type
- Unit
- Manual temperature
- Filter time constant
- Offset

BINARY INPUT

- No function
- Key lock
- Hold mode
- Inverse Hold mode
- Alarm stop

CTRL. CHAN. 1 and CTRL. CHAN. 2

- Controller type
- Setpoint
- Min/max contact
- Proportional band
- Reset time
- Derivative time
- Pulse period
- Min. ON time
- Output level limit
- Max. pulse frequency
- Hysteresis
- Pull-in delay
- Drop-out delay

6 Operation

Controller alarm
 In Hold mode
 On error
 Max. actual value
 Min. actual value

CTRL. SPEC. FUNCT. (special controller function)

I switch-off
 separate controllers
 Manual mode

SWITCH OUTPUT 1 and SWITCH OUTPUT 2

Function
 Switching point
 USP pre-alarm
 Spacing
 Hysteresis
 Switch-on delay
 Switch-off delay
 Pulse time
 During calibration
 Response on error
 Response in Hold mode
 Response in Manual mode
 Break/make contact

ANALOG OUTPUT 1 and ANALOG OUTPUT 2

Signal type
 Scaling start
 Scaling end
 During scaling
 On error
 In Manual mode
 Safe value
 Simulation
 Simulation value
 Signal selector

Output	Analog process value output		Continuous controller main value
	Main variable	Temperature	
1	X	-	X
2	-	X	X

DISPLAY

Language
 Lighting
 LCD inverse
 Meas. display type
 Lower display
 Upper display
 Bar graph calibration start

Bar graph calibration end
 MIN/MAX reset
 Operator timeout
 Contrast

WASH TIMER Cycle duration
 Wash duration

6.10.4 Basic settings

The device has a basic settings wizard, to make it easier for the user to configure the extensive conductivity and standard signal input setting options and to avoid configuration conflicts. Here all the important settings are systematically queried. At the end, once a request for conformation has been acknowledged, the device is initialized with the new settings. Dependent parameters are checked and adjusted.

6.10.5 Basic settings wizard

The basic settings of the device are specified at this level. Parameters are modified using keys \blacktriangledown and \blacktriangle . Use the $\boxed{\text{PGM}}$ key to select the next parameter.

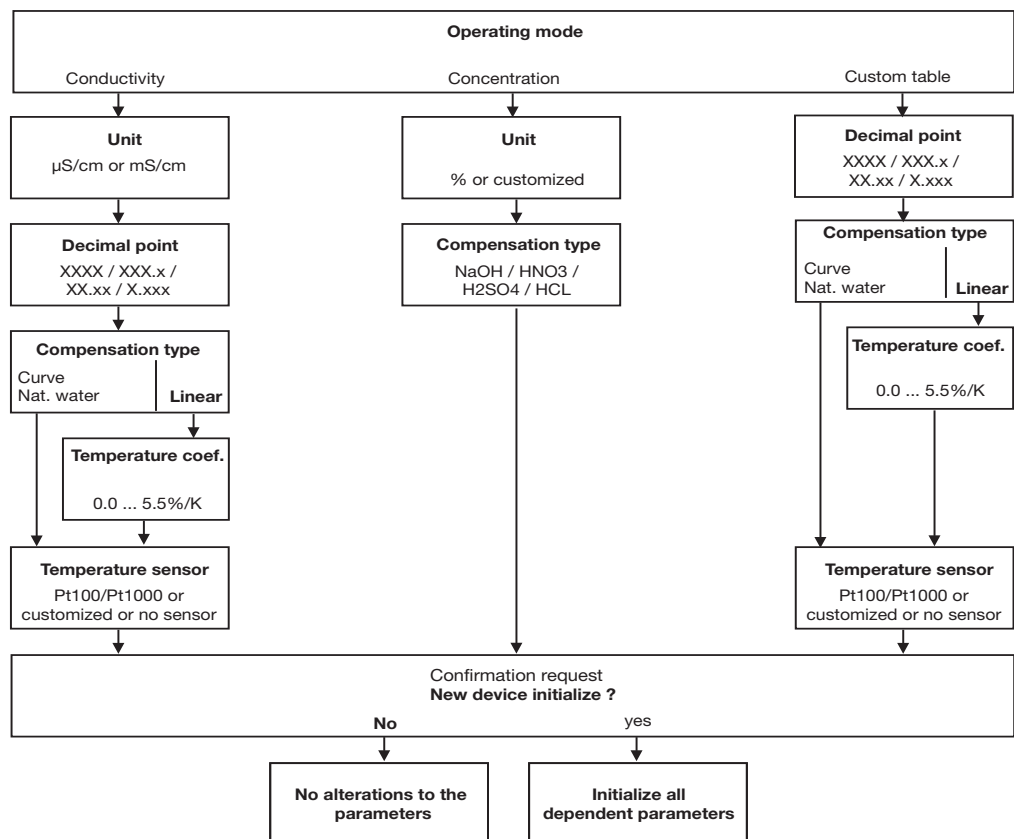

6 Operation

6.10.6 Calibration level

Three calibration options are provided:

- Linear temperature coefficient
- Non-linear temperature coefficient (temp. coef. curve)
- Relative cell constant

The calibration level is reached via: ADMINISTR. LEVEL / PASSWORD / CALIB. LEVEL.

6.10.7 Calibration enable

Here you can set whether or not the start of the calibration procedure is enabled at the operator level or by the "CAL" key.

Calibration enable is reached via: ADMINISTR. LEVEL / PASSWORD / CALIB. ENABLE.

The following can be locked or enabled:

- Linear temperature coefficient
- Non-linear temperature coefficient (temp. coef. curve)
- Relative cell constant

6.10.8 Delete logbook

The last five calibration processes are archived in the calibration logbook.

If required, the logbook can be deleted once a request for confirmation has been acknowledged.

6.11 Device info

Here is a list of the current configuration of all the important parameters (from the Basic Settings menu).

Example	CELL CONSTANT	-> 5.15
	OPERATING MODE	-> CONDUCTIVITY
	UNIT	-> mS/cm
	DECIMAL POINTS	-> XXXX
	COMPENSATION TYPE	-> LINEAR
	TEMPERATUR COEFF.	-> 2.20%/K

6.12 Controller functions

Simple witching functions

In the JUMO AQUIS 500, simple switching functions (AF) such as alarm contacts, limit value monitoring or calibration timer signaling are configured at parameter level via the parameters of "Switching outputs 1 and 2".









The parameters of controller channels 1 and 2 must then be set to "Off"!

Higher order control functions

Higher order control functions are configured at parameter level via the parameters of "Controller channels 1 and 2".

The parameters of the controller channels must then be set to "Controller 1 and Controller 2"!

Operator level parameters

Switching output 1 / 2	Explanation
none	No switching function and no control function required
Controller 1	device control should be of a "higher order"
Controller 2	device control should be of a "higher order"
Controller alarm 1 / 2 Controller alarm	"Simple" switching functions
 Main var.	AF1 main variable
 Main var.	AF2 main variable
 Main var.	AF7 main variable
 Main var.	AF8 main variable
 Temp.	AF1 temperature
 Temp.	AF2 temperature
 Temp.	AF7 temperature
 Temp.	AF8 temperature
Sensor error Calib. timer Autorange USP USP pre-alarm PH. EUR PH. EUR pre-al.	
Controller channel 1 / 2	
Limit Pulse width Pulse frequency Continuous Modulating	"Higher order" control functions
Off	Must be selected if "simple" switching functions are required.

7 Startup

7.1 Getting started



The B 202566.0.1 calibration instructions must be used to coordinate the JUMO AQUIS 500 Ci transmitter and the inductive conductivity sensor!

The calibration instructions are included with the type 202711/21 calibration adapter option. Needed for the adaptation are:

the JUMO AQUIS 500 Ci transmitter/controller, data sheet 202566

an inductive conductivity and temperature sensor, data sheet 202941, 202942 or 202943

a type 202711/21 calibration adapter for inductive conductivity measurement, data sheet 202711



Below is a suggestion for configuring the device reliably in little time.

By checking the setting options of this list before starting the configuration, you can avoid timeouts during the configuration.

- * Mount the JUMO AQUIS 500 Ci transmitter/controller, See section 4 "Mounting", page 11
- * Mount the JUMO tecLine Ci inductive conductivity and temperature sensor, see installation instructions B 20.2941.4 .
- * Install both devices, See section 5 "Electrical connection", page 16 ff.
- * Call up Administrator level (ADMINISTR. LEVEL).
- * Enter password 300.
- * Call up PARAMETER LEVEL / DISPLAY / OP. TIMEOUT.
- * Set OP. TIMEOUT to 0 minutes (no timeout).
- * Exit the Parameter level.
- * Call up Administrator level (ADMINISTR. LEVEL).
- * Enter password 300.
- * Select BASIC SETTINGS and work through all the menu items.
- * Answer "YES" to the "New device initialize" query.
- * Configure the required parameters.
- * Calibrate the device to the sensor and the sample medium, See section 8 "Calibrating inductive conductivity cells", page 48.

7.2 Setting example

7.2.1 Measurement in the food industry with an hygienic inductive conductivity and temperature sensor (PEEK)

Task	Measurement range:	0 - 1.00 mS/cm
	Display:	two decimal places
	Cell constant K:	5.15 1/cm (see printing on cell)
	Output signal:	4 - 20 mA
	Temperature compensation:	linear
	Temperature measurement	automatic (sensor is incorporated in the cell)
	Control function:	limit controller, max. function
	Limit:	600 μ S/cm corresponding to 0.6 mS/cm

Calling up Administrator level

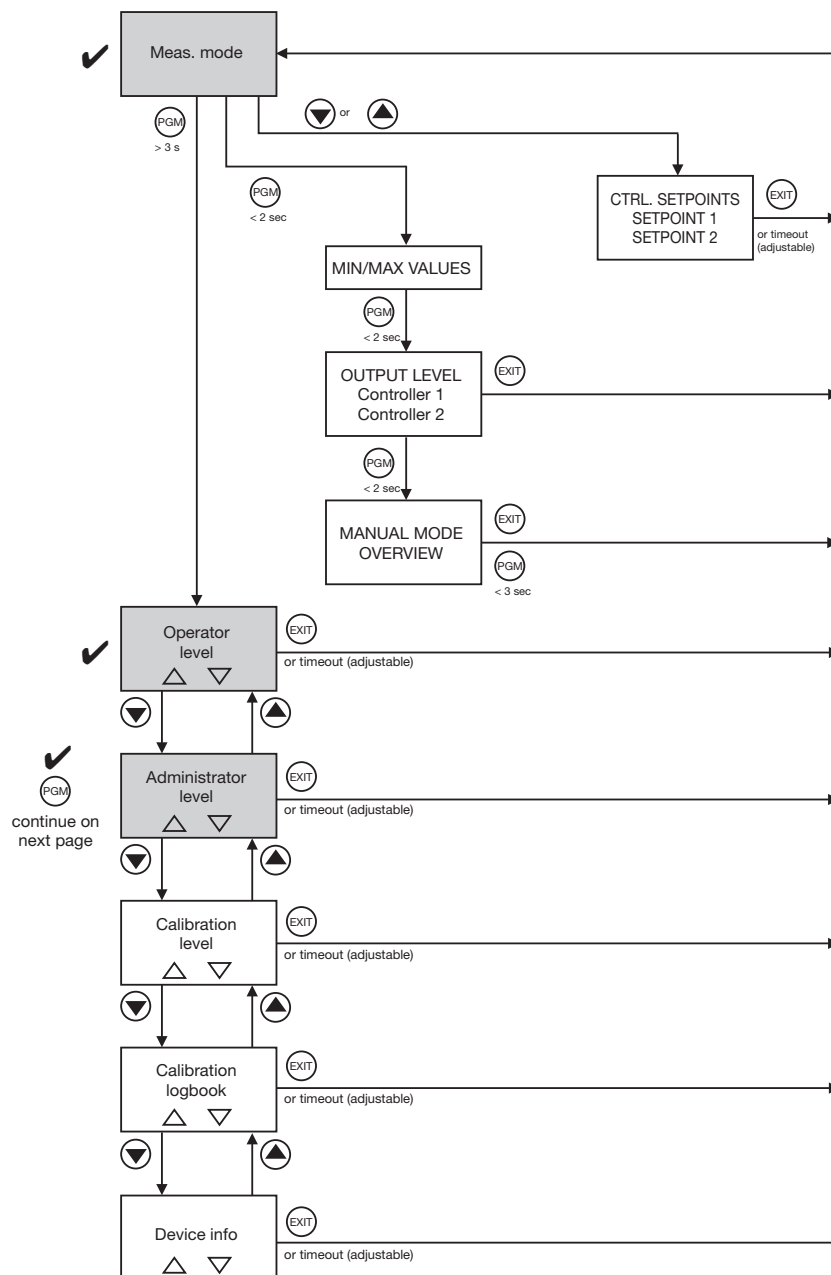

7 Startup

Calling up the basic settings

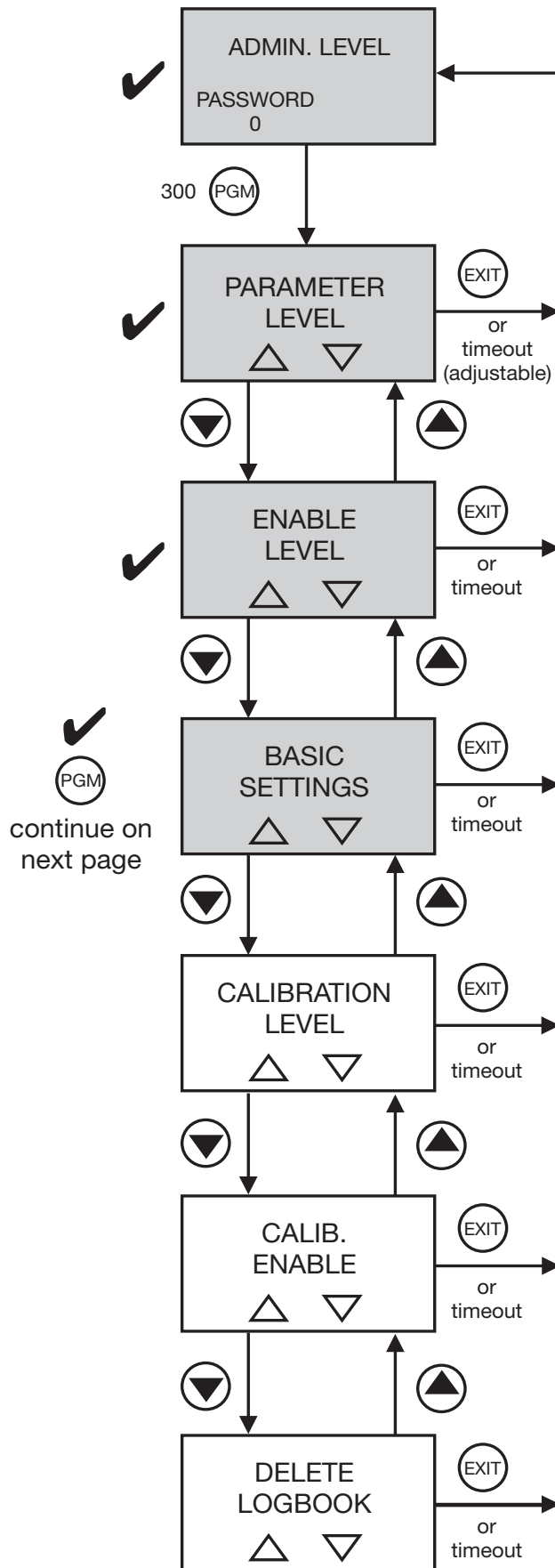

Making the basic settings for the main input

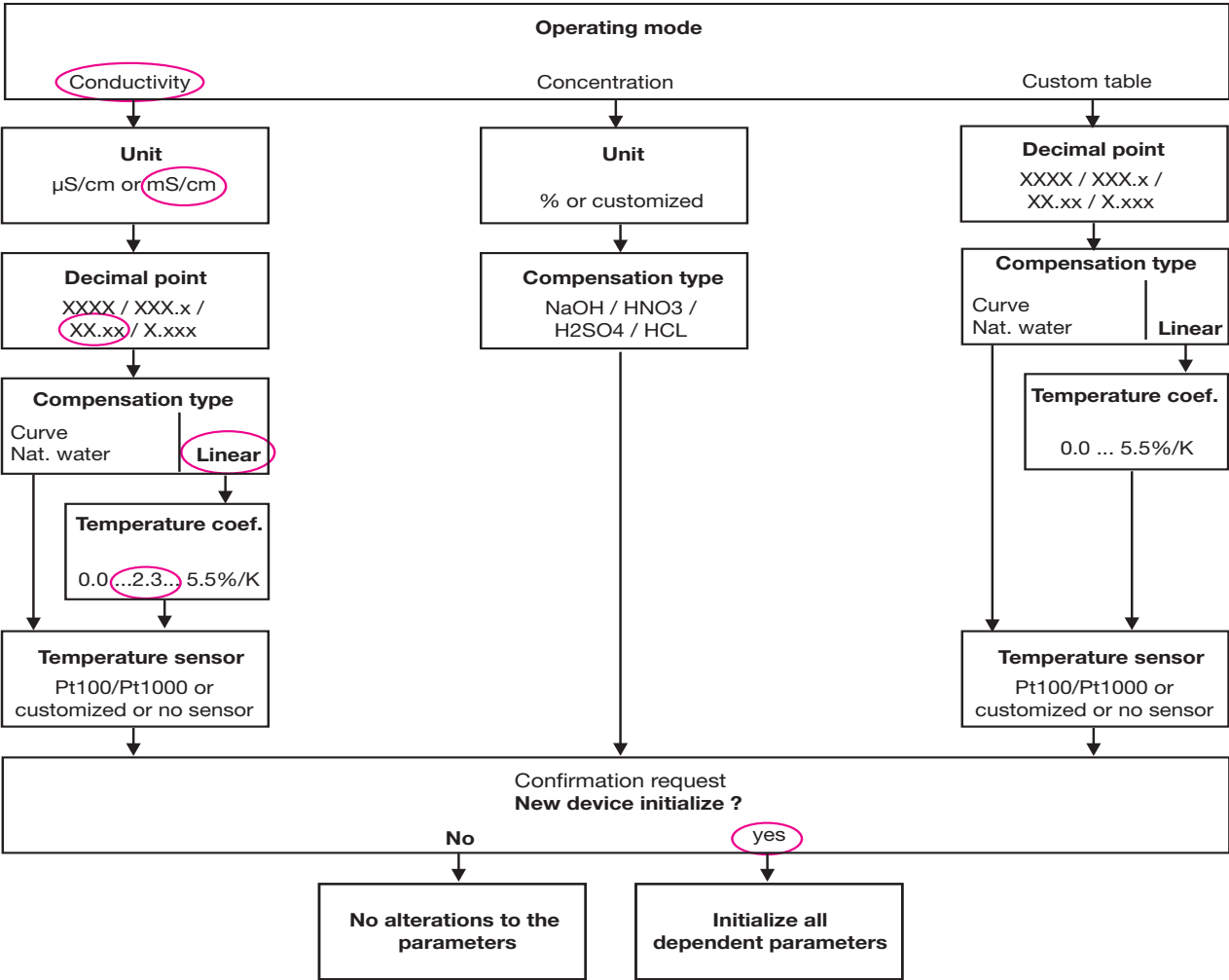

Concluding device settings

Input for temperature	Sensor type:	Pt100/Pt1000
	Unit:	°C
	Filter time constant:	00:00:02
	Offset:	0.0°C
Controller channel 1	Controller type:	limit
	Setpoint:	0.60 mS/cm
	Min./max. contact:	as required
	Hysteresis:	as required
	Pull-in delay:	as required
	Drop-out delay:	as required
	Controller alarm:	as required
	In Hold mode:	as required
	On error:	as required
	Max. setpoint:	as required
	Min. setpoint:	as required
Controller channel 2	Controller type:	OFF
Switching output 1	Function:	controller 1
Switching output 2	Function:	no function
Analog output 1	Signal selector:	main variable
	Signal type:	4 - 20 mA
	Scaling start:	0.00 mS/cm
	Scaling end:	1.00 mS/cm

8 Calibrating inductive conductivity cells

8.1 Notes



During calibration, relays and analog output signals adopt their configured states!



The sensors connected to the device should be cleaned and the device itself calibrated, at regular intervals (subject to the medium).

8.2 General

Calibration options

The device provides three calibration options for adapting the JUMO AQUIS 500 Ci to the sensor and the medium:

- Calibration of the relative cell constants; this is a one-point calibration, See section 8.3 "Calibrating the relative cell constant", page 49.
 - Calibration of a linear temperature coefficient; this is a two-point calibration, See section 8.4 "Calibrating the temperature coefficient of the measurement solution", page 51.
 - Calibration of a non-linear temperature coefficient. The temperature coefficient is calibrated at six points here, See section 8.4 "Calibrating the temperature coefficient of the measurement solution", page 51.
-

Starting calibration

Calibration can be started as follows:

- By pressing the  key, if this has been enabled in ADMINISTR. LEVEL / PASSWORD / CALIB. ENABLE.
 - via ADMINISTR. LEVEL / PASSWORD / CALIB. LEVEL.
 - via CALIB. LEVEL, if this has been enabled in ADMINISTR. LEVEL / PASSWORD / CALIB. ENABLE.
-



During calibration, the active component of the inductive conductivity sensor must not be allowed to touch the floor or the wall of the vessel (comply with the minimum distance as per the inductive sensor operating instructions).

8 Calibrating inductive conductivity cells

8.3 Calibrating the relative cell constant

When there is an increased demand for accuracy, the cell constant first has to be calibrated.

Requirement

- The JUMO AQUIS 500 Ci must be supplied with voltage.
See section 5 "Electrical connection", page 16 ff.
- A conductivity sensor must be connected.
- The configuration of the basic settings must be as follows:
SIGNAL TYPE relevant to the connected transmitter
OPERATING MODE "CONDUCTIVITY"
UNIT mS/cm or μ S/cm
DECIMAL POINT as required
SCALING START ¹
SCALING END ¹
.
- Calibration must be enabled,
See section 6.10 "Administrator level", page 35.
- The transmitter is in "measuring mode".

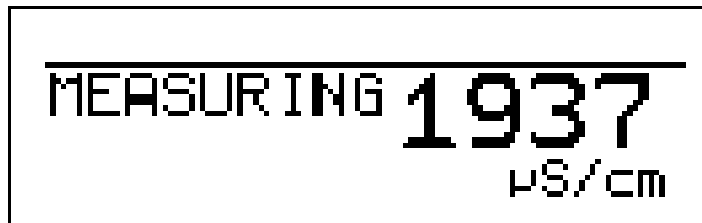

The measurement solution must maintain a constant temperature during calibration!

- * Press the key or
select the calibration level (CALIB. LEVEL) or
at Administrator level (password required), select the calibration level.
- * Immerse the conductivity sensor in a reference solution with a known conductivity.

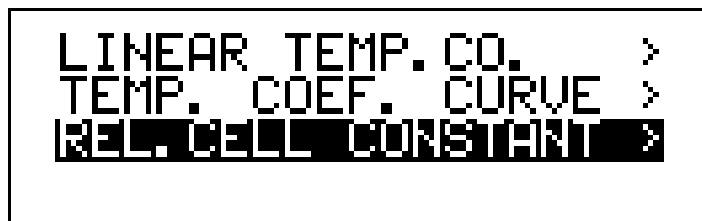

- * Select REL. CELL CONSTANT;
- * Press the key.

8 Calibrating inductive conductivity cells

CALIB	
MEAS.	1938
REFERENCE	$\mu\text{S}/\text{cm}$
	25.0 °C

- * When the measurement value is steady, press the **PGM** key; the displayed conductivity measurement flashes.

CALIB	
ENTRY	2000
REFERENCE	$\mu\text{S}/\text{cm}$

- * Use the **▼** or **▲** keys to set the value to the actual conductivity.
- * Press the **PGM** key; the relative cell constant determined by the device is displayed (as a %).

CALIB	
CELL CONST	103.3 %

- * Use the **PGM** key to accept the temperature coefficient or the **EXIT** key to reject it.

MEASURING	2000
	$\mu\text{S}/\text{cm}$

The current measurement value and the temperature are displayed.

8 Calibrating inductive conductivity cells

8.4 Calibrating the temperature coefficient of the measurement solution

8.4.1 Linear temperature coefficient

The conductivity of each measurement solution changes in accordance with its specific temperature coefficient.

We therefore recommend that you run a temperature coefficient calibration.

Requirement

- The JUMO AQUIS 500 Ci must be supplied with voltage.
See section 5 "Electrical connection", page 16 ff.
- A conductivity sensor must be connected.
- A temperature sensor must be connected.
- The configuration of the basic settings must be as follows:
SIGNAL TYPE relevant to the connected transmitter
OPERATING MODE "CONDUCTIVITY"
UNIT mS/cm or μ S/cm
DECIMAL POINT as required
SCALING START
SCALING END
.
- Calibration must be enabled,
See section 6.10 "Administrator level", page 35.
- The transmitter is in "measuring mode".

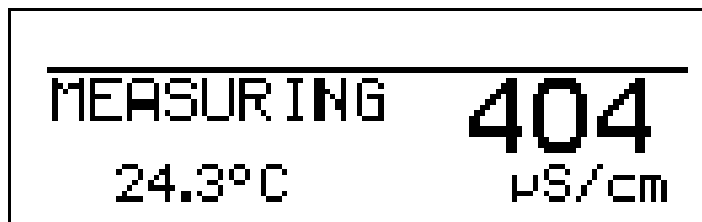

MEASURING 404
24.3°C μ S/cm

- * Immerse the conductivity sensor in a sample of the measurement solution.
- * Press the key or
select the calibration level (CALIB. LEVEL) or
at Administrator level (password required), select the calibration level.
- * Select "LINEAR TEMP. CO."

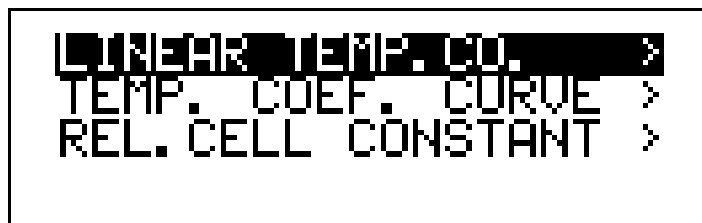

LINEAR TEMP. CO. >
TEMP. COEF. CURVE >
REL. CELL CONSTANT >

8 Calibrating inductive conductivity cells

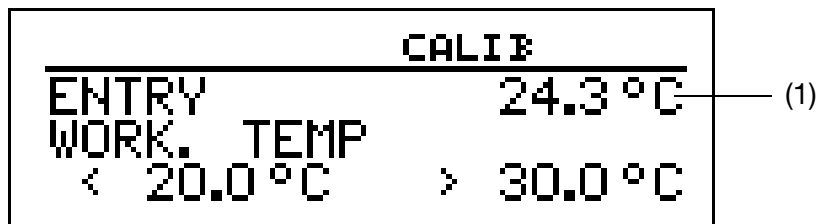

The displayed current sensor temperature flashes (1).

* Enter the required working temperature and confirm your entry.



The working temperature must be at least 5°C above or below the reference temperature (25.0°C).

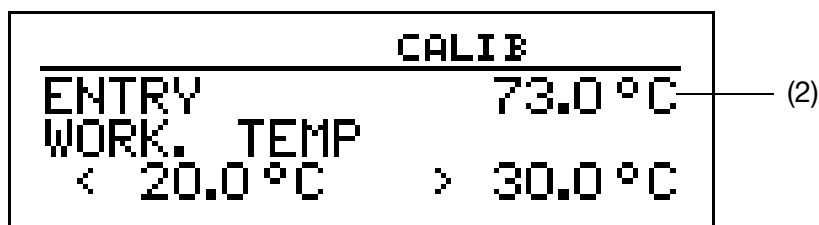

The LC display now shows the chosen working temperature (flashing) (2).

* Press the  key.

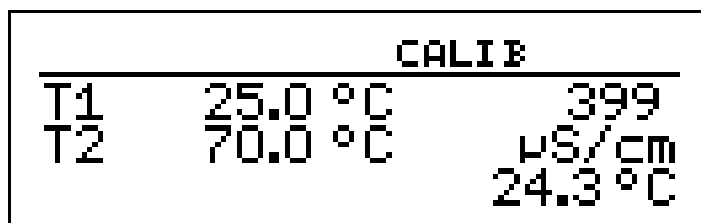

The conductivity (399 μS/cm) at the current temperature (24.3°C) now appears on the right of the LC display.

The temperatures T1 (25°C) and T2 (70.0°C) that have yet to be triggered, are shown on the left.

* Press the  key.

* Heat the medium until the working temperature is reached.



During calibration, the rate of temperature change in the measurement solution must not exceed 10 °C/min.



Calibration is also possible in the cooling process (with a falling temperature). It starts above the working temperature and ends below the reference temperature.

8 Calibrating inductive conductivity cells

As soon as the temperature of the medium exceeds T1 (25°C), this is hidden on the display. The uncompensated conductivity at the current temperature is displayed on the right.

CALIB		
T2	73.0 °C	800 µS/cm 74.3 °C

If the temperature of the medium exceeded T2 (73.0°C), the device determines the temperature coefficient.

The LC display now shows the determined temperature coefficient as %/°C.

CALIB	
TEMP. COEF.	1.99 %

- * Use the key to accept the temperature coefficient or the key to reject it.

MEASURING	405
74.2°C	µS/cm

The transmitter is in "measuring mode" and displays the compensated conductivity of the solution.

8 Calibrating inductive conductivity cells

8.4.2 Non-linear temperature coefficient (TEMP. COEF. CURVE)



The non-linear temperature coefficient can **only** be calibrated with a rising temperature!

The start temperature **must be below** the configured reference temperature (usually 25°C)!

The "Temp. coef. curve" menu item is only displayed when a temperature sensor is connected: "TEMPERATURE INPUT/ Pt100/Pt1000".

The conductivity of each measurement solution changes in accordance with its specific temperature coefficient.

We therefore recommend that you run a temperature coefficient calibration.

Requirement

- The JUMO AQUIS 500 Ci must be supplied with voltage.
See section 5 "Electrical connection", page 16 ff.
- A conductivity sensor must be connected.
- A temperature sensor must be connected.
- The configuration of the basic settings must be as follows:
SIGNAL TYPE relevant to the connected transmitter
OPERATING MODE "CONDUCTIVITY"
UNIT mS/cm or μ S/cm
DECIMAL POINT as required
SCALING START
SCALING END
.
- Calibration must be enabled,
See section 6.10 "Administrator level", page 35.
- The transmitter is in "measuring mode".

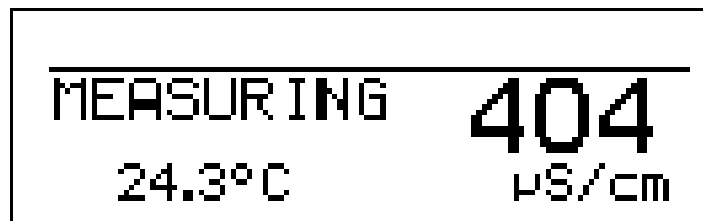

- * Immerse the conductivity sensor in a sample of the measurement solution.
- * Press the key or
select the calibration level (CALIB. LEVEL) or
at Administrator level (password required), select the calibration level.

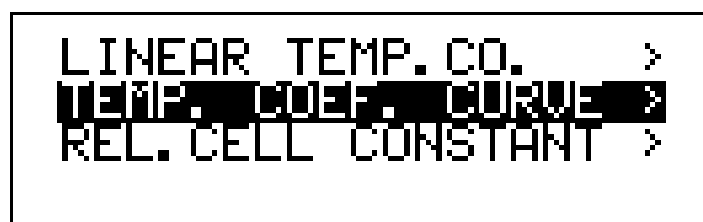

8 Calibrating inductive conductivity cells

- * Select "TEMP. COEF. CURVE " and press the  key.

```
          CALIB
-----
ENTRY          24.0 °C (1)
TEMP. BEGIN
```

Enter the required start temperature (1) for the temp. coef. curve.

```
          CALIB
-----
ENTRY          75.0 °C (2)
TEMP.  END
```

- * Enter the required end temperature (2) for the temp. coef. curve.

```
          CALIB
-----
NEXT          39.15 (3)
TEMP.         mS/cm
(5) 24.0 °C   21.1 °C (4)
```

- * Heat the medium continuously
 - (3) the current uncompensated conductivity
 - (4) the current temperature of the medium
 - (5) the first target temperature





During calibration, the rate of temperature change in the measurement solution must not exceed 10 °C/min.

During the calibration process, the device displays values for the following five temperature interpolation points.

The end temperature has been reached

The LC display now shows the determined temperature coefficients as %/°C.

```
          CALIB
-----
1: 3.91 %/K  2: 3.67 %/K
3: 3.35 %/K  4: 3.12 %/K
5: 2.87 %/K  6: 2.51 %/K
```

- * Use the  key to accept the temperature coefficients or the  key to reject the calibration result.

8 Calibrating inductive conductivity cells

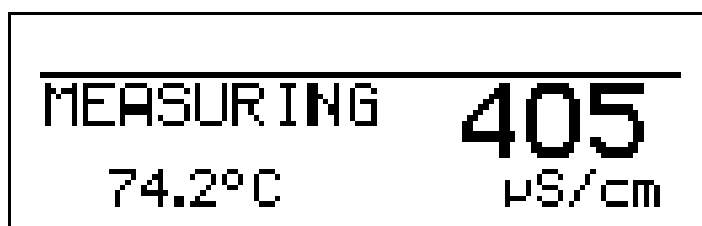

The transmitter is in "measuring mode" and displays the compensated conductivity of the solution.

8 Calibrating inductive conductivity cells

8.5 Calibration logbook

The results of the last successful calibration are documented in the calibration logbook.

```
OPERATOR LEVEL > |
ADMINISTR. LEVEL > |
CALIB. LEVEL > |
CALIB. LOGBOOK > |
```

```
CELL CONST 102.9 % |
TEMPCO. 2.0 %/K |
TEMP. 1 74.3 °C |
TEMP. 2 24.3 °C |
```

- Relative cell constant (CELL CONST) = 102.9%.
- Temperature coefficient of the sample medium = 2.0%/°C.
- The temperature coefficient was determined at temperatures T1 and T2.

It is not possible to assign a time.



9 Setup program

9.1 Function

Configurable parameters

Both the setup program and the PC interface cable with USB/TTL converter (70/00456352) are available as options, and provide a convenient way to adapt the JUMO AQUIS Ci to meet requirements:

- Setting the measuring range.
- Setting the response of the outputs to an overrange signal.
- Setting the functions of switching outputs K1 and K2.
- Setting the functions of binary input E1.
- Setting special functions (e.g. operating mode, controller).
- Setting a customized characteristic
- etc.



Data can only be transferred from or to the transmitter if it is supplied with voltage, See section 5 "Electrical connection", page 16ff.

Connection

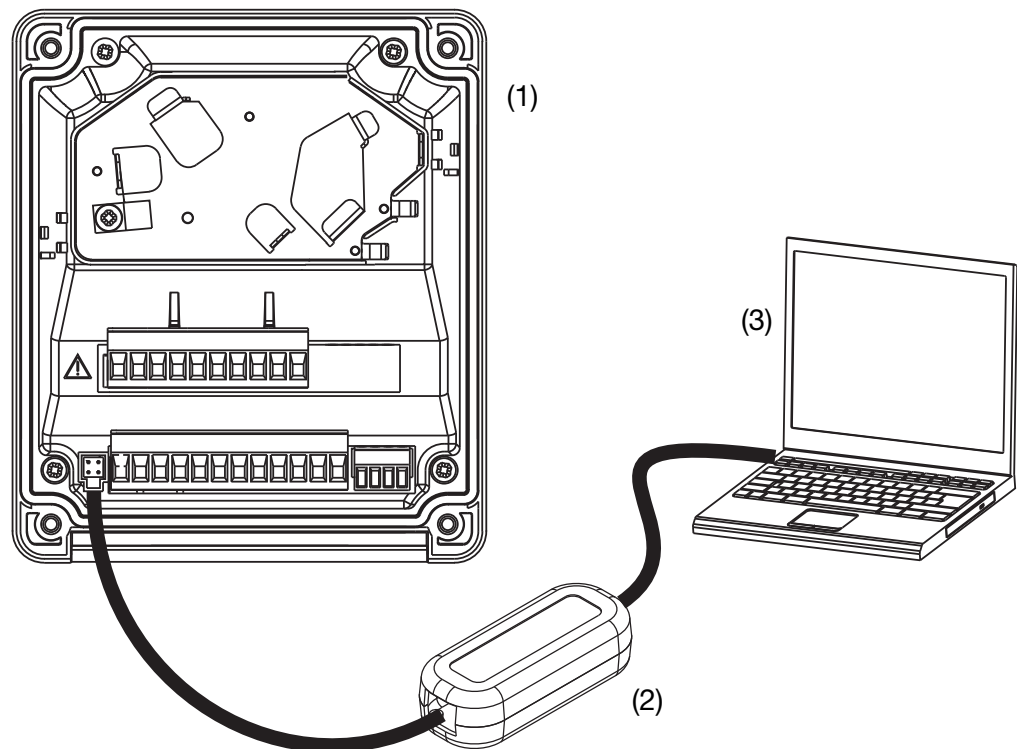

- (1) JUMO AQUIS 500 Ci
- (2) PC interface cable with USB/TTL converter, part no.: 00456352
- (3) PC or Notebook

10 Eliminating errors and faults

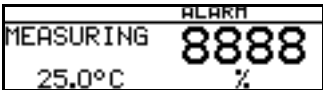
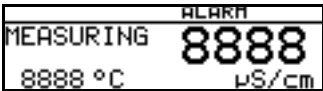
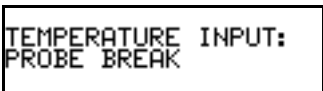
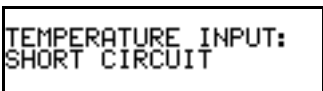
Problem	Possible cause	Action
No measurement display or current output	There is no power supply	Check the power supply
Measurement display 0000 or current output 4 mA	Sensor not immersed in medium; level in container too low	Top up the container
	Flow-through fitting is blocked	Clean the flow-through fitting
	Sensor is faulty	Replace the sensor
Incorrect or fluctuating measurement display	Sensor positioning incorrect	Choose another installation location
	Too little sensor to wall distance	Choose another installation location, Compensation via the "mounting factor" -> PARAMETER LEVEL / CONDUCT. INPUT. / MOUNTING FACTOR
	No mixing	Ensure proper mixing. Make sure sensor is washed all-round
	Air bubbles	Optimize the mounting
Measurement display 8888, temperature display "ok", flashing 	Overrange	Choose a suitable measuring range
Measurement display 8888, temperature display 8888 flashing 	Temperature is overrange or underrange	Temperature of medium must be within the permitted range. Replace the sensor. Send the device away for repair.
	Temperature probe short-circuit or interruption	Replace sensor and/or cable. Send the device away for repair.
	Broken lead	Replace sensor and/or cable
	No sensor connected	Connect a sensor. Configure the sensor on the device.
	Short-circuit - cable - sensor - terminals	Check cable and connections. Replace sensor.

10 Eliminating errors and faults

TEMPERATURE INPUT: OVERRANGE	Temperature is too high	Keep to the permitted range
Problem	Possible cause	Action
TEMPERATURE INPUT: UNDERRANGE	Temperature is too low	Keep to the permitted range
MAIN VAR. INPUT: UNDERRANGE	Input signal is too low	Check the sensor Check the "zero point" parameter
MAIN VAR. INPUT: OUT OF RANGE	Concentration is outside the permitted range	Check the concentration
MAIN VAR. INPUT: OVERRANGE	Input signal is too high	Check the sensor Check the measuring range
COMPENSATION RANGE LEFT	Temperature is lower or higher than the compensation range (e.g. greater than 36°C for natural water)	Check the temperature
PARAMETER LOCKED	Parameter is not enabled	Enable the parameter at Enable level
WRONG PASSWORD	Incorrect password	The correct password can be read out with the setup program
KEYS LOCKED	Key lock has been activated through the binary input	Override binary input activation

11 Technical data

11.1 Main input conductivity

Measuring range	0000 - 9999 $\mu\text{S/cm}$ 0.000 - 9.999 mS/cm 0.00 - 99.99 mS/cm 0.0 - 999.9 mS/cm 0 - 2000 mS/cm		
Accuracy¹ 0.000 - 1.000 mS/cm 1.01 - 500 mS/cm 501 - 2000 mS/cm	1.5% of span 1% of span 1.5% of span		
Operating mode Concentration measurement			
NaOH caustic solution	Range 1:	0 - 12 % by weight	(0 - 90°C)
	Range 2:	20 - 50 % by weight	(0 - 90°C)
HNO3 nitric acid	Range 1:	0 - 25 % by weight	(0 - 80°C)
	Range 2:	36 - 82 % by weight	(0 - 80°C)
H2SO4 sulphuric acid	Range 1:	0 - 28 % by weight	(0 - 90°C)
	Range 2:	36 - 85 % by weight	(0 - 90°C)
	Range 3:	92 - 99 % by weight	(0 - 90°C)
HCL hydrochloric acid	Range 1:	0 - 18 % by weight	(0 - 65°C)
	Range 2:	22 - 44 % by weight	(0 - 65°C)
Operating mode Customized table	The temperature compensated conductivity is converted to a new display value with a table. The table can contain as many as 20 value pairs. The display unit can also be adapted. Process sequence: Uncompensated conductivity > Temperature compensation > Linearization with table > Display value.		

¹ Effect of temperature on the JUMO AQUIS 500 Ci with inductivity conductivity probe JUMO tecLINE Ci. Variation from 22°C relative to the final output signal value 0(4) - 20 mA and 0 -10 V.

11.2 Secondary input temperature

Pt100 (automatic detection)	
Measuring range	-50 to 250°C
Accuracy	$\pm 0,5_K$ (up to 100 °C); $\pm 0,8_K$ (as of 100 °C)
Ambient temperature error	0.05 %/10°C
Pt1000 (automatic detection)	
Measuring range	-50 ... 250°C
Accuracy	$\pm 0,5_K$ (up to 100 °C); $\pm 1,0_K$ (as of 100 °C)
Ambient temperature error	0,05 %/10K

11 Technical data

NTC / PTC	
Measuring range	max. 4 kΩ Input of a table with up to 20 value pairs via the setup program
Accuracy	≤ 0.3°C (subject to the interpolation points)
Ambient temperature error	0.05 %/10°C

11.3 Temperature compensation

Linear		
TC (α) setting range	0 - 5.5 %/°C	$L_f(\text{compensated}) = \frac{L_f(\text{uncompensated})}{\left(1 + \frac{\alpha}{100}\right) * DT}$ DT = temperature difference to reference temperature (T _{current} - T _{Ref})
Temperature range	0(-10) to 100°C	
Natural water (ISO 7888)		
TC (α) setting range	not applicable	
Temperature range	0 to 36°C	
Reference temperature	adjustable: 15 - 30°C preset to 25°C (default)	

11.4 Measuring circuit monitoring

Conductivity input	
Ovrange/underrange	yes
Short-circuit	
Broken lead	Subject to measuring range Subject to measuring range
Temperature input	
Ovrange/underrange	yes
Short-circuit	yes

11.5 Cell constant

Adjustment range 1	4 to 6 [1/cm]
Adjustment range 2	6 to 8 [1/cm]
Setting range of the relative cell constant	80 - 120%
Mounting factor	80 - 120%

11.6 Binary input

Activation	by floating contact
Function	key lock HOLD alarm suppression

11 Technical data

11.7 Controller

Controller type	alarm functions, limit controller, pulse width controller, pulse frequency controller, modulating controller, continuous controller
Controller structure	P / PI / PD / PID
A/D converter	dynamic resolution up to 14 bits
Sampling time	500 ms

Switching outputs (max. two (SPDT) changeovers)

Rated load	3 A / 250 VAC (resistive load)
Contact life	>2 x 10 ⁵ operations at rated load

11.8 Setup interface

Interface for configuring the device with the available setup program option (for device configuration only).

11.9 Electrical data

Power supply	110 - 240 V AC; -15/+10%; 48 - 63 Hz 20 - 30 V AC/DC; 48 - 63 Hz 12 - 24 V DC +/-15% (permissible only for connection to SELV/PELV circuits)
Power consumption	approx. 14 VA
Electrical safety	to EN 61 010, Part 1 overvoltage category III ¹ , pollution degree 2
Data backup	EEPROM
Electrical connection	
Power supply, relay outputs, sensor inputs	Pluggable screw terminals for max. conductor cross-section 2.5 mm ²
Analog outputs	Pluggable screw terminals, max. conductor cross-section 1.5 mm ²
Inductive conductivity sensor	M12 connection

¹ Not valid for power supply 30, 12 - 24 V DC.

11.10 Display

Graphic LC display	120 x 32 pixels
Backlighting	Programmable: - off - on for 60 seconds during operation

11.11 Housing

Material	ABS
Cable entry	Cable glands, max. 3 x M16 and 2 x M12
Feature	Ventilation element to prevent condensation

11 Technical data

Ambient temperature range (the specified accuracy is adhered to in this range)	-10 to 50°C
Operating temperature range (device operational)	-15 to 65°C
Storage temperature range	-30 to 70°C
Climatic rating	rel. humidity ≤ 90% annual mean, no compensation (based on EN 60721 3-3 3K3)
Enclosure protection to EN 60529	surface-mounted wall housing:IP67 control cabinet mounting:at front IP65, at rear IP20
Vibration resistant	to EN 60068-2-6
Weight	surface-mounted wall housing:approx. 900 g control cabinet mounting:approx. 480 g
Dimensions	See section 4.2 "Surface mounting the transmitter", page 11

11.12 Analog outputs (max. 2)

Output type	Signal range	Accuracy	Temperature error	Permissible load resistance
Current signal	0/4 - 20 mA	≤ 0.25%	0.08%/10 °C	≤ 500 Ω
Voltage signal	0 - 10 V	≤ 0.25%	0.08%/10 °C	≥ 500 Ω

Analog outputs respond in accordance with NAMUR recommendation NE43.
Analog outputs are electrically isolated, 30 V AC / 50 V DC.

11.13 Approvals/marks of conformity

Mark of conformity	Testing laboratory	Certificates/certification numbers	Test basis	valid for
c UL us	Underwriters Laboratories	E 201387	UL 61010-1	all types

12.1 Operator level parameters

When there are numerous device parameters to configure, it is advisable to make a note in the table below of all the parameters to be changed and to work through these parameters in the given order.



The following list shows the maximum number of parameters that can be modified.

Some of these parameters will not be visible (and therefore not editable) for your particular device, depending on the configuration.

Parameter	Selection / value range factory setting	New setting
Conductivity input		
Temperature coefficient	0 - 2.2 - 5.5%/°C	
Relative cell constant	80 - 100 - 120%	
Mounting factor	80 - 100 - 120%	
Zero point	Conductivity: -20 to 0 to +20% of range	
Decimal point (via basic setting only)	XXXX XXX.x XX.xx X.xxx	
Compensation type	Conductivity measurement operating mode - Linear - Temp. coef. curve - Natural water Concentration measurement operating mode - NaOH 0 - 12 % by weight - NaOH 20 - 50 % by weight - HNO3 0 - 25 % by weight - HNO3 36 - 82 % by weight - H2SO4 0 - 28 % by weight - H2SO4 36 - 85 % by weight - H2SO4 92 - 99 % by weight - HCl 0 - 18 % by weight - HCl 22 - 44 % by weight	
Reference temperature	15.0 - 25.0 - 30.0°C	
Filter time constant	0 to 25 s	
Calibration interval	0 - 999 days (0 = off)	
Temperature input		
Sensor type	Pt100/Pt1000 Customized Manual temperature entry	
Unit	° C °F	
Filter time constant	0 - 2 - 25 s	
Manual temperature entry	-50.0 to 25.0 to 250.0°C	
Offset	-20.0 to 0.0 .to +20.0°C	
Binary input		

12 Appendix

Parameter	Selection / value range factory setting	New setting
Function	No function Key lock Hold mode Hold mode inverse Alarm stop (for controller only)	
Controller channel 1		
Controller type	No function Limit controller Pulse frequency output Pulse width output Continuous controller Modulating controller	
Setpoint	According to device variant	
Second setpoint (modulating controller at controller 1 only)	According to device variant	
Min. / max. contact	Min. contact Max. contact	
Proportional band	0 - 9999 (configurable decimal places)	
Reset time	0 - 9999	
Derivative time	0 - 9999	
Pulse period	2.5 - 20 - 999.5	
Actuator stroke time (modulating controller at controller 1 only)	15 - 60 - 3000 s	
Hysteresis (of limit controller)	0 - 200 - 9999 (configurable decimal places)	
Minimum ON time	0.5 - 999.5	
Maximum pulse frequency	0 - 60 1/min.	
Output level limit	0 - 100%	
Pull-in delay	0.00 - 999.5 s	
Drop-out delay	0.00 - 999.5 s	
Limit controller monitoring	Off On	
Alarm tolerance	0 - end of range	
Alarm delay	0 - 9999 s	
Response during Hold	0% 100 Frozen Hold value	
Hold value	0 - 100%	
Response on error	0% 100% Frozen Hold value	
Min. setpoint limit	0 - 9999 (configurable decimal places)	
Max. setpoint limit	0 - 9999 (configurable decimal places)	

12 Appendix

Parameter	Selection / value range factory setting	New setting
Controller channel 2		
Controller type	No function Limit controller Pulse frequency output Pulse width output Continuous controller	
Setpoint	According to device variant	
Second setpoint (modulating controller at controller 1 only)	According to device variant	
Min. / max. contact	Min. contact Max. contact	
Proportional band	0 - 9999 (configurable decimal places)	
Reset time	0 - 9999	
Derivative time	0 - 9999	
Pulse period	2.5 - 20 - 999.5	
Actuator stroke time (modulating controller at controller 1 only)	15 - 60 - 3000 s	
Hysteresis (of limit controller)	0 - 200 - 9999 (configurable decimal places)	
Minimum ON time	0.5 - 999.5	
Maximum pulse frequency	0 - 60 1/min.	
Output level limit	0 - 100%	
Pull-in delay	0.00 - 999.5 s	
Drop-out delay	0.00 - 999.5 s	
Limit controller monitoring	Off On	
Alarm tolerance	0 - end of range	
Alarm delay	0 - 9999 s	
Response during Hold	0% 100 Frozen Hold value	
Hold value	0 - 100%	
Response on error	0% 100% Frozen Hold value	
Min. setpoint limit	0 - 9999 (configurable decimal places)	
Max. setpoint limit	0 - 9999 (configurable decimal places)	
Controller special functions		
Manual mode	Manual mode not allowed Pulsed Switched	
Separate controllers	OFF ON	
I-component switch-off	Yes No	

12 Appendix

Parameter	Selection / value range factory setting	New setting
Switching output 1		
Function	No function Controller output 1 Controller output 2 Controller alarm 1 Controller alarm 2 <input type="checkbox"/> AF1 main variable <input type="checkbox"/> AF2 main variable <input type="checkbox"/> AF7 main variable <input type="checkbox"/> AF8 main variable <input type="checkbox"/> AF1 temperature <input type="checkbox"/> AF2 temperature <input type="checkbox"/> AF7 temperature <input type="checkbox"/> AF8 temperature Range or sensor error Calibration timer expired Wash timer	
Switching point	0 - 9999	
Interval to switching point Window width at AF1 / AF2	0 - 50% of range or 0 - 150°C	
Hysteresis	0 - 100% of range or -50 to +250	
Switch-on delay	00:00:00 - 01:00:00 H:M:S	
Switch-off delay	00:00:00 - 01:00:00 H:M:S	
Pulse time ¹	00:00:00 - 01:00:00 H:M:S	
During calibration	Inactive Active Status maintained	
On error	Inactive Active Status maintained	
In Hold mode	Inactive Active Status maintained	
Manual mode	No simulation Inactive Active	

¹ Drop-out delay is automatically deactivated when pulse times are greater than 0 seconds.

12 Appendix

Parameter	Selection / value range factory setting	New setting
Switching output 2		
Function	No function Controller output 1 Controller output 2 Controller alarm 1 Controller alarm 2 <input type="checkbox"/> AF1 main variable <input type="checkbox"/> AF2 main variable <input type="checkbox"/> AF7 main variable <input type="checkbox"/> AF8 main variable <input type="checkbox"/> AF1 temperature <input type="checkbox"/> AF2 temperature <input type="checkbox"/> AF7 temperature <input type="checkbox"/> AF8 temperature Range or sensor error Calibration timer expired Wash timer	
Switching point	0 - 9999	
Interval to switching point Window width at AF1 / AF2	0 - 50% of range or 0 - 150°C	
Hysteresis	0 - 100% of range or -50 to +250°C	
Switch-on delay	00:00:00 - 01:00:00 H:M:S	
Switch-off delay	00:00:00 - 01:00:00 H:M:S	
Pulse time ¹	00:00:00 - 01:00:00 H:M:S	
During calibration	Inactive Active Status maintained	
On error	Inactive Active Status maintained	
In Hold mode	Inactive Active Status maintained	
Manual mode	No simulation Inactive Active	

¹ Drop-out delay is automatically deactivated when pulse times are greater than 0 seconds.

12 Appendix

Parameter	Selection / value range factory setting	New setting
Analog output 1		
Signal selector	Actual value of main variable / Temperature Continuous controller output 1 Continuous controller output 2	
Signal type	0 - 10 V 0 - 20 mA 4 - 20 mA 10 - 0 V 20 - 0 mA 20 - 4 mA	
Scaling start of main variable	Dependent on measurement variable and measuring range	
Scaling end of main variable	Dependent on measurement variable and measuring range	
Response during calibration	Moving Frozen Safe value	
Response on error	Low (0 V / 0 mA / 3.4 mA) High (10.7 V / 22 mA) Frozen Safe value	
Response in Hold mode	Low (0 V / 0 mA / 3.4 mA) High (10.7 V / 22 mA) Frozen Safe value Moving	
Safe value	0 - 10.7 V 0 - 22 mA	
Simulation	Off On	
Simulation value	0 - 10.7 V 0 - 22 mA	
Analog output 2		
Signal selector	Actual value of main variable / Temperature Continuous controller output 1 Continuous controller output 2	
Signal type	0 - 10 V 0 - 20 mA 4 - 20 mA 10 - 0 V 20 - 0 mA 20 - 4 mA	
Scaling start of main variable	Dependent on measurement variable and measuring range	
Scaling end of main variable	Dependent on measurement variable and measuring range	
Response during calibration	Moving Frozen Safe value	

12 Appendix

Parameter	Selection / value range factory setting	New setting
Response on error	Low (0 V / 0 mA / 3.4 mA) High (10.7 V / 22 mA) Frozen Safe value	
Response in Hold mode	Low (0 V / 0 mA / 3.4 mA) High (10.7 V / 22 mA) Frozen Safe value Moving	
Safe value	0 - 10.7 V 0 - 22 mA	
Simulation	Off On	
Simulation value	0 - 10.7 V 0 - 22 mA	
Display		
Language	German English French Customized	
Lighting	When operated Off	
LCD inverse	Off On	
Measurement display type	Normal Trend Bar graph	
Lower display	Temperature Output level 1 Output level 2 Setpoint 1 Setpoint 2 None Compensated Uncompensated	
Upper display	Compensated Uncompensated Temperature Output level 1 Output level 2 Setpoint 1 Setpoint 2 None	
Max. / min. reset	No Yes	
Operator timeout	0... 1 - 10 min	
Contrast	0... 5 ...20	
Wash timer		
Cycle duration	0 - 240 hours (0 = off)	
Wash duration	1 - 60 - 1800 seconds	

12 Appendix

TEMP. COMPENSATION

LINEAR

TEMP. COEF CURVE (non-linear)

NAT. WATER (permissible temperature range 0 - 36°C as per EN 27 888)

FUNCTION

NO FUNCTION

 Alarm window AF1 MAIN VAR.

 Alarm window AF2 MAIN VAR.

 Limit function AF7 MAIN VAR.

 Limit function AF8 MAIN VAR.

 Alarm window AF1 TEMP.

 Alarm window AF2 TEMP.

 Limit function AF7 TEMP.

 Limit function AF8 TEMP.

SENSOR ERROR

CALIB. TIMER

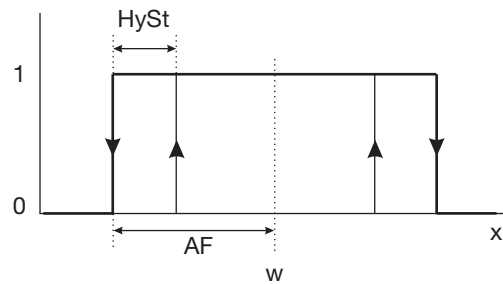

Alarm window AF1

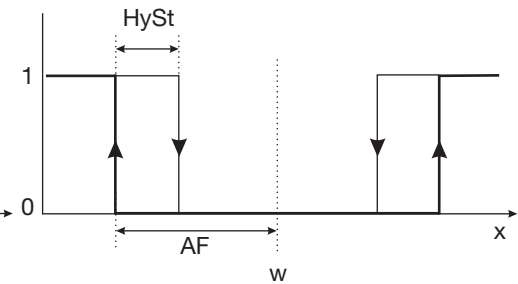

Alarm window AF2

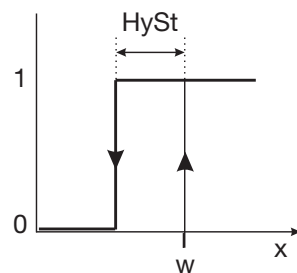

Limit function AF7

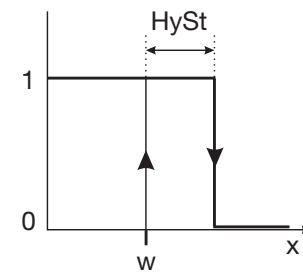

Limit function AF8

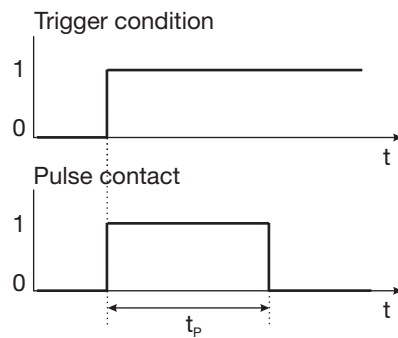

Pulse contact
Triggering condition longer than
pulse duration

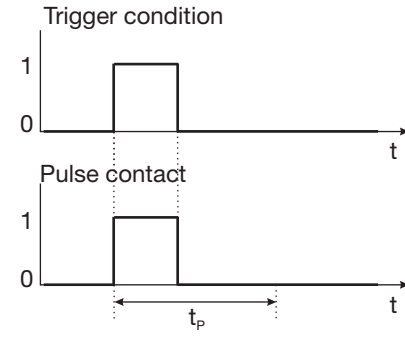

Pulse contact
Triggering condition shorter than
pulse duration

0	Off	t	Time
1	On	t_p	Pulse duration
AL	Spacing	w	Setpoint / Limit
HySt	Hysteresis	x	Actual value / Measurement value

MEAS. DISPLAY TYPE

NORMAL
 TREND
 BAR GRAPH

NORMAL

The measurement value, measurement variable and temperature of the medium are shown in normal display.

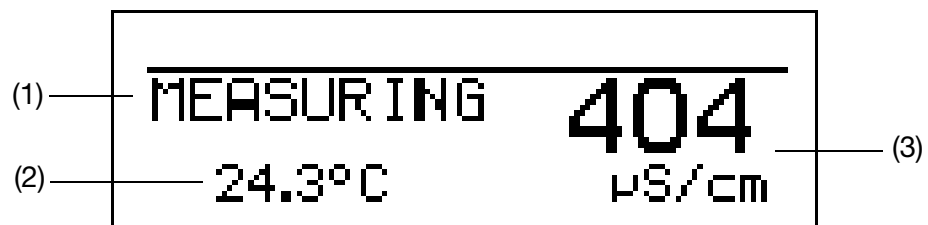

- (1) Operating mode
- (2) Lower display (temperature input)
- (3) Upper display (analog input measurement value)

12 Appendix

TREND

The operator can quickly see the direction in which the measurement is changing.

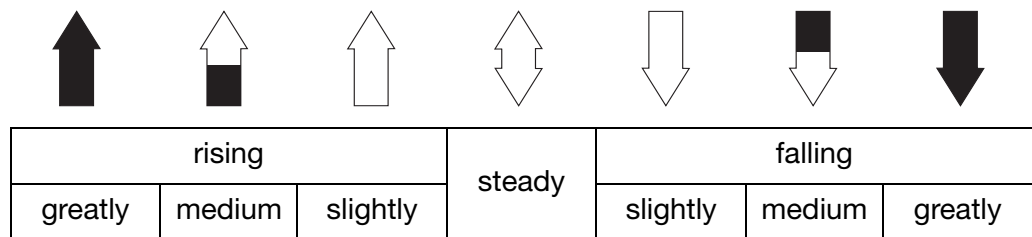
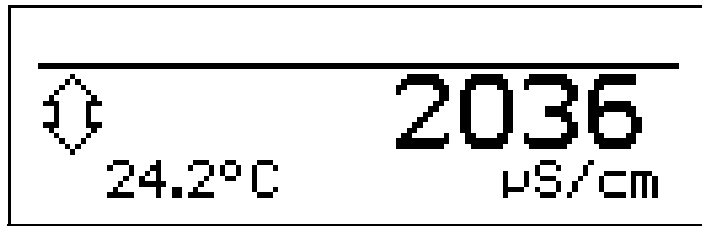

The measurement value trend is calculated over the last 10 measurement values. So with a sampling interval of 500 ms, the last 5 seconds are considered.

BAR GRAPH

- The analog input measurement value (main input variable) is displayed as a variable bar.
- The temperature is no longer displayed.
- Setpoints are marked with arrows above the bar graph for devices with configured control contact(s).

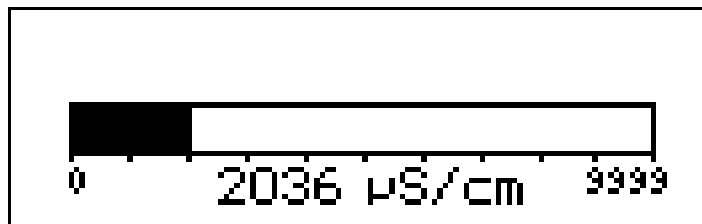

Scaling the bar

- * Activate "BAR GRAPH" as the measurement display type.
- * Use to select "BARGR. SCALE START".
- * Confirm the selection with .
- * Use or to enter the lower limit of the range to be displayed.
- * Confirm the selection with .
- * Use to select "BARGR. SCALE END".
- * Use or to enter the upper limit of the range to be displayed.

* Confirm the selection with .



To return to measuring mode:
press the  key repeatedly or wait for a "timeout".

LOWER DISPLAY

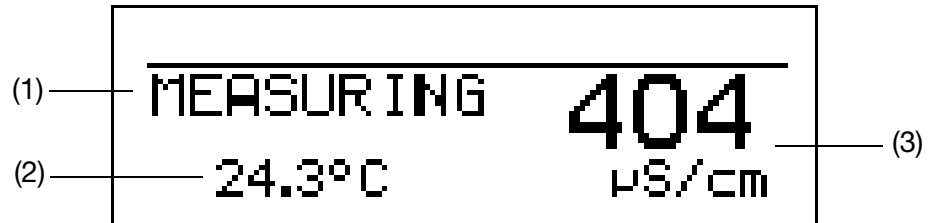

- (1) Operating mode
- (2) Lower display
- (3) Upper display

The following values can be assigned to the "lower" display (2):
This parameter is only available for the "NORMAL" and "TREND"
measurement display types.

TEMPERATURE
OUTPUT LEVEL 1
OUTPUT LEVEL 2
SETPOINT 1
SETPOINT 2
NONE
COMPENSATED
UNCOMPENSATED

UPPER DISPLAY

The following values can be assigned to the "upper" display (3):

COMPENSATED
UNCOMPENSATED
TEMPERATURE
OUTPUT LEVEL 1
OUTPUT LEVEL 2
SETPOINT 1
SETPOINT 2
NONE

12 Appendix

12.2 Glossary

Pulse width controller (output active with $x > w$ and P control structure)

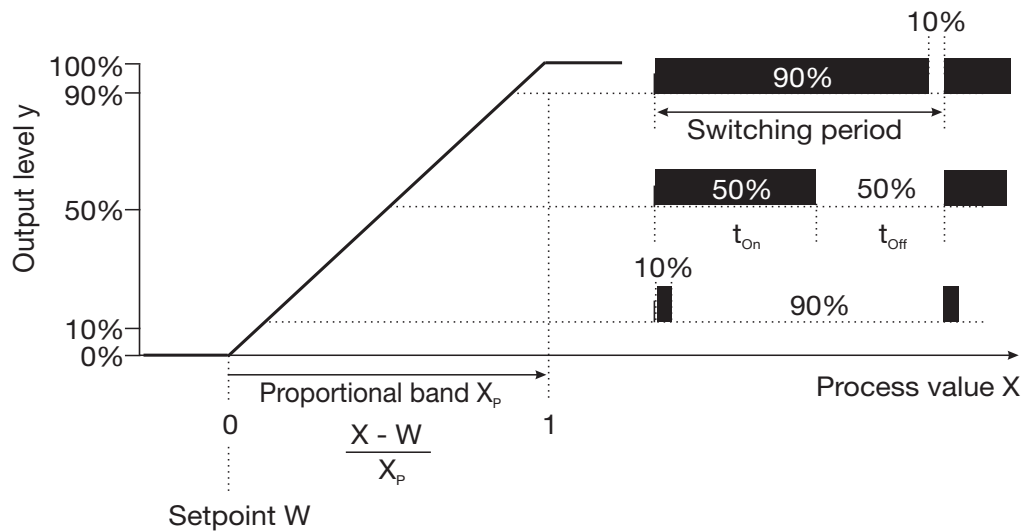

If actual value x exceeds setpoint W , the P controller will control in proportion to the control deviation. When the proportional band is exceeded, the controller operates with an output level of 100% (100% clock ratio).

Pulse frequency controller (output active with $x > w$ and P control structure)

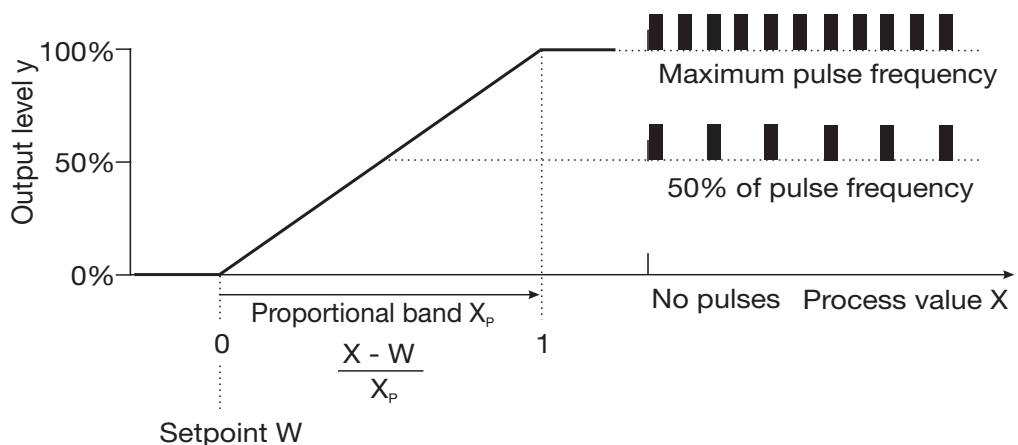

If actual value x exceeds setpoint W , the P controller will control in proportion to the control deviation. When the proportional band is exceeded, the controller operates with an output level of 100% (maximum switching frequency).

Calibration timer

The calibration timer indicates (on request) a required routine calibration. The calibration timer is activated by entering the number of days that must expire before there is a scheduled re-calibration (specified by the system or the operator).

Concentration measurement

The device can calculate the concentration of different mediums from the current measurement values of uncompensated conductivity and temperature.

Choice of concentration calculations:

NaOH (caustic soda)

- Range 1: 0 - 12 % by weight (0 - 90°C)
- Range 2: 20 - 50 % by weight (10 - 90°C)

HNO₃ (nitric acid)

- Range 1: 0 - 25 % by weight (0 - 50°C)
- Range 2: 36 - 82 % by weight (0 - 50°C)

H₂SO₄ (sulphuric acid)

- Range 1: 0 - 28 % by weight (0 - 100°C)
- Range 2: 36-85 % by weight (0 - 100°C)
- Range 3: 92 - 99 % by weight (0 - 100°C)

HCl (hydrochloric acid)

- Range 1: 0 - 12 % by weight (10 - 50°C)
- Range 2: 22 - 44 % by weight (0 - 50°C)

Customized characteristic

In this mode, the device can model a monotonically increasing input variable to any output value.

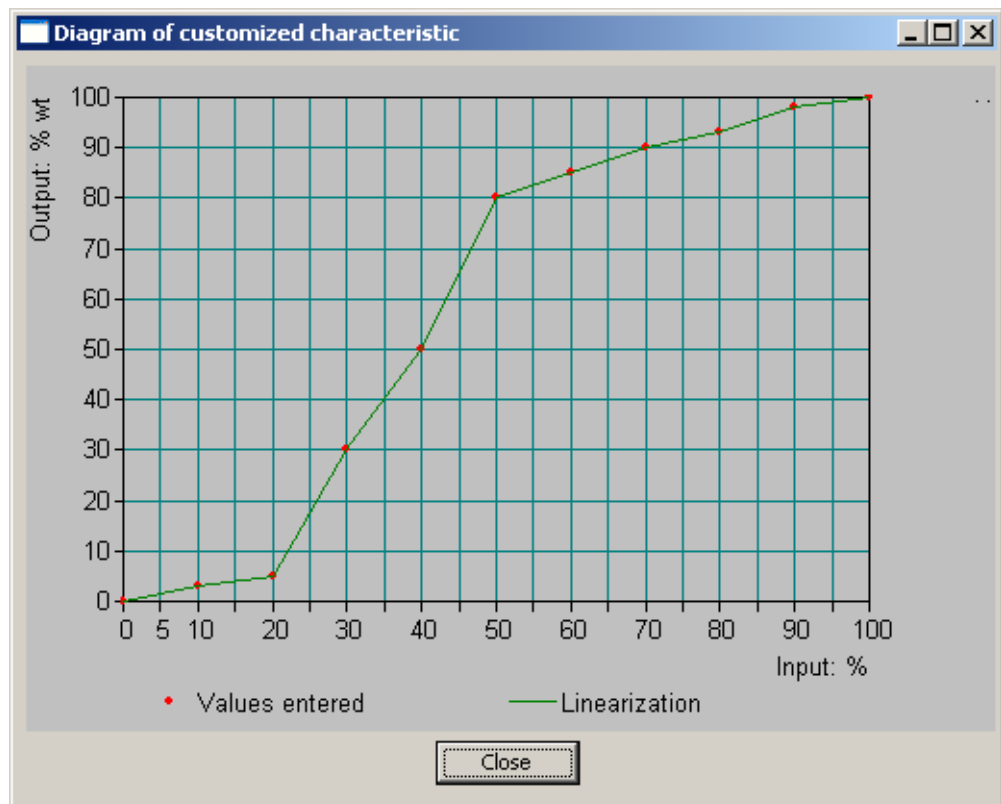

12 Appendix

The optional setup program is used to enter the requisite value table.

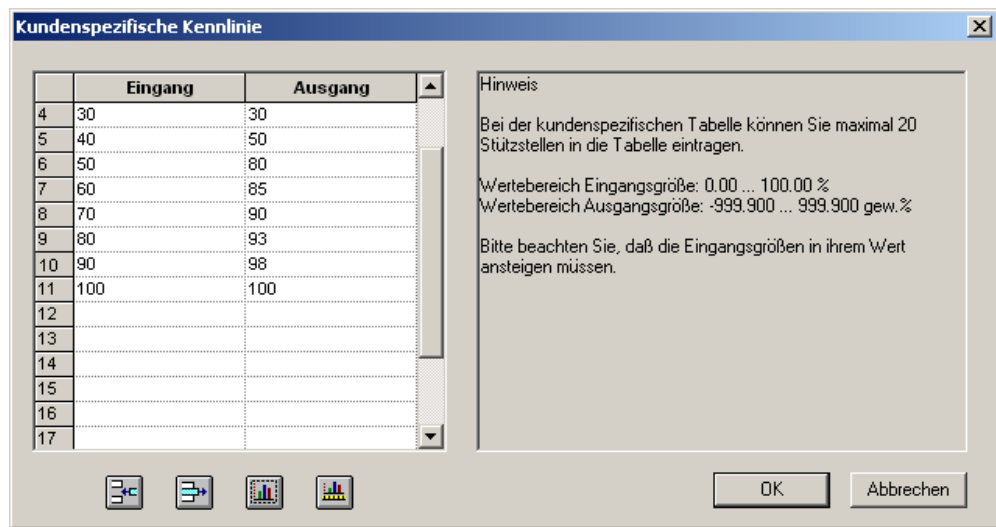

Customized table

In this mode, the input value can be displayed in accordance with a table (max. 20 value pairs). With this function, non-linear input variables can be displayed and linearized. Values can only be entered in the table using the optional setup program.

Max./min. value memory

This memory records the minimum and maximum input quantities that occur. This information can be used, for example, to assess whether the design of the connected sensor is suitable for the values that actually occur.

The max./min. value memory can be reset: Operator level / Display / Max./min. value memory / Yes,

See "Operator level parameters" page 65ff.

Conductivity temperature compensation

The conductivity of a measurement solution is temperature-dependent (the conductivity of a solution rises as the temperature increases). The dependency of conductivity and temperature describes the **temperature coefficient** of the measurement solution. As conductivity is not always measured for the reference temperature, automatic temperature compensation is integrated in this device. The transmitter uses the temperature coefficient to calculate the conductivity that would exist for a reference temperature from the current conductivity and the current temperature. This is then displayed. This process is called temperature compensation. Modern transmitters offer different ways to perform this temperature compensation.

- Linear compensation (constant temperature coefficient).
This type of compensation can be applied to many kinds of normal water, with acceptable accuracy. The temperature coefficient used is then approx. 2.2%/°C
- See below for non-linear compensation.
- Natural water (EN27888 or ISO 7888).
In this case, so-called non-linear temperature compensation is used. According to the standard cited above, the relevant type of compensation can be applied to natural groundwater, spring water and surface water. The definition range for the water temperature looks like this
 $0^{\circ}\text{C} \leq T < 36^{\circ}\text{C}$.

Determining the temp. coef. curve

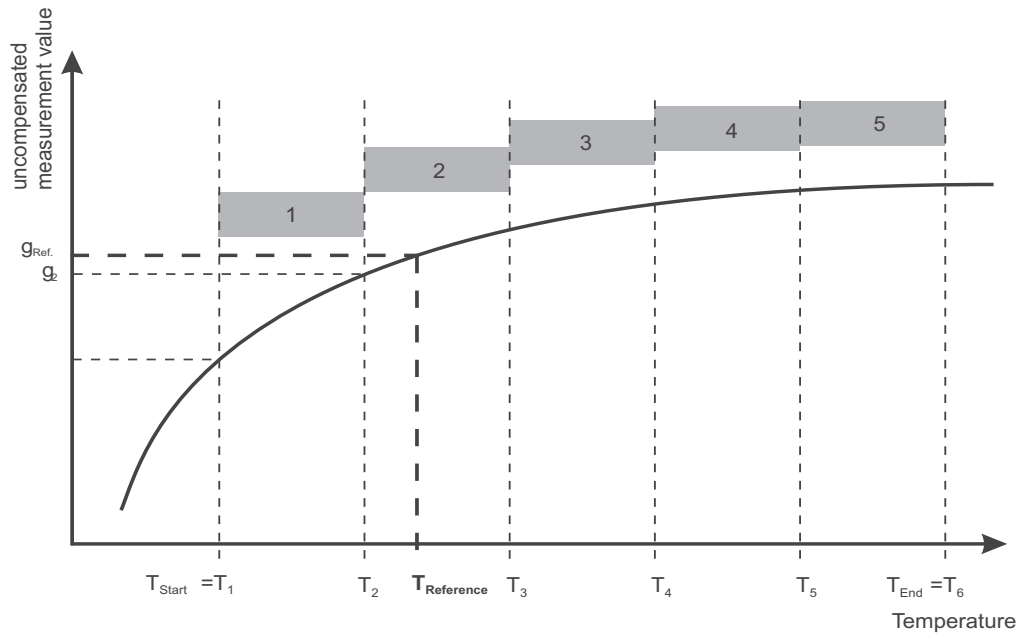

Calculating a temperature coefficient

$$\alpha_1 = \frac{\left(\frac{\gamma_1}{\gamma_{Reference}} - 1 \right) \times 100}{T_1 - T_{Reference}}$$

α = temperature coefficient (TC)

γ = uncompensated measurement value

Temp. coef. curve

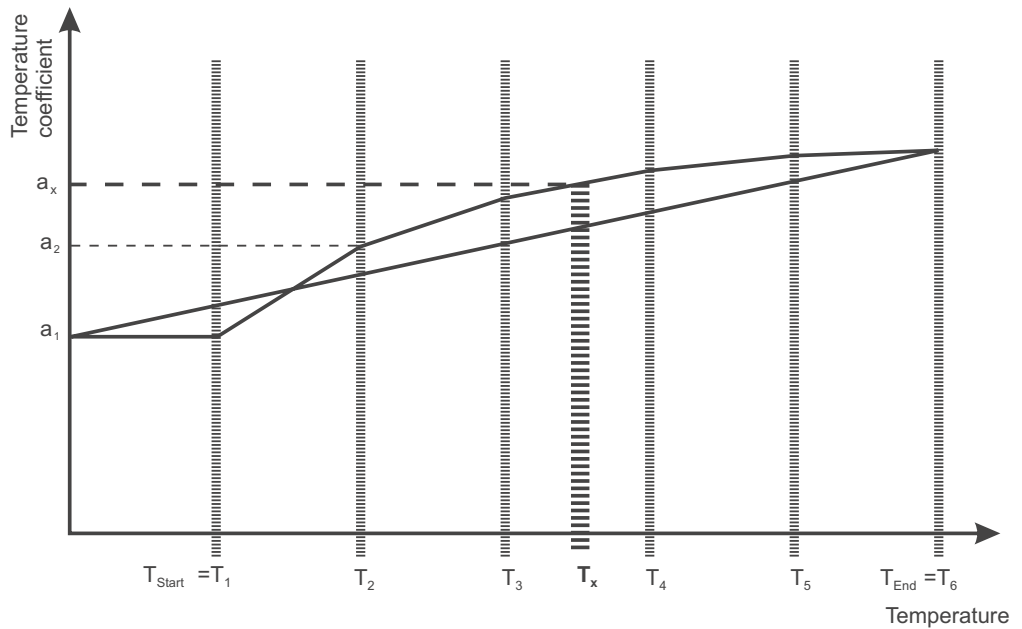

12 Appendix

Temperature compensation with the temp. coef. curve

The relevant temperature coefficient is determined from the temp. coef. curve by means of the current temperature of the medium.

Intermediate values, such as (α_x at T_x) between the two ascertained values (α_3 at T_3) and (α_4 at T_4) are linearly approximated.

As with linear temperature compensation, the compensated measurement value is calculated with the ascertained TC.



If the measured temperature is lower than the temperature at the beginning, the first TC is used for compensation.

If the measured temperature is higher than the temperature at the end, the last TC is used for compensation.

$$\gamma_{(\text{komp})} = \frac{\gamma_{(\text{mess})}}{\left(1 + \frac{\alpha_x}{100} * (T_x - T_{\text{Ref.}})\right)}$$

Sequence of automatic calibration

The temp. coef. curve is automatically applied in a temperature range specified by the user. The temperature range from beginning to end is divided into 5 segments of equal size.

The temperature range must be greater than 20 Kelvin and must overlap the reference temperature.

Example: Reference temperature 25°C, temperature at beginning 18°C and temperature at end 50°C.

Controller special functions:

The following functions can be activated in this menu

- Manual mode (activate controller outputs manually), **See section 6.7 "MANUAL mode / simulation mode", page 30**
- Separate controllers (see below)
- I-component switch-off (see below)

Separate controllers

This function is normally deactivated (factory setting or "No" selection).

In the deactivated state, the software stops the two controller outputs being able to work "against each other". So, for example, it is not possible to dose acid and lye at the same time.

If the controllers are separate ("yes" selection), each controller can be freely configured.

I-component switch-off

This function is normally deactivated (factory setting or "No" selection).

In the deactivated state, the controller works in accordance with general controller theory.

When I-component switch-off is activated ("yes" selection), the part of the output level that can be traced back to the I-component is set to zero when the setpoint is reached.

This can be beneficial with mutual neutralization (acid and lye dosing both possible) in one medication tank.

Wash timer

Automated sensor cleaning can be implemented with the wash timer. This function is assigned to a switching output (1 or 2) for this purpose.

The cycle duration (cleaning interval) can be set in the range from 1 to 240 hours. The wash duration (cleaning duration) is adjustable from 1 to 1800 seconds. For the duration of the wash, the controller is in the HOLD state, which lasts a further 10 seconds after the wash duration is over. A sensor calibration within the cycle duration restarts the wash timer.

The wash timer is deactivated with cycle duration "0".

12 Appendix

12.3 Template for panel cutout

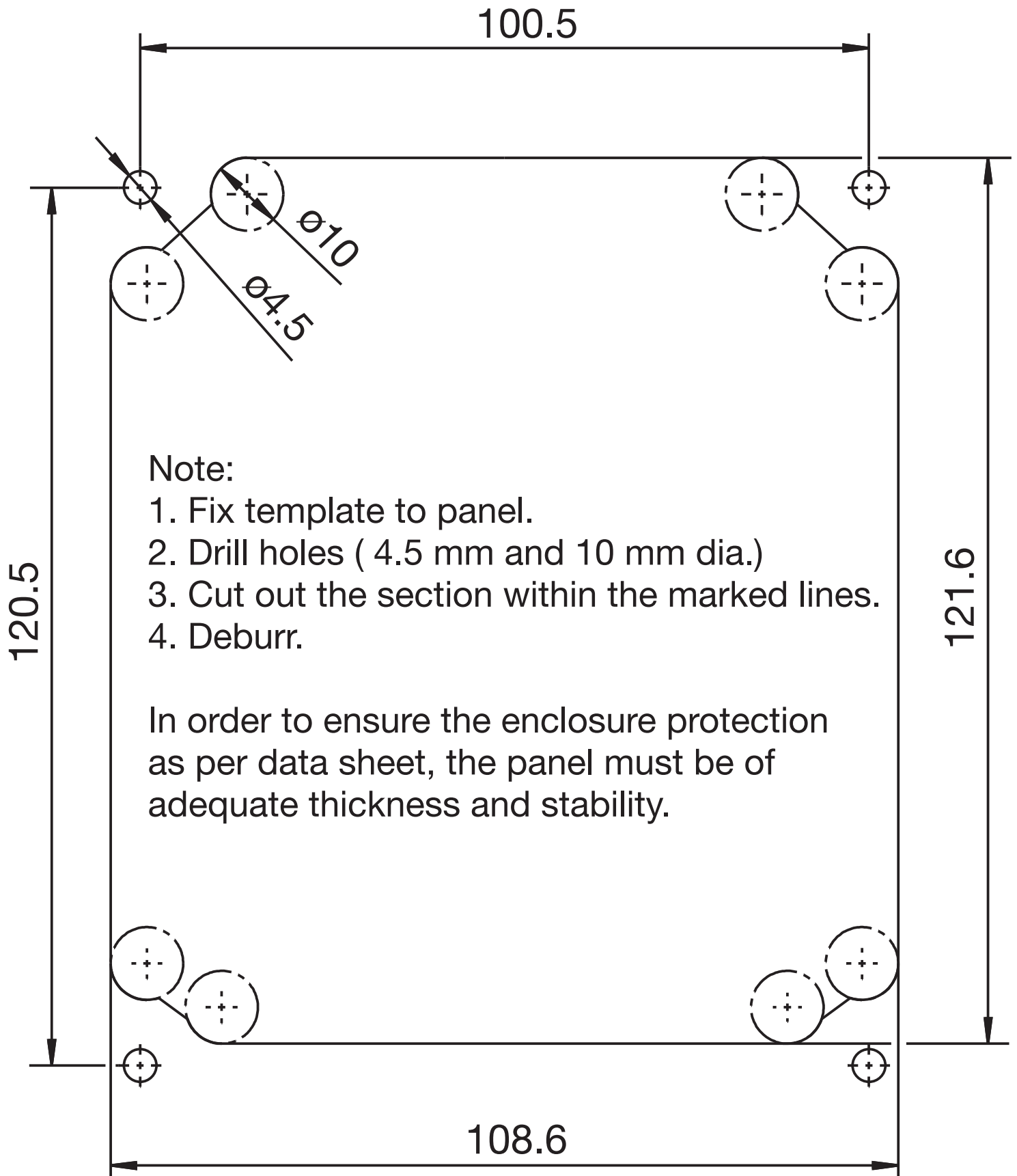

A

Accessories 10
Administrator 35
Analog output 38

B

Binary input 37, 58
Block diagram 8

C

Cable routing 19
Calibrating a conductive conductivity cell 48
 Non-linear temp. coefficient 54
 Relative cell constant 49
 Temp. coef. curve 54
 Temperature coefficient 51
Calibration enable 40
Calibration timer 76
Cell constant 40, 43
Concentration measurement 77
Conductivity input 37
Conductor 16
Conductor cross-sections 16
Configurable parameters 58
Controller channel 37
Controller functions 41
Controller special function 80
Customized characteristic 58, 77
Customized table 78

D

Data transmission 58
Date of manufacture 9
Delete 40
Display 24, 38
 Bar graph 74
 Lower 75
 Normal 73
 Trend 74
 Upper 75

E

Electrical isolation 17
Enable 37

F

Fixing brackets 11

G

Getting started 42

H

HOLD mode 34

I

I-component switch-off 80
Inputs 21
Installation position 11
Instrument status 24

M

MANUAL mode 30
MANUAL mode for analog outputs 33
MANUAL mode for switching outputs 30
Max. / min. value memory 78
Measuring range 58
MIN/MAX values 28
Mounting location 11

N

Nameplate 9

O

Operator 35
Operator level parameters 65
Order details 9
Output 29
Output level display 29
Outputs 21
Overrange 58–59
Overview of MANUAL mode 31

P

Panel mounting 13
Parameter 37
Parameter explanations 65
Parameter overview 26
Parameter table 65
Password 35, 60
Pin assignment 21
Pipe 12
Pipe installation 12
Principle 25
Pulse frequency controller 76
Pulse width controller 76

Note:

This index is not intended to be exhaustive! Please read the operating instructions before starting up the device!

13 Index

R

Reference symbols 5

S

Setting examples 43

Setup program 58

Simulating the switching outputs 32

Simulation mode 30

Special controller function 38

Special controller functions 38

Special functions 58

Sunlight 11

Surface 11

Surface mounting 11

Switching output 38, 58

T

Temp. coef. curve 79

Temperature compensation

 Conductivity 78

Temperature input 37

W

Warning symbols 5

Wash timer 71, 81

Washing contact 71, 81

Weather protection roof 12



JUMO GmbH & Co. KG

Street address:
Moritz-Juchheim-Straße 1
36039 Fulda, Germany
Delivery address:
Mackenrodtstraße 14
36039 Fulda, Germany
Postal address:
36035 Fulda, Germany
Phone: +49 661 6003-0
Fax: +49 661 6003-607
Email: mail@jumo.net
Internet: www.jumo.net

JUMO Instrument Co. Ltd.

JUMO House
Temple Bank, Riverway
Harlow - Essex CM20 2DY, UK
Phone: +44 1279 63 55 33
Fax: +44 1279 63 52 62
Email: sales@jumo.co.uk
Internet: www.jumo.co.uk

JUMO Process Control, Inc.

6733 Myers Road
East Syracuse, NY 13057, USA
Phone: 315-437-5866
1-800-554-5866
Fax: 315-437-5860
Email: info.us@jumo.net
Internet: www.jumousa.com