

CTRC Series

Flexible Rogowski Current Transformer - Installation Guide

1 CTRC Models

Models in **bold** are stock items.

Model	Rated Amps	Coil Inside Diameter	Coil Length
CTRC-03100-0250	250 A	3.1 in (8.0 cm)	9.7 in (24.6 cm)
CTRC-03100-0400	400 A		
CTRC-03100-0600	600 A		
CTRC-03100-1000	1000 A		
CTRC-04500-1000	1000 A	4.5 in (11.4 cm)	15.75 in (40.0 cm)
CTRC-04500-1600	1600 A		
CTRC-04500-2000	2000 A		
CTRC-07500-1000	1000 A	7.5 in (19.0 cm)	23.6 in (60.0 cm)
CTRC-07500-1600	1600 A		
CTRC-07500-2000	2000 A		
CTRC-07500-3000	3000 A		
CTRC-07500-3200	3200 A		
CTRC-07500-4000	4000 A		
CTRC-12000-2000	2000 A	12.0 in (30.5 cm)	39.4 in (100 cm)
CTRC-12000-3000	3000 A		
CTRC-12000-3200	3200 A		
CTRC-12000-4000	4000 A		
CTRC-12000-5000	5000 A		
CTRC-12000-6000	6000 A		

Figure 1: CTRC Model Table



Danger: Hazardous Voltages
Potential shock hazard from dangerous high voltage exists.

2 Overview

The CTRC series flexible Rogowski coil current transformer (RCCT) can monitor AC line current in circuits up to 600 Vac and nominal currents up to 6000 Amps. They can be opened and are flexible for ease of installation around bus bars and multiple conductors.

They are intended for field installation within distribution and control equipment such as panelboards, switchboards and industrial control equipment to measure the current on branch circuits and feeders.

The CTRC Series CTs may be used with electric energy meters, like the WattNode® meters, or for other current measuring purposes.

RCCTs are different in a few key ways from standard CTs. They do not contain a ferromagnetic core, so they cannot saturate, they have excellent linearity, and they have very low phase angle errors. Because they lack a core, it is possible to make them flexible and lightweight. Furthermore, the coil output signal is low voltage (less than one volt AC) and low current (microamps or less), so they are safer than ratio CTs. CTRC models require an integrating conditioning module, since the output of the coil represents the rate of current change (derivative) of the actual current. RCCTs are dependent on the uniformity of the windings in the sense coil, making them more sensitive to the position of the conductor(s) being measured in the opening and more sensitive to the magnetic fields from external conductors.

2.1 Precautions

- Only qualified personnel or **licensed electricians** should install current transformers (CTs). The line voltages of 120 Vac to 600 Vac can be lethal!
- These transformers are intended to be installed in accordance with ANSI/NFPA 70, “National Electrical Code” (NEC). Follow all local electrical codes.
- Do not install CTs in the area of breaker arc venting.
- Do not install CTs where they may be exposed to temperatures below -4°F or above 140°F (-20°C or above 60°C), excessive moisture, dust, salt spray, or other contamination.
- CTRC current transformers measure alternating current (AC) only. They do not measure direct current (DC).

2.2 Pre-Installation Checklist

- The current transformer’s full-scale rated current should normally be somewhat above the maximum current or breaker rating of the circuit being measured.
- It is preferable to install the CT and meter close to each other. However, you may extend the CT wires by 300 feet (100 m) or more by using twisted-pair cable (optionally shielded) and by running the output wires away from high current and line voltage conductors.

2.3 Components

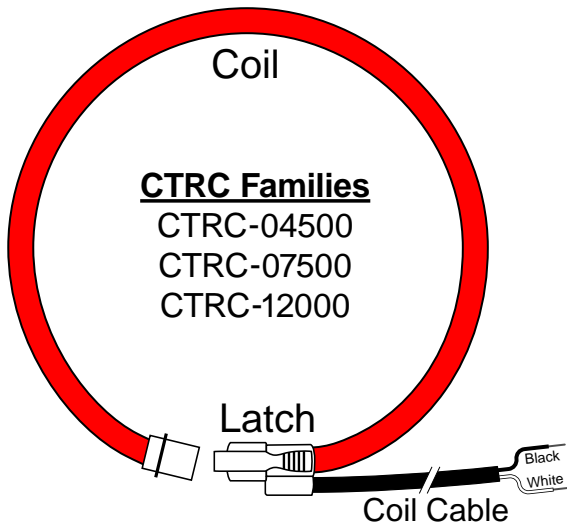

Figure 2: Large CTRC Coils

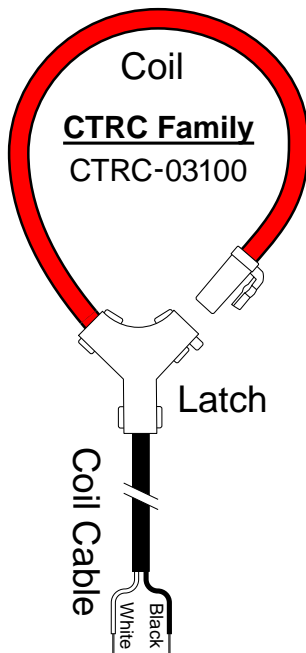

Figure 3: Small CTRC Coil

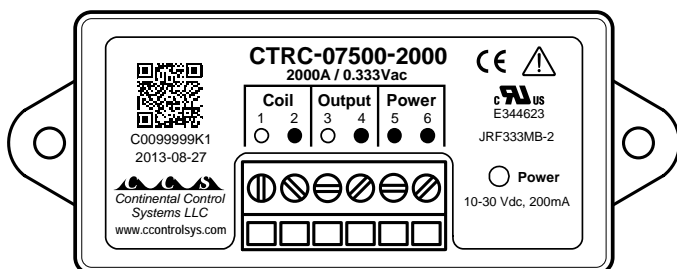

Figure 4: Conditioning Module

The CTRC series Rogowski coil current transformers include the following components:

Coil: the Rogowski coil senses the current. It is a flexible red coil with a plastic latch piece to hold the ends together and connect to the coil cable.

Latch: this is the black plastic piece that holds the ends of the coil together.

Coil cable: the coil cable is the black shielded cable that runs from the coil to the conditioning module.

Conditioning module: this is the small white plastic box with the six-position green screw terminal. It processes the raw output of the Rogowski coil into a 333 mVac signal that is compatible with WattNode meters.

Output wires: (not shown) these are the white and black twisted wires that connect the conditioning module to the meter.

Power supply: (not shown) a power supply is required to operate the conditioning module. The power supplies offered by Continental Control Systems (see section 7.7) can power at least twelve conditioning modules.

When you order a CTRC model, it includes the following:

- One coil with attached coil cable (59 in, 1.5 m)
- One conditioning module
- One output wire set (8 ft, 2.4 m)
- One set of color-coded wire labels

The power supply is not included and must be ordered separately, generally one supply for every three to twelve CTRCs.

3 Connecting the Current Transformers

WARNING: To reduce the risk of electric shock, always open or disconnect the circuit from the power distribution system (or service) of the building before installing or servicing current transformers.

- 1) The CTRC includes a conditioning module (small white rectangular box). It must be mounted or located away (at least 2 in or 5 cm) from line conductors to provide safety and to ensure best accuracy. If possible, use the mounting tabs to mount the conditioning module to an enclosure panel or wall. Because of the short length of the coil cable (59 in, 1.5m), be sure to position the conditioning module near the coil location.
- 2) The coil comes wired to the conditioning module. If necessary, it may be disconnected for ease of installation. If you do disconnect the coil, **take care to reconnect the matching coils and conditioning modules.** The serial numbers are printed on both so that they can be matched up (the serial number is the ten character alphanumeric string starting with "C").

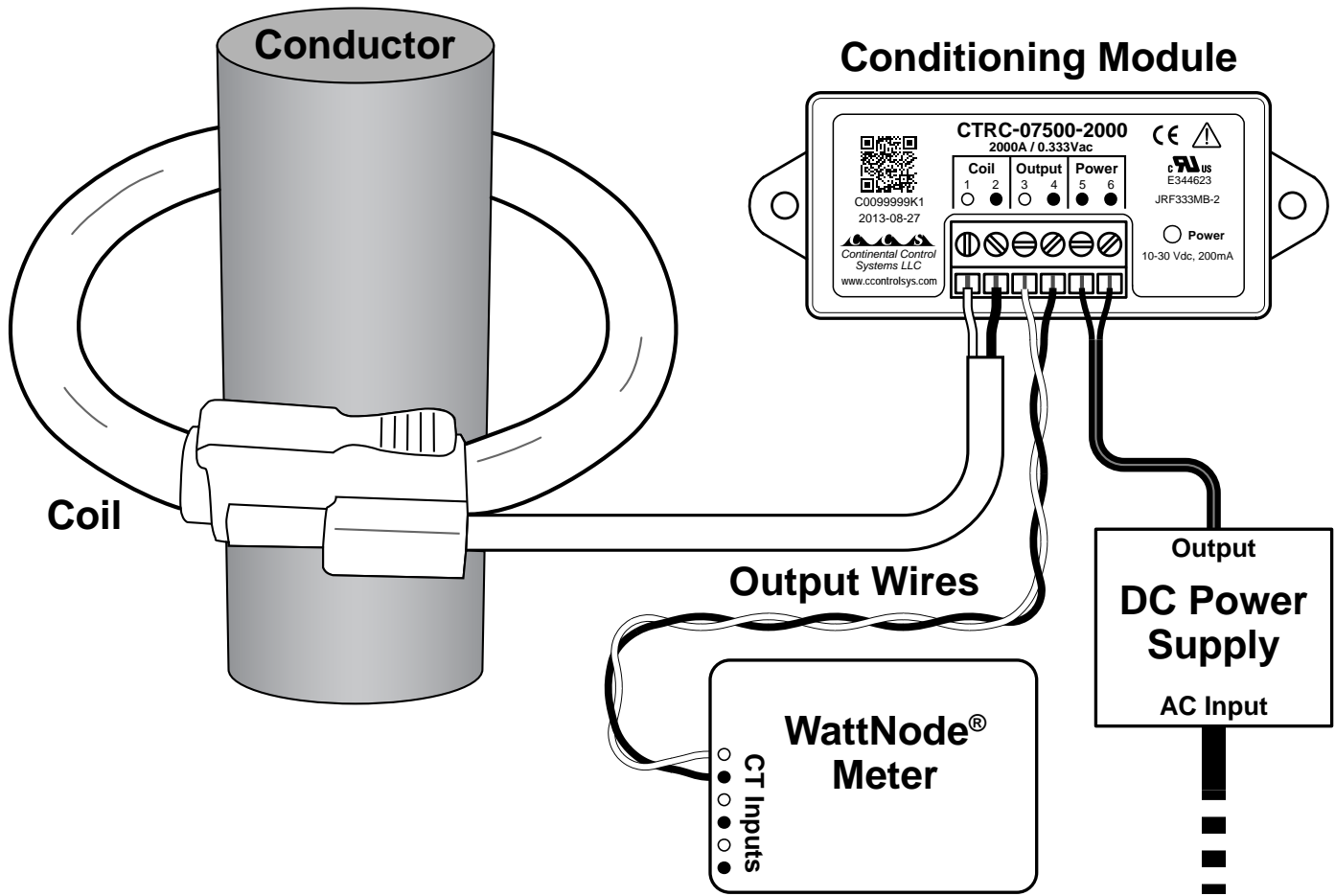

Figure 5: Overview Connection Diagram

- 3) To open the larger CTRC-04500, CTRC-07500, and CTRC-12000 coils, squeeze (pinch) the ribbed sections as shown below, while gently pulling the removable coil end free.



Figure 6: Open Large CTRC Coils

To open the small CTRC-03100 coil, you may squeeze the release flaps either a location “A” or “B” and pull the coil away from the latch as shown in **Figure 7**. It is harder to squeeze the flaps at location “B”, but sometimes more effective.

Avoid pulling on the red, flexible part of the coil, since it is easy to damage.

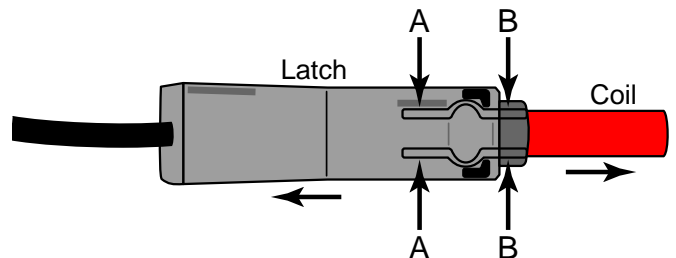

Figure 7: Open Small CTRC Coil

- 4) Place the CT coil around the conductor or group of conductors.

For best accuracy position the latch (where the ends of the coil join):

- Away from any other line conductors
- Away from the conductors being measured if there is slack in the coil

- 5) Be sure to point the SOURCE arrow or **Label toward source** facing the source of current: generally the utility meter or the circuit breaker for branch circuits. Note: If the CT is mounted backwards, the measured power will be negative.

- 6) Close the CT by inserting the removable end into the latch. Press until it snaps together. Squeezing the catches may make it easier to close.
- 7) *Optional:* Secure the CT coil to the conductor with a cable tie.
- 8) If you disconnected the coil cable from the conditioning module, reconnect it to the terminal block positions **1** (white wire) and **2** (black wire) under **Coil**, taking care to match coils and conditioning modules correctly (they are calibrated as a set) using the serial numbers.
- 9) The white / black output wires (from the conditioning module to the meter) are supplied connected to the conditioning module, but if they were disconnected or replacement wires are being used, wire them to the terminal block positions **3** (white wire) and **4** (black wire) under **Output**.
- 10) Route the output wires from the conditioning module to the meter or measurement device. **Be sure to route the output wires so that they do not directly contact live terminals or bus bars.**
- 11) Connect the white and black output wires to the color-coded terminals on the meter or monitoring device.

4 Connect the Power Supply

For best accuracy, either use a supply with an earth grounded output (like the FWA020012A-10B) or tie the output to earth ground (as shown in the directions for the MDR-10-12).

4.1 General

The CTRC conditioning module power input is not polarity sensitive, so the positive power supply wire may be connected to either terminal.

If you need to power multiple CTRC conditioning modules, you may daisy chain the power to additional conditioning modules. Either supply (FWA020012A-10B or MDR-10-12) can power at least 12 CTRC conditioning modules. We recommend 18 AWG to 16 AWG stranded wire for the power supply connections.

If you are not using a supply provided by CCS, you should be able to adapt the directions below or contact CCS technical support for assistance.

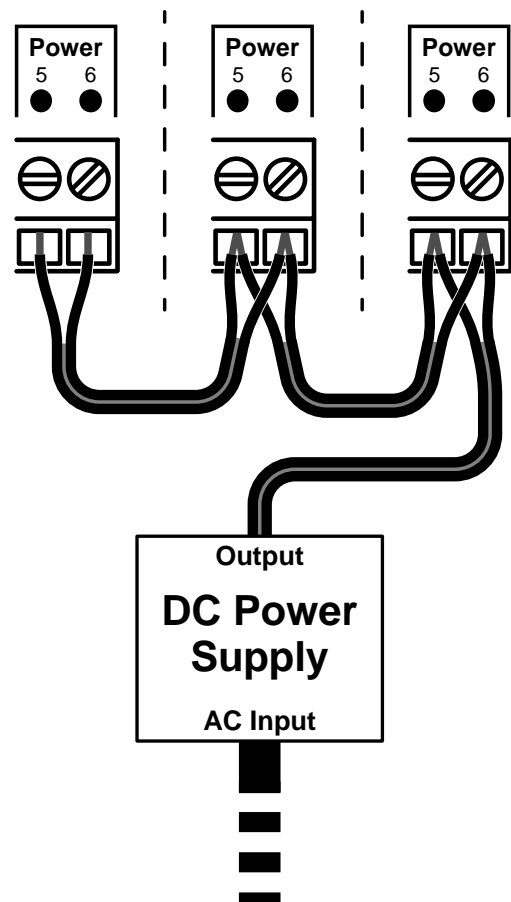

Figure 8: Daisy Chain Power

The supply and supply wires must not come in contact with hazardous voltages on live terminals or busses.

4.2 FWA020012A-10B Power Supply

This supply comes with a US standard NEMA 5-15P three-prong cordset 6 feet (1.8 m), and permanently attached output cord 6 feet (1.8 m) with tinned leads.

- The power supply output wires are connected to the **Power** terminals on the conditioning module (positions **5** and **6**). The polarity does not matter.

4.3 MDR-10-12 Power Supply

The MDR-10-12 supply may be DIN rail mounted. It provides screw terminal connections for both the line Vac input connections: ground ⊕, neutral **N**, and line **L**; and for the output connections: **+V**, **-V**, and **DC OK** (not used).

- When wiring more than one wire to a screw terminal on the MDR-10-12, you may twist the two wires together and put them both in the screw terminal (if they fit) or use a wire nut and run a single wire into the screw terminal.
- Start by running a short (approximately 5 inch) jumper wire from the ground ⊕ terminal (or any other ground point) to the negative output **-V** terminal. This is necessary because leaving the output floating introduces noise, degrading the CTRC accuracy.

- Connect ground \ominus , neutral **N**, and line **L** to a 100 - 240 Vac branch circuit with overcurrent protection (fuse or circuit breaker). Use 18 AWG to 14 AWG wire.
- Connect wires from the **+V** and **-V** outputs to the **Power** terminals on the conditioning module (positions **5** and **6**). The polarity does not matter.

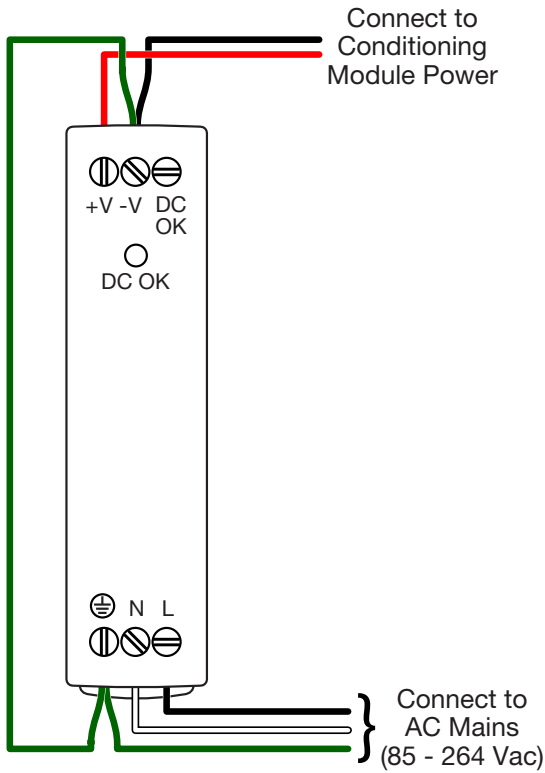

Figure 9: DIN Rail Power Supply Wiring

5 Installation Notes

- If the white and black output wires are reversed, the measured power will be negative.
- When connecting to a WattNode meter, align the white CTRC lead wire with the white dot on the label, and the black lead wire with the black dot on the label.
- Be careful to match the CT to the voltage phases being measured. Make sure the $\varnothing A$ CT measures the current on the $\varnothing A$ conductor, and the same for phases B and C. Use colored labels or tape to identify the wires.
- You may double loop the CTRC around a conductor: this halves the opening diameter and halves the effective rated amps. For example, double looping a CTRC -12000-4000 results in a CT with an opening diameter of 6 inches (15 cm) and a rated current of 2000 amps.

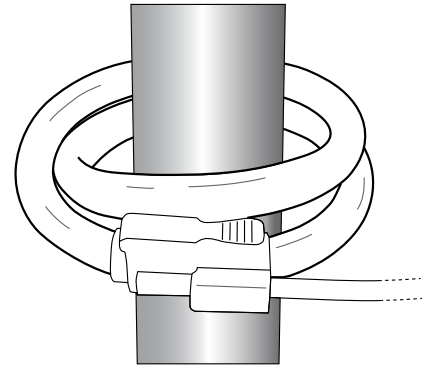

Figure 10: Double Looped Coil

5.1 Accuracy Notes

There are several factors that may affect the accuracy of CTRC current transformers.

- For highest accuracy, center the conductor(s) being monitored in the coil, have the conductor(s) largely fill the coil, or position the conductor(s) away from the latch. Also position the latch away from other conductors. For details, see section **7.3 Accuracy**.

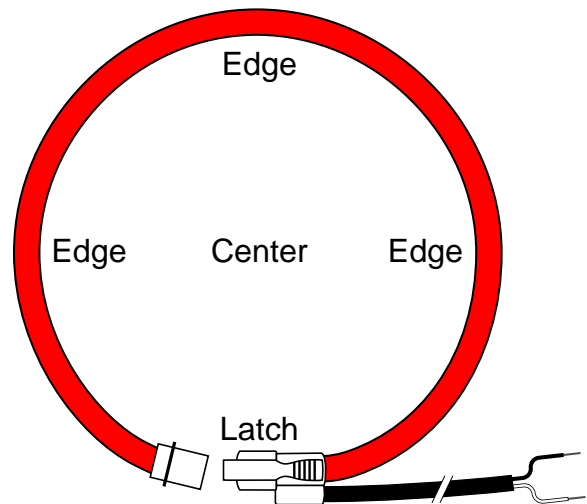

Figure 11: CTRC Position Accuracy

- The CTRC coils do not interfere with each other and may be installed in contact with other coils.
- Avoid locating the coil near corners or sharp bends in the conductor being monitored.
- Current flowing through nearby external conductors can degrade the accuracy (both gain and phase). To prevent degraded accuracy, keep the CTRC latch away from external conductors, choose a CTRC coil size that is not excessively large, and keep the coil positioned away from external conductors as much as possible.
- VFD (variable frequency drive) noise may degrade the CTRC accuracy, especially at low currents. To minimize this, try to locate the CTRC coil and conditioning module as far as possible from the VFD unit. Never put the CTRC coil around the wires connecting the output of VFD to the motor.

- The readings may vary up to $\pm 1.5\%$ over the full temperature range -4°F to 140°F (-20°C to 60°C). Near room temperature, the variation is much smaller. The phase angle is not affected by temperature.
- Extending the output wire length slightly attenuates the signals (approximately 0.2% with 200 foot or 60 m output wires). Longer output wires are also more susceptible to electromagnetic interference, so we recommend shielded twisted-pair cables for long runs (ground the shield at one end).
- We recommend against extending the shielded coil cable, as the raw coil signal is very low amplitude and is more susceptible to interference.

6 References

For more information about current transformers, see: http://www.ccontrols.com/w/Current_Transformer_Articles

For more information about connecting current transformers to WattNode meters, see the appropriate WattNode meter manual.

7 Specifications

Type: Flexible Rogowski coil current transformer with conditioning module

7.1 Models

See Figure 1: CTRC Model Table.

7.2 Electrical

Output wires: 8 feet (2.4 m), 22 AWG, white / black twisted

Optional: up to 100 feet (30 m)

Frequency: 50/60 Hz nominal (safe to operate at any frequency)

Maximum voltage: 600 Vac

Maximum safe amperage: $>10,000\text{A}$. Unlike conventional CTs, Rogowski coil CTs have negligible secondary current (typically less than one microamp) and very low secondary voltages (typically less than 100 mVac), so even during extreme overcurrent, the secondary voltage, current, and power dissipation will all be very low.

Measurement category: CAT III, 600 Vac

UL recognized: file number E344623 (PICQ2), UL standard 61010B-1

7.3 Accuracy

All measurements at 77°F (25°C) and 60 Hz unless otherwise noted.

Accuracy: $\pm 1.0\%$ of reading from 5% to 120% of rated primary current

Conductor position sensitivity (see Figure 11 diagram):

Family	Center	Edge	Latch
CTRC-03100	No added error	$\pm 1.5\%$	$\pm 5.0\%$
CTRC-04500	No added error	$\pm 1.0\%$	$\pm 4.0\%$
CTRC-07500	No added error	$\pm 1.0\%$	$\pm 4.0\%$
CTRC-12000	No added error	$\pm 1.0\%$	$\pm 3.0\%$

Figure 12: Conductor Position Sensitivity Table

External conductor sensitivity: $\pm 2.0\%$ of full-scale maximum. To clarify: if an external conductor carrying this CT's rated current is touching this CT, especially near the latch, then the output of this CT may change by up to $\pm 2.0\%$ of the rated current.

External conductor sensitivity (CTRC-03100 models only): $\pm 2.5\%$ of full-scale maximum

Positioned in corner: $\pm 1.0\%$ maximum (if the CT is placed at a sharp corner of the conductor being measured)

Positioned in corner (CTRC-03100 models only): $\pm 2.0\%$ maximum

Varying temperature: $\pm 1.5\%$ from -4°F to 140°F (-20°C to 60°C)

Phase Angle

Phase angle: ± 0.50 degrees (30 minutes) from 5% to 120% of rated current

Conductor position sensitivity: ± 0.10 degrees max

External conductor sensitivity: ± 0.25 degrees max

Positioned in corner: ± 0.10 degrees maximum

Varying temperature: -4°F to 140°F (-20°C to 60°C): ± 0.10 degrees

7.4 Conditioning Module

Output at rated amps: 333.33 mVac (one-third volt)

Maximum output: 1.3 Vac

Power requirements: 10 – 30 Vdc (12 Vdc or 24 Vdc recommended), 50 mA typical, 70 mA maximum

7.5 Environmental

Operating temperature: -4°F to 140°F (-20°C to 60°C)

Operating humidity: Non-condensing, 5 to 90% relative humidity (RH)

Pollution: POLLUTION DEGREE 2

Indoor use: Suitable for indoor use.

Outdoor use: Suitable for outdoor use when mounted in a NEMA 3R or 4 (IP 66) rated enclosure.

7.6 Mechanical

Dimensions:

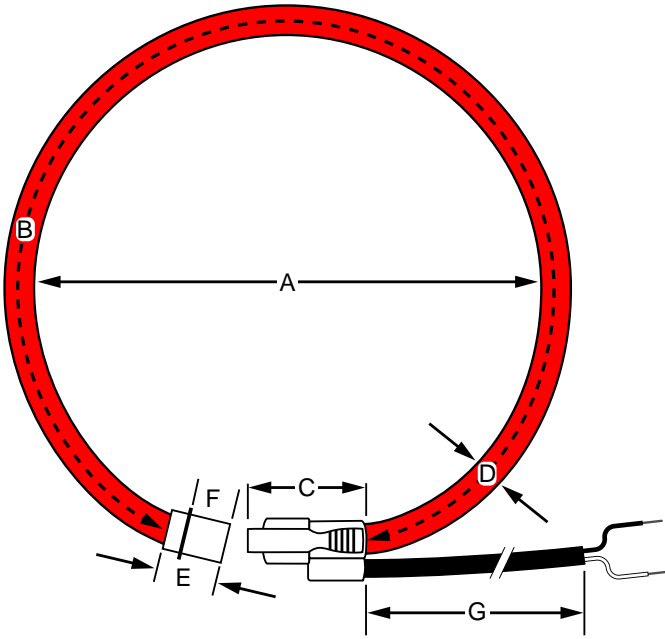

Figure 13: Large CTRC Dimensional Drawing

Dimension	CTRC Family		
	CTRC-04500	CTRC-07500	CTRC-12000
A	4.5" (11.4 cm)	7.5" (19.0 cm)	12.0" (30.5 cm)
B	14.9" (37.8 cm)	22.7" (57.8 cm)	37.8" (96.0 cm)
C	1.8" (4.57 cm)		
D	0.47" (12 mm) diameter		
E	0.9" (22.5 mm)		
F	0.59" (15 mm)		
G	59" (150 cm)		

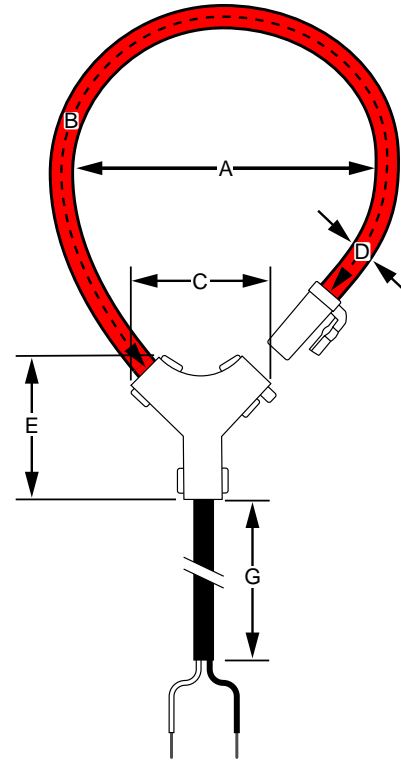

Figure 14: Small CTRC Dimensional Drawing

Dimension	CTRC-03100 Family
A	3.15" (8.0 cm)
B	11" (28.0 cm)
C	1.62" (4.1 cm)
D	0.30" (7.5 mm) diameter
E	1.69" (4.3 cm)
G	59" (150 cm)

Weight:

Conditioning module: 2.2 oz (61 grams)

Coils with coil cable

CTRC-03100: 3.6 oz (102 grams)

CTRC-04500: 5.5 oz (155 grams)

CTRC-07500: 6.8 oz (192 grams)

CTRC-12000: 9.4 oz (265 grams)

Output wires: 1.5 oz (42 grams)

7.7 CTRC Power Supplies

The CTRC current transformers may be purchased with the following power supplies:

~~FWA020012A-10B --Discontinued--~~

Make and model: Elpac (ICCNexergy) FWA020012A-10B with tinned leads

Type: Desktop power supply

Input cord: 6 ft (1.82 m) cord with US standard three-prong connector (NEMA 5-15) and IEC 320 connector.

AC input voltage: 85 – 264 Vac, 100 – 240 Vac nominal

Input frequency: 47 – 63 Hz

Operating temperature: 32°F to 140°F (0°C to 60°C)
(full load at 104°F (40°C), 50% load at 140°F (60°C))

Input current: less than 0.5 A RMS

Output voltage: 12 Vdc

Output current: 1.67 amps (this is sufficient to power
24 CTRC conditioning modules)

Output power: 20 watts

Output cord: 6 ft (1.82 m), 18 AWG, tinned leads

Emissions: FCC class B, CISPR22 class B

Features: No minimum load, over-voltage protection,
over-temperature protection, over-current protection,
short circuit protection, earth grounded output

MDR-10-12

Make and model: Mean-Well Industrial MDR-10-12

Type: DIN-rail mount power supply (DIN rail TS-35/7.5
or 15)

AC input voltage: 85 – 264 Vac, 100 – 240 Vac nominal

Input frequency: 47 – 63 Hz

Operating temperature: -4°F to 158°F (-20°C to 70°C)
(full load at 140°F (60°C), 50% load at 158°F (70°C))

Input current: less than 0.5 A RMS typical

Output voltage: 12 Vdc

Output current: 0.84 amps (this is sufficient to power
12 CTRC conditioning modules)

Output power: 10 watts

Emissions: CISPR22 class B

Features: No minimum load, over-voltage protection,
overload protection

Alternate Supplies

Alternate supplies may also be used, subject to the following:

Output voltage: 10 – 30 Vdc (12 Vdc or 24 Vdc
recommended)

Output current: at least 70 mA per CTRC

Ground output: Use a supply with an earth grounded
output or connect a jumper wire from earth ground to
the output common (or return) lead. Failure to do this
will result in degraded accuracy, especially at lower
currents.

8 Warranty

All products sold by Continental Control Systems, LLC (CCS) are guaranteed against defects in material and workmanship for a period of five years from the original date of shipment. CCS's responsibility is limited to repair, replacement, or refund, any of which may be selected by CCS at its sole discretion. CCS reserves the right to substitute functionally equivalent new or serviceable used parts.

This warranty covers only defects arising under normal use and does not include malfunctions or failures resulting from: misuse, neglect, improper application, improper installation,

water damage, acts of nature, lightning, product modifications, alterations or repairs by anyone other than CCS.

Except as set forth herein, CCS makes no warranties, expressed or implied, and CCS disclaims and negates all other warranties, including without limitation, implied warranties of merchantability and fitness for a particular purpose.

8.1 Limitation of Liability

In no event shall CCS be liable for any indirect, special, incidental, punitive or consequential damages of any kind or nature arising out of the sale or use of its products whether such liability is asserted on the basis of contract, tort or otherwise, including without limitation, lost profits, even if CCS has been advised of the possibility of such damages.

Customer acknowledges that CCS's aggregate liability to Customer relating to or arising out of the sale or use of CCS's products, whether such liability is asserted on the basis of contract, tort or otherwise, shall not exceed the purchase price paid by Customer for the products in respect of which damages are claimed. Customer specifically acknowledges that CCS's price for the products is based upon the limitations of CCS's liability set forth herein.



<http://www.ccontrols.com>

3131 Indian Rd.
Boulder, CO 80301
(303) 444-7422

Document number: CTRC-Install-1.10d
Revision Date: May 13, 2019

©2014-2019 Continental Control Systems, LLC
WattNode® is a registered trademark of Continental Control Systems, LLC.