

## Hygro/hygrothermal transducers (hygrometric)

- for measuring relative humidity and temperature
- for mounting indoors, outdoors, and in air ducts
- with resistance, current or voltage outputs
- for permanent use in the high-humidity range up to 100 % RH (duct version)
- no power supply necessary for passive instruments
- sensing element does not need any maintenance in clean air (no regeneration necessary)

Humidity transducers in the 907031 series make use of the hygroscopic property of specially prepared plastic fibers to determine relative humidity in air. After this preparation, the integrated humidity sensing element is capable of absorbing moisture. The effect that can be measured externally is a change in length. A precision mechanism senses the humidity-dependent change in length, transmits this movement to the slider of a resistive track and produces it as a linearized resistance output at the terminals.

The standard output is 100 to 138.5  $\Omega$ , thus corresponding to a Pt100 signal. This enables the direct connection to standard measurement, control and recording instruments, for processing the measurement signal.

Other instrument versions with different resistance outputs, with normalized current or voltage output signals as well as humidity transducers with additional temperature acquisition complete the product spectrum.

The humidity transducers are suitable for both climatic applications and industrial humidity measurement. Of particular advantage is the fact that the sensing element is highly resistant to water, which permits continuous use in the high-humidity range, up to saturation level. Under normal atmospheric conditions, the sensing element requires practically no maintenance. Any dirt deposits resulting from dust-laden air can be washed off. The working range of the sensing element covers 30 to 100 % RH at permissible ambient temperatures from -40 to +80 °C. Instrument versions with a passive output offer the additional advantage of not needing a power supply of their own for operation.

General applications include climate monitoring, ventilation, humidifying and de-humidifying installations, storage of fruit and vegetables as well as ripening areas for food.



Duct version



Indoor version

## Technical data

### Humidity

<b>Sensing element:</b>	plastic, hygrometric sensing element is water-resistant and largely maintenance-free
<b>Measuring/working range:</b>	0/30 to 100 % RH
<b>Measuring accuracy:</b>	$\pm 2.5$ % RH                      above 40 % RH to tolerance characteristic   below 40 % RH TK = 0.1 % RH/°C (referred to 20 °C and 50 % RH)
<b>Medium:</b>	air, unpressurized, not corrosive
<b>Permissible air velocity:</b>	duct version: 8 m/sec max. (15 m/sec with wind shield) indoor version: 15 m/sec max.
<b>Response times:</b>	50 % time: 1.5 min at $v = 2$ m/sec stabilization time: 30 to 40 min at $v = 2$ m/sec
<b>Humidity output (passive):</b>	0 to 100 $\Omega$ linear, 2-wire circuit 0 to 200 $\Omega$ linear, 2-wire circuit 0 to 1000 $\Omega$ linear, 2-wire circuit 100 to 138.5 $\Omega$ linear, 2-wire circuit (Pt100 standard values, see Data Sheet 906000)
<b>Permissible loading:</b>	1.0 W
<b>Electric strength:</b>	42 V
<b>Insulation resistance:</b>	10 M $\Omega$
<b>Humidity output (active):</b>	0 to 20 mA, 4-wire circuit 4 to 20 mA, 2-wire circuit 0 to 10 V, 3-/4-wire circuit

## Technical data

### Temperature

<b>Sensing element:</b>	Pt100 temperature sensor to EN 60751
<b>Measuring range:</b>	duct version, passive: -40 to +80 °C (take note of permissible ambient temperature) duct version, active: -30 to +100 °C (take note of permissible ambient temperature) indoor version, passive: 0 to 60 °C
<b>Measuring accuracy:</b>	±0.5 °C
<b>Temperature output (passive):</b>	Pt100
<b>Measuring current:</b>	1 mA (recommended)
<b>or</b>	0 to 20 mA, 4-wire circuit
<b>current/voltage signal:</b>	4 to 20 mA, 2-wire circuit 0 to 10 V, 3-/4-wire circuit

### Electrical data for active versions with transmitter

<b>Supply voltage:</b>	15 to 30 V DC also 24 V AC ±10 % (for 0 to 10 V output)
<b>Burden:</b>	500 Ω max. for current output
<b>Load resistance:</b>	10 kΩ min. for voltage output
<b>Power consumption:</b>	5 mA per measuring range, 10 mA with AC version
<b>Linearity error:</b>	<0.5 % for temperature output
<b>Output signals:</b>	0 to 20 mA; 4 to 20 mA; 0 to 10 V
<b>Electromagnetic compatibility:</b>	EN 61326

### Construction

<b>Housing:</b>	duct version: ABS plastic fitted with stainless steel probe indoor version: ABS plastic
<b>Cable entry:</b>	duct version: via M20 × 1.5 gland indoor version: via flush-type box
<b>Terminals:</b>	for conductor cross-sections up to 0.5 mm <sup>2</sup>
<b>Protection:</b>	duct version: IP64 indoor version: IP20
<b>Ambient temperature:</b>	duct version: -20 to +60 °C on housing, -40 to +80 °C on probe indoor version: 0 to 60 °C
<b>Operating position:</b>	probe tube vertically downwards or horizontal, mounted directly through openings in housing or, optionally, by mounting flange. On indoor version unrestricted, the ventilation slots preferably at right angles to the air flow.
<b>Weight:</b>	duct version: approx. 400 g indoor version: approx. 200 g

## Maintenance notes

### Humidity sensor

The hygrometric sensor requires no maintenance in normally clean air. Corrosive media or those containing solvents may cause faulty readings or failure depending on the type and concentration. As is the case with nearly all humidity sensors, any deposits that may form a water-repellent film on the sensor are liable to cause damage, for instance, resin aerosols, paint aerosols or fumigating substances.

Avoid direct sunlight.

### Indoor version

Cleaning and adjustment of the sensor can only be carried out in the factory.

### Duct version

The special sensing element is water-resistant and can be cleaned in water. Do not use strong solvents. When using gentle detergents, rinse the sensing element thoroughly afterwards. Only rinse the plastic sensing element and the stainless steel sheath in water, not the housing head.

### Calibration

A special ageing process ensures long-term stability of the humidity sensing element. The regeneration known from hair sensor elements is not required.

The transducers are factory-calibrated at 23 °C room temperature and 50 % RH. The calibration can be checked (on the duct version only) using the sensor checks that are available as accessories. In addition, the sensor will indicate 100 % RH when the sensing element is wetted with water. Should recalibration become necessary, this can be done by carefully adjusting the setting screw at the tip of the sheath. Please note that a very slight movement of the adjusting screw when the sensing element is wet will produce a fairly large change in the calibration in the dry range.

### Drying

After cleaning, the humidity sensor must not be dried with warm or hot air, by using a hair drier, for example.

### Caution

Interference with internal parts will invalidate any warranty claim.

## Humidity tolerance characteristic

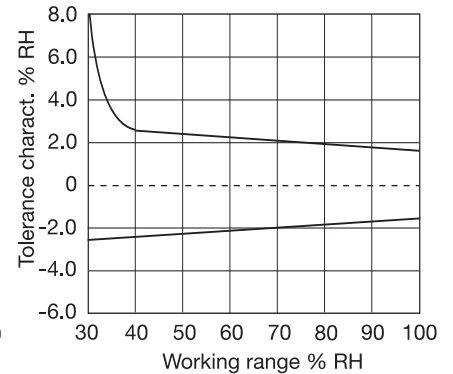
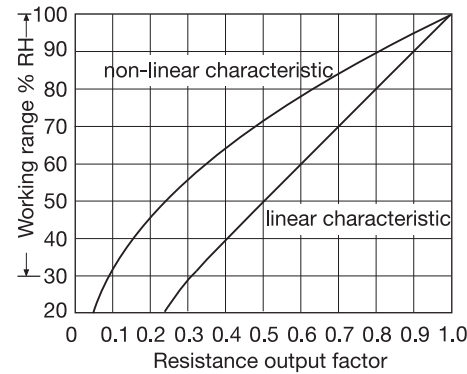

## Step response for Polyga

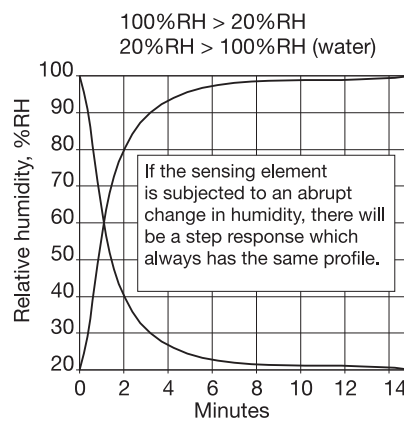

## Reaction of the Polyga sensing element

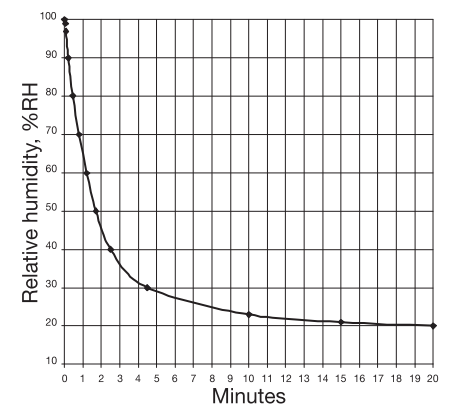

## Dimensions

### Indoor version

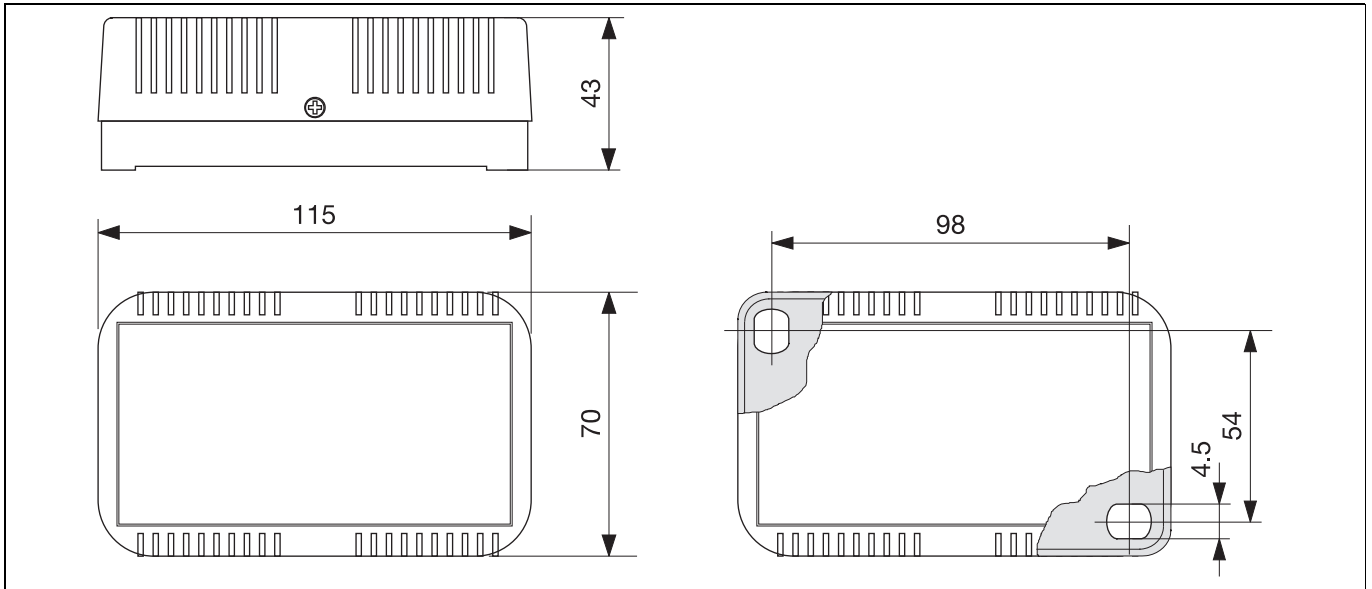

### Duct version

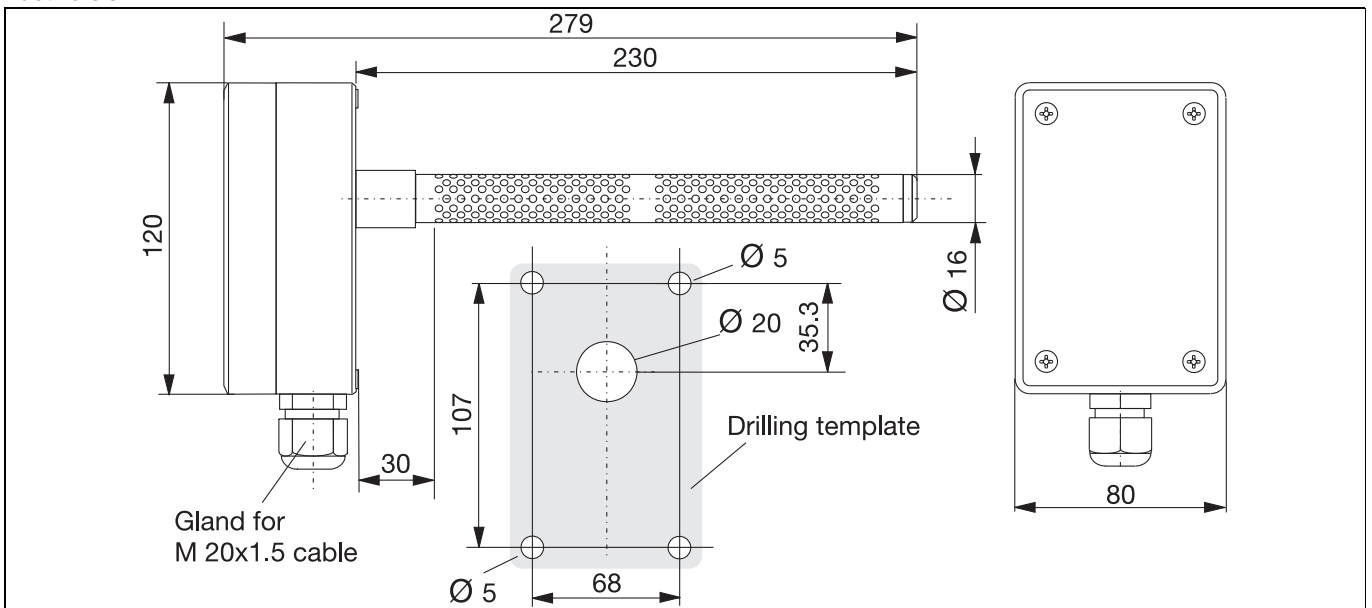

## Accessories

### Mounting bracket

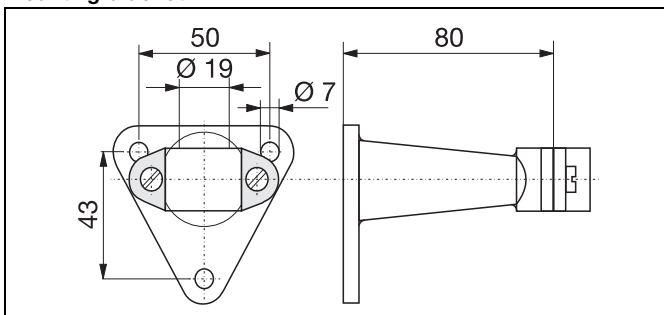

### Sheath for outdoor mounting (sun and rain protection)

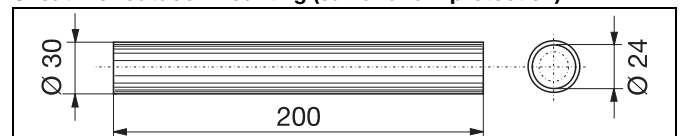

### Sheath for indoor and outdoor mounting (wind shield)

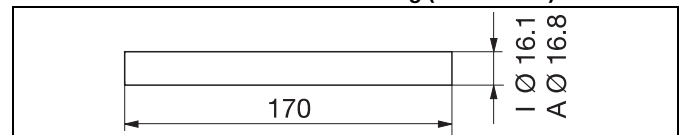

## Connection diagrams

### Connection diagram for passive transducers with resistance output

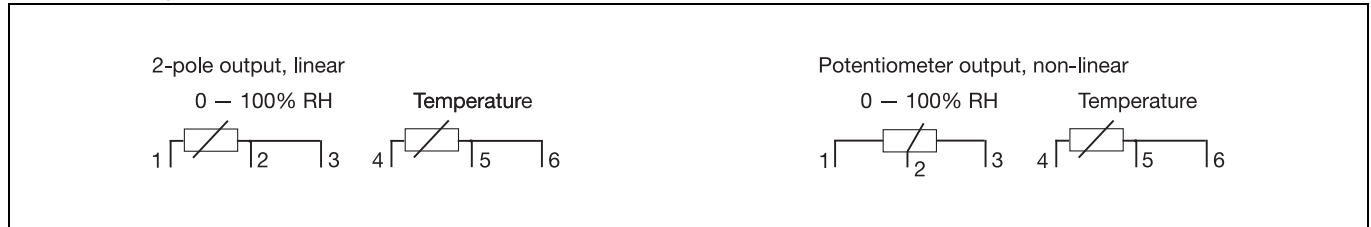

### Connection diagram for active transducers, supply voltage 15 to 30 V DC (24 V AC only with 0 to 10 V DC output)

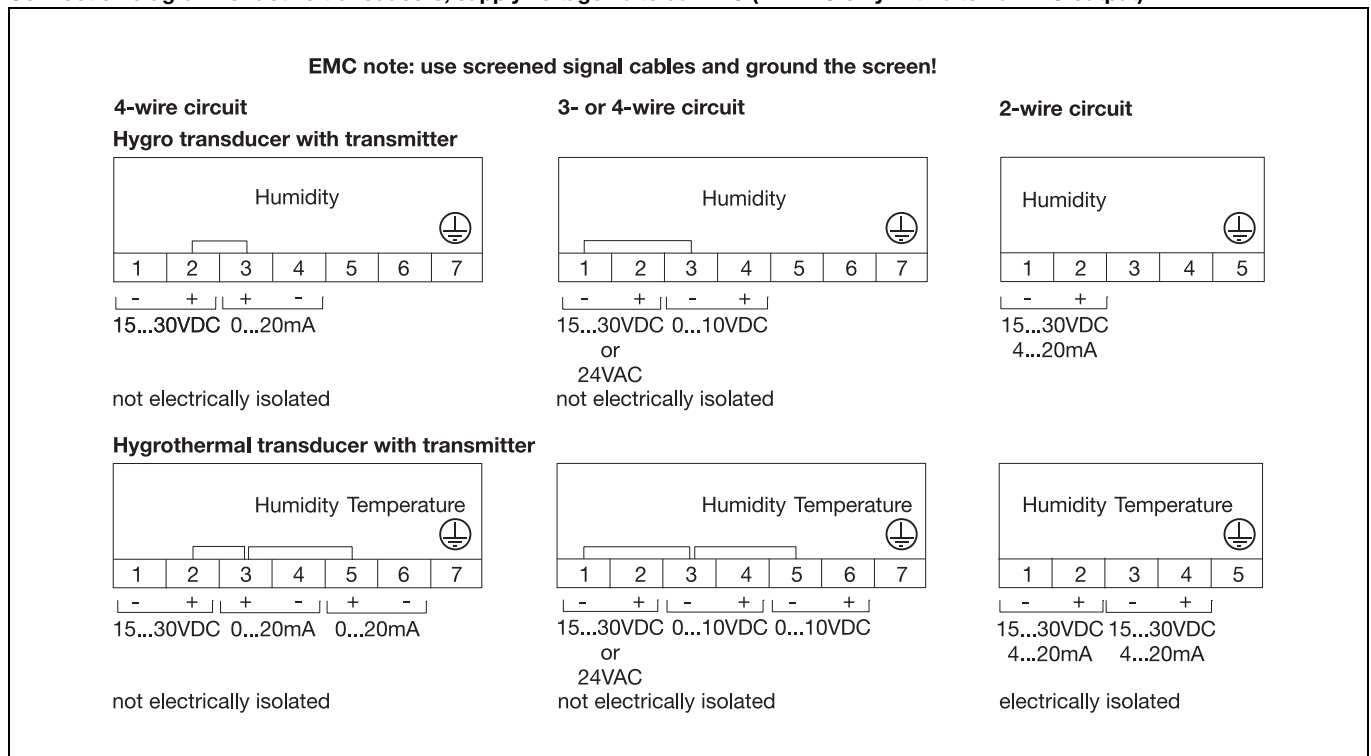

### Block diagram for 2-wire circuit 4 to 20 mA

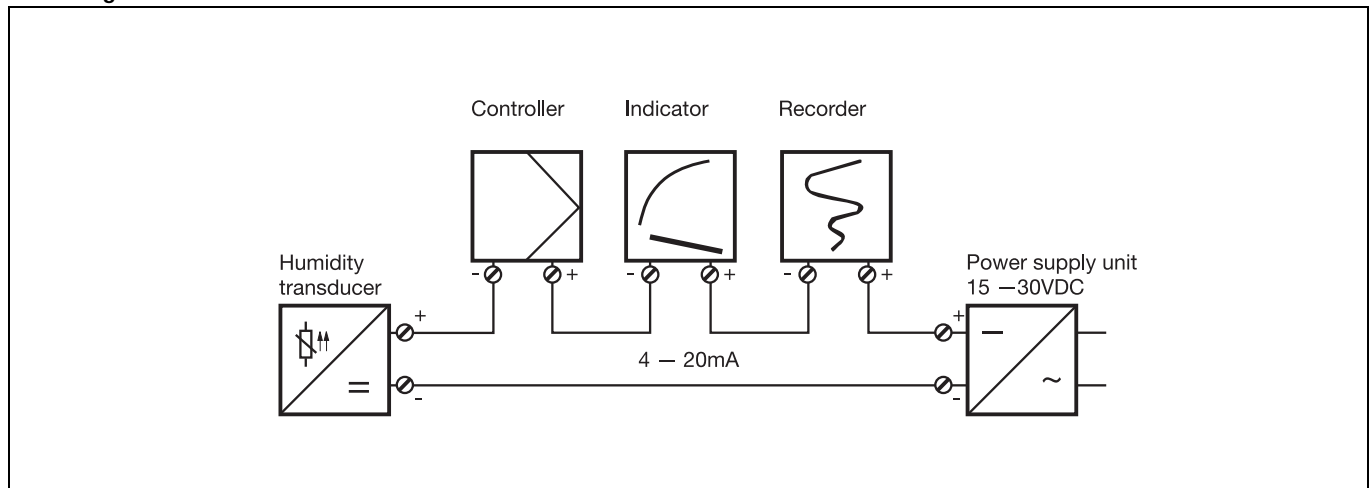

**Order details: Hygro/hygrothermal transducers (hygrometric)**

**(1) Basic type**

907031/10	Hygro/hygrothermal transducer, indoor version (passive)
907031/20	Hygro/hygrothermal transducer, duct version (passive)
907031/30	Hygro/hygrothermal transducer, duct version (active)

**(2) Hygro/hygrothermal transducers**

x x x	1	humidity (1-channel-output)
x	2	humidity and temperature
x x	3	humidity and temperature (temperature passive)

**(3) Ranges<sup>1</sup>**

x	21	0 to 100 % RH/-30 to +60 °C
x	15	0 to 100 % RH/-40 to +80 °C
x	32	0 to 100 % RH/0 to 60 °C
x	36	0 to 100 % RH/0 to 100 °C
x x x	99	special range (on request)

**(4) Output signals (humidity / temperature)<sup>2</sup>**

x x	016	0 to 100 Ω (2-pole output, linear)/Pt100 (passive)
x x	017	0 to 200 Ω (2-pole output, linear)/Pt100 (passive)
x x	019	0 to 1000 Ω (2-pole output, linear)/Pt100 (passive)
x x	021	100 to 138.5 Ω (2-pole output, linear)/Pt100 (passive)
x	005	4 to 20 mA/4 to 20 mA
x	011	0 to 20 mA/0 to 20 mA
x	065	0 to 10 V DC/0 to 10 V DC
x x x	999	special output (on request)

**(5) Extra codes**

x x x	000	no extra code
-------	-----	---------------

<b>Order code</b>	(1)	(2)	(3)	(4)	(5)
<b>Order example</b>	907031/10	- 1	- 32	- 021	/ 000

**Note**

Suitable power supply units for transmitters can be found in Data Sheet 707500.  
 Recommended power supply units: Type TN-22/02, 055 (1-channel) and TN-67/02, 055 (4-channel)

**Stock versions**

Order code	Part No.
907031/10-1-32-021/000	90/90590502
907031/10-3-32-021/000	90/90590507
907031/20-1-15-021/000	90/90590512
907031/20-3-15-021/000	90/90590517
907031/30-1-21-005/000	90/90590541
907031/30-2-21-005/000	90/90590544

1. Please note humidity working range and max. permissible ambient temperature (see Technical data).  
 2. With selection (2) type code 1 "humidity", the second output signal is not applicable with selection (4).

**Order details: Accessories**

**(1) Basic type**

	907031/90	Mounting bracket for duct version
	907031/91	Sheath for duct version
	907031/92	Mounting flange for duct version
	907031/93	Humidity sensor checks
x	<b>(2) Mounting bracket for duct version</b>	
	764	Wall bracket (black plastic)
	<b>(2) Sheath for duct version</b>	
x	797	wind shield (indoor and outdoor mounting)
x	798	sun and rain protection (outdoor mounting)
x	811	PTFE filter tube (2-sectional)
	<b>(2) Mounting flange for duct version</b>	
x	799	oval mounting flange (galvanized steel)
	<b>(2) Extra codes</b>	
x	820	33 % RH magnesium chloride
x	821	53 % RH magnesium nitride
x	822	76 % RH sodium chloride

Order code  (1) -  (2)  
 Order example 907031/90 - 764

**Stock versions**

Order code	Part No.
907031/90-764	90/60171300
907031/91-797	90/00323439
907031/91-798	90/00321186
907031/91-811	90/00491789
907031/92-799	90/60677200
907031/93-820	90/00332758
907031/93-821	90/00332759
907031/93-822	90/00332760