

POWERTECH

Solar Charge Controller with 2 USB Outlets

MP-3750, MP-3752

User Manual

1. Safety Information

- Read all of the instructions in the manual before installation.
- DO NOT disassemble or attempt to repair the controller.
- Install external fuse or breaker as required.
- Do disconnect the solar module and fuse/ breakers near to battery before installing or moving the controller.
- Power connections must remain tight to avoid excessive heating from a loose connection.
- Only charge batteries that comply with the parameters of controller.
- Battery connection may be wired to one battery or a bank of batteries.
- Risk of electric shock, the PV and load can produce high voltages when the controller is working.

2. Overview

PWM charge controller with USB output that adopts the most advanced digital technique. It's an easy operation and cost efficient controller featured as:

- 3-Stage intelligent PWM charging: Bulk, Boost/Equalize, Float
- Support 3 charging options: Sealed, Gel, and Flooded
- Battery status LED indicator can indicates battery situation
- Battery temperature compensation function
- The USB will provide power supply that can charge for electronic equipment
- Battery type and load output can be set via button
- Extensive Electronic protection

3. Product Features

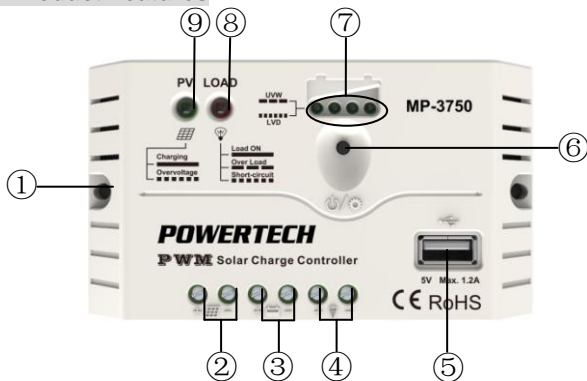

Figure 1 Product Feature

①	Mounting Hole Φ4.5	⑥	Button
②	PV Terminals	⑦	Battery status LED indicator
③	Battery Terminals	⑧	Load status LED indicator
④	Load Terminals	⑨	Charging status LED indicator
⑤	USB Output Port		

4. Wiring

(1) Connect components to the charge controller in the sequence as shown below and pay much attention to the “+” and “-”. Please don't insert the fuse or turn on the breaker during the installation.

(2) After power on the controller, check the Battery LED indicator on the controller, it will be on solid green. Otherwise please refer to chapter 8. Always connect the battery first, in order to allow the controller to recognize the system voltage.

(3) The battery fuse should be installed as close to battery as possible. The suggested distance is within 150mm.

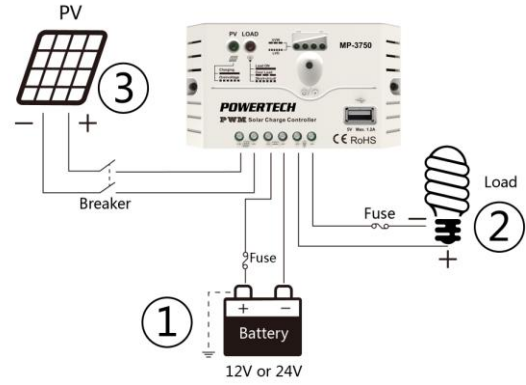

Figure 2 Connection diagram

5. LED Indicators

1) Charging and load status indicator

Indicator	Color	Status	Instruction
Charging status LED indicator	Green	On Solid	In Charging
	Green	OFF	No Charging
	Green	Fast Flashing	Battery Over Voltage
Load status LED indicator	Green	On Solid	Load ON
	Green	OFF	Load OFF
	Green	Slowly Flashing	Load over load
	Green	Fast Flashing	Load short circuit

2) Battery status indicator

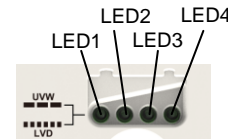

LED1	LED2	LED3	LED4	Battery Status
Slowly Flashing	X	X	X	Under voltage
Fast Flashing	X	X	X	Over discharge
Battery LED indicator status during voltage is up				
○	○	X	X	12.8V < U _{bat} < 13.4V
○	○	○	X	13.4V < U _{bat} < 14.1V
○	○	○	○	14.1V < U _{bat}
Battery LED indicator status during voltage is down				
○	○	○	X	12.8V < U _{bat} < 13.4V
○	○	X	X	12.4V < U _{bat} < 12.8V
○	X	X	X	U _{bat} < 12.4V

NOTE:

- ① Voltage value for 12V system at 25°C, please use 2x in 24V system ;
- ② "○"LED indicator on; "X"LED indicator off.

6. Setting Operation

1) Load ON/OFF Setting

When the controller is powered on, press the button to control the load output.

NOTE: The USB will output when the load is on.

2) Battery Type Setting

Operation:

Step 1: Enter setting mode by pressing button for 5s until the battery status LEDs are flashing.

Step 2: Select the desired mode by pressing button.

Step 3: The mode will be saved automatically without any operation for 5S and LED will stop flashing.

Battery Type Indicator

LED1	LED2	LED3	Battery type
○	X	X	Sealed(Default)
○	○	X	Gel
○	○	○	Flooded

NOTE: "○"LED indicator on "X"LED indicator off

7. Protection

- Battery Over Voltage Protection**
 When the battery voltage reaches to the set point of Over Voltage Disconnect Voltage(OVD), the controller will stop charging the battery to protect the battery from being over charged to break down.
- Battery Over Discharge Protection**
 When the battery voltage reaches to the set point of Low Voltage Disconnect Voltage(LVD), the controller will stop discharging the battery to protect the battery from being over discharged.
- Load Overload Protection**
 Load will be switched off when 1.25 times rated current overload happens. User has to reduce load appliance, then press the button or repower the controller.
- Load Short Circuit Protection**
 Load will be switched off when load short circuit (≥ 3 times rated current) happens. User has to clear short circuit, then press the button or repower the controller.
- High Voltage Transients Protection**
 The controller is protected against small high voltage transients. In lightning prone areas, additional external suppression is recommended.

8. Troubleshooting

Faults	Possible reasons	Troubleshooting
LED Charging indicator turn off during daytime when sunshine falls on PV modules properly	PV array disconnection	Confirm that PV and battery wire connections are correct and tight
No LED indicator	Battery voltage maybe less than 8V	Measure battery voltage with the multi-meter. Min.8V can start up the controller
Charging status LED indicator Fast flashing	Battery Over Voltage	Check if battery voltage is higher than OVD, and disconnect the PV
LED1 Fast flashing	Battery over discharged	When the battery voltage is restored to or above LVR point (low voltage reconnect voltage), the load will recover
Load status LED indicator slowly flashing	Load over load ^①	①Please reduce the number of electric equipments . ②Press the button or repower the controller.
Load status LED indicator fast flashing	Load short circuit	①Check carefully loads connection, clear the fault. ②Press the button or repower the controller.

①When load current reaches 1.25 times 1.5 times and 2 times 1.35-1.5 times more than nominal value, the controller will automatically turn off loads in 60s, 5s and 1s respectively.

9. Technical Specifications

Item	MP-3750	MP-3752
Nominal system voltage	12/24VDC Auto	
Rated charge current	10A	20A
Rated discharge current	10A	20A
Battery input voltage range	8V~32V	
Max. PV open circuit voltage	50V	
Self-consumption	12V \leq 5mA; 24V \leq 7mA	
Charge Circuit Voltage Drop	\leq 0.13V	
Discharge Circuit Voltage Drop	\leq 0.17V	
Temperature compensation coefficient	-5mV/ °C /2V	
USB Output Port	5VDC/1.2A	
Working environment temperature	-35 °C ~ +55 °C	
Humidity	\leq 95% N.C.	
Enclosure	IP20	
Grounding	Common Positive	
Overall dimension	120.3x67x21.8mm	148x85.6x34.8mm

Mounting dimension	111.5mm	138mm
Mounting hole size	Φ4.5	
Terminals	12AWG/4mm ²	10AWG /6mm ²
Net weight	0.10kg	0.18kg

Battery Voltage Control Parameters

Below parameters are in 12V system at 25 °C, please double the values in 24V system

Battery Type	Sealed	Gel	Flooded
Over Voltage Disconnect Voltage	16.0V	16.0V	16.0V
Charging Limit Voltage	15.0V	15.0V	15.0V
Over Voltage Reconnect Voltage	15.0V	15.0V	15.0V
Equalize Charging Voltage	14.6V	—	14.8V
Boost Charging Voltage	14.4V	14.2V	14.6V
Float Charging Voltage	13.8V	13.8V	13.8V
Boost Reconnect Charging Voltage	13.2V	13.2V	13.2V
Low Voltage Reconnect Voltage	12.6V	12.6V	12.6V
Under Voltage Warning Reconnect Voltage	12.2V	12.2V	12.2V
Under Voltage Warning Voltage	12.0V	12.0V	12.0V
Low Voltage Disconnect Voltage	11.1V	11.1V	11.1V
Discharging Limit Voltage	10.6V	10.6V	10.6V
Equalize Duration	120 min.	—	120 min.
Boost Duration	120 min.	120 min.	120 min.

10. Disclaimer

This warranty does not apply under the following conditions:

- Damage from improper use or use in an unsuitable environment.
- PV or load current, voltage or power exceeding the rated value of controller.
- User disassembly or attempted repair the controller without permission.
- The controller is damaged due to natural elements such as lightning.
- The controller is damaged during transportation and shipment.

11. Package Contents

MP-3750 / MP-3752 charge controller

User manual

Made in China

Any changes without prior notice! Version number: V1.8



 measure | control | record

1300 768 887

www.onetemp.com.au