

# RCSL/RCLL Install Guide

## Flexible Rogowski Current Sensor

Model	Rated Amps	Coil Inside Diameter	Maximum Continuous Amps
RCSL-1.5-0200	200 A	1.5 in (40 mm)	400 A
RCSL-3.1-0250	250 A	3.1 in (80 mm)	2000 A
RCSL-3.1-0600	600 A		
RCSL-3.1-1000	1000 A		
RCLL-4.7-1000	1000 A	4.7 in (120 mm)	2000 A
RCLL-4.7-2000	2000 A		
RCLL-7.8-1000	1000 A	7.8 in (200 mm)	5000 A
RCLL-7.8-2000	2000 A		
RCLL-11.8-2000	2000 A	11.8 in (300 mm)	5000 A
RCLL-11.8-5000	5000 A		

Figure 1: Model Table

### 1 Overview

The RCSL and RCLL series flexible Rogowski coil current sensors (RCxL) can monitor AC line current in circuits up to 600 Vac and nominal currents up to 5000 Amps. They can be opened and are flexible for ease of installation around bus bars and multiple conductors.

They are intended for field installation within distribution and control equipment such as panelboards, switchboards and industrial control equipment to measure the current on branch circuits and feeders.

RCxL sensors may be used with electric energy meters, like the WattNode<sup>®</sup> meters, or for other current measuring purposes.

Thin and lightweight, RCxL sensors have built-in integrating conditioning circuits to provide an output of 0.33333 Vac at rated current.

#### 1.1 Precautions

- ⚠ **Danger: Hazardous Voltages.** Potential shock hazard from dangerous high voltage exists.
- ⚠ **WARNING:** This product can expose you to chemicals including antimony trioxide, which is known to the State of California to cause cancer. For more information go to: [www.P65Warnings.ca.gov](http://www.P65Warnings.ca.gov).
- ⊗ Do not apply around or remove from HAZARDOUS LIVE conductors without additional protective equipment.

- Only qualified personnel or **licensed electricians** should install current sensors. The line voltages of 120 Vac to 600 Vac can be lethal!
- Install in accordance with ANSI/NFPA 70, “National Electrical Code” (NEC). Follow all local electrical codes.
- The RCxL is not suitable for Class 2 wiring methods and should not be connected to Class 2 equipment.
- Do not install RCxL sensors in the area of breaker arc venting or where they would block ventilation openings.
- Electrical codes prohibit installation of current sensors in equipment where they exceed 75% of the wiring space of any cross-sectional area.
- Do not install RCxL sensors where they may be exposed to excessive moisture, dust, salt spray, or other contamination.
- Do not install the RCxL sensors where they may be exposed to temperatures outside the operating range:
  - 40°C (-40°F) to +75°C (167°F) for the RCSL
  - 40°C (-40°F) to +75°C (167°F) for the RCLL-4.7 size
  - 40°C (-40°F) to +60°C (140°F) for the RCLL-7.8 and RCLL-11.8 sizes
- Rogowski coil current sensors measure alternating current (AC) only. They do not measure direct current (DC).
- If the equipment is used in a manner not specified by the manufacturer, the protection provided by the equipment may be impaired.

#### 1.2 Pre-Installation Checklist

- The RCSL or RCLL’s rated amps should normally be greater than or equal to the maximum current or breaker rating of the circuit being measured.
- To avoid damage to the coil, it should not be too tight around the conductor.
- It is preferable to install the sensor and meter close to each other. However, you may extend the output cable up to 100 feet (30 m) using a four-conductor shielded twisted-pair cable and by running the lead wires away from high current and line voltage conductors.

#### 1.3 Components

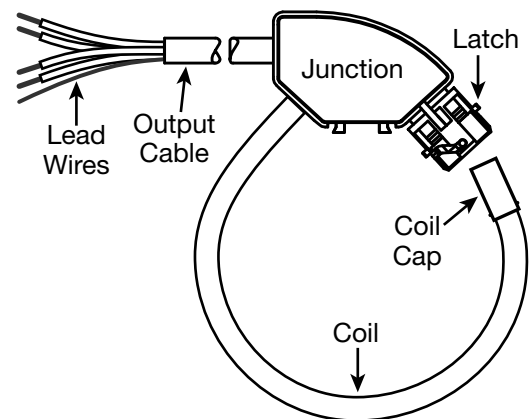

Figure 2: RCxL Diagram

The RCxL series Rogowski coil current sensors include the following components:

- Coil:** the Rogowski coil senses the current. It is a flexible gray coil.
- Coil cap:** this is the cylindrical black cap on one end of the coil.
- Junction:** this is the black plastic housing that holds the ends of the coil together, contains the conditioning circuitry, and connects the output cable.
- Output cable:** this is the black shielded cable that runs from the coil to the meter and power supply.
- Lead wires:** the individual wires in the output cable, two for the signal, two for DC power, and one shield.

RCxL sensors require a DC power supply, which must be ordered separately.

## 2 Connecting the RCxL

**WARNING: To reduce the risk of electric shock, always open or disconnect the circuit from the power distribution system (or service) of the building before installing or servicing current sensors.**

- 1) To open the RCxL, twist the locking ring counterclockwise until it unlatches the cap, then gently pull the removable coil end free (very little force should be required).

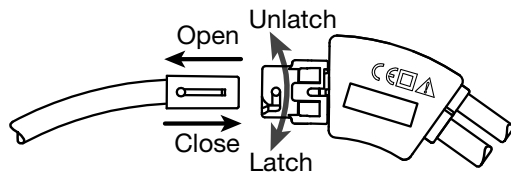

**Figure 3: Open the RCLL Coil**

- 2) Place the coil around the primary conductor, group of conductors, or busbar.
- 3) Be sure to point the label marking “This side towards load” facing the current load. Note: If the coil is mounted backwards, the measured power will be negative.
- 4) Close the coil by inserting the coil cap into the junction (rotate if needed for proper alignment). Twist the locking ring clockwise until it latches (about a quarter turn).
- 5) *Optional:* Secure the RCxL to the conductor with a cable tie.
- 6) Route the output wires to the meter or measurement device. **Be sure to route the output wires so that they do not directly contact live terminals or bus bars.**
- 7) Connect the white and black output wires to the color-coded terminals on the meter.
- 8) Connect the bare shield wire to the meter earth ground.

## 3 Connect the Power Supply

### 3.1 General

The RCLS and RCLL power connections are polarity sensitive, so the positive power supply wire must be connected to the positive power supply terminal.

If you need to power multiple RCxLs, you may connect the power lead wires using wire nuts, terminal strips, or other wire splicing devices. Each RCxL draws 6-20 mA, so the recommended power supply can easily power 50 RCxL sensors.

If you are not using a supply provided by CCS, adapt the directions below or contact CCS technical support for assistance.

**The supply and supply wires must not come in contact with hazardous voltages on live terminals or busses.**

### 3.2 HDR-15-5 Power Supply

The HDR-15-5 supply should be DIN rail mounted. It provides screw terminal connections for both the line Vac input connections: neutral **N**, and line **L**; and for the output connections: **+V** and **-V**.

- If you need to power multiple RCxLs, you may connect all the +V power leads together and all the -V leads using wire nuts, terminal strips, or other wire splicing devices and power them all from one supply.
- Connect neutral **N**, and line **L** to a 100 to 240 Vac branch circuit with overcurrent protection (fuse or circuit breaker). Use 18 AWG to 14 AWG wire.
- Connect the **+V** terminal to the red RCxL lead wire.
- Connect the **-V** terminal to the blue RCxL lead wire.

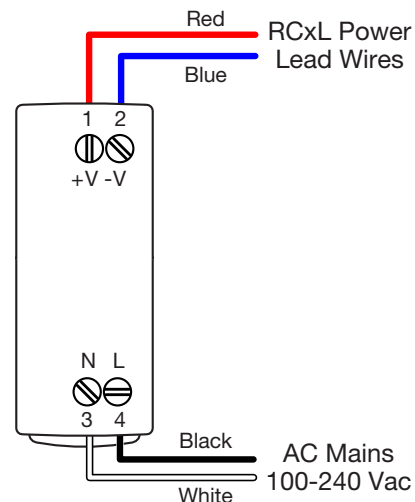

**Figure 4: Power Supply Connection**

## 4 Installation Notes

- If the white and black output lead wires of the RCxL are reversed, the measured power will be negative.
- When connecting to a WattNode meter, align the white RCxL lead wire with the white dot on the label, and the black lead wire with the black dot on the label.
- Be careful to match the coil to the voltage phases being measured. Make sure the **ØA**, **V<sub>A</sub>**, or **L1** coil measures the current on the **ØA**, **V<sub>A</sub>**, or **L1** conductor, and the same for phases B and C. Use colored labels or tape to identify the wires.

## 4.1 Accuracy Notes

There are several factors that may affect the accuracy of RCxL current sensors.

- Avoid forcefully twisting, pulling, or hitting the RCxL coil as this may damage the coil or degrade the accuracy.
- For best accuracy position the junction housing away from any other line conductors and away from the conductors being measured if there is slack in the coil.
- RCxL coils do not interfere with each other and may be installed in contact with other RCxL coils.
- If possible, avoid locating the coil near corners or sharp bends in the conductor being monitored.
- Current flowing through nearby external conductors can degrade the accuracy (both gain and phase). For best accuracy, choose an RCxL size that is not too large, and keep the coil positioned away from external conductors as much as possible.
- VFD (variable frequency drive) noise may degrade the RCxL accuracy, especially at low currents. To minimize this, try to locate the RCxL as far as possible from the VFD unit. Never put the RCxL coil around the wires connecting the output of a VFD to the motor.
- The readings may vary up to  $\pm 0.5\%$  over the full temperature range. Near room temperature, the variation is much smaller. The phase angle is not affected by temperature.
- If possible, avoid extending the output cable, as the signal is low amplitude and may be susceptible to interference.

## 5 References

For more information about current transformers and current sensors, see: <https://ctlsys.com/cat/current-transformer/>.

For more information about connecting current sensors to WattNode meters, see the appropriate WattNode meter manual.

## 6 Specifications

**Type:** Flexible Rogowski coil current sensor with internal conditioning circuit

### 6.1 Models

See **Figure 1: Model Table**

### 6.2 Electrical

**Output wires:** 8 feet (2.4 m), 24 AWG, twisted

**White:** current sensor positive (in-phase with current) signal

**Black:** current sensor negative (180 degree phase to current) signal

**Red:** DC supply voltage positive

**Blue:** DC supply voltage ground

**Bare (tin):** shield

**Primary Frequency:** 50/60 Hz nominal (safe to operate at any frequency)

**Maximum primary voltage:** 600 Vac

**Maximum primary current:** see **Figure 1: Model Table**

**Secondary voltage:** 0.33333 Vac at rated primary current, 1.00 Vac maximum

**Overvoltage category:** CAT IV, 600 Vac, service entrance

**DC power:** 3.5 Vdc to 13.5 Vdc (5 Vdc or 12 Vdc recommended), 6 mA typical, 20 mA maximum

**UL recognized:** file number E363660 (XOBA, XOBA7), UL 2808 and CAN/CSA-C22.2 No. 61010-1

### 6.3 Accuracy

See *datasheet*

### 6.4 Environmental

**Operating temperature:**

**RCSL-1.5 and RCSL-3.1:**  $-40^{\circ}\text{C}$  to  $+75^{\circ}\text{C}$  ( $-40^{\circ}\text{F}$  to  $167^{\circ}\text{F}$ )

**RCLL-4.7:**  $-40^{\circ}\text{C}$  to  $+75^{\circ}\text{C}$  ( $-40^{\circ}\text{F}$  to  $167^{\circ}\text{F}$ )

**RCLL-7.8 and RCLL-11.8:**  $-40^{\circ}\text{C}$  to  $+60^{\circ}\text{C}$  ( $-40^{\circ}\text{F}$  to  $140^{\circ}\text{F}$ )

**Operating humidity:** 0 to 95% relative humidity (RH)

**Pollution:** POLLUTION DEGREE 2

**Indoor use:** Suitable for indoor use.

### 6.5 Mechanical

**Dimensions:**

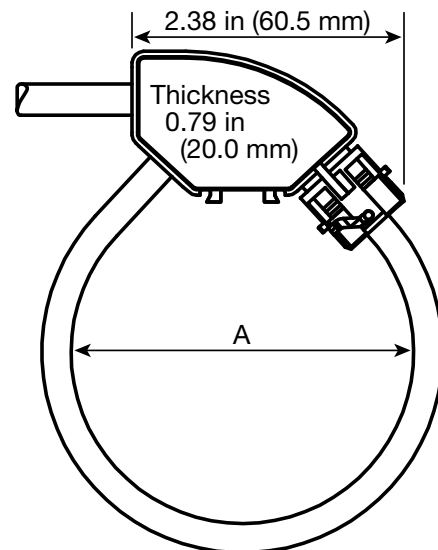

**Figure 5: RCSL Dimensional Drawing**

Dimension	RCSL-1.5	RCSL-3.1
A	1.57 in (40 mm)	3.15" (80 mm)
Coil diameter	0.283 $\pm$ 0.008 in (7.2 $\pm$ 0.2 mm)	
Coil end cap diameter	0.408 in (10.35 mm)	

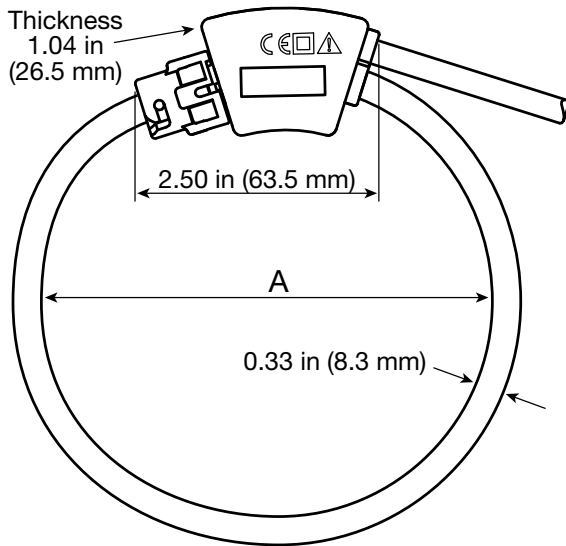

**Figure 6: RCLL Dimensional Drawing**

Dimension	RCLL Family		
	RCLL-4.7	RCLL-7.8	RCLL-11.8
A	4.7 in (120 mm)	7.8 in (200 mm)	11.8 in (300 mm)
Coil end cap diameter	0.443 in (11.25 mm)		

### 6.6 Power Supply

The RCSL and RCLL may be purchased with the following power supply:

**Mean-Well Industrial:** HDR-15-5

You may use alternate supplies, subject to the following:

**Output voltage:** 4 – 12 Vdc

**Output current:** at least 20 mA per RCxL

## 7 Warranty

The RCSL and RCLL products sold by Continental Control Systems, LLC (CCS) are guaranteed against defects in material and workmanship for a period of five years from the original date of shipment. CCS's responsibility is limited to repair, replacement, or refund, any of which may be selected by CCS at its sole discretion. CCS reserves the right to substitute functionally equivalent new or serviceable used parts.

This warranty covers only defects arising under normal use and does not include malfunctions or failures resulting from: misuse, neglect, improper application, improper installation, water damage, acts of nature, lightning, product modifications, alterations or repairs by anyone other than CCS.

Except as set forth herein, CCS makes no warranties, expressed or implied, and CCS disclaims and negates all other warranties, including without limitation, implied warranties of merchantability and fitness for a particular purpose.

### 7.1 Limitation of Liability

**In no event shall CCS be liable for any indirect, special, incidental, punitive or consequential damages of any kind or nature arising out of the sale or use of its products whether such liability is asserted on the basis of contract, tort or otherwise, including without limitation, lost profits, even if CCS has been advised of the possibility of such damages.**

**Customer acknowledges that CCS's aggregate liability to Customer relating to or arising out of the sale or use of CCS's products, whether such liability is asserted on the basis of contract, tort or otherwise, shall not exceed the purchase price paid by Customer for the products in respect of which damages are claimed. Customer specifically acknowledges that CCS's price for the products is based upon the limitations of CCS's liability set forth herein.**

**OneTemp**<sup>o</sup> pty ltd  
 measure | control | record  
**1300 768 887**  
[www.onetemp.com.au](http://www.onetemp.com.au)