

Ammonia-sensitive sensor for ammonia measurements in aqueous solutions

Brief description

This sensor can be used to measure ammonia (NH₃) in aqueous solutions. In an aqueous solution, ammonia is in a pH-dependent equilibrium with ammonium ions (NH₄⁺ ions). Provided the NH₄⁺ ions are converted into ammonia by adding lye, the sensor also detects the resultant ammonia. The NH₄⁺ ions themselves are not detected.

The ammonia sensor consists of a pH glass electrode and a reference electrode. Both the electrodes are in an electrolyte. The electrolyte is separated from the process medium by a hydrophobic, gas-permeable membrane. The pH value of the electrolyte changes if NH₃ gas diffuses through the hydrophobic membrane. This local change in the pH value is measured at high resistance by the integrated pH electrode.

JUMO ammonia sensors feature the advantage of having ready-made membrane caps. There is no need to put the sensitive membrane on by hand. With the JUMO sensor, the membrane cap is quickly and easily replaced as a complete unit.

Monitoring ammonia leakage in refrigerating plants

Refrigerating plants (in indoor ice rinks or cold storage, for example) frequently use ammonia as a refrigerant. As ammonia (NH₃) is a toxic, pungent-smelling, colorless gas, the plants are monitored for escaping ammonia (leakage). Gas sensors are used to monitor the ambient air (these are not supplied by JUMO). In addition, the pipes and system components that carry the liquids are monitored for ammonia ingress. JUMO's ammonia-sensitive sensor can be used for this purpose. Measuring ammonia with a JUMO ammonia sensor gives a far more selective response than measuring the pH. The JUMO ammonia sensor can also be used in online analyzers/samplers or in the laboratory.

More information can be found in JUMO white paper 631, "Information on measuring ammonia in water".



Type 201040

Technical data

Analyte ^a	NH ₃
Measuring range	0.01 to 9,999 ppm (mg/l) NH ₃
Temperature range	
Standard	0 to 50 °C
For low temperature (extra code 854)	-8 to +30 °C
pH range	7.5 to 14
Length	120 mm
Diameter	12 mm
Connection	Pg13.5 screw-on head
Medium pressure	
Installed in quick-change fitting, part no. 00379538	2 to 3 bar (max.6 bar)
Not installed	1 bar abs. (atmospheric pressure)
Membrane cap material	Special PTFE
Suitable transmitters	JUMO AQUIS 500 pH, see data sheet 202560 JUMO dTRANS pH 02, see data sheet 202551

^a The sensor is used to detect NH₃ ammonia. It must not be used as a sensor for continuous measurement of NH₃ ammonia.



Operating range

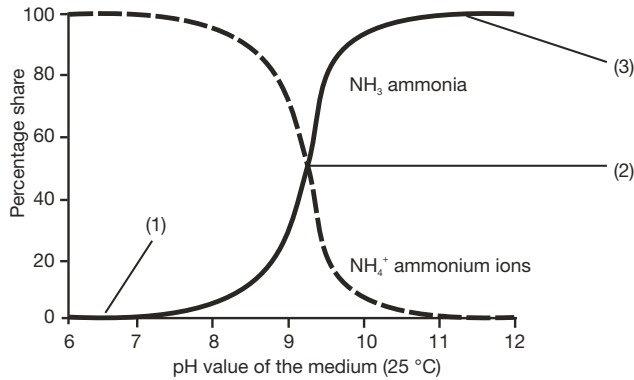

- (1) Only NH_4^+ ions (ammonium) present
- (2) The ratio of NH_4^+ ions (ammonium) and NH_3 (ammonia) is 1:1
- (3) Only NH_3 ions present

Notes

The presence of ammonia in the sample medium is heavily dependent on its pH value (see diagram "Operating range").

Ammonium ions (NH_4^+) predominate in the acidic range and are not detected by the sensor!

At a pH of approximately 9.3, the concentration ratio of ammonia (NH_3) and ammonium (NH_4^+) is about 1:1.

Ammonia is only dominant in the reaction in the heavily alkaline range.

The process medium must not contain any substances that could damage the sensor membrane (e.g. oils, greases, dirt particles or surfactants)

The sensor element of the ammonia-sensitive sensor is a pH glass membrane with a high internal resistance. Due to the principle, the resistance of the glass membrane increases with decreasing temperature.

Other important factors influencing the signal quality of the measurement chain are the insulation resistance of the sensor cable and the plug connection. **In order to avoid external interference, from certain temperatures (< 10 °C) and cable lengths (> 15 m) it may make sense to make the signal more low-impedance by using an impedance converter (part no. 00300455).**

Dimensions

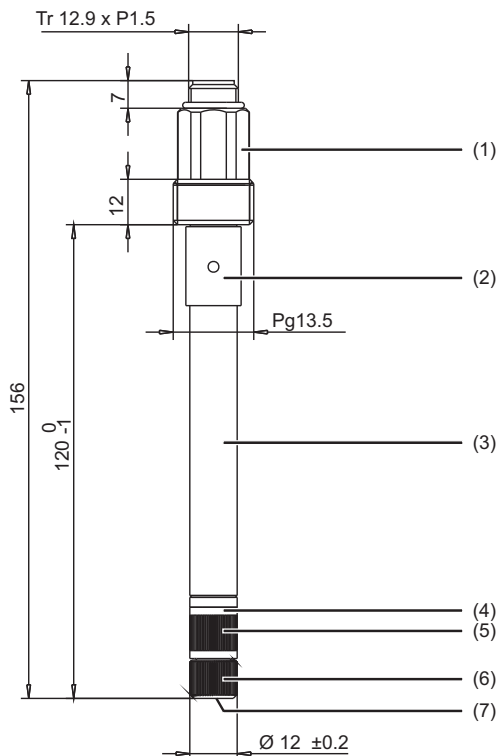

- (1) Pg 13.5 screw-on head
- (2) Hose connection (silicone)
- (3) Shaft (PPO)
- (4) O-ring (FPM)
- (5) Sleeve (PSU)
- (6) Membrane cap (stainless steel 1.4571)
- (7) Membrane (PTFE)

JUMO GmbH & Co. KG
 Delivery address: Mackenrodtstraße 14
 36039 Fulda, Germany
 Postal address: 36035 Fulda, Germany
 Phone: +49 661 6003-0
 Fax: +49 661 6003-607
 Email: mail@jumo.net
 Internet: www.jumo.net

JUMO Instrument Co. Ltd.
 JUMO House
 Temple Bank, Riverway
 Harlow, Essex CM 20 2DY, UK
 Phone: +44 1279 63 55 33
 Fax: +44 1279 62 50 29
 Email: sales@jumo.co.uk
 Internet: www.jumo.co.uk

JUMO Process Control, Inc.
 6733 Myers Road
 East Syracuse, NY 13057, USA
 Phone: +1 315 437 5866
 Fax: +1 315 437 5860
 Email: info.us@jumo.net
 Internet: www.jumousa.com



Accessories

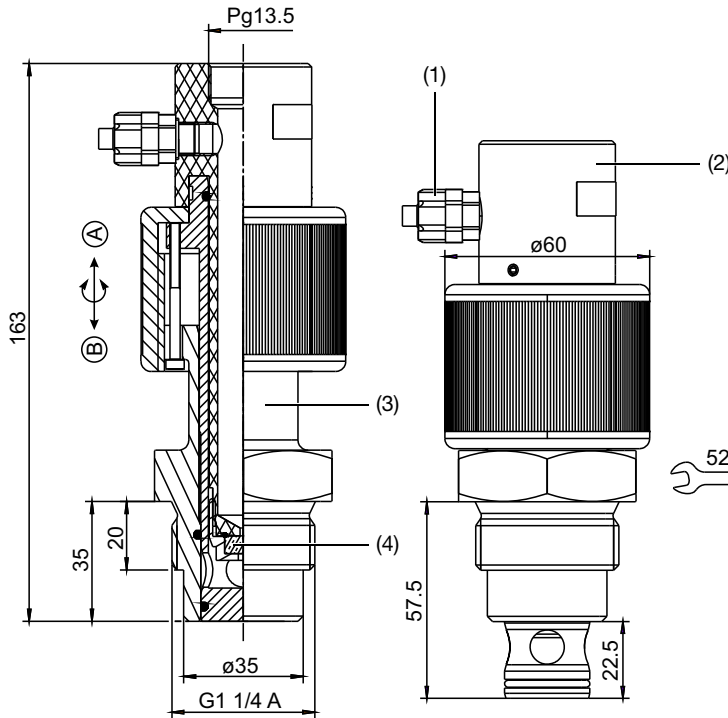

- (1) G 1/8 A (POM) hose connection
- (2) Material PP
- (3) Shaft (PPO)
- (4) Replaceable PTFE washer
- (A) Closed
- (B) Open

Manual quick-change fitting	Part no.: 00379538
Optimum operating pressure	2 to 4 bar
Maximum operating pressure	6 bar
Operating temperature	-8 to +50 °C

The purpose of the manual quick-change fitting is to hold the ammonia sensor. It protects the sensor against excessively high pressures during operation and limits the flow rate of the process medium through the measurement chamber.

The throughput of measuring fluid depends on the viscosity and temperature of the medium and the pressure in the line it flows through. PTFE washers for normal flow rate (white) or increased flow rate (black) are available as accessories.

Order details

(1) Basic type	
201040/65	Ammonia sensor
(2) Connection	
22	Pg13,5 screw-on head
(3) Insertion length	
120	120 mm (standard)
(4) Extra codes	
000	None
854	Low-temperature electrolyte

Order code	(1)	-	(2)	-	(3)	/	(4)
Order example	201040/65	-	22	-	120	/	000

Note:

The type code is not a modular system.

If possible, choose items listed under "**stock versions**" or "**production versions**" for your orders.

We will have to technically inspect and approve a free combination of individual key features.

Stock versions

(delivery 3 working days after receipt of order)

Type	Brief description	Part no.
201040/65-22-120/000	Ammonia sensor, Pg13.5 screw-on head, 120 mm	00440655
201040/65-22-120/854	Ammonia sensor, Pg13.5 screw-on head, 120 mm for use in highly concentrated refrigerants, -8 to +30 °C	00478869

Accessories

Type	Part no.
Quick-change fitting for ammonia sensor	00379538
Maintenance kit for ammonia sensor (standard)	00449637
Maintenance kit for ammonia sensor (code 854, temperature electrolyte)	00477746
Transmitter/controller JUMO AQUIS 500 pH	00480051
PTFE washers for manual quick-change fitting (standard, white, 3 washers)	00583477
PTFE washers for manual quick-change fitting (increased flow rate, black, 3 washers)	00583479