

PROMUX

Distributed MODBUS I/O Modules



Catalog and Design Guide

Disclaimer

Procon Electronics makes no representations or warranties with respect to the contents hereof. In addition, information contained herein are subject to change without notice. Every precaution has been taken in the preparation of this manual. Nevertheless, Procon Electronics assumes no responsibility, express or implied, for errors or omissions or any damages resulting from the use of the information contained in this publication.

All trademarks belong to their respective owners.

TABLE OF CONTENTS

1.	AN OVERVIEW OF THE PROMUX SYSTEM	7
1.1	INTRODUCTION	7
1.2	APPLICATION CONFIGURATIONS	7
1.2.1	Simple Point to Point I/O.....	7
1.2.2	Complex Point to Point I/O.....	8
1.2.3	I/O Expansion.	8
1.2.4	Data Acquisition.	9
1.2.5	Ethernet.....	9
1.2.6	Other Applications.....	9
1.3	MODULE SELECTION TABLE	10
2.	PROMUX GENERAL INFORMATION.....	11
2.1	PHYSICAL DIMENSIONS	11
2.2	GROUNDING/SHIELDING.....	11
2.3	NETWORK TERMINATION.....	11
2.4	RS485 NETWORK WIRING.....	12
2.5	RS485 NETWORK PROTECTION.....	13
2.6	SETTING THE MODBUS NODE ID.....	14
2.6.1	Node ID Table	14
2.6.2	DIP Switch Status Register.....	17
2.7	COMMUNICATIONS SETTINGS	17
2.7.1	Communications Settings with DIP Switch 10 Off (Default)	17
2.7.2	Communications Settings with DIP Switch 10 On (Programmed Baud Rate)....	17
2.7.3	Communications Settings Registers	17
2.7.4	Modbus Register Types	18
2.7.5	Modbus Functions.....	18
3.	PROMUX MODULES	19
3.1	PM16DI - DIGITAL INPUTS WITH COUNTERS	19
3.1.1	Description	19
3.1.2	Technical Specification of PM16DI	19
3.1.3	Status Indicators	20
3.1.4	Wiring.....	20
3.1.5	Switch Settings	21
3.1.6	PM16DI Data Registers (MODULE TYPE = 100).....	22
3.2	PM16DI110 - DIGITAL INPUTS WITH COUNTERS	27
3.2.1	Description	27
3.2.2	Technical Specification of PM16DI110	27
3.2.3	Status Indicators	28
3.2.4	Wiring.....	28
3.2.5	Switch Settings	29
3.2.6	PM16DI110 Data Registers (MODULE TYPE = 115).....	30
3.3	PM16DI220 - DIGITAL INPUTS WITH COUNTERS	35
3.3.1	Description	35
3.3.2	Technical Specification of PM16DI220	35
3.3.3	Status Indicators	36
3.3.4	Wiring.....	36
3.3.5	Switch Settings	37
3.3.6	PM16DI220 Data Registers (MODULE TYPE = 116).....	38
3.4	PM16DO - DIGITAL OUTPUTS.....	43
3.4.1	Description	43
3.4.2	Technical Specification of PM16DO	43
3.4.3	Status Indicators	44
3.4.4	Wiring.....	44

3.4.5	Switch Setting	45
3.4.6	PM16DO Data Registers (MODULE TYPE = 101)	46
3.4.7	Modbus Master Setup	47
3.6	PM16DOP - DIGITAL OUTPUTS	49
3.6.1	Description	49
3.6.2	Technical Specification of PM16DOP	49
3.6.3	Status Indicators	50
3.6.4	Wiring	50
3.6.5	Switch Setting	51
3.6.6	PM16DOP Data Registers (MODULE TYPE = 101)	52
3.6.7	Modbus Master Setup	53
3.7	PM4RO - RELAY OUTPUTS	55
3.7.1	Description	55
3.7.2	Technical Specification of PM4RO	55
3.7.3	Status Indicators	56
3.7.4	Wiring	56
3.7.5	Switch Setting	57
3.7.6	PM4RO Data Registers (MODULE TYPE = 113)	58
3.7.7	Modbus Master Setup	59
3.8	PM8DIO - DIGITAL INPUTS / OUTPUTS	61
3.8.1	Description	61
3.8.2	Technical Specification of PM8DIO	62
3.8.3	Status Indicators	62
3.8.4	Wiring	63
3.8.5	Switch Settings	63
3.8.6	Setting the jumpers for NPN inputs.	64
3.8.7	Setting the jumpers for PNP inputs	64
3.8.8	PM8DIO Data Registers (MODULE TYPE = 102)	65
3.8.9	Modbus Master Setup	67
3.9	PM8DIO-24VAC - DIGITAL INPUTS / OUTPUTS	69
3.9.1	Description	69
3.9.2	Technical Specification of PM8DIO-24VAC	70
3.9.3	Status Indicators	70
3.9.4	Wiring	71
3.9.5	Switch Settings	71
3.9.6	Setting the jumpers for NPN inputs.	72
3.9.7	Setting the jumpers for PNP inputs	72
3.9.8	PM8DIO-24VAC Data Registers (MODULE TYPE = 102)	73
3.9.9	Modbus Master Setup	75
3.10	PM8AI/I AND PM8AI/V - ANALOG INPUTS	77
3.10.1	Description	77
3.10.2	Technical Specification of PM8AI/I and PM8AI/V	77
3.10.3	Status Indicators	78
3.10.4	Wiring	78
3.10.5	Switch Settings	79
3.10.6	PM8AI Data Registers (PM8AI/I TYPE = 103 / PM8AI/V TYPE = 104)	80
3.11	PM8AI/I ISO AND PM8AI/V ISO - ISOLATED ANALOG INPUTS	83
3.11.1	Description	83
3.11.2	Technical Specification of PM8AI/I ISO and PM8AI/V ISO	84
3.11.3	Status Indicators	85
3.11.4	Wiring	85
3.11.5	Switch Settings	86
3.11.6	PM8AI ISO Data Registers (8AI/I TYPE = 107/8AI/V TYPE = 108)	87
3.12	PM8TC - THERMOCOUPLE INPUTS	91
3.12.1	Description	91
3.12.2	Technical Specification of PM8TC	92
3.12.3	Status Indicators	92
3.12.4	Wiring	93
3.12.5	Switch Settings	93
3.12.6	PM8TC Data Registers (MODULE TYPE = 105)	94

3.13	PM8TCISO - ISOLATED THERMOCOUPLE INPUTS	95
3.13.1	Description	95
3.13.2	Technical Specification of PM8TC	96
3.13.3	Status Indicators	96
3.13.4	Wiring	97
3.13.5	Switch Settings	97
3.13.6	PM8TCISO Data Registers (MODULE TYPE = 106)	98
3.14	PM6RTD - RTD INPUTS.....	100
3.14.1	Description	100
3.14.2	Technical Specification of PM6RTD	101
3.14.3	Status Indicators	101
3.14.4	Wiring	102
3.14.5	Switch Settings	102
3.14.6	PM6RTD Data Registers (MODULE TYPE = 109).....	103
3.15	PMDAIO – DIGITAL + ANALOG INPUTS AND OUTPUTS	104
3.15.1	Description	104
3.15.2	Technical Specification of PMDAIO	106
3.15.3	Status Indicators	107
3.15.4	Wiring	108
3.15.5	Switch Settings	108
3.15.6	Setting the jumpers for Current Input and Output.....	109
3.15.7	Setting the jumpers for Voltage Input and Output.	109
3.15.8	PMDAIO Data Registers (MODULE TYPE = 112)	110
3.16	PMDAIO2 – DIGITAL + ANALOG INPUTS AND OUTPUTS TYPE 2	112
3.16.1	Description	112
3.16.2	Technical Specification of PMDAIO2.....	114
3.16.3	Status Indicators	115
3.16.4	Wiring	116
3.16.5	Switch Settings	116
3.16.6	Setting the jumpers for Current Input.....	117
3.16.7	Setting the jumpers for Voltage Input.	117
3.16.8	PMDAIO2 Data Registers (MODULE TYPE = 119)	118
3.16.9	Modbus Master Setup.....	121
3.17	PM8AO - ANALOG OUTPUTS	122
3.17.1	Description	122
3.17.2	Technical Specification of PM8AO	122
3.17.3	Status Indicators	123
3.17.4	Wiring	123
3.17.5	Switch Settings	124
3.17.6	PM8AO Data Registers (MODULE TYPE = 110)	125
3.17.7	Modbus Master Setup.....	125
3.18	PM8VO - ANALOG OUTPUTS	126
3.18.1	Description	126
3.18.2	Technical Specification of PM8VO	126
3.18.3	Status Indicators	127
3.18.4	Wiring	127
3.18.5	Switch Settings	128
3.18.6	PM8VO Data Registers (MODULE TYPE = 111)	129
3.18.7	Modbus Master Setup.....	129
3.19	PMIOMAP - I/O MAPPER	130
3.19.1	Description	130
3.19.2	Technical Specification of PMIOMAP	130
3.19.3	Status Indicators	131
3.19.4	Wiring	131
3.19.5	Switch Setting	131
3.19.6	PMIOMAP Data Registers (MODULE TYPE = 114).....	132
3.19.7	Modbus Master Setup.....	132
3.20	PMIOMAPTYPE2 - I/O MAPPER TYPE 2.....	134
3.20.1	Description	134
3.20.2	Technical Specification of PMIOMAPTYPE2.....	134

3.20.3	Status Indicators	135
3.20.4	Wiring.....	135
3.20.5	Switch Setting	135
3.20.6	PMIOMAPTYPE2 Data Registers (MODULE TYPE = 117)	136
3.20.7	Modbus Master Setup.....	136
3.21	PM485REP – ISOLATED RS232/RS485 TO RS485 REPEATER	138
3.21.1	Description	138
3.21.2	Technical Specification of PM485REP	138
3.21.3	Status Indicators	139
3.21.4	Wiring.....	139
3.21.5	Switch Setting	140
3.21.6	Setting the jumpers for RS485.....	141
3.21.7	Setting the jumpers for RS232.....	141
3.22	PMFIBRE – RS232/RS485 TO FIBRE.....	142
3.22.1	Description	142
3.22.2	Technical Specification of PMFIBRE	142
3.22.3	Status Indicators	143
3.22.4	Wiring.....	143
3.22.5	Switch Setting	143
3.22.6	Setting the jumpers for RS485.....	144
3.22.7	Setting the jumpers for RS232.....	144
3.22.8	Order Codes.	144
4.	SPECIFICATIONS.....	145
4.1	ENVIRONMENTAL	145
4.2	EMC INSTALLATION INSTRUCTIONS.....	145
4.3	CONFORMITY CERTIFICATE.....	146
4.4	EMC TEST RESULTS	147

1. AN OVERVIEW OF THE PROMUX SYSTEM

1.1 Introduction

PROMUX is an innovative modular I/O system which provides a simple low cost solution for distributed I/O requirements.

The PROMUX system consists of stand-alone Digital and Analog Input and Output modules which are connected together on a **RS485** two wire multi-drop network.

The modules communicate using the **MODBUS RTU** protocol. A 32bit ARM CPU is used in the modules to provide high speed data processing and fast communications turnaround times. Multiple baud rates are selectable from 2400 to 115200 baud.

All PROMUX modules plug directly onto an industry standard DIN rail. All modules have a minimum isolation of 1000VAC rms between the field and logic.

The modules have been equipped with status led's which are used to indicate the status of the Inputs or outputs. This visual indication assists with fault finding and diagnostics.

1.2 Application Configurations

There are a number of different configurations in which the PROMUX modules may be used in a system. Some are listed as follows:

1.2.1 Simple Point to Point I/O.

This is the basic configuration where a maximum of **8 Digital or Analog Inputs** will be transmitted to **8 Digital or Analog Outputs** at a remote location on the network. The primary advantage of this configuration is cost saving where 9 wires are replaced by a single twisted pair. It may also be used on existing installations to avoid having to install additional cabling for expansion purposes. When the PM8DIO modules are used bi-directional data is sent between the modules.

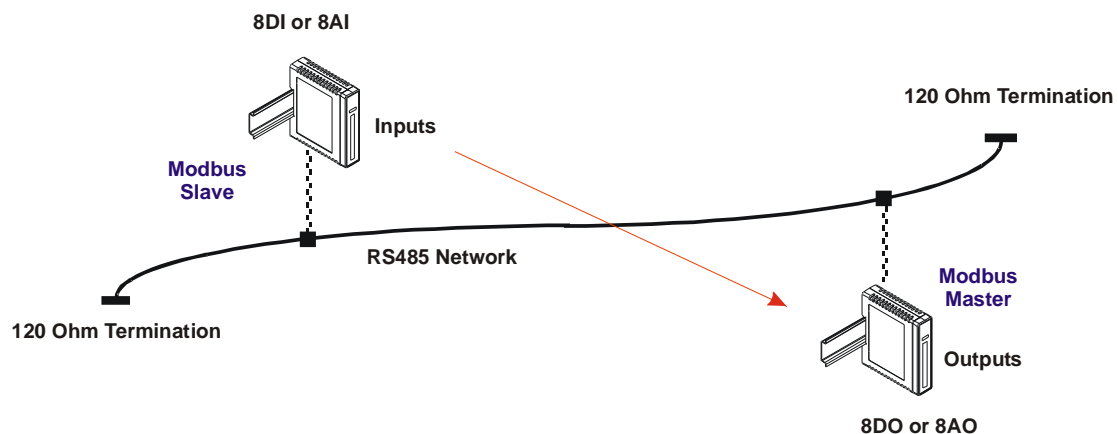

Modules that support the point to point mode are:

1. PM16DI to PM16DO
2. PM16DI to 4 x PM4RO
3. PM8DIO to PM8DIO
4. PM8AI/I (or PM8AI/V) to PM8AO
5. PM8AI/I (or PM8AI/V) to PM8VO
6. PMDAIO2 to PMDAIO2

1.2.2 Complex Point to Point I/O.

This configuration allows for a larger number of I/O to be connected to the network at random points on the network. A maximum of 16 Digital Input Modules and 8 Analog Modules may be placed on the network, and the inputs are transmitted to a corresponding number of Digital or Analog Output Modules. In this configuration the Modules are set to operate in the MODBUS Slave mode and a Master Module called an **I/O MAPPER** is used to transmit the Inputs from the Input Modules to the Outputs on the Output Modules.

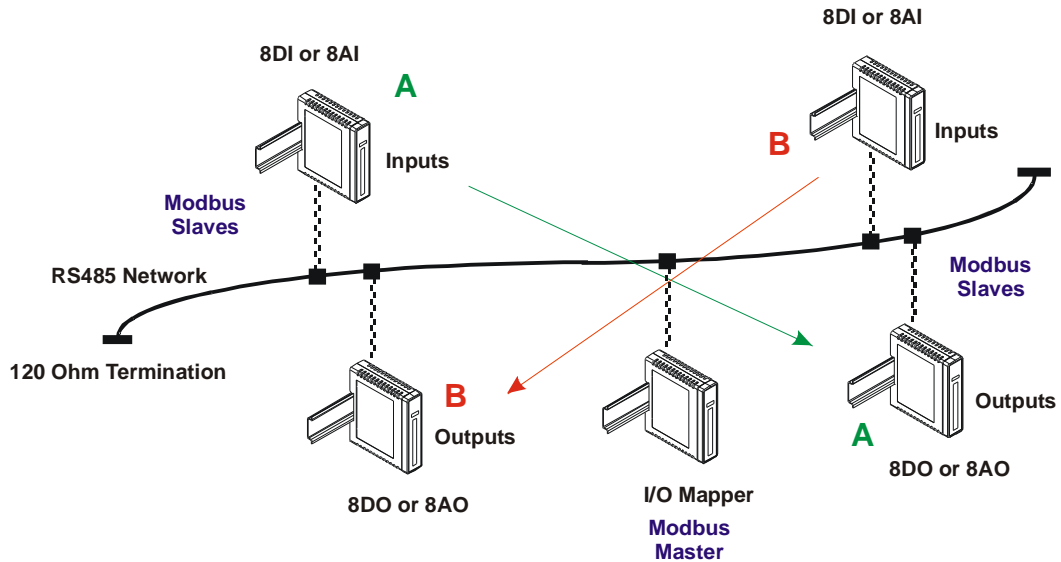

1.2.3 I/O Expansion.

There are a number of devices such as **PLC's** (Programmable Logic Controllers) which have a MODBUS Communications facility available. When configured as a MODBUS Master, and attached to the RS485 network, the PLC can use the PROMUX Modules as remote I/O reducing cabling costs and increasing the I/O capability of the PLC.

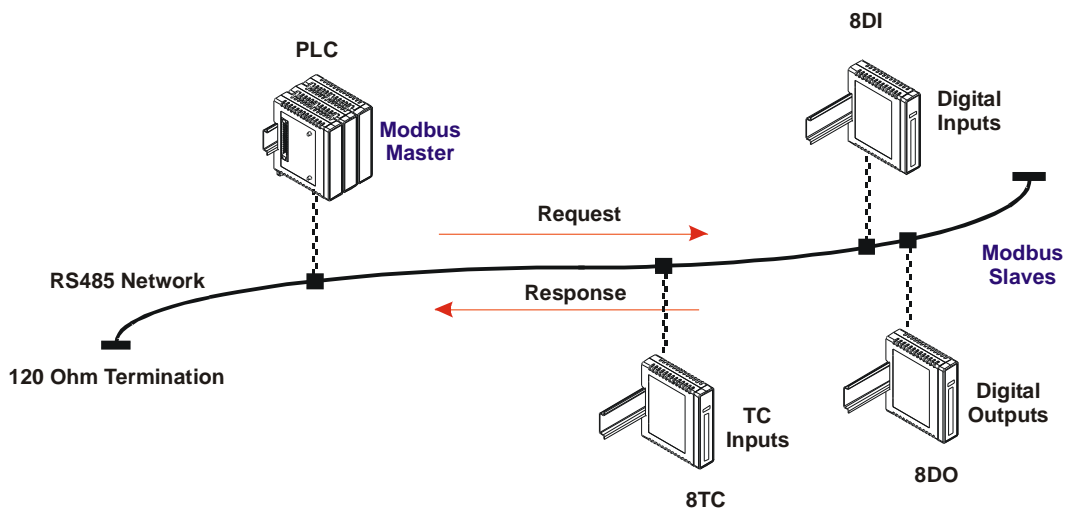

1.2.4 Data Acquisition.

Another use of the PROMUX Modules is for Data Acquisition where a PC (Personal Computer) is connected to the Network. Many SCADA software packages support the MODBUS Master Protocol and can hence retrieve data from Input Modules or send data to Output Modules. The **serial port** of the PC is connected to an **RS232/RS485 Converter** which in turn is connected to the Network.

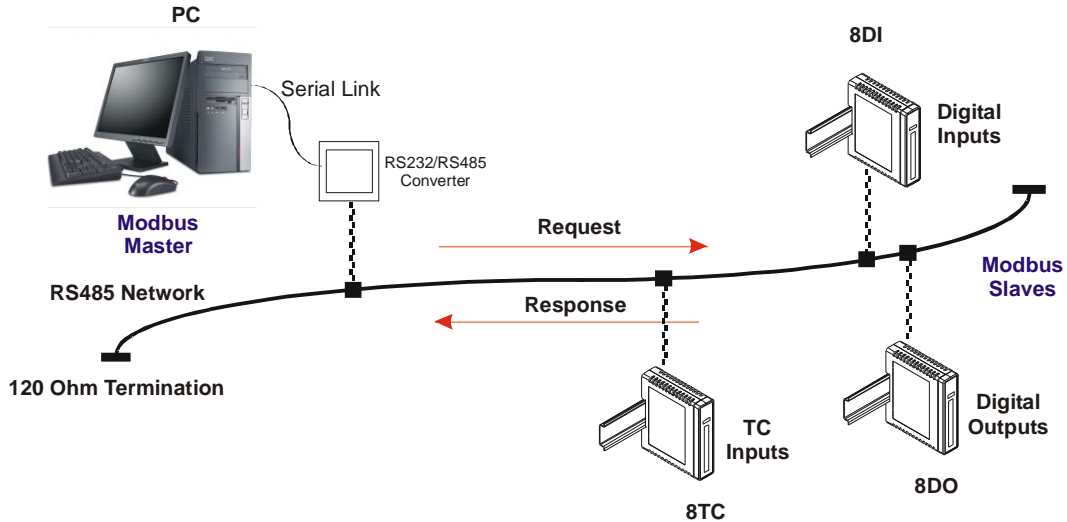

1.2.5 Ethernet.

Procon has developed a Converter which connects to a standard 10/100BaseT Ethernet network. The Converter is given a network IP address and can be accessed by up to 4 PC's at a time. The converter enables PC's and PLC's using the MODBUS/TCP protocol to communicate with the range of PROMUX modules.

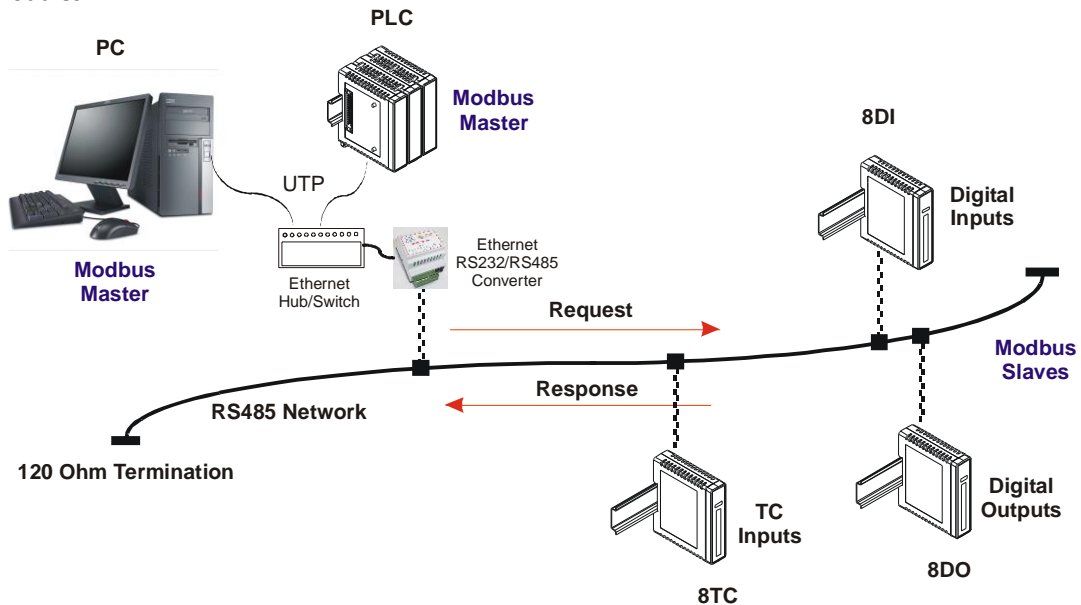

1.2.6 Other Applications.

PROMUX Modules can be connected to a PC or PLC for remote monitoring and control via radio telemetry using third party RF transceivers, Dial-up modems or GPRS modems.

1.3 Module Selection Table

MODEL	MODULE TYPE
I/O MODULES	
PM16DI	16 DIGITAL INPUT MODULE INCLUDING COUNTERS
PM16DI-110	16 DIGITAL INPUT MODULE INCLUDING COUNTERS (110VAC I/P)
PM16DI-220	16 DIGITAL INPUT MODULE INCLUDING COUNTERS (220VAC I/P)
PM16DO	16 DIGITAL OUTPUT MODULE
PM4RO	4 RELAY OUTPUT MODULE
PM8DIO	8 DIGITAL INPUT / 8 DIGITAL OUTPUT MODULE
PM8AI/I	8 ANALOG INPUT 0 - 20mA / 4 - 20mA 12bit or 16 bit
PM8AI/V	8 ANALOG INPUT 0 - 5V / 1 - 5V / 0 - 10V / 2 - 10V 12bit or 16 bit
PM8AI/I ISO	8 ANALOG INPUT 0 - 20mA / 4 - 20mA / ± 20 mA FULLY ISOLATED 12bit or 16 bit
PM8AI/V ISO	8 ANALOG INPUT 0 - 1V / 0 - 10V / ± 1 V / ± 10 V FULLY ISOLATED 12bit or 16 bit
PM8TC	8 THERMOCOUPLE INPUT MODULE INCL. 0 - 50mV & ± 100 mV I/P
PM8TCISO	8 TC INPUT MODULE INCL. 0 - 50mV & ± 100 mV I/P FULLY ISOLATED
PM6RTD	6 RTD INPUT MODULE - PT100, Ni120, PT1000, Ni1000, Ni1000LG & Ohms
PMDAIO	2 RTD I/P, 2 ANALOG INPUT 0 - 20mA / 0 - 10V, 1 ANALOG OUTPUT 0 - 20mA / 0 - 10V, 4 DIGITAL INPUTS, 2 DIGITAL OUTPUTS
PMDAIO2	2 ANALOG INPUT 0 - 20mA / 0 - 10V, 2 ANALOG OUTPUT 0 - 20mA, 4 DIGITAL INPUTS, 4 DIGITAL OUTPUTS
PM8AO	8 ANALOG OUTPUT MODULE 0(4) – 20mA
PM8VO	8 ANALOG OUTPUT MODULE 0(2) – 10V
PM485REP	ISOLATED RS232/RS485 TO RS485 REPEATER
PMFIBRE	RS232/RS485 TO FIBRE OPTICS
MODBUS MASTERS	
PMIOMAP	I/O MAPPER
PMIOMAPTYPE2	I/O MAPPER - ADVANCED

2. PROMUX GENERAL INFORMATION

2.1 Physical Dimensions

The PROMUX enclosure is shown below. The module clips directly onto an industry standard DIN rail. Field wiring is on the front of the module via a separate plug in connector. The module power and RS485 communications wiring is on a separate plug in connector on the underside of the housing.

Allow at least 25mm on front and below the module to accommodate the wiring. Ensure that enough space is kept above and below the module for good ventilation.

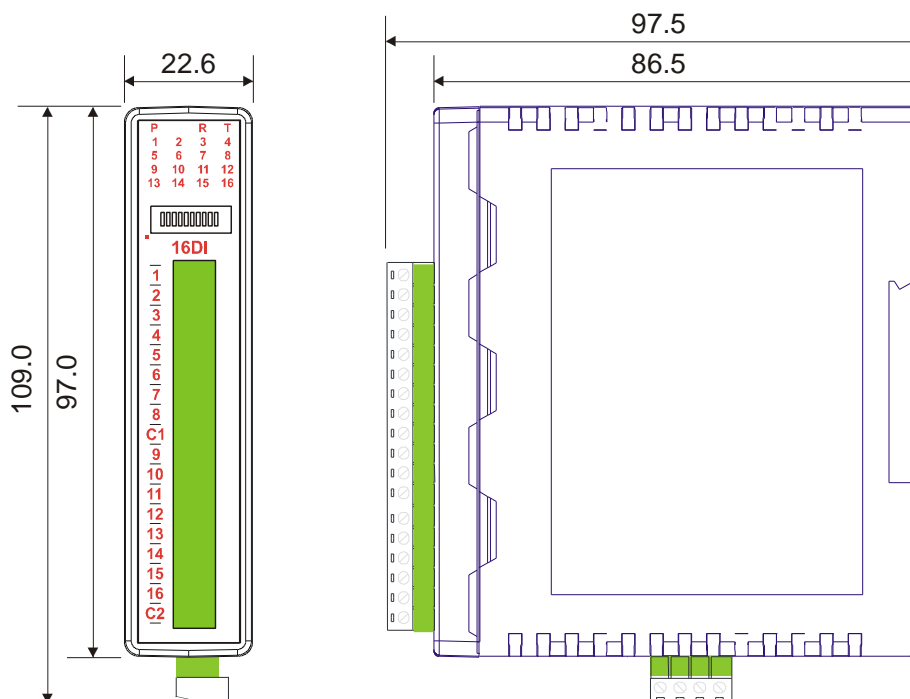

2.2 Grounding/Shielding

In most cases, PROMUX modules will be installed in an enclosure along with other devices which generate electromagnetic radiation. Examples of these devices are relays and contactors, transformers, motor controllers etc. This electromagnetic radiation can induce electrical noise into both power and signal lines, as well as direct radiation into the module causing negative effects on the system. Appropriate grounding, shielding and other protective steps should be taken at the installation stage to prevent these effects. These protective steps include control cabinet grounding, module grounding, cable shield grounding, protective elements for electromagnetic switching devices, correct wiring as well as consideration of cable types and their cross sections.

2.3 Network Termination

Transmission line effects often present a problem on data communication networks. These problems include reflections and signal attenuation.

To eliminate the presence of reflections from the end of the cable, the cable must be terminated at both ends with a resistor across the line equal to its characteristic impedance. Both ends must be terminated since the direction of propagation is bi-directional. In the case of an RS485 twisted pair cable this termination is typically 120 ohms.

2.4 RS485 Network Wiring

RS485 is designed to be used with a single twisted pair cable. One of the restrictions of this system is that the common mode voltages of the nodes on the network should not exceed -7V or +10V. In order to ensure that this condition is met, it is recommended that the 0V connections on the modules be connected together. For modules that are far apart, a second twisted pair should be used as the 0V link.

In certain applications where there are strong possibilities of an earth loop being caused by the 0V link, the link should be tied to the 0V terminal on each module through a 100ohm resistor, to limit the earth loop current.

Where earth loop problems exist, it may be necessary to isolate the RS485 network either using optical fiber or an isolated RS485 repeater such as the PM485REP module.

RS485 Cabling Methodology

Method-1, Single Twisted pair, No shield

In this case, "Earth" is ground and it is inexpensive, easy to install. This kind of cabling is suitable if conduits are used for communication cables, power supply cables are not available and the environment is free from electrical noise. This method is not recommended for industrial applications.

Method-2, Shielded single twisted pair + Earth wire

One pair is used for RS-485 communications and extra wire used specifically for a ground wire.

Method-3, Shielded single twisted pair cable

One pair is used for RS-485 communications and shield is used for return.

Method-4, Shielded twisted pair, 2 pairs

One pair is used for the RS-485 communications and another pair is used for ground.

Method 2 to 4 would reduce noise induced through ground potential differences. This is the preferred option in areas where there is a potential for high electrical noise or if cabling lacks the cleanliness of conduit or wire trays. The drawback of the three conductor option is elevated cable pricing and is slightly more difficult to install. Care must also be taking using this option not to create a ground loop.

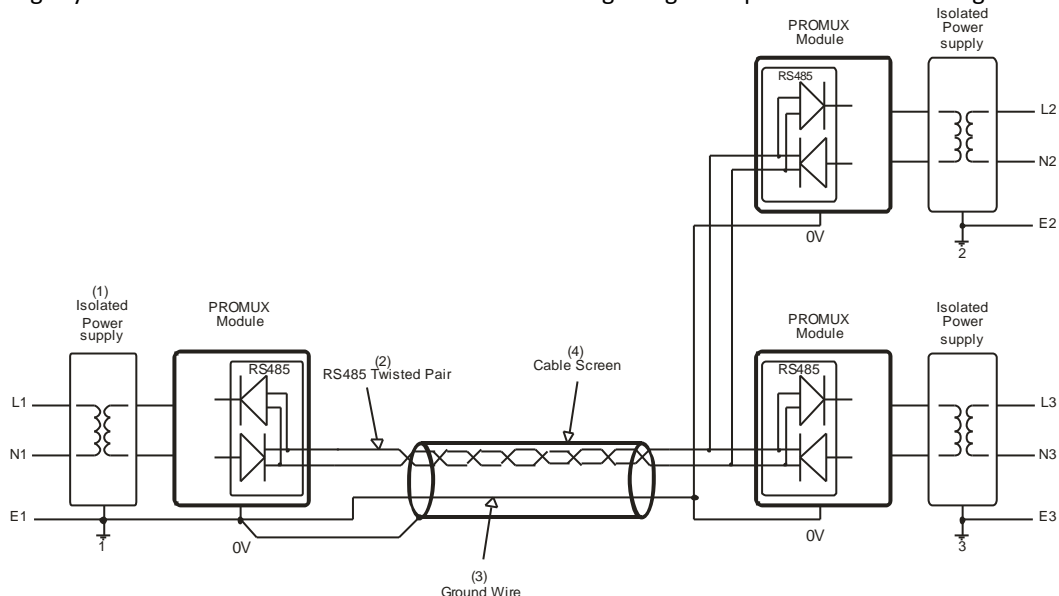

Note: Pin1 at 4 pin connector is 0V terminal in IO modules

Good installation practice for RS485 systems:

1. Use isolated power supplies to ensure that the PROMUX modules are not earthed. Only one module on the network should be earthed. (Module1).
2. Use RS485 twisted cable to prevent electrical noise pickup.
3. Use a ground wire to connect all of the 0V terminals on the modules together. This ensures that all of the modules are at the same potential. The ground wire must be earthed at Module1 only.
4. Use a screened cable to prevent electrical noise pickup. This screen must be earthed at one end only, Module1. If a ground wire is not available then the screen can be used instead. To get the best performance this is not recommended.
5. The RS485 and power supply is wired correctly.
6. Do not carry RS485 and 24V DC power supply in same cables.
7. Use Separate isolated 24V DC for RS485 devices power supply and field inputs.
8. The 0V of the power supply must be earthed.
9. The screen of the RS485 cable must be earthed.
10. The RS485 devices must be at the same earth potential.
11. Use optical isolators in RS485 line to provide protection from low frequency interference from ground loops.
12. Do proper termination and/or shielding to provide isolation from high frequency interference, RFI, and transients.
13. The power supply must have good filters and protection on the 220V/110V side.
14. The RS485 line should have external over voltage protection to protect from high voltage electrical noise being induced into the RS485 cable.
15. Make sure there is a dedicated Instrumentation ground system to be used with RS485 devices.

2.5 RS485 Network Protection

Being used in an industrial environment, the RS485 network could pick up electrical noise from other machinery or even lightning. In this case it is advised that an RS485 network protection device be used at the entry point to the panel where the PROMUX modules are housed.

2.6 Setting the Modbus Node ID

2.6.1 Node ID Table

The following table assists with the setting up of DIP switches for the required NODE ID.

NODE ID		DIP SWITCH SETTINGS					
	SW1	SW2	SW3	SW4	SW5	SW6	SW7
0	OFF	OFF	OFF	OFF	OFF	OFF	OFF
1	ON	OFF	OFF	OFF	OFF	OFF	OFF
2	OFF	ON	OFF	OFF	OFF	OFF	OFF
3	ON	ON	OFF	OFF	OFF	OFF	OFF
4	OFF	OFF	ON	OFF	OFF	OFF	OFF
5	ON	OFF	ON	OFF	OFF	OFF	OFF
6	OFF	ON	ON	OFF	OFF	OFF	OFF
7	ON	ON	ON	OFF	OFF	OFF	OFF
8	OFF	OFF	OFF	ON	OFF	OFF	OFF
9	ON	OFF	OFF	ON	OFF	OFF	OFF
10	OFF	ON	OFF	ON	OFF	OFF	OFF
11	ON	ON	OFF	ON	OFF	OFF	OFF
12	OFF	OFF	ON	ON	OFF	OFF	OFF
13	ON	OFF	ON	ON	OFF	OFF	OFF
14	OFF	ON	ON	ON	OFF	OFF	OFF
15	ON	ON	ON	ON	OFF	OFF	OFF
16	OFF	OFF	OFF	OFF	ON	OFF	OFF
17	ON	OFF	OFF	OFF	ON	OFF	OFF
18	OFF	ON	OFF	OFF	ON	OFF	OFF
19	ON	ON	OFF	OFF	ON	OFF	OFF
20	OFF	OFF	ON	OFF	ON	OFF	OFF
21	ON	OFF	ON	OFF	ON	OFF	OFF
22	OFF	ON	ON	OFF	ON	OFF	OFF
23	ON	ON	ON	OFF	ON	OFF	OFF
24	OFF	OFF	OFF	ON	ON	OFF	OFF
25	ON	OFF	OFF	ON	ON	OFF	OFF
26	OFF	ON	OFF	ON	ON	OFF	OFF
27	ON	ON	OFF	ON	ON	OFF	OFF
28	OFF	OFF	ON	ON	ON	OFF	OFF
29	ON	OFF	ON	ON	ON	OFF	OFF
30	OFF	ON	ON	ON	ON	OFF	OFF
31	ON	ON	ON	ON	ON	OFF	OFF
32	OFF	OFF	OFF	OFF	OFF	ON	OFF
33	ON	OFF	OFF	OFF	OFF	ON	OFF
34	OFF	ON	OFF	OFF	OFF	ON	OFF
35	ON	ON	OFF	OFF	OFF	ON	OFF
36	OFF	OFF	ON	OFF	OFF	ON	OFF
37	ON	OFF	ON	OFF	OFF	ON	OFF
38	OFF	ON	ON	OFF	OFF	ON	OFF
39	ON	ON	ON	OFF	OFF	ON	OFF
40	OFF	OFF	OFF	ON	OFF	ON	OFF
41	ON	OFF	OFF	ON	OFF	ON	OFF

	SW1	SW2	SW3	SW4	SW5	SW6	SW7
42	OFF	ON	OFF	ON	OFF	ON	OFF
43	ON	ON	OFF	ON	OFF	ON	OFF
44	OFF	OFF	ON	ON	OFF	ON	OFF
45	ON	OFF	ON	ON	OFF	ON	OFF
46	OFF	ON	ON	ON	OFF	ON	OFF
47	ON	ON	ON	ON	OFF	ON	OFF
48	OFF	OFF	OFF	OFF	ON	ON	OFF
49	ON	OFF	OFF	OFF	ON	ON	OFF
50	OFF	ON	OFF	OFF	ON	ON	OFF
51	ON	ON	OFF	OFF	ON	ON	OFF
52	OFF	OFF	ON	OFF	ON	ON	OFF
53	ON	OFF	ON	OFF	ON	ON	OFF
54	OFF	ON	ON	OFF	ON	ON	OFF
55	ON	ON	ON	OFF	ON	ON	OFF
56	OFF	OFF	OFF	ON	ON	ON	OFF
57	ON	OFF	OFF	ON	ON	ON	OFF
58	OFF	ON	OFF	ON	ON	ON	OFF
59	ON	ON	OFF	ON	ON	ON	OFF
60	OFF	OFF	ON	ON	ON	ON	OFF
61	ON	OFF	ON	ON	ON	ON	OFF
62	OFF	ON	ON	ON	ON	ON	OFF
63	ON	ON	ON	ON	ON	ON	OFF
64	OFF	OFF	OFF	OFF	OFF	OFF	ON
65	ON	OFF	OFF	OFF	OFF	OFF	ON
66	OFF	ON	OFF	OFF	OFF	OFF	ON
67	ON	ON	OFF	OFF	OFF	OFF	ON
68	OFF	OFF	ON	OFF	OFF	OFF	ON
69	ON	OFF	ON	OFF	OFF	OFF	ON
70	OFF	ON	ON	OFF	OFF	OFF	ON
71	ON	ON	ON	OFF	OFF	OFF	ON
72	OFF	OFF	OFF	ON	OFF	OFF	ON
73	ON	OFF	OFF	ON	OFF	OFF	ON
74	OFF	ON	OFF	ON	OFF	OFF	ON
75	ON	ON	OFF	ON	OFF	OFF	ON
76	OFF	OFF	ON	ON	OFF	OFF	ON
77	ON	OFF	ON	ON	OFF	OFF	ON
78	OFF	ON	ON	ON	OFF	OFF	ON
79	ON	ON	ON	ON	OFF	OFF	ON
80	OFF	OFF	OFF	OFF	ON	OFF	ON
81	ON	OFF	OFF	OFF	ON	OFF	ON
82	OFF	ON	OFF	OFF	ON	OFF	ON
83	ON	ON	OFF	OFF	ON	OFF	ON
84	OFF	OFF	ON	OFF	ON	OFF	ON
85	ON	OFF	ON	OFF	ON	OFF	ON
86	OFF	ON	ON	OFF	ON	OFF	ON
87	ON	ON	ON	OFF	ON	OFF	ON
88	OFF	OFF	OFF	ON	ON	OFF	ON
89	ON	OFF	OFF	ON	ON	OFF	ON
90	OFF	ON	OFF	ON	ON	OFF	ON
NODE ID	DIP SWITCH SETTINGS						

	SW1	SW2	SW3	SW4	SW5	SW6	SW7
91	ON	ON	OFF	ON	ON	OFF	ON
92	OFF	OFF	ON	ON	ON	OFF	ON
93	ON	OFF	ON	ON	ON	OFF	ON
94	OFF	ON	ON	ON	ON	OFF	ON
95	ON	ON	ON	ON	ON	OFF	ON
96	OFF	OFF	OFF	OFF	OFF	ON	ON
97	ON	OFF	OFF	OFF	OFF	ON	ON
98	OFF	ON	OFF	OFF	OFF	ON	ON
99	ON	ON	OFF	OFF	OFF	ON	ON
100	OFF	OFF	ON	OFF	OFF	ON	ON
101	ON	OFF	ON	OFF	OFF	ON	ON
102	OFF	ON	ON	OFF	OFF	ON	ON
103	ON	ON	ON	OFF	OFF	ON	ON
104	OFF	OFF	OFF	ON	OFF	ON	ON
105	ON	OFF	OFF	ON	OFF	ON	ON
106	OFF	ON	OFF	ON	OFF	ON	ON
107	ON	ON	OFF	ON	OFF	ON	ON
108	OFF	OFF	ON	ON	OFF	ON	ON
109	ON	OFF	ON	ON	OFF	ON	ON
110	OFF	ON	ON	ON	OFF	ON	ON
111	ON	ON	ON	ON	OFF	ON	ON
112	OFF	OFF	OFF	OFF	ON	ON	ON
113	ON	OFF	OFF	OFF	ON	ON	ON
114	OFF	ON	OFF	OFF	ON	ON	ON
115	ON	ON	OFF	OFF	ON	ON	ON
116	OFF	OFF	ON	OFF	ON	ON	ON
117	ON	OFF	ON	OFF	ON	ON	ON
118	OFF	ON	ON	OFF	ON	ON	ON
119	ON	ON	ON	OFF	ON	ON	ON
120	OFF	OFF	OFF	ON	ON	ON	ON
121	ON	OFF	OFF	ON	ON	ON	ON
122	OFF	ON	OFF	ON	ON	ON	ON
123	ON	ON	OFF	ON	ON	ON	ON
124	OFF	OFF	ON	ON	ON	ON	ON
125	ON	OFF	ON	ON	ON	ON	ON
126	OFF	ON	ON	ON	ON	ON	ON
127	ON	ON	ON	ON	ON	ON	ON

All modules will respond to a default Node ID of 254.

2.6.2 DIP Switch Status Register.

Each module uses register 30100 to store the status of the DIP switches.

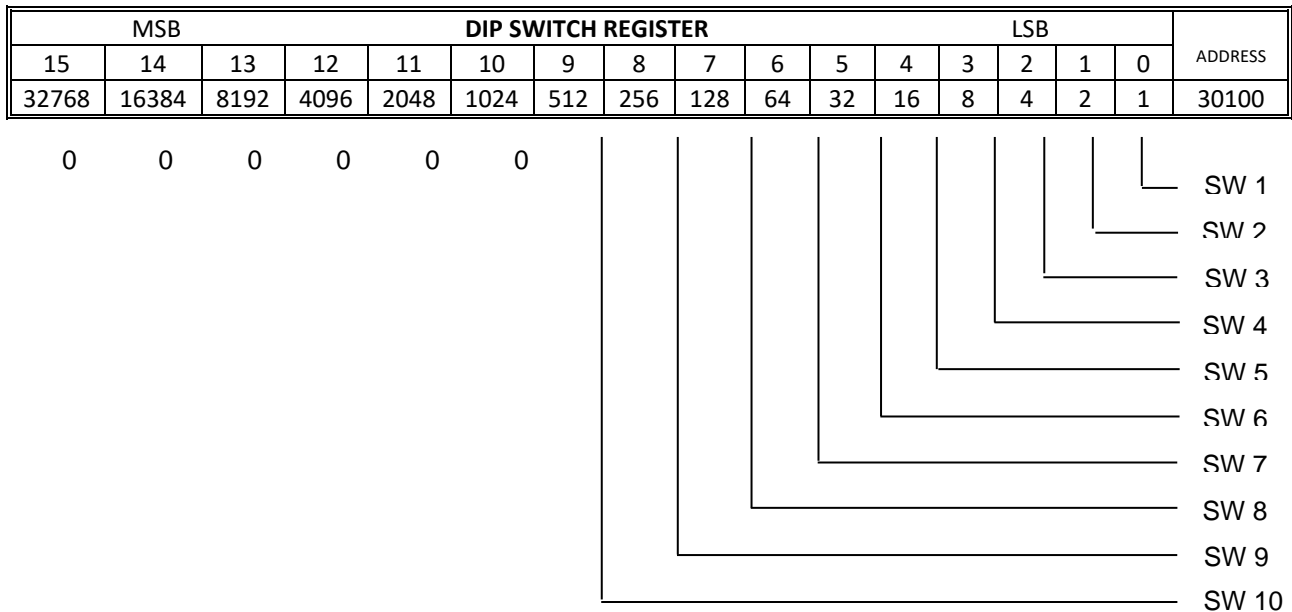

2.7 Communications Settings

The data in the modules is stored in 16 bit registers. These registers are accessed over the network using the MODBUS **RTU** communication protocol.

2.7.1 Communications Settings with DIP Switch 10 Off (Default)

BAUD RATE	9600
DATA BITS	8
PARITY	NONE
STOP BITS	1

2.7.2 Communications Settings with DIP Switch 10 On (Programmed Baud Rate)

BAUD RATE	2400, 4800, 9600, 19200, 38400, 57600, 115200, 187500
DATA BITS	8
PARITY	None, Even, Odd
STOP BITS	1, 2

2.7.3 Communications Settings Registers

40121	Baud Rate	2400	18750	R/W	2400, 4800, 9600, 19200, 38400, 57600, 115200, 187500
40122	Parity	0	2	R/W	0 = none, 1 = even, 2 = odd
40123	Stop Bits	1	2	R/W	1 = 1 stop bit, 2 = 2 stop bits
40124	Reply Delay	0	255	R/W	(x10ms)

2.7.3.1 Baud Rate Register (40121)

The baud rate value is programmed directly into the baud rate register. The only exception is the 115200 baud rate where the value 11520 is used and 187500 baud where the value 18750 is used.

2.7.3.2 Parity Register (40122)

The parity can be set to none by writing a 0 to the parity register, set to even by writing a 1 to the parity Register or set to odd by writing a 2 to the parity register.

2.7.3.3 Stop Bits Register (40123)

The number of stop bits can be set to 1 by writing a 1 to the stop bits register or set to 2 by writing a 2 to the stop bits Register.

2.7.3.4 Reply Delay Register (40124)

The reply delay is a time delay between the Modbus message received to the reply being sent. In some applications where a modem or radio is used in the RS485 network, it may be necessary to add a reply delay due to turn around delays in the equipment.

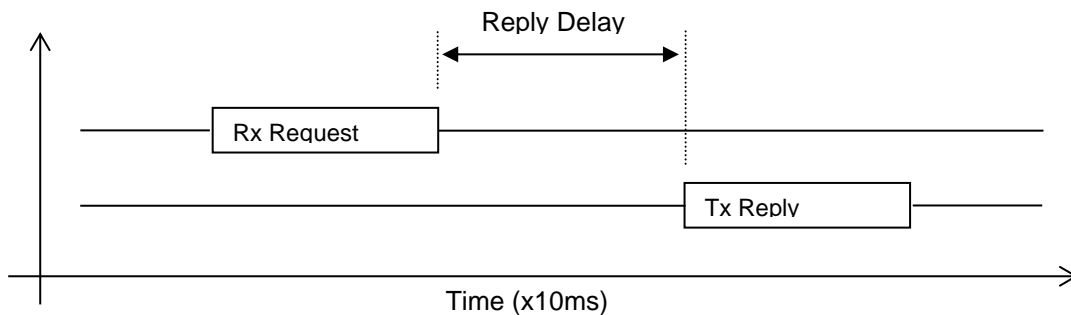

2.7.4 Modbus Register Types

There are 4 types of variables which can be accessed from the module. Each module has one or more of these data variables.

<u>Type</u>	<u>Start Address</u>	<u>Variable</u>	<u>Access</u>
1	00001	Digital Outputs	Read & Write
2	10001	Digital Inputs	Read Only
3	30001	Input registers (Analog)	Read Only
4	40001	Output registers (Analog)	Read & Write

Note: The Modbus message length must be limited to 100 consecutive read or write registers. If more registers are required then a new poll group must be added for the next xxx registers.

2.7.5 Modbus Functions

The PROMUX modules will respond to the following Modbus functions:

- Function 1 – Read I/O status (Digital Inputs and Outputs)
- Function 2 – Read I/O status (Digital Inputs and Outputs)
- Function 3 – Read Register (Analog Inputs and Outputs)
- Function 4 – Read Register (Analog Inputs and Outputs)
- Function 5 – Write Single Digital Output (Digital Outputs)
- Function 6 – Write Single Register (Analog Outputs)
- Function 15 – Write Multiple Digital Outputs (Digital Outputs)
- Function 16 – Write Multiple Registers (Analog Outputs)

3. PROMUX MODULES

3.1 PM16DI - DIGITAL INPUTS WITH COUNTERS

3.1.1 Description

The PM16DI module is a 16 channel digital input module. The inputs are isolated from the logic by bi-directional opto-couplers. The inputs are divided into 2 isolated groups of 8 inputs each. This allows for many configurations in which the input module may be used. One such configuration could be where one group is connected as common positive and the second group connected as common negative.

The counters operate in three modes:

In **mode 0**: All the counters are disabled.

In **mode 1**: The counters are 32 bit counters allowing a count value from 0 to 4294967295. The count value can be cleared by writing a zero to the associated registers or preset to any other value using the same method.

In **mode 2**: The inputs are connected as up/down counters. Input 1 will increment counter 1 whilst input 2 decrements counter1. In the same way, inputs 3&4 operate counter 2, inputs 5&6 operate counter 3 and inputs 7&8 operate counter 4, etc.

When the input filter is configured for > 10ms (Input Filter > 1), the 16 counters are saved in non-volatile memory and the count value will be saved when power fails.

The format of the registers allows the status of the inputs to be read as either single bits or all at once as a single register on the Modbus network.



3.1.2 Technical Specification of PM16DI

Power Supply	Logic Supply Voltage	12 - 24 Vdc
	Logic Supply Current	30mA @ 12V / 17mA @ 24V
Digital Inputs	Input Points	16
	Input Voltage Range	12 - 24 Vdc
	Input Current per input	5mA @ 12Vdc / 11mA @ 24Vdc
	Isolation	1500Vrms between field and logic
Counters (Filter disabled)	Inputs	1 to 16
	Resolution	32 Bits
	Frequency	1KHz (max)
	Pulse Width	500us (min)
Counters (Filter > 1)	Inputs	1 to 16
	Resolution	32 Bits
	Frequency	25Hz (max)
	Pulse Width	20ms (min)
Temperature	Operating Temperature.	-40°C to + 80°C
	Storage Temperature	-40°C to + 85°C
Connectors	Logic Power and Comms.	4 Pin Connector on underside of unit
	Inputs	18 Way screw connector on front

Note: Inputs 1 to 16 are used as both digital inputs and counter inputs.

3.1.3 Status Indicators

- Power:** Flashes to indicate the CPU is running.
- RS485 Rx:** Flashes to indicate the unit has received a valid Modbus message.
- RS485 Tx:** Flashes to indicate the unit has sent a Modbus message.
- Input Status:** "OFF" when the input is off.
"ON" when the input is on.

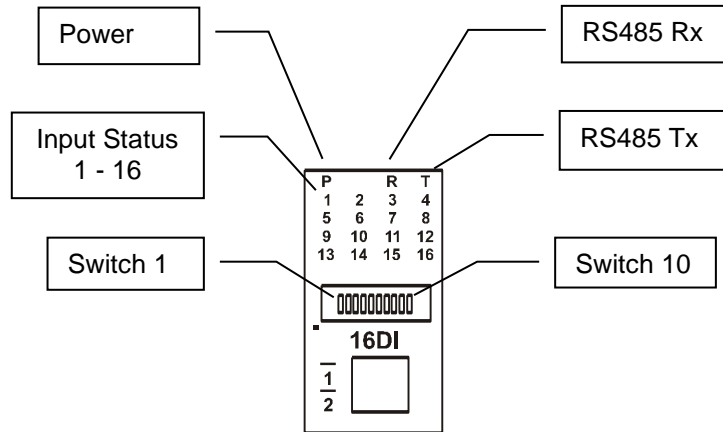

3.1.4 Wiring

The following diagram shows how the digital inputs are connected to potential free switches. The common can be connected to positive or negative as indicated.

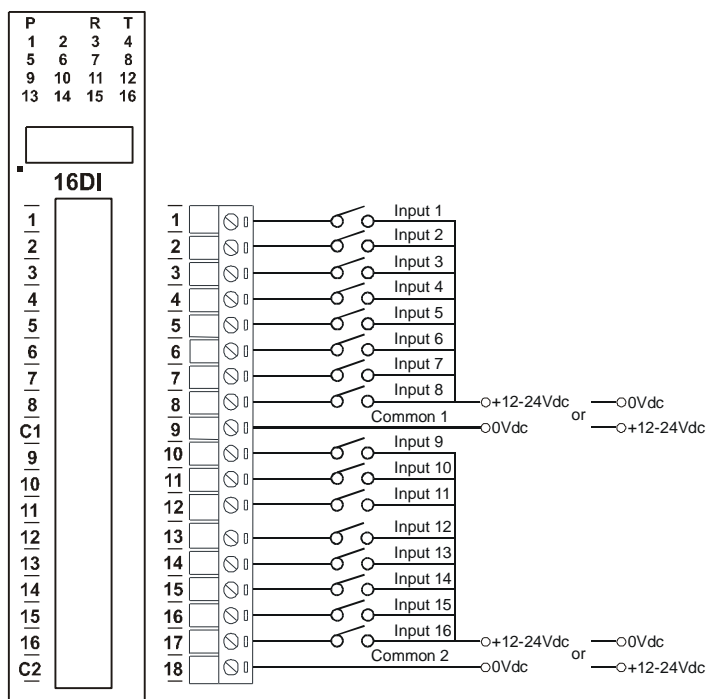

The following diagram shows how the digital inputs are connected a NPN transistor or a PNP transistor.

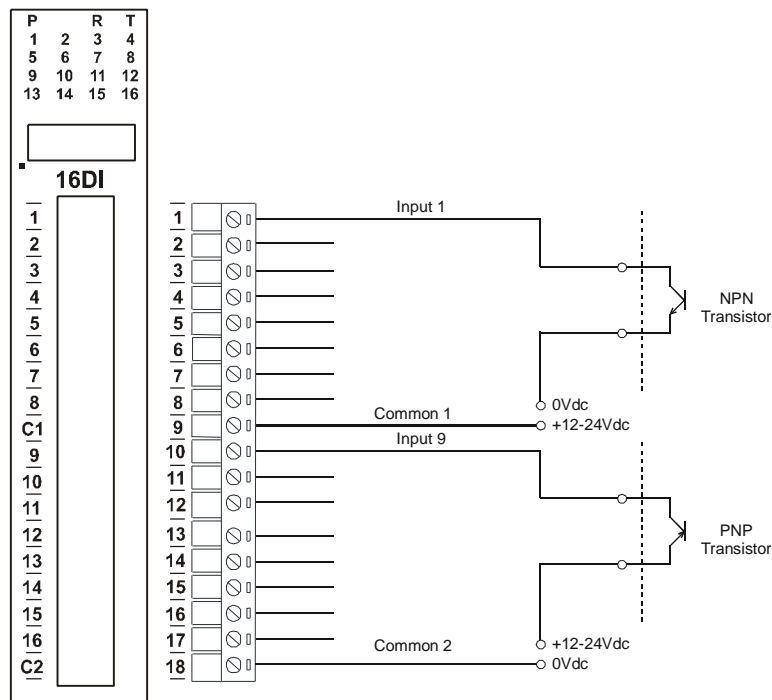

The following diagram shows the wiring for the power and RS485 communications.

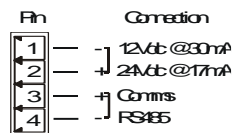

3.1.5 Switch Settings

SWITCH	FUNCTION	DESCRIPTION
1	NODE ID +1	Node ID's from 0 to 127 are set up using switches 1 to 7
2	NODE ID +2	"
3	NODE ID +4	"
4	NODE ID +8	"
5	NODE ID +16	"
6	NODE ID +32	"
7	NODE ID +64	"
8	INVERT	When switched ON the status of the inputs are inverted in the Modbus status register (30002).
9	-	Not Used.
10	BAUD RATE	Selects 9600 (off) or Programmed Baud Rate (on)

3.1.6 PM16DI Data Registers (MODULE TYPE = 100)

Modbus Address	Register Name	Low Limit	High Limit	Access	Description
10001	Digital Input 1	0	1	R	Status of Digital Inputs.
10002	Digital Input 2	0	1	R	
10003	Digital Input 3	0	1	R	
10004	Digital Input 4	0	1	R	
10005	Digital Input 5	0	1	R	
10006	Digital Input 6	0	1	R	
10007	Digital Input 7	0	1	R	
10008	Digital Input 8	0	1	R	
10009	Digital Input 9	0	1	R	
10010	Digital Input 10	0	1	R	
10011	Digital Input 11	0	1	R	
10012	Digital Input 12	0	1	R	
10013	Digital Input 13	0	1	R	
10014	Digital Input 14	0	1	R	
10015	Digital Input 15	0	1	R	
10016	Digital Input 16	0	1	R	
30001	S/W Version / Module Type	N/A	N/A	R	High Byte = Software Version Low Byte = 100
30002	Digital Inputs	N/A	N/A	R	Digital Inputs in 16 bits. 16 - 1.
40003	Counter 1 MSB	0	65535	R/W	Counter MSB and LSB combine to give a 32 bit Counter with range 0 to 4294967295.
40004	Counter 1 LSB	0	65535	R/W	
40005	Counter 2 MSB	0	65535	R/W	"
40006	Counter 2 LSB	0	65535	R/W	"
40007	Counter 3 MSB	0	65535	R/W	"
40008	Counter 3 LSB	0	65535	R/W	"
40009	Counter 4 MSB	0	65535	R/W	"
40010	Counter 4 LSB	0	65535	R/W	"
40011	Counter 5 MSB	0	65535	R/W	"
40012	Counter 5 LSB	0	65535	R/W	"
40013	Counter 6 MSB	0	65535	R/W	"
40014	Counter 6 LSB	0	65535	R/W	"
40015	Counter 7 MSB	0	65535	R/W	"
40016	Counter 7 LSB	0	65535	R/W	"
40017	Counter 8 MSB	0	65535	R/W	"
40018	Counter 8 LSB	0	65535	R/W	"
40019	Counter 9 MSB	0	65535	R/W	"
40020	Counter 9 LSB	0	65535	R/W	"
40021	Counter 10MSB	0	65535	R/W	"
40022	Counter 10LSB	0	65535	R/W	"

Modbus Address	Register Name	Low Limit	High Limit	Access	Description
40023	Counter 11MSB	0	65535	R/W	Counter MSB and LSB combine to give a 32 bit Counter with range 0 to 4294967295.
40024	Counter 11LSB	0	65535	R/W	
40025	Counter 12MSB	0	65535	R/W	"
40026	Counter 12LSB	0	65535	R/W	"
40027	Counter 13MSB	0	65535	R/W	"
40028	Counter 13LSB	0	65535	R/W	"
40029	Counter 14MSB	0	65535	R/W	"
40030	Counter 14LSB	0	65535	R/W	"
40031	Counter 15MSB	0	65535	R/W	"
40032	Counter 15LSB	0	65535	R/W	"
40033	Counter 16MSB	0	65535	R/W	"
40034	Counter 16LSB	0	65535	R/W	"
40035	Counter Capture	0	65535	R/W	Bit1 = 1 to Capture Counter1, Bit2 = 1 to Capture Counter2, etc.
40036	CCounter 1 MSB	0	65535	R/W	Capture Counter Registers. MSB and LSB combine to give a 32 bit Value.
40037	CCounter 1 LSB	0	65535	R/W	
40038	CCounter 2 MSB	0	65535	R/W	Counter with range 0 to 4294967295.
40039	CCounter 2 LSB	0	65535	R/W	
40040	CCounter 3 MSB	0	65535	R/W	"
40041	CCounter 3 LSB	0	65535	R/W	"
40042	CCounter 4 LSB	0	65535	R/W	"
40043	CCounter 4 LSB	0	65535	R/W	"
40044	CCounter 5 MSB	0	65535	R/W	"
40045	CCounter 5 LSB	0	65535	R/W	"
40046	CCounter 6 MSB	0	65535	R/W	"
40047	CCounter 6 LSB	0	65535	R/W	"
40048	CCounter 7 MSB	0	65535	R/W	"
40049	CCounter 7 LSB	0	65535	R/W	"
40050	CCounter 8 MSB	0	65535	R/W	"
40051	CCounter 8 LSB	0	65535	R/W	"
40052	CCounter 9 MSB	0	65535	R/W	"
40053	CCounter 9 LSB	0	65535	R/W	"
40054	CCounter 10MSB	0	65535	R/W	"
40055	CCounter 10LSB	0	65535	R/W	"
40056	CCounter 11MSB	0	65535	R/W	"
40057	CCounter 11LSB	0	65535	R/W	"
40058	CCounter 12MSB	0	65535	R/W	"
40059	CCounter 12LSB	0	65535	R/W	"
40060	CCounter 13MSB	0	65535	R/W	"
40061	CCounter 13LSB	0	65535	R/W	"
40062	CCounter 14MSB	0	65535	R/W	"
40063	CCounter 14LSB	0	65535	R/W	"

Modbus Address	Register Name	Low Limit	High Limit	Access	Description
40064	CCounter 15MSB	0	65535	R/W	"
40065	CCounter 15LSB	0	65535	R/W	"
40066	CCounter 16MSB	0	65535	R/W	"
40067	CCounter 16LSB	0	65535	R/W	"
30100	DIP Switch	0	65535	R	Status of DIP Switch on Front Panel
40101	Counter Mode	0	2	R/W	0=Disable, 1=Up Counting, 2=Up/Down Count
40102	Input Filter	0	65535	R/W	0 = Disable, >0 = Enable. (x10ms)
40103	Capture Zero	0	65535	R/W	0 = Disabled, bit1 = auto zero counter 1.
40121	Baud Rate	2400	18750	R/W	2400, 4800, 9600, 19200, 38400, 57600, 115200, 187500
40122	Parity	0	2	R/W	0 = none, 1 = even, 2 = odd
40123	Stop Bits	1	2	R/W	1 = 1 stop bit, 2 = 2 stop bits
40124	Reply Delay	0	255	R/W	0 = Disable, >0 = Enable. (x10ms)

3.1.6.1 Digital Input Register.

The digital inputs can be read in a single register as follows:

MSB		PM16DI DIGITAL INPUTS													LSB		ADDRESS
15	14	13	12	11	10	9	8	7	6	5	4	3	2	1	0		
32768	16384	8192	4096	2048	1024	512	256	128	64	32	16	8	4	2	1	30002	
16	15	14	13	12	11	10	9	8	7	6	5	4	3	2	1		

Digital Input Number

3.1.6.2 Counter Registers.

The counters are stored as two 16 bit registers. The first register is the High Register and the second register is the Low Register. To get the actual 32 bit count value the registers must be combined as follows:

Counter High Value = Register 40003.

Counter Low Value = Register 40004.

Counter Value = (Counter High Value X 65536) + Counter Low Value.

3.1.6.3 Counter Capture.

To capture a counter a 1 must be written to the corresponding bit position in the Counter Capture Register 40035. For example:

1. Writing 1 to Register 40035 results in Counter 1 value being captured to Counter Capture 1.
2. Writing 2 to Register 40035 results in Counter 2 value being captured to Counter Capture 2.
3. Writing 3 to Register 40035 results in Counter 1 value being captured to Counter Capture 1 and Counter 2 value being captured to Counter Capture 2.

Once the module has Captured the counters, the Counter Capture Register 40035 is cleared to zero. It is possible to read this register to get confirmation that the capture is complete before reading the captured counter values.

3.1.6.4 Counter Auto Zero.

The counter being captured can be auto zeroed. The purpose of this function is to let the module zero the counter so that no counts get lost due to delays from communication latency, etc.

To ensure that a counter is auto zeroed, a 1 must be written to the corresponding bit position in the Capture Zero Register 40103. For example:

Writing 1 to Register 40103 results in Counter 1 value being zeroed when the Counter Capture bit is 1.

The value in the Capture Zero Register 40103 is permanently stored in memory and only has to be configured once.

3.2 PM16DI110 - DIGITAL INPUTS WITH COUNTERS

3.2.1 Description

The PM16DI110 module is a 16 channel digital input module. The inputs are isolated from the logic by bi-directional opto-couplers. The inputs are divided into 2 isolated groups of 8 inputs each. The inputs are designed for 110VAC input voltages.

The counters operate in three modes.

In **mode 0**: All the counters are disabled.

In **mode 1**: The counters are 32 bit counters allowing a count value from 0 to 4294967295. The count value can be cleared by writing a zero to the associated registers or preset to any other value using the same method.

In **mode 2**: The inputs are connected as up/down counters. Input 1 will increment counter 1 whilst input 2 decrements counter1. In the same way, inputs 3&4 operate counter 2, inputs 5&6 operate counter 3 and inputs 7&8 operate counter 4,etc.



Note: The count values are not battery backed-up and will be lost if power is turned off.

The format of the registers allows the status of the inputs to be read as either single bits or all at once as a single register on the Modbus network.

3.2.2 Technical Specification of PM16DI110

Power Supply	Logic Supply Voltage	12 -24 Vdc
	Logic Supply Current	30mA @ 12V / 17mA @ 24V
Digital Inputs	Input Points	16
	Input Voltage Range	100 – 130VAC 50/60Hz
	Input Current per input	2mA
	Isolation	1500Vrms between field and logic
Counters	Inputs	1 to 16
	Resolution	32 Bits
	Frequency	10Hz (max)
	Pulse Width	50ms (min)
Temperature	Operating Temperature.	-40°C to + 80°C
	Storage Temperature	-40°C to + 85°C
Connectors	Logic Power and Comms.	4 Pin Connector on underside of unit
	Inputs	18 Way screw connector on front

Note: Inputs 1 to 16 are used as both digital inputs and counter inputs.

3.2.3 Status Indicators

- Power:** Flashes to indicate the CPU is running.
- RS485 Rx:** Flashes to indicate the unit has received a valid Modbus message.
- RS485 Tx:** Flashes to indicate the unit has sent a Modbus message.
- Input Status:** "OFF" when the input is off.
"ON" when the input is on.

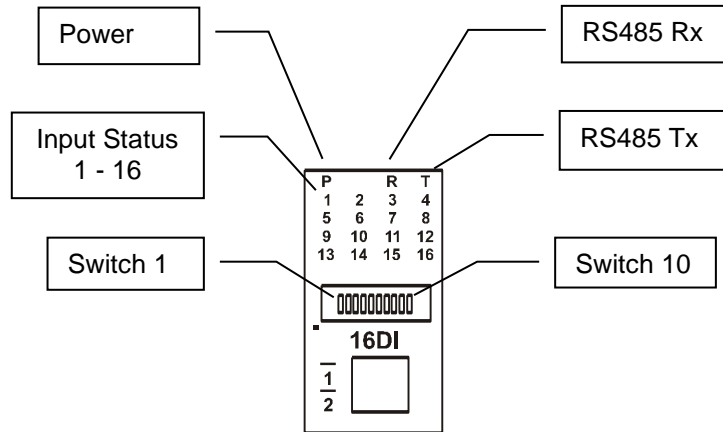

3.2.4 Wiring

The following diagram shows how the digital inputs are connected to potential free switches. The common can be connected to live or neutral as indicated.

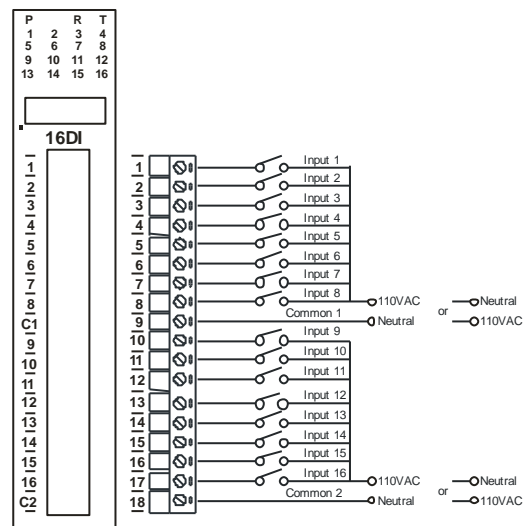

The following diagram shows the wiring for the power and RS485 communications.

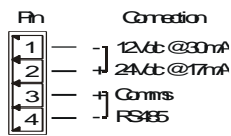

3.2.5 Switch Settings

<u>SWITCH</u>	<u>FUNCTION</u>	<u>DESCRIPTION</u>
1	NODE ID +1	Node ID's from 0 to 127 are set up using switches 1 to 7
2	NODE ID +2	"
3	NODE ID +4	"
4	NODE ID +8	"
5	NODE ID +16	"
6	NODE ID +32	"
7	NODE ID +64	"
8	INVERT	When switched ON the status of the inputs are inverted in the Modbus status register (30002).
9	-	Not Used.
10	BAUD RATE	Selects 9600 (off) or Programmed Baud Rate (on)

3.2.6 PM16DI110 Data Registers (MODULE TYPE = 115)

Modbus Address	Register Name	Low Limit	High Limit	Access	Description
10001	Digital Input 1	0	1	R	Status of Digital Inputs.
10002	Digital Input 2	0	1	R	
10003	Digital Input 3	0	1	R	
10004	Digital Input 4	0	1	R	
10005	Digital Input 5	0	1	R	
10006	Digital Input 6	0	1	R	
10007	Digital Input 7	0	1	R	
10008	Digital Input 8	0	1	R	
10009	Digital Input 9	0	1	R	
10010	Digital Input 10	0	1	R	
10011	Digital Input 11	0	1	R	
10012	Digital Input 12	0	1	R	
10013	Digital Input 13	0	1	R	
10014	Digital Input 14	0	1	R	
10015	Digital Input 15	0	1	R	
10016	Digital Input 16	0	1	R	
30001	S/W Version / Module Type	N/A	N/A	R	High Byte = Software Version Low Byte = 115
30002	Digital Inputs	N/A	N/A	R	Digital Inputs in 16 bits. 16 - 1.
40003	Counter 1 MSB	0	65535	R/W	Counter MSB and LSB combine to give a 32 bit Counter with range 0 to 4294967295.
40004	Counter 1 LSB	0	65535	R/W	
40005	Counter 2 MSB	0	65535	R/W	"
40006	Counter 2 LSB	0	65535	R/W	"
40007	Counter 3 MSB	0	65535	R/W	"
40008	Counter 3 LSB	0	65535	R/W	"
40009	Counter 4 MSB	0	65535	R/W	"
40010	Counter 4 LSB	0	65535	R/W	"
40011	Counter 5 MSB	0	65535	R/W	"
40012	Counter 5 LSB	0	65535	R/W	"
40013	Counter 6 MSB	0	65535	R/W	"
40014	Counter 6 LSB	0	65535	R/W	"
40015	Counter 7 MSB	0	65535	R/W	"
40016	Counter 7 LSB	0	65535	R/W	"
40017	Counter 8 MSB	0	65535	R/W	"
40018	Counter 8 LSB	0	65535	R/W	"
40019	Counter 9 MSB	0	65535	R/W	"
40020	Counter 9 LSB	0	65535	R/W	"
40021	Counter 10MSB	0	65535	R/W	"
40022	Counter 10LSB	0	65535	R/W	"

Modbus Address	Register Name	Low Limit	High Limit	Access	Description
40023	Counter 11MSB	0	65535	R/W	Counter MSB and LSB combine to give a 32 bit
40024	Counter 11LSB	0	65535	R/W	Counter with range 0 to 4294967295.
40025	Counter 12MSB	0	65535	R/W	"
40026	Counter 12LSB	0	65535	R/W	"
40027	Counter 13MSB	0	65535	R/W	"
40028	Counter 13LSB	0	65535	R/W	"
40029	Counter 14MSB	0	65535	R/W	"
40030	Counter 14LSB	0	65535	R/W	"
40031	Counter 15MSB	0	65535	R/W	"
40032	Counter 15LSB	0	65535	R/W	"
40033	Counter 16MSB	0	65535	R/W	"
40034	Counter 16LSB	0	65535	R/W	"
40035	Counter Capture	0	65535	R/W	Bit1 = 1 to Capture Counter1, Bit2 = 1 to Capture Counter2, etc.
40036	CCounter 1 MSB	0	65535	R/W	Capture Counter Registers. MSB and LSB
40037	CCounter 1 LSB	0	65535	R/W	combine to give a 32 bit Value.
40038	CCounter 2 MSB	0	65535	R/W	Counter with range 0 to 4294967295.
40039	CCounter 2 LSB	0	65535	R/W	
40040	CCounter 3 MSB	0	65535	R/W	"
40041	CCounter 3 LSB	0	65535	R/W	"
40042	CCounter 4 LSB	0	65535	R/W	"
40043	CCounter 4 LSB	0	65535	R/W	"
40044	CCounter 5 MSB	0	65535	R/W	"
40045	CCounter 5 LSB	0	65535	R/W	"
40046	CCounter 6 MSB	0	65535	R/W	"
40047	CCounter 6 LSB	0	65535	R/W	"
40048	CCounter 7 MSB	0	65535	R/W	"
40049	CCounter 7 LSB	0	65535	R/W	"
40050	CCounter 8 MSB	0	65535	R/W	"
40051	CCounter 8 LSB	0	65535	R/W	"
40052	CCounter 9 MSB	0	65535	R/W	"
40053	CCounter 9 LSB	0	65535	R/W	"
40054	CCounter 10MSB	0	65535	R/W	"
40055	CCounter 10LSB	0	65535	R/W	"
40056	CCounter 11MSB	0	65535	R/W	"
40057	CCounter 11LSB	0	65535	R/W	"
40058	CCounter 12MSB	0	65535	R/W	"
40059	CCounter 12LSB	0	65535	R/W	"
40060	CCounter 13MSB	0	65535	R/W	"
40061	CCounter 13LSB	0	65535	R/W	"
40062	CCounter 14MSB	0	65535	R/W	"
40063	CCounter 14LSB	0	65535	R/W	"

Modbus Address	Register Name	Low Limit	High Limit	Access	Description
40064	CCounter 15MSB	0	65535	R/W	"
40065	CCounter 15LSB	0	65535	R/W	"
40066	CCounter 16MSB	0	65535	R/W	"
40067	CCounter 16LSB	0	65535	R/W	"
30100	DIP Switch	0	65535	R	Status of DIP Switch on Front Panel
40101	Counter Mode	0	2	R/W	0=Disable, 1=Up Counting, 2=Up/Down Count
40102	Input Filter	0	65535	R/W	0 = Disable, >0 = Enable. (x10ms)
40103	Capture Zero	0	65535	R/W	0 = Disabled, bit1 = auto zero counter 1.
40121	Baud Rate	2400	18750	R/W	2400, 4800, 9600, 19200, 38400, 57600, 115200, 187500
40122	Parity	0	2	R/W	0 = none, 1 = even, 2 = odd
40123	Stop Bits	1	2	R/W	1 = 1 stop bit, 2 = 2 stop bits
40124	Reply Delay	0	255	R/W	0 = Disable, >0 = Enable. (x10ms)

3.2.6.1 Digital Input Register.

The digital inputs can be read in a single register as follows:

MSB		PM16DI DIGITAL INPUTS														LSB		ADDRESS
15	14	13	12	11	10	9	8	7	6	5	4	3	2	1	0			
32768	16384	8192	4096	2048	1024	512	256	128	64	32	16	8	4	2	1	30002		
16	15	14	13	12	11	10	9	8	7	6	5	4	3	2	1			

Digital Input Number

3.2.6.2 Counter Registers.

The counters are stored as two 16 bit registers. The first register is the High Register and the second register is the Low Register. To get the actual 32 bit count value the registers must be combined as follows:

Counter High Value = Register 40003.

Counter Low Value = Register 40004.

Counter Value = (Counter High Value X 65536) + Counter Low Value.

3.2.6.3 Counter Capture.

To capture a counter a 1 must be written to the corresponding bit position in the Counter Capture Register 40035. For example:

1. Writing 1 to Register 40035 results in Counter 1 value being captured to Counter Capture 1.
2. Writing 2 to Register 40035 results in Counter 2 value being captured to Counter Capture 2.
3. Writing 3 to Register 40035 results in Counter 1 value being captured to Counter Capture 1 and Counter 2 value being captured to Counter Capture 2.

Once the module has Captured the counters the Counter Capture Register 40035 is cleared to zero. It is possible to read this register to get confirmation that the capture is complete before reading the captured counter values.

3.2.6.4 Counter Auto Zero.

The counter being captured can be auto zeroed. The purpose of this function is to let the module zero the counter so that no counts get lost due to delays from communication latency, etc.

To ensure that a counter is auto zeroed, a 1 must be written to the corresponding bit position in the Capture Zero Register 40103. For example:

Writing 1 to Register 40103 results in Counter 1 value being zeroed when the Counter Capture bit is 1.

The value in the Capture Zero Register 40103 is permanently stored in memory and only has to be configured once.

3.3 PM16DI220 - DIGITAL INPUTS WITH COUNTERS

3.3.1 Description

The PM16DI220 module is a 16 channel digital input module. The inputs are isolated from the logic by bi-directional opto-couplers. The inputs are divided into 2 isolated groups of 8 inputs each. The inputs are designed for 220VAC input voltages.

The counters operate in three modes.

In **mode 0**: All the counters are disabled.

In **mode 1**: The counters are 32 bit counters allowing a count value from 0 to 4294967295. The count value can be cleared by writing a zero to the associated registers or preset to any other value using the same method.

In **mode 2**: The inputs are connected as up/down counters. Input 1 will increment counter 1 whilst input 2 decrements counter1. In the same way, inputs 3&4 operate counter 2, inputs 5&6 operate counter 3 and inputs 7&8 operate counter 4,etc.



Note: The count values are not battery backed-up and will be lost if power is turned off.

The format of the registers allows the status of the inputs to be read as either single bits or all at once as a single register on the Modbus network.

3.3.2 Technical Specification of PM16DI220

Power Supply	Logic Supply Voltage	12 -24 Vdc
	Logic Supply Current	30mA @ 12V / 17mA @ 24V
Digital Inputs	Input Points	16
	Input Voltage Range	200 – 260VAC
	Input Current per input	1mA
	Isolation	1500Vrms between field and logic
Counters	Inputs	1 to 16
	Resolution	32 Bits
	Frequency	10Hz (max)
	Pulse Width	50ms (min)
Temperature	Operating Temperature.	-40°C to + 80°C
	Storage Temperature	-40°C to + 85°C
Connectors	Logic Power and Comms.	4 Pin Connector on underside of unit
	Inputs	18 Way screw connector on front

Note: Inputs 1 to 16 are used as both digital inputs and counter inputs.

3.3.3 Status Indicators

- Power:** Flashes to indicate the CPU is running.
- RS485 Rx:** Flashes to indicate the unit has received a valid Modbus message.
- RS485 Tx:** Flashes to indicate the unit has sent a Modbus message.
- Input Status:** "OFF" when the input is off.
"ON" when the input is on.

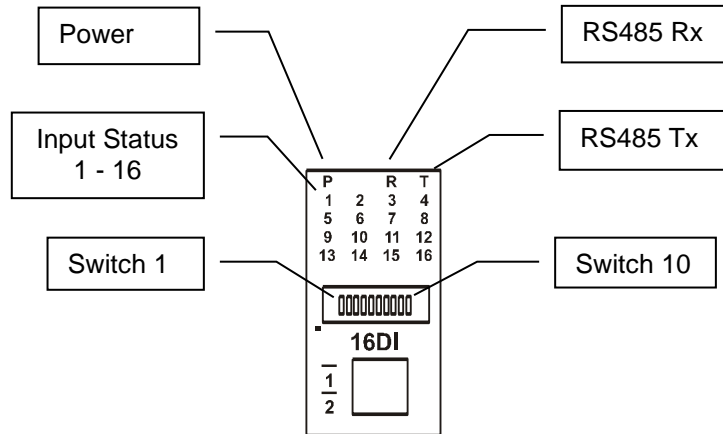

3.3.4 Wiring

The following diagram shows how the digital inputs are connected to potential free switches. The common can be connected to live or neutral as indicated.

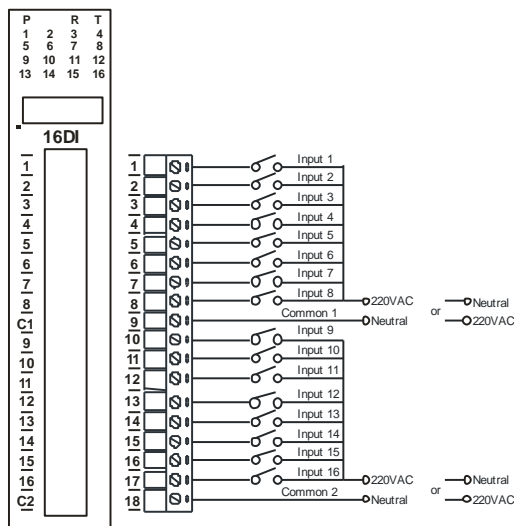

The following diagram shows the wiring for the power and RS485 communications.

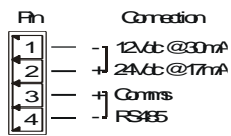

3.3.5 Switch Settings

<u>SWITCH</u>	<u>FUNCTION</u>	<u>DESCRIPTION</u>
1	NODE ID +1	Node ID's from 0 to 127 are set up using switches 1 to 7
2	NODE ID +2	"
3	NODE ID +4	"
4	NODE ID +8	"
5	NODE ID +16	"
6	NODE ID +32	"
7	NODE ID +64	"
8	INVERT	When switched ON the status of the inputs are inverted in the Modbus status register (30002).
9	-	Not Used.
10	BAUD RATE	Selects 9600 (off) or Programmed Baud Rate (on)

3.3.6 PM16DI220 Data Registers (MODULE TYPE = 116)

Modbus Address	Register Name	Low Limit	High Limit	Access	Description
10001	Digital Input 1	0	1	R	Status of Digital Inputs.
10002	Digital Input 2	0	1	R	
10003	Digital Input 3	0	1	R	
10004	Digital Input 4	0	1	R	
10005	Digital Input 5	0	1	R	
10006	Digital Input 6	0	1	R	
10007	Digital Input 7	0	1	R	
10008	Digital Input 8	0	1	R	
10009	Digital Input 9	0	1	R	
10010	Digital Input 10	0	1	R	
10011	Digital Input 11	0	1	R	
10012	Digital Input 12	0	1	R	
10013	Digital Input 13	0	1	R	
10014	Digital Input 14	0	1	R	
10015	Digital Input 15	0	1	R	
10016	Digital Input 16	0	1	R	
30001	S/W Version / Module Type	N/A	N/A	R	High Byte = Software Version Low Byte = 116
30002	Digital Inputs	N/A	N/A	R	Digital Inputs in 16 bits. 16 - 1.
40003	Counter 1 MSB	0	65535	R/W	Counter MSB and LSB combine to give a 32 bit Counter with range 0 to 4294967295.
40004	Counter 1 LSB	0	65535	R/W	
40005	Counter 2 MSB	0	65535	R/W	"
40006	Counter 2 LSB	0	65535	R/W	"
40007	Counter 3 MSB	0	65535	R/W	"
40008	Counter 3 LSB	0	65535	R/W	"
40009	Counter 4 MSB	0	65535	R/W	"
40010	Counter 4 LSB	0	65535	R/W	"
40011	Counter 5 MSB	0	65535	R/W	"
40012	Counter 5 LSB	0	65535	R/W	"
40013	Counter 6 MSB	0	65535	R/W	"
40014	Counter 6 LSB	0	65535	R/W	"
40015	Counter 7 MSB	0	65535	R/W	"
40016	Counter 7 LSB	0	65535	R/W	"
40017	Counter 8 MSB	0	65535	R/W	"
40018	Counter 8 LSB	0	65535	R/W	"
40019	Counter 9 MSB	0	65535	R/W	"
40020	Counter 9 LSB	0	65535	R/W	"
40021	Counter 10MSB	0	65535	R/W	"
40022	Counter 10LSB	0	65535	R/W	"

Modbus Address	Register Name	Low Limit	High Limit	Access	Description
40023	Counter 11MSB	0	65535	R/W	Counter MSB and LSB combine to give a 32 bit
40024	Counter 11LSB	0	65535	R/W	Counter with range 0 to 4294967295.
40025	Counter 12MSB	0	65535	R/W	"
40026	Counter 12LSB	0	65535	R/W	"
40027	Counter 13MSB	0	65535	R/W	"
40028	Counter 13LSB	0	65535	R/W	"
40029	Counter 14MSB	0	65535	R/W	"
40030	Counter 14LSB	0	65535	R/W	"
40031	Counter 15MSB	0	65535	R/W	"
40032	Counter 15LSB	0	65535	R/W	"
40033	Counter 16MSB	0	65535	R/W	"
40034	Counter 16LSB	0	65535	R/W	"
40035	Counter Capture	0	65535	R/W	Bit1 = 1 to Capture Counter1, Bit2 = 1 to Capture Counter2, etc.
40036	CCounter 1 MSB	0	65535	R/W	Capture Counter Registers. MSB and LSB
40037	CCounter 1 LSB	0	65535	R/W	combine to give a 32 bit Value.
40038	CCounter 2 MSB	0	65535	R/W	Counter with range 0 to 4294967295.
40039	CCounter 2 LSB	0	65535	R/W	
40040	CCounter 3 MSB	0	65535	R/W	"
40041	CCounter 3 LSB	0	65535	R/W	"
40042	CCounter 4 LSB	0	65535	R/W	"
40043	CCounter 4 LSB	0	65535	R/W	"
40044	CCounter 5 MSB	0	65535	R/W	"
40045	CCounter 5 LSB	0	65535	R/W	"
40046	CCounter 6 MSB	0	65535	R/W	"
40047	CCounter 6 LSB	0	65535	R/W	"
40048	CCounter 7 MSB	0	65535	R/W	"
40049	CCounter 7 LSB	0	65535	R/W	"
40050	CCounter 8 MSB	0	65535	R/W	"
40051	CCounter 8 LSB	0	65535	R/W	"
40052	CCounter 9 MSB	0	65535	R/W	"
40053	CCounter 9 LSB	0	65535	R/W	"
40054	CCounter 10MSB	0	65535	R/W	"
40055	CCounter 10LSB	0	65535	R/W	"
40056	CCounter 11MSB	0	65535	R/W	"
40057	CCounter 11LSB	0	65535	R/W	"
40058	CCounter 12MSB	0	65535	R/W	"
40059	CCounter 12LSB	0	65535	R/W	"
40060	CCounter 13MSB	0	65535	R/W	"
40061	CCounter 13LSB	0	65535	R/W	"
40062	CCounter 14MSB	0	65535	R/W	"
40063	CCounter 14LSB	0	65535	R/W	"

Modbus Address	Register Name	Low Limit	High Limit	Access	Description
40064	CCounter 15MSB	0	65535	R/W	"
40065	CCounter 15LSB	0	65535	R/W	"
40066	CCounter 16MSB	0	65535	R/W	"
40067	CCounter 16LSB	0	65535	R/W	"
30100	DIP Switch	0	65535	R	Status of DIP Switch on Front Panel
40101	Counter Mode	0	2	R/W	0=Disable, 1=Up Counting, 2=Up/Down Count
40102	Input Filter	0	65535	R/W	0 = Disable, >0 = Enable. (x10ms)
40103	Capture Zero	0	65535	R/W	0 = Disabled, bit1 = auto zero counter 1.
40121	Baud Rate	2400	18750	R/W	2400, 4800, 9600, 19200, 38400, 57600, 115200, 187500
40122	Parity	0	2	R/W	0 = none, 1 = even, 2 = odd
40123	Stop Bits	1	2	R/W	1 = 1 stop bit, 2 = 2 stop bits
40124	Reply Delay	0	255	R/W	0 = Disable, >0 = Enable. (x10ms)

3.3.6.1 Digital Input Register.

The digital inputs can be read in a single register as follows:

MSB		PM16DI DIGITAL INPUTS														LSB		ADDRESS
15	14	13	12	11	10	9	8	7	6	5	4	3	2	1	0			
32768	16384	8192	4096	2048	1024	512	256	128	64	32	16	8	4	2	1	30002		
16	15	14	13	12	11	10	9	8	7	6	5	4	3	2	1			

Digital Input Number

3.3.6.2 Counter Registers.

The counters are stored as two 16 bit registers. The first register is the High Register and the second register is the Low Register. To get the actual 32 bit count value the registers must be combined as follows:

Counter High Value = Register 40003.

Counter Low Value = Register 40004.

Counter Value = (Counter High Value X 65536) + Counter Low Value.

3.3.6.3 Counter Capture.

To capture a counter a 1 must be written to the corresponding bit position in the Counter Capture Register 40035. For example:

1. Writing 1 to Register 40035 results in Counter 1 value being captured to Counter Capture 1.
2. Writing 2 to Register 40035 results in Counter 2 value being captured to Counter Capture 2.
3. Writing 3 to Register 40035 results in Counter 1 value being captured to Counter Capture 1 and Counter 2 value being captured to Counter Capture 2.

Once the module has Captured the counters the Counter Capture Register 40035 is cleared to zero. It is possible to read this register to get confirmation that the capture is complete before reading the captured counter values.

3.3.6.4 Counter Auto Zero.

The counter being captured can be auto zeroed. The purpose of this function is to let the module zero the counter so that no counts get lost due to delays from communication latency, etc.

To ensure that a counter is auto zeroed, a 1 must be written to the corresponding bit position in the Capture Zero Register 40103. For example:

Writing 1 to Register 40103 results in Counter 1 value being zeroed when the Counter Capture bit is 1.

The value in the Capture Zero Register 40103 is permanently stored in memory and only has to be configured once.

3.4 PM16DO - DIGITAL OUTPUTS

3.4.1 Description

This module has 16 open collector (NPN) digital outputs. The outputs may be used to drive lamps or external relays when more drive capability is required. The outputs are isolated from the logic and they share a common negative terminal.

The module may be used as either a slave or master on the Modbus network. When used with a PC or PLC the module will be configured as a slave. When used with a PM16DI module in a point-to-point configuration, the DIP switch 9 must be turned on to set the module up as a master. In this mode the PM16DO module will automatically read the information from the PM16DI module and write the input status to the outputs.

When used as a slave module, the outputs are written to by the Modbus master device such as a PC or PLC. Each output can be individually switched on or off, or all outputs can be set up at the same time by writing a single number to the output register which represents the status of all outputs.

An output watchdog timer can be configured to switch off all the outputs if there has been no communications with the module for up to 255 seconds. A value of 0 seconds will disable this timer and the outputs will remain in the last programmed state.



3.4.2 Technical Specification of PM16DO

Power Supply	Logic Supply Voltage	12 -24 Vdc
	Logic Supply Current	23mA @ 12V / 14mA @ 24V
	Field Supply Voltage	12 -24 Vdc
	Field Supply Current	6mA @ 12V / 6mA @ 24V
Digital Outputs	Output Points	16
	Maximum Voltage	36 Vdc
	Maximum Current	100 mA per output
	Vceon	1.1V Max.
	Isolation	1500Vrms between field and logic
Temperature	Operating Temperature.	-40°C to + 80°C
	Storage Temperature	-40°C to + 85°C
Connectors	Logic Power and Comms.	4 Pin Connector on underside of unit
	Outputs	18 Way screw connector on front

3.4.3 Status Indicators

Power: Flashes to indicate the CPU is running.

RS485 Rx: Flashes to indicate the unit has received a valid Modbus message.

RS485 Tx: Flashes to indicate the unit has sent a Modbus message.

Output Status: "OFF" when the output is off.
"ON" when the output is on.

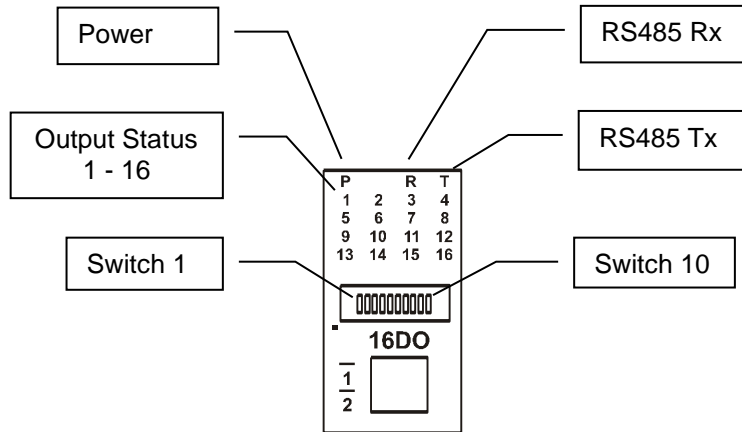

3.4.4 Wiring

The following diagram shows how the digital outputs are connected to the coil of a relay. The coil is connected to positive and switched to negative.

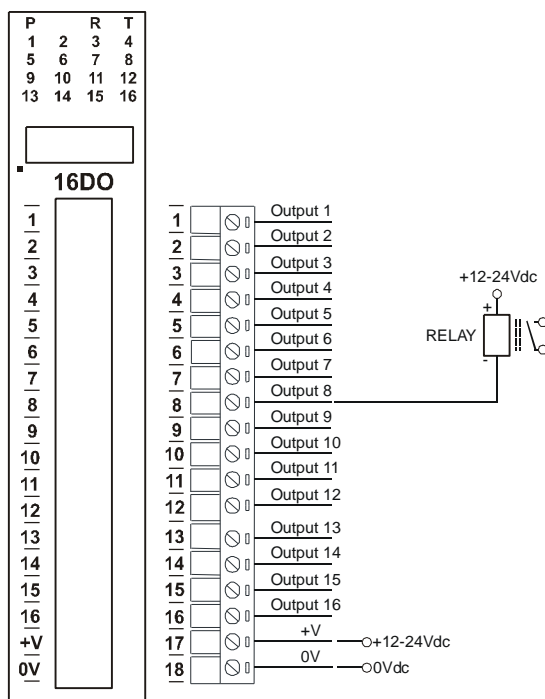

The following diagram shows the wiring for the power and RS485 communications.

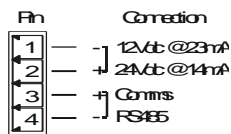

3.4.5 Switch Setting

<u>SWITCH</u>	<u>FUNCTION</u>	<u>DESCRIPTION</u>
1	NODE ID +1	Node ID's from 0 to 127 are set up using switches 1 to 7
2	NODE ID +2	"
3	NODE ID +4	"
4	NODE ID +8	"
5	NODE ID +16	"
6	NODE ID +32	"
7	NODE ID +64	"
8	-	Not Used.
9	MODE	Selects Master or Slave Mode. Master mode is used when the module is connected to a single digital input module. Slave mode is used when the module is to be polled either by the I/O Mapper or by a PC.
10	BAUD RATE	Selects 9600 (off) or Programmed Baud Rate (on)

3.4.6 PM16DO Data Registers (MODULE TYPE = 101)

Modbus Address	Register Name	Low Limit	High Limit	Access	Comments
00001	Digital Output 1	0	1	R/W	Status of Digital Outputs.
00002	Digital Output 2	0	1	R/W	"
00003	Digital Output 3	0	1	R/W	"
00004	Digital Output 4	0	1	R/W	"
00005	Digital Output 5	0	1	R/W	"
00006	Digital Output 6	0	1	R/W	"
00007	Digital Output 7	0	1	R/W	"
00008	Digital Output 8	0	1	R/W	"
00009	Digital Output 9	0	1	R/W	"
00010	Digital Output 10	0	1	R/W	"
00011	Digital Output 11	0	1	R/W	"
00012	Digital Output 12	0	1	R/W	"
00013	Digital Output 13	0	1	R/W	"
00014	Digital Output 14	0	1	R/W	"
00015	Digital Output 15	0	1	R/W	"
00016	Digital Output 16	0	1	R/W	"
30001	S/W Version / Module Type	N/A	N/A	R	High Byte = Software Version Low Byte = 101
40002	Digital Outputs	N/A	N/A	R/W	Digital Outputs in bits. 16(msb) – 1(lsb).
30100	DIP Switch	0	65535	R	Status of DIP Switch on Front Panel
40101	Watchdog Timer	0	255	R/W	Timer in seconds. 0 = disabled. 1 - 255 = enabled.
40102	Master Timeout	0	65535	R/W	Modbus Master Timeout (X10ms)
40103	Master Poll Rate	0	65535	R/W	Modbus Master Poll Rate (X10ms)
40121	Baud Rate	2400	18750	R/W	2400, 4800, 9600, 19200, 38400, 57600, 115200, 187500
40122	Parity	0	2	R/W	0 = none, 1 = even, 2 = odd
40123	Stop Bits	1	2	R/W	1 = 1 stop bit, 2 = 2 stop bits
40124	Reply Delay	0	255	R/W	0 = Disable, >0 = Enable. (x10ms)

3.4.6.1 Digital Output Register.

The digital outputs can be read/written in a single register as follows:

PM16DO DIGITAL OUTPUTS															ADDRESS	
MSB							LSB									
15	14	13	12	11	10	9	8	7	6	5	4	3	2	1	0	
32768	16384	8192	4096	2048	1024	512	256	128	64	32	16	8	4	2	1	40002
16	15	14	13	12	11	10	9	8	7	6	5	4	3	2	1	

Digital Output

3.4.6.2 Output Watchdog Timer.

The watchdog timer is used to switch off all of the outputs in the event of a communications failure. When set to zero (register 40101) the watchdog timer is disabled.

3.4.7 Modbus Master Setup.

The module is configured as a Modbus master when switch 9 is on. The PM16DO reads digital inputs from a PM16DI module and writes the information to the outputs. The two modules must have the same network ID and these must be the only modules on the network.

3.4.7.1 Modbus Master Poll Rate.

The rate at which the PM16DO polls the PM16DI is configured using this register (40103). In some applications where a modem or radio is used in the RS485 network, it may be necessary to slow down the polling of the PM16DI due to turn around delays in the equipment.

3.4.7.2 Modbus Master Timeout.

The PM16DO polls the PM16DI to get the input data. If there is a problem and the message is corrupted or gets lost, then the PM16DO communications routine will timeout and try again. This parameter should be set to a larger value than the poll rate value.

3.6 PM16DOP - DIGITAL OUTPUTS

3.6.1 Description

The PE16DOP module is a 16 channel digital output module. The 16 digital outputs are open drain MOSFET (P-TYPE) implemented as a high side switch. The outputs can be used to switch resistive, capacitive and inductive loads. The outputs may be used to drive lamps or external relays when more drive capability is required. The outputs are isolated from the logic and they share a common positive terminal.

The module may be used as either a slave or master on the Modbus network. When used with a PC or PLC the module will be configured as a slave. When used with a PM16DI module in a point-to-point configuration, the DIP switch 9 must be turned on to set the module up as a master. In this mode the PM16DOP module will automatically read the information from the PM16DI module and write the input status to the outputs.

When used as a slave module, the outputs are written to by the Modbus master device such as a PC or PLC. Each output can be individually switched on or off, or all outputs can be set up at the same time by writing a single number to the output register which represents the status of all outputs.

An output watchdog timer can be configured to switch off all the outputs if there has been no communications with the module for up to 255 seconds. A value of 0 seconds will disable this timer and the outputs will remain in the last programmed state.



3.6.2 Technical Specification of PM16DOP

Power Supply	Logic Supply Voltage	12 -24 Vdc
	Logic Supply Current	23mA @ 12V / 14mA @ 24V
	Field Supply Voltage	12 -24 Vdc
	Field Supply Current	6mA @ 12V / 6mA @ 24V
Digital Outputs	Output Points	16
	Maximum Voltage	24 Vdc
	Maximum Current	1A per output
	On-state resistance	0.14 ohms
	Isolation	1500Vrms between field and logic
Temperature	Operating Temperature.	-40°C to + 80°C
	Storage Temperature	-40°C to + 85°C
Connectors	Logic Power and Comms.	4 Pin Connector on underside of unit
	Outputs	18 Way screw connector on front

3.6.3 Status Indicators

Power: Flashes to indicate the CPU is running.

RS485 Rx: Flashes to indicate the unit has received a valid Modbus message.

RS485 Tx: Flashes to indicate the unit has sent a Modbus message.

Output Status: "OFF" when the output is off.
"ON" when the output is on.

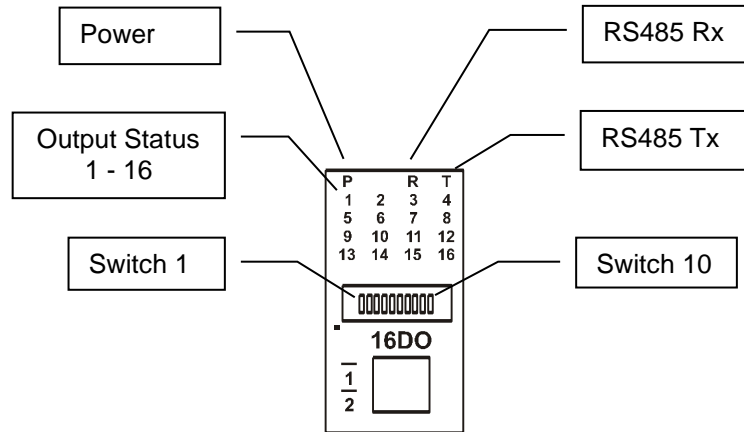

3.6.4 Wiring

The following diagram shows how the digital outputs are connected to the coil of a relay. The coil is connected to positive and switched to negative.

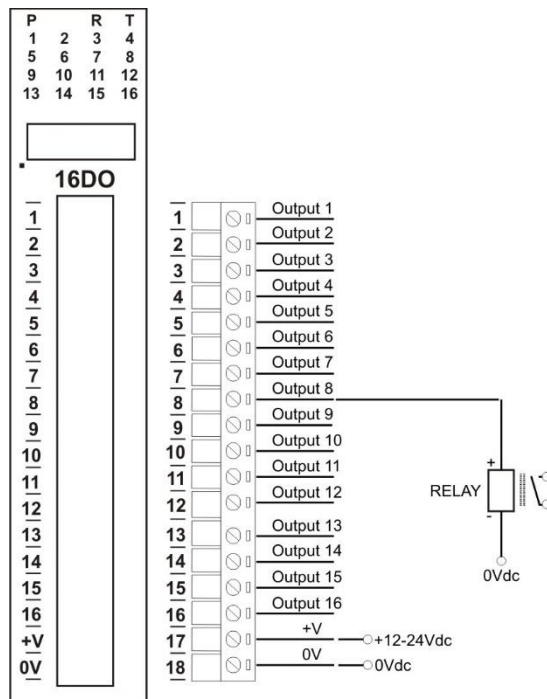

The following diagram shows the wiring for the power and RS485 communications.

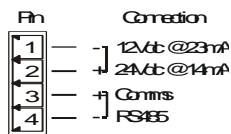

3.6.5 Switch Setting

<u>SWITCH</u>	<u>FUNCTION</u>	<u>DESCRIPTION</u>
1	NODE ID +1	Node ID's from 0 to 127 are set up using switches 1 to 7
2	NODE ID +2	"
3	NODE ID +4	"
4	NODE ID +8	"
5	NODE ID +16	"
6	NODE ID +32	"
7	NODE ID +64	"
8	-	Not Used.
9	MODE	Selects Master or Slave Mode. Master mode is used when the module is connected to a single digital input module. Slave mode is used when the module is to be polled either by the I/O Mapper or by a PC.
10	BAUD RATE	Selects 9600 (off) or Programmed Baud Rate (on)

3.6.6 PM16DOP Data Registers (MODULE TYPE = 101)

Modbus Address	Register Name	Low Limit	High Limit	Access	Comments
00001	Digital Output 1	0	1	R/W	Status of Digital Outputs.
00002	Digital Output 2	0	1	R/W	"
00003	Digital Output 3	0	1	R/W	"
00004	Digital Output 4	0	1	R/W	"
00005	Digital Output 5	0	1	R/W	"
00006	Digital Output 6	0	1	R/W	"
00007	Digital Output 7	0	1	R/W	"
00008	Digital Output 8	0	1	R/W	"
00009	Digital Output 9	0	1	R/W	"
00010	Digital Output 10	0	1	R/W	"
00011	Digital Output 11	0	1	R/W	"
00012	Digital Output 12	0	1	R/W	"
00013	Digital Output 13	0	1	R/W	"
00014	Digital Output 14	0	1	R/W	"
00015	Digital Output 15	0	1	R/W	"
00016	Digital Output 16	0	1	R/W	"
30001	S/W Version / Module Type	N/A	N/A	R	High Byte = Software Version Low Byte = 101
40002	Digital Outputs	N/A	N/A	R/W	Digital Outputs in bits. 16(msb) – 1(lsb).
30100	DIP Switch	0	65535	R	Status of DIP Switch on Front Panel
40101	Watchdog Timer	0	255	R/W	Timer in seconds. 0 = disabled. 1 - 255 = enabled.
40102	Master Timeout	0	65535	R/W	Modbus Master Timeout (X10ms)
40103	Master Poll Rate	0	65535	R/W	Modbus Master Poll Rate (X10ms)
40121	Baud Rate	2400	18750	R/W	2400, 4800, 9600, 19200, 38400, 57600, 115200, 187500
40122	Parity	0	2	R/W	0 = none, 1 = even, 2 = odd
40123	Stop Bits	1	2	R/W	1 = 1 stop bit, 2 = 2 stop bits
40124	Reply Delay	0	255	R/W	0 = Disable, >0 = Enable. (x10ms)

3.6.6.1 Digital Output Register.

The digital outputs can be read/written in a single register as follows:

PM16DOP DIGITAL OUTPUTS															ADDRESS	
MSB							LSB									
15	14	13	12	11	10	9	8	7	6	5	4	3	2	1	0	
32768	16384	8192	4096	2048	1024	512	256	128	64	32	16	8	4	2	1	40002
16	15	14	13	12	11	10	9	8	7	6	5	4	3	2	1	

Digital Output

3.6.6.2 Output Watchdog Timer.

The watchdog timer is used to switch off all of the outputs in the event of a communications failure. When set to zero (register 40101) the watchdog timer is disabled.

3.6.7 Modbus Master Setup.

The module is configured as a Modbus master when switch 9 is on. The PM16DOP reads digital inputs from a PM16DOP module and writes the information to the outputs. The two modules must have the same network ID and these must be the only modules on the network.

3.6.7.1 Modbus Master Poll Rate.

The rate at which the PM16DOP polls the PM16DI is configured using this register (40103). In some applications where a modem or radio is used in the RS485 network, it may be necessary to slow down the polling of the PM16DI due to turn around delays in the equipment.

3.6.7.2 Modbus Master Timeout.

The PM16DOP polls the PM16DI to get the input data. If there is a problem and the message is corrupted or gets lost, then the PM16DOP communications routine will timeout and try again. This parameter should be set to a larger value than the poll rate value.

3.7 PM4RO - RELAY OUTPUTS

3.7.1 Description

The MM4RO module has 4 normally open/ normally closed relay outputs. These modules may be used when a higher drive capability is required, or when isolation between outputs are required.

The module may be used as either a slave or master on the Modbus network. When used with a PC or PLC the module will be configured as a slave. When used with a PM16DI module in a point-to-point configuration, the DIP switch 9 must be turned on to set the module up as a master. In this mode the PM4RO module will automatically read the information from the PM16DI module and write the input status to the outputs.

When used as a slave module, the outputs are written to by the Modbus master device such as a PC or PLC. Each output can be individually switched on or off, or all outputs can be set up at the same time by writing a single number to the output register which represents the status of all outputs.



An output watchdog timer can be configured to switch off all the outputs if there has been no communications with the module for up to 255 seconds. A value of 0 seconds will disable this timer and the outputs will remain in the last programmed state.

3.7.2 Technical Specification of PM4RO

Power Supply	Logic Supply Voltage	24 Vdc
	Logic Supply Current	42 mA
Relay Outputs	Output Points	4
	Maximum Current	0.5A @ 220VAC / 1A @ 28VDC
	Isolation	1000Vrms between field and logic 1000Vrms between outputs
Temperature	Operating Temperature.	-40°C to + 80°C
	Storage Temperature	-40°C to + 85°C
Connectors	Logic Power and Comms.	4 Pin Connector on underside of unit
	Outputs	18 Way screw connector on front

3.7.3 Status Indicators

Power: Flashes to indicate the CPU is running.

RS485 Rx: Flashes to indicate the unit has received a valid Modbus message.

RS485 Tx: Flashes to indicate the unit has sent a Modbus message.

Output Status: "OFF" when the output is off
 "ON" when the output is on.

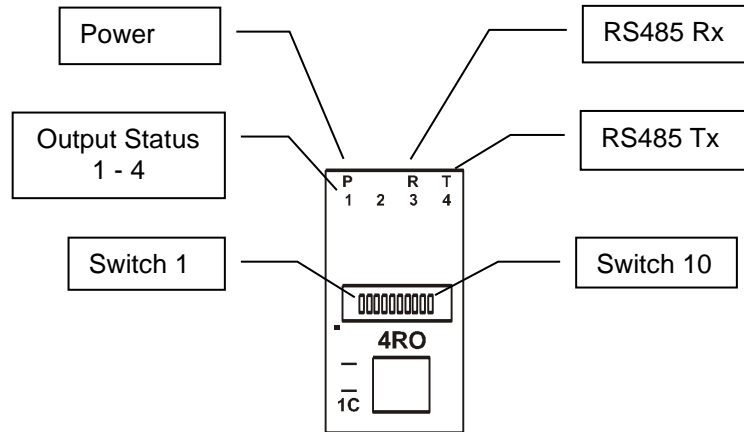

3.7.4 Wiring

The following diagram shows how the digital outputs are connected to the coil of a relay. The coil is connected to positive and switched to negative.

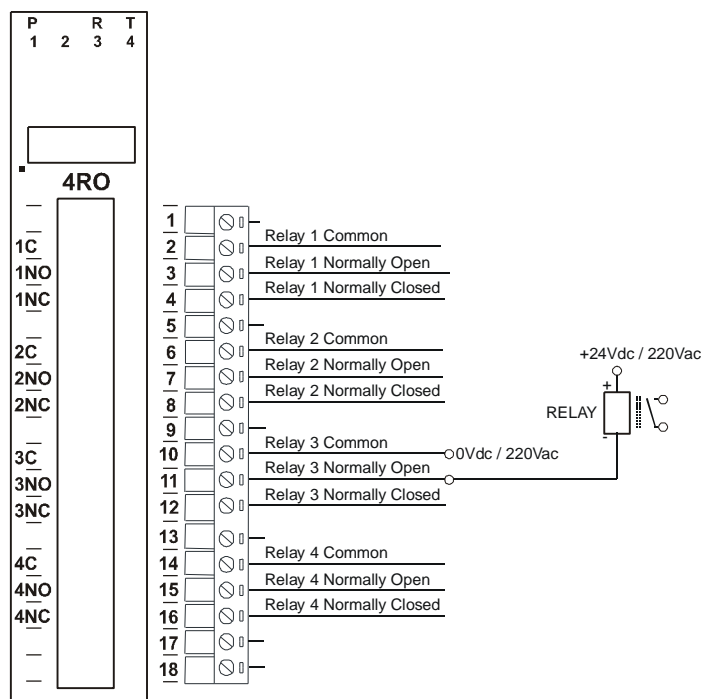

The following diagram shows the wiring for the power and RS485 communications.

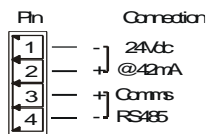

3.7.5 Switch Setting

<u>SWITCH</u>	<u>FUNCTION</u>	<u>DESCRIPTION</u>
1	NODE ID +1	Node ID's from 0 to 127 are set up using switches 1 to 7
2	NODE ID +2	"
3	NODE ID +4	"
4	NODE ID +8	"
5	NODE ID +16	"
6	NODE ID +32	"
7	NODE ID +64	"
8	-	Not Used.
9	MODE	Selects Master or Slave Mode. Master mode is used when the module is connected to a single digital input module. Slave mode is used when the module is to be polled either by the I/O Mapper or by a PC.
10	BAUD RATE	Selects 9600 (off) or Programmed Baud Rate (on)

3.7.6 PM4RO Data Registers (MODULE TYPE = 113)

Modbus Address	Register Name	Low Limit	High Limit	Access	Comments
00001	Relay Output 1	0	1	R/W	Status of Digital Outputs.
00002	Relay Output 2	0	1	R/W	"
00003	Relay Output 3	0	1	R/W	"
00004	Relay Output 4	0	1	R/W	"
30001	S/W Version / Module Type	N/A	N/A	R	High Byte = Software Version Low Byte = 113
40002	Digital Outputs	N/A	N/A	R/W	Digital Outputs in bits. xxxx xxxx xxxx 4,3,2,1 bit4(msb) – bit1(lsb).
30100	DIP Switch	0	65535	R	Status of DIP Switch on Front Panel
40101	Watchdog Timer	0	255	R/W	Timer in seconds. 0 = disabled. 1 - 255 = enabled.
40102	Master Timeout	0	65535	R/W	Modbus Master Timeout (X10ms)
40103	Master Poll Rate	0	65535	R/W	Modbus Master Poll Rate (X10ms)
40104	Output Mode	0	3	R/W	0=bits 1-4, 1=bits 5-8, 2=bits9-12, 3=bits 13-16 From version 3 upwards.
40121	Baud Rate	2400	18750	R/W	2400, 4800, 9600, 19200, 38400, 57600, 115200, 187500
40122	Parity	0	2	R/W	0 = none, 1 = even, 2 = odd
40123	Stop Bits	1	2	R/W	1 = 1 stop bit, 2 = 2 stop bits
40124	Reply Delay	0	255	R/W	0 = Disable, >0 = Enable. (x10ms)

3.7.6.1 Relay Output Register.

The relay outputs can be read/written in a single register as follows:

MSB		PM4RO DIGITAL OUTPUTS												LSB		ADDRESS
15	14	13	12	11	10	9	8	7	6	5	4	3	2	1	0	
32768	16384	8192	4096	2048	1024	512	256	128	64	32	16	8	4	2	1	40002
-	-	-	-	-	-	-	-	-	-	-	-	-	4	3	2	1

Relay Output

3.7.6.2 Output Watchdog Timer.

The watchdog timer is used to switch off all of the outputs in the event of a communications failure. When set to zero (register 40101) the watchdog timer is disabled.

3.7.7 Modbus Master Setup.

The module is configured as a Modbus master when switch 9 is on. The PM4RO reads digital inputs from a PM16DI module and writes the information to the outputs. The two modules must have the same network ID and these must be the only modules on the network.

3.7.7.1 Modbus Master Poll Rate.

The rate at which the PM4RO polls the PM16DI is configured using this register (40103). In some applications where a modem or radio is used in the RS485 network, it may be necessary to slow down the polling of the PM16DI due to turn around delays in the equipment.

3.7.7.2 Modbus Master Timeout.

The PM4RO polls the PM16DI to get the input data. If there is a problem and the message is corrupted or gets lost, then the PM4RO communications routine will timeout and try again. This parameter should be set to a larger value than the poll rate value.

3.8 PM8DIO - DIGITAL INPUTS / OUTPUTS

3.8.1 Description

The PM8DIO module is an 8 channel digital input and 8 channel digital output module.

The inputs are isolated from the logic by bi-directional opto-couplers. The common is connected internally to either the -volts or +volts field power supply terminals using a jumper link which is situated inside the housing.

The inputs have internal counters associated with them. These counters are 32 bit counters allowing a count value from 0 to 4294967295. The count value can be cleared by writing a zero to the associated registers or preset to any other value using the same method.

Note: The count values are not battery backed-up and will be lost if power is turned off.

The format of the registers allows the status of the inputs to be read as either single bits or all at once as a single register on the Modbus network.

The 8 digital outputs are open collector (NPN). The outputs may be used to drive lamps or external relays when more drive capability is required. The outputs are isolated from the logic and they share a common negative terminal.

The module may be used as either a slave or master on the Modbus network. When used with a PC or PLC the module will be configured as a slave. When used with another PM8DIO module in a point-to-point configuration, the DIP switch 9 must be turned on to set the module up as a master. In this mode the PM8DIO module will automatically read/write the information from/to the other PM8DIO module.

When used as a slave module, the outputs are written to by the Modbus master device such as a PC or PLC. Each output can be individually switched on or off, or all outputs can be set up at the same time by writing a single number to the output register which represents the status of all outputs.

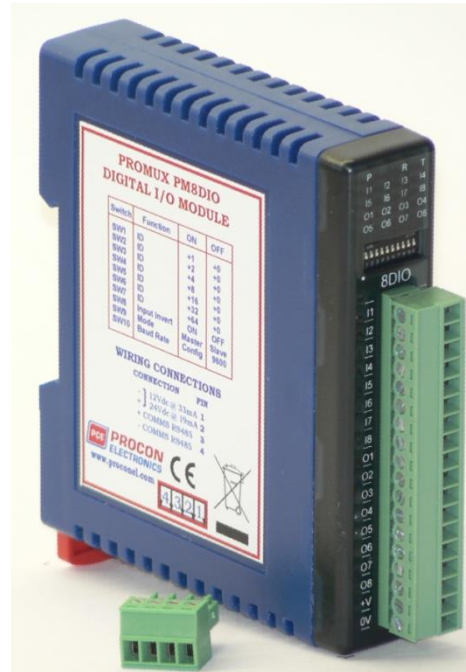

3.8.2 Technical Specification of PM8DIO

Power Supply	Logic Supply Voltage	12 -24 Vdc
	Logic Supply Current	33mA @ 12V / 19mA @ 24V
	Field Supply Voltage	12 -24 Vdc
	Field Supply Current	6mA @ 12V / 6mA @ 24V
Digital Inputs	Input Points	8
	Input Voltage Range	12 -24 Vdc
	Input Current per input	5mA@12Vdc / 11mA @24Vdc
	Isolation	1500Vrms between field and logic
Digital Outputs	Output Points	8
	Maximum Voltage	36 Vdc
	Maximum Current	100 mA per output
	Vceon	1.1V Max.
Counters	Inputs	1 to 16
	Resolution	32 Bits
	Frequency	1KHz (max)
	Pulse Width	500us (min)
Temperature	Operating Temperature.	-40°C to + 80°C
	Storage Temperature	-40°C to + 85°C
Connectors	Logic Power and Comms.	4 Pin Connector on underside of unit
	Outputs	18 Way screw connector on front

Note: Inputs 1 to 8 are used as both digital inputs and counter inputs.

3.8.3 Status Indicators

Power: Flashes to indicate the CPU is running.

RS485 Rx: Flashes to indicate the unit has received a valid Modbus message.

RS485 Tx: Flashes to indicate the unit has sent a Modbus message.

Input Status: "OFF" when the input is off

"ON" when the input is on.

Output Status: "OFF" when the output is off

"ON" when the output is on.

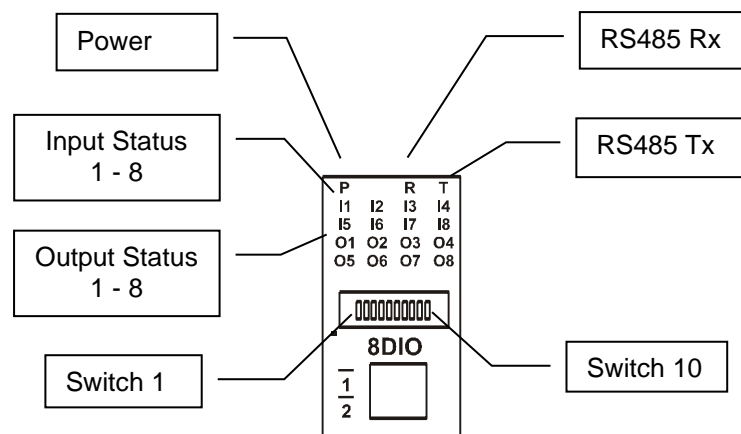

3.8.4 Wiring

The following diagram shows how the digital inputs and outputs are connected.

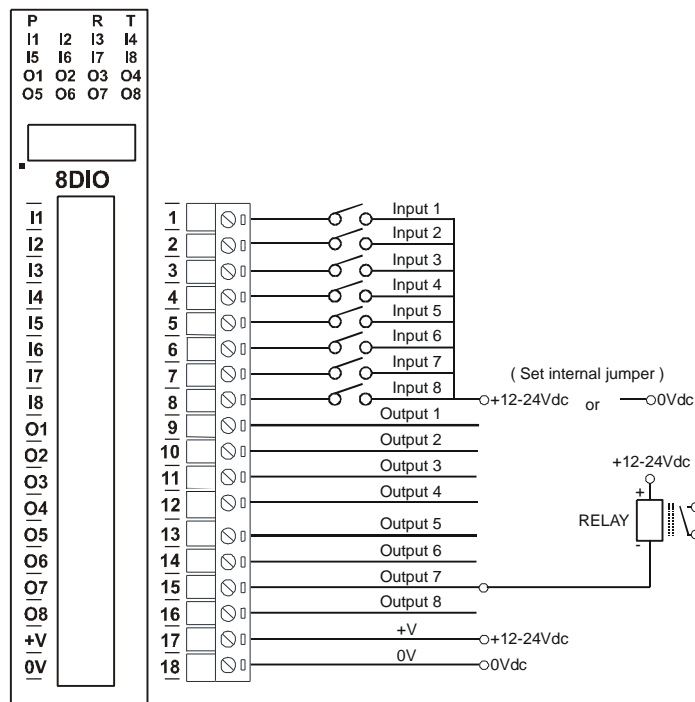

The following diagram shows the wiring for the power and RS485 communications.

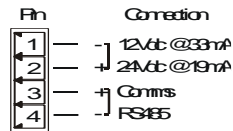

3.8.5 Switch Settings

SWITCH	FUNCTION	DESCRIPTION
1	NODE ID +1	Node ID's from 0 to 127 are set up using switches 1 to 7
2	NODE ID +2	"
3	NODE ID +4	"
4	NODE ID +8	"
5	NODE ID +16	"
6	NODE ID +32	"
7	NODE ID +64	"
8	INVERT	When switched ON the status of the inputs are inverted in the Modbus status register (30002).
9	MODE	Selects Master or Slave Mode. Master mode is used when the module is connected to a single digital input module. Slave mode is used when the module is to be polled either by the I/O Mapper or by a PC.
10	BAUD RATE	Selects 9600 (off) or Programmed Baud Rate (on)

3.8.6 Setting the jumpers for NPN inputs.

The Digital inputs can be configured as NPN inputs. This means that the inputs can be operated by switching to 0V. Change the link **LK1** to the NPN position.

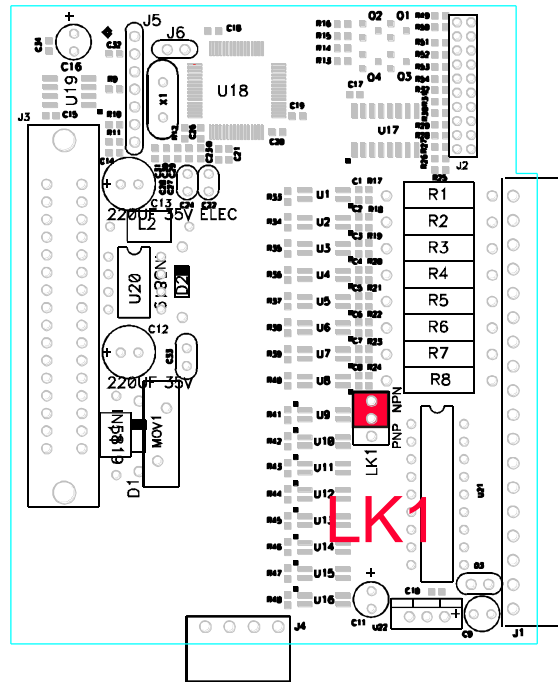

3.8.7 Setting the jumpers for PNP inputs.

The Digital inputs can be configured as PNP inputs. This means that the inputs can be operated by switching to +12V to +24V. Change the link **LK1** to the PNP position.

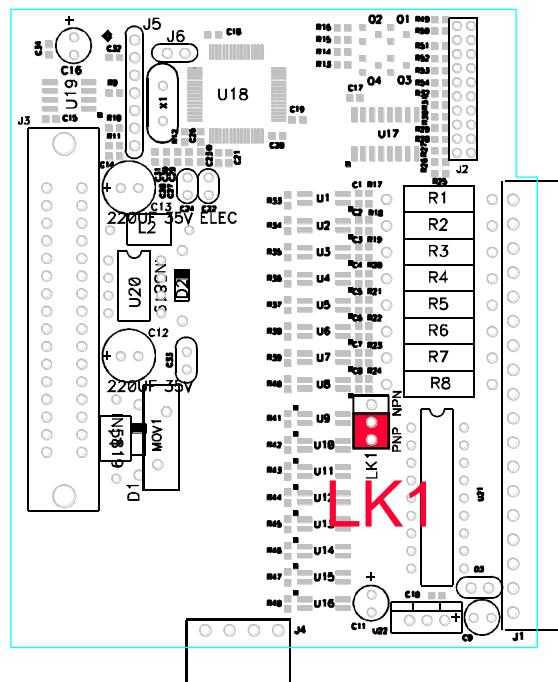

3.8.8 PM8DIO Data Registers (MODULE TYPE = 102)

Modbus Address	Register Name	Low Limit	High Limit	Access	Comments
10001	Digital Input 1	0	1	R	Status of Digital Inputs.
10002	Digital Input 2	0	1	R	"
10003	Digital Input 3	0	1	R	"
10004	Digital Input 4	0	1	R	"
10005	Digital Input 5	0	1	R	"
10006	Digital Input 6	0	1	R	"
10007	Digital Input 7	0	1	R	"
10008	Digital Input 8	0	1	R	"
00017	Digital Output 1	0	1	R/W	Status of Digital Outputs.
00018	Digital Output 2	0	1	R/W	"
00019	Digital Output 3	0	1	R/W	"
00020	Digital Output 4	0	1	R/W	"
00021	Digital Output 5	0	1	R/W	"
00022	Digital Output 6	0	1	R/W	"
00023	Digital Output 7	0	1	R/W	"
00024	Digital Output 8	0	1	R/W	"
30001	S/W Version / Module Type	N/A	N/A	R	High Byte = Software Version Low Byte = 102
30002	Digital Inputs	N/A	N/A	R	Digital Inputs in lower 8 bits. 8 - 1.
40003	Digital Outputs	N/A	N/A	R/W	Digital Outputs in lower 8 bits. 8 - 1.
40004	Counter 1 MSB	0	65535	R/W	Counter MSB and LSB combine to give a 32 bit
40005	Counter 1 LSB	0	65535	R/W	Counter with range 0 to 4294967295.
40006	Counter 2 MSB	0	65535	R/W	"
40007	Counter 2 LSB	0	65535	R/W	"
40008	Counter 3 MSB	0	65535	R/W	"
40009	Counter 3 LSB	0	65535	R/W	"
40010	Counter 4 MSB	0	65535	R/W	"
40011	Counter 4 LSB	0	65535	R/W	"
40012	Counter 5 MSB	0	65535	R/W	"
40013	Counter 5 LSB	0	65535	R/W	"
40014	Counter 6 MSB	0	65535	R/W	"
40015	Counter 6 LSB	0	65535	R/W	"
40016	Counter 7 MSB	0	65535	R/W	"
40017	Counter 7 LSB	0	65535	R/W	"
40018	Counter 8 MSB	0	65535	R/W	"
40019	Counter 8 LSB	0	65535	R/W	"
30100	DIP Switch	0	65535	R	Status of DIP Switch on Front Panel
40101	Watchdog Timer	0	255	R/W	Timer in seconds. 0 = disabled. 1 - 255 = enabled.
40102	Master Timeout	0	65535	R/W	Modbus Master Timeout (X10ms)

40103	Master PollRate	0	65535	R/W	Modbus Master Poll Rate (X10ms)
40105	Counter Mode	0	2	R/W	0=Disable, 1=Up Counting, 2=Up/Down Count
40106	Input Filter	0	65535	R/W	0 = Disable, >0 = Enable. (x10ms)
40121	Baud Rate	2400	18750	R/W	2400, 4800, 9600, 19200, 38400, 57600, 115200, 187500
40122	Parity	0	2	R/W	0 = none, 1 = even, 2 = odd
40123	Stop Bits	1	2	R/W	1 = 1 stop bit, 2 = 2 stop bits
40124	Reply Delay	0	255	R/W	0 = Disable, >0 = Enable. (x10ms)

3.8.8.1 Digital Input Register.

The digital inputs can be read in a single register as follows:

MSB		PM8DIO DIGITAL INPUTS										LSB				ADDRESS
15	14	13	12	11	10	9	8	7	6	5	4	3	2	1	0	
32768	16384	8192	4096	2048	1024	512	256	128	64	32	16	8	4	2	1	30002
0	0	0	0	0	0	0	0	0	8	7	6	5	4	3	2	1

Digital Input Number

3.8.8.2 Digital Output Register.

The digital outputs can be read/written in a single register as follows:

MSB		PM8DIO DIGITAL OUTPUTS										LSB				ADDRESS
15	14	13	12	11	10	9	8	7	6	5	4	3	2	1	0	
32768	16384	8192	4096	2048	1024	512	256	128	64	32	16	8	4	2	1	40003
0	0	0	0	0	0	0	0	0	8	7	6	5	4	3	2	1

Digital Output Number

3.8.8.3 Counter Registers.

The counters are stored a two 16 bit registers. The first register is the High Register and the second register is the Low Register. To get the actual 32 bit count value the registers must be combined as follows:

Counter High Value = Register 40003.

Counter Low Value = Register 40004.

Counter Value = (Counter High Value X 65536) + Counter Low Value.

3.8.8.4 Output Watchdog Timer.

The watchdog timer is used to switch off all of the outputs in the event of a communications failure. When set to zero (register 40101) the watchdog timer is disabled.

3.8.9 Modbus Master Setup.

The module is configured as a Modbus master when switch 9 is on. The PM8DIO reads digital inputs from a second PM8DIO module and writes the information to the outputs. The PM8DIO also writes digital inputs to the a second PM8DIO module. This results in data being transferred on both directions between the two PM8DIO modules. The two modules must have the same network ID and these must be the only modules on the network.

3.8.9.1 Modbus Master Poll Rate.

The rate at which the PM8DIO polls the second PM8DIO is configured using this register (40103). In some applications where a modem or radio is used in the RS485 network, it may be necessary to slow down the polling of the PM8DIO due to turn around delays in the equipment.

3.8.9.2 Modbus Master Timeout.

The PM8DIO polls the second PM8DIO to get the input data. If there is a problem and the message is corrupted or gets lost, then the PM8DIO communications routine will timeout and try again. This parameter should be set to a larger value than the poll rate value.

3.9 PM8DIO-24VAC - DIGITAL INPUTS / OUTPUTS

3.9.1 Description

The PM8DIO-24VAC module is an 8 channel digital input and 8 channel digital output module.

The inputs can accept either 24V AC or DC voltages. The inputs are isolated from the logic by bi-directional opto-couplers. The common is connected internally to either the -volts or +volts field power supply terminals using a jumper link which is situated inside the housing.

The inputs have internal counters associated with them. These counters are 32 bit counters allowing a count value from 0 to 4294967295. The count value can be cleared by writing a zero to the associated registers or preset to any other value using the same method.

Note: The count values are not battery backed-up and will be lost if power is turned off.

The format of the registers allows the status of the inputs to be read as either single bits or all at once as a single register on the Modbus network.

The 8 digital outputs are open collector (NPN). The outputs may be used to drive lamps or external relays when more drive capability is required. The outputs are isolated from the logic and they share a common negative terminal.

The module may be used as either a slave or master on the Modbus network. When used with a PC or PLC the module will be configured as a slave. When used with another PM8DIO module in a point-to-point configuration, the DIP switch 9 must be turned on to set the module up as a master. In this mode the PM8DIO module will automatically read/write the information from/to the other PM8DIO module.

When used as a slave module, the outputs are written to by the Modbus master device such as a PC or PLC. Each output can be individually switched on or off, or all outputs can be set up at the same time by writing a single number to the output register which represents the status of all outputs.



3.9.2 Technical Specification of PM8DIO-24VAC

Power Supply	Logic Supply Voltage	12 -24 Vdc
	Logic Supply Current	33mA @ 12V / 19mA @ 24V
	Field Supply Voltage	12 -24 Vdc
	Field Supply Current	6mA @ 12V / 6mA @ 24V
Digital Inputs	Input Points	8
	Input Voltage Range	12 -24 Vdc
	Input Current per input	5mA@12Vdc / 11mA @24Vdc
	Isolation	1500Vrms between field and logic
Digital Outputs	Output Points	8
	Maximum Voltage	36 Vdc
	Maximum Current	100 mA per output
	Vceon	1.1V Max.
Counters	Inputs	1 to 16
	Resolution	32 Bits
	Frequency	10Hz (max)
	Pulse Width	50ms (min)
Temperature	Operating Temperature.	-40°C to + 80°C
	Storage Temperature	-40°C to + 85°C
Connectors	Logic Power and Comms.	4 Pin Connector on underside of unit
	Outputs	18 Way screw connector on front

Note: Inputs 1 to 8 are used as both digital inputs and counter inputs.

3.9.3 Status Indicators

Power: Flashes to indicate the CPU is running.

RS485 Rx: Flashes to indicate the unit has received a valid Modbus message.

RS485 Tx: Flashes to indicate the unit has sent a Modbus message.

Input Status: "OFF" when the input is off

"ON" when the input is on.

Output Status: "OFF" when the output is off

"ON" when the output is on.

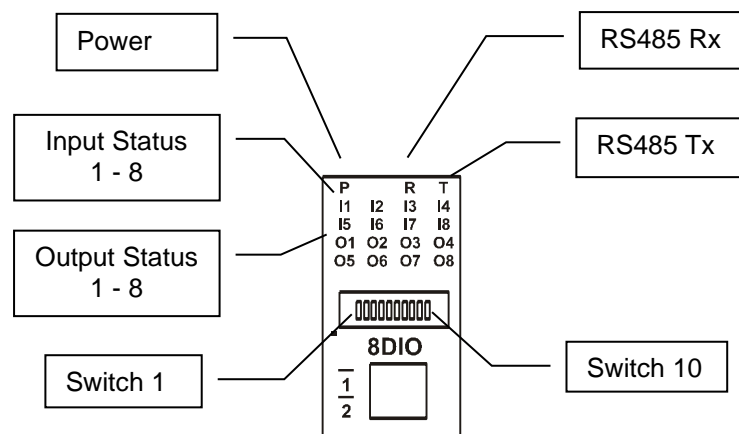

3.9.4 Wiring

The following diagram shows how the digital inputs and outputs are connected.

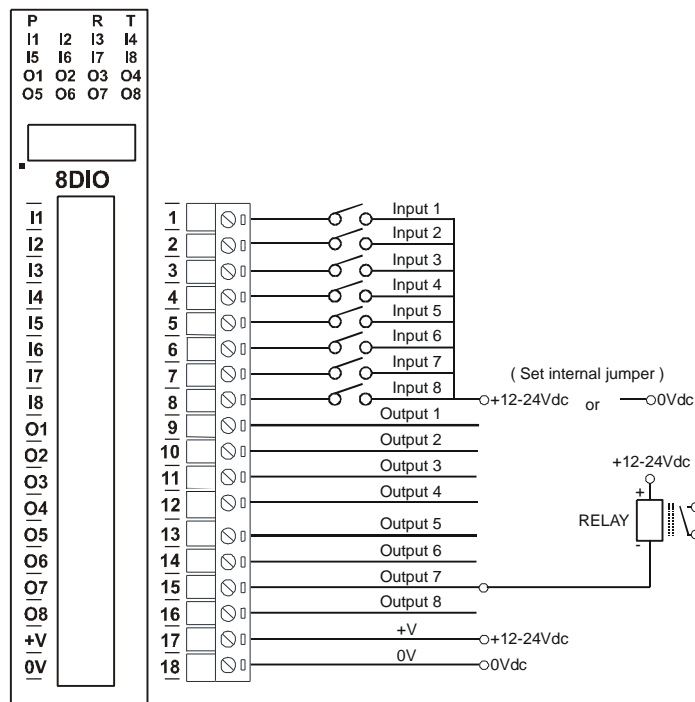

The following diagram shows the wiring for the power and RS485 communications.

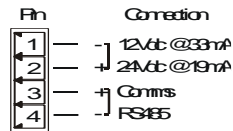

3.9.5 Switch Settings

SWITCH	FUNCTION	DESCRIPTION
1	NODE ID +1	Node ID's from 0 to 127 are set up using switches 1 to 7
2	NODE ID +2	"
3	NODE ID +4	"
4	NODE ID +8	"
5	NODE ID +16	"
6	NODE ID +32	"
7	NODE ID +64	"
8	INVERT	When switched ON the status of the inputs are inverted in the Modbus status register (30002).
9	MODE	Selects Master or Slave Mode. Master mode is used when the module is connected to a single digital input module. Slave mode is used when the module is to be polled either by the I/O Mapper or by a PC.
10	BAUD RATE	Selects 9600 (off) or Programmed Baud Rate (on)

3.9.6 Setting the jumpers for NPN inputs.

The Digital inputs can be configured as NPN inputs. This means that the inputs can be operated by switching to 0V. Change the link **LK1** to the NPN position.

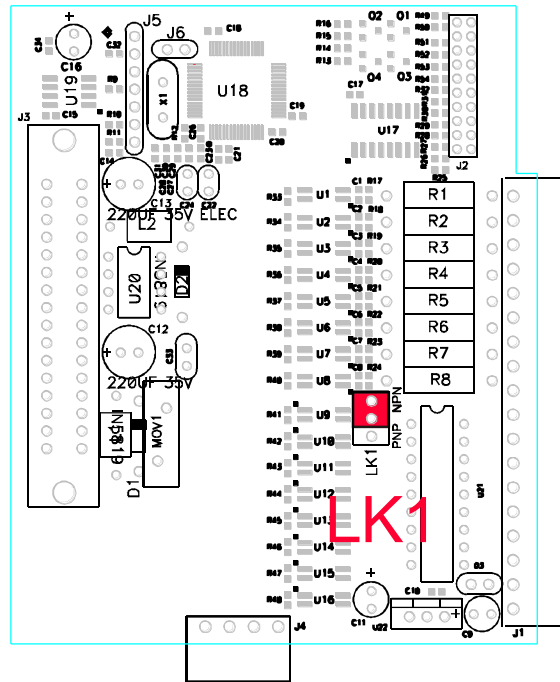

3.9.7 Setting the jumpers for PNP inputs.

The Digital inputs can be configured as PNP inputs. This means that the inputs can be operated by switching to +12V to +24V. Change the link **LK1** to the PNP position.

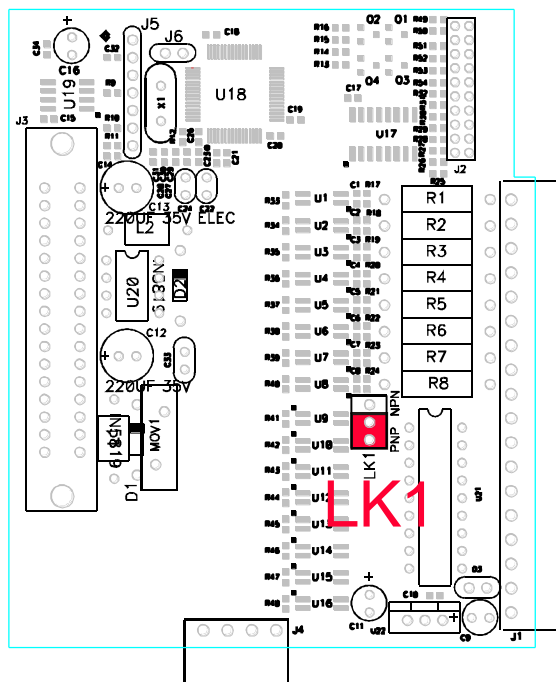

3.9.8 PM8DIO-24VAC Data Registers (MODULE TYPE = 102)

Modbus Address	Register Name	Low Limit	High Limit	Access	Comments
10001	Digital Input 1	0	1	R	Status of Digital Inputs.
10002	Digital Input 2	0	1	R	"
10003	Digital Input 3	0	1	R	"
10004	Digital Input 4	0	1	R	"
10005	Digital Input 5	0	1	R	"
10006	Digital Input 6	0	1	R	"
10007	Digital Input 7	0	1	R	"
10008	Digital Input 8	0	1	R	"
00017	Digital Output 1	0	1	R/W	Status of Digital Outputs.
00018	Digital Output 2	0	1	R/W	"
00019	Digital Output 3	0	1	R/W	"
00020	Digital Output 4	0	1	R/W	"
00021	Digital Output 5	0	1	R/W	"
00022	Digital Output 6	0	1	R/W	"
00023	Digital Output 7	0	1	R/W	"
00024	Digital Output 8	0	1	R/W	"
30001	S/W Version / Module Type	N/A	N/A	R	High Byte = Software Version Low Byte = 102
30002	Digital Inputs	N/A	N/A	R	Digital Inputs in lower 8 bits. 8 - 1.
40003	Digital Outputs	N/A	N/A	R/W	Digital Outputs in lower 8 bits. 8 - 1.
40004	Counter 1 MSB	0	65535	R/W	Counter MSB and LSB combine to give a 32 bit
40005	Counter 1 LSB	0	65535	R/W	Counter with range 0 to 4294967295.
40006	Counter 2 MSB	0	65535	R/W	"
40007	Counter 2 LSB	0	65535	R/W	"
40008	Counter 3 MSB	0	65535	R/W	"
40009	Counter 3 LSB	0	65535	R/W	"
40010	Counter 4 MSB	0	65535	R/W	"
40011	Counter 4 LSB	0	65535	R/W	"
40012	Counter 5 MSB	0	65535	R/W	"
40013	Counter 5 LSB	0	65535	R/W	"
40014	Counter 6 MSB	0	65535	R/W	"
40015	Counter 6 LSB	0	65535	R/W	"
40016	Counter 7 MSB	0	65535	R/W	"
40017	Counter 7 LSB	0	65535	R/W	"
40018	Counter 8 MSB	0	65535	R/W	"
40019	Counter 8 LSB	0	65535	R/W	"
30100	DIP Switch	0	65535	R	Status of DIP Switch on Front Panel
40101	Watchdog Timer	0	255	R/W	Timer in seconds. 0 = disabled. 1 - 255 = enabled.
40102	Master Timeout	0	65535	R/W	Modbus Master Timeout (X10ms)

40103	Master PollRate	0	65535	R/W	Modbus Master Poll Rate (X10ms)
40105	Counter Mode	0	2	R/W	0=Disable, 1=Up Counting, 2=Up/Down Count
40106	Input Filter	0	65535	R/W	0 = Disable, >0 = Enable. (x10ms)
40121	Baud Rate	2400	18750	R/W	2400, 4800, 9600, 19200, 38400, 57600, 115200, 187500
40122	Parity	0	2	R/W	0 = none, 1 = even, 2 = odd
40123	Stop Bits	1	2	R/W	1 = 1 stop bit, 2 = 2 stop bits
40124	Reply Delay	0	255	R/W	0 = Disable, >0 = Enable. (x10ms)

3.9.8.1 Digital Input Register.

The digital inputs can be read in a single register as follows:

MSB		PM8DIO DIGITAL INPUTS												LSB		ADDRESS
15	14	13	12	11	10	9	8	7	6	5	4	3	2	1	0	
32768	16384	8192	4096	2048	1024	512	256	128	64	32	16	8	4	2	1	30002
0	0	0	0	0	0	0	0	0	8	7	6	5	4	3	2	1

Digital Input Number

3.9.8.2 Digital Output Register.

The digital outputs can be read/written in a single register as follows:

MSB		PM8DIO DIGITAL OUTPUTS												LSB		ADDRESS
15	14	13	12	11	10	9	8	7	6	5	4	3	2	1	0	
32768	16384	8192	4096	2048	1024	512	256	128	64	32	16	8	4	2	1	40003
0	0	0	0	0	0	0	0	0	8	7	6	5	4	3	2	1

Digital Output Number

3.9.8.3 Counter Registers.

The counters are stored a two 16 bit registers. The first register is the High Register and the second register is the Low Register. To get the actual 32 bit count value the registers must be combined as follows:

Counter High Value = Register 40003.

Counter Low Value = Register 40004.

Counter Value = (Counter High Value X 65536) + Counter Low Value.

3.9.8.4 Output Watchdog Timer.

The watchdog timer is used to switch off all of the outputs in the event of a communications failure. When set to zero (register 40101) the watchdog timer is disabled.

3.9.9 Modbus Master Setup.

The module is configured as a Modbus master when switch 9 is on. The PM8DIO reads digital inputs from a second PM8DIO module and writes the information to the outputs. The PM8DIO also writes digital inputs to the a second PM8DIO module. This results in data being transferred on both directions between the two PM8DIO modules. The two modules must have the same network ID and these must be the only modules on the network.

3.9.9.1 Modbus Master Poll Rate.

The rate at which the PM8DIO polls the second PM8DIO is configured using this register (40103). In some applications where a modem or radio is used in the RS485 network, it may be necessary to slow down the polling of the PM8DIO due to turn around delays in the equipment.

3.9.9.2 Modbus Master Timeout.

The PM8DIO polls the second PM8DIO to get the input data. If there is a problem and the message is corrupted or gets lost, then the PM8DIO communications routine will timeout and try again. This parameter should be set to a larger value than the poll rate value.

3.10 PM8AI/I and PM8AI/V - ANALOG INPUTS

3.10.1 Description

The Analog Input modules are supplied as either a current input module (PM8AI/I) or a voltage input module (PM8AI/V). The inputs are isolated from the logic and share a common negative terminal.

The standard setting for the PM8AI/I module is 0 - 20mA input current which represents an output value of 0 - 4095 (12 bits) in the corresponding Modbus register. To obtain an output value of 0 to 4095 for an input signal of 4 to 20mA the offset switch is switched on.

The same applies to the PM8AI/V module. An input voltage of 0 - 10Volts represents an output of 0 - 4095 and 2 volts would give a reading of $819 \pm 1\text{LSB}$. To obtain an output value of 0 to 4095 for an input signal of 2 to 10V the offset switch is switched on. An input range of 0(1) to 5Vdc is available by removing the jumper link located on the analog board inside the enclosure.



3.10.2 Technical Specification of PM8AI/I and PM8AI/V

Power Supply	Logic Supply Voltage	12 -24 Vdc
	Logic Supply Current	27mA @ 12V / 16mA @ 24V
	Field Supply Voltage	12 -24 Vdc
	Field Supply Current	8mA @ 12V / 15mA @ 24V
Voltage Inputs – PM8AI/V	Input Points	8
	Input Voltage	0(2) - 10 Vdc or 0(1) - 5 Vdc
	Input Resistance	200kohms
	Resolution	12 bits
	Drift	50ppm/°C
	Accuracy	0.2% of span
	Isolation	1500Vrms between field and logic
Current Inputs – PM8AI/I	Input Points	8
	Input Current	0(4) - 20 mA
	Input Resistance	250ohms
	Resolution	12 bits
	Drift	50ppm/°C
	Accuracy	0.2% of span
	Isolation	1500Vrms between field and logic
Temperature	Operating Temperature.	-40°C to + 80°C
	Storage Temperature	-40°C to + 85°C
Connectors	Logic Power and Comms.	4 Pin Connector on underside of unit
	Inputs	18 Way screw connector on front

3.10.3 Status Indicators

- Power:** Flashes to indicate the CPU is running.
- RS485 Rx:** Flashes to indicate the unit has received a valid Modbus message.
- RS485 Tx:** Flashes to indicate the unit has sent a Modbus message.
- Input Status:** "ON" when the input is zero.
"OFF" when the input is greater than zero and less than 4095 (or 65535).
"Flashing" when the input is over range, greater or equal to 4095 (or 65535).

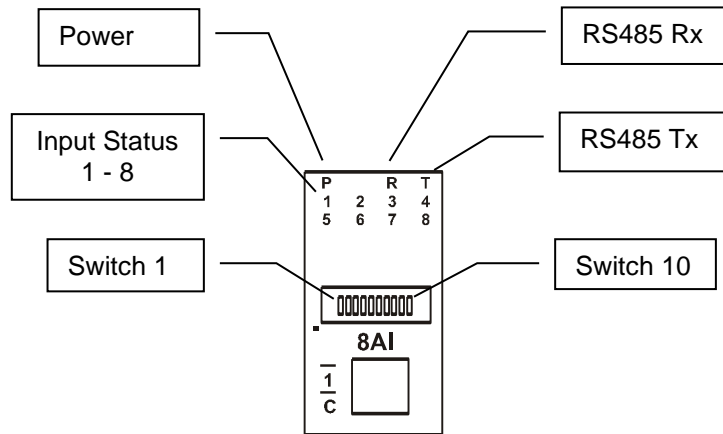

3.10.4 Wiring

The following diagram shows how the analog inputs are connected to a 0(4)-20mA source. All of the common terminals are connected together, and are connected to 0V internally.

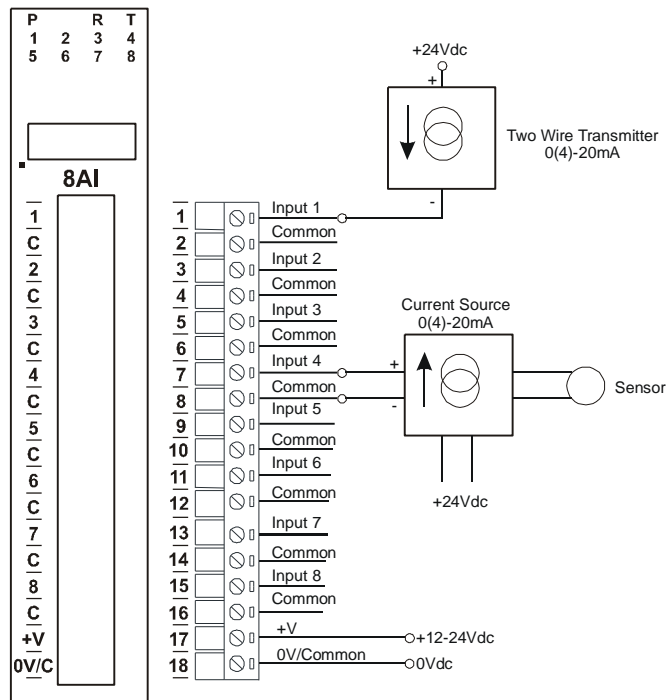

The following diagram shows how the analog inputs are connected to a 0(2)-10Vdc source. All of the common terminals are connected together, and are connected to 0V internally.

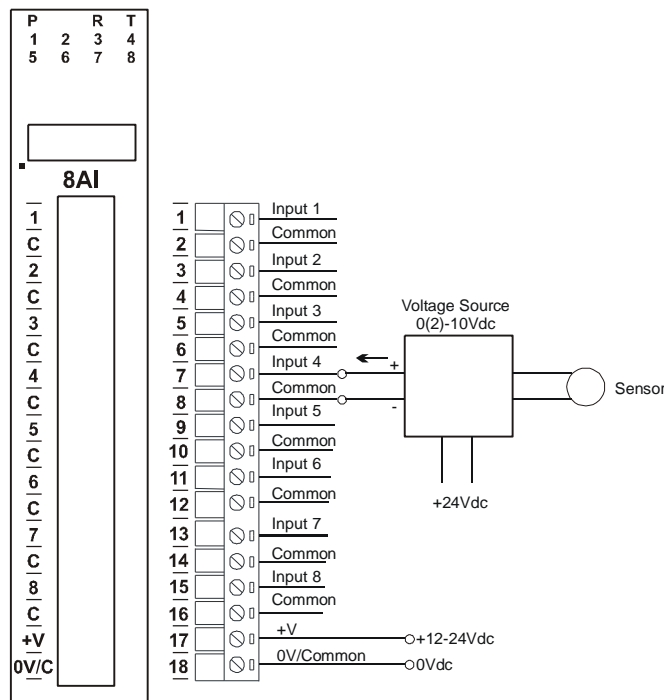

The following diagram shows the wiring for the power and RS485 communications.

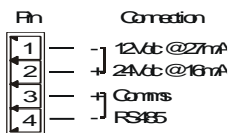

3.10.5 Switch Settings

SWITCH	FUNCTION	DESCRIPTION
1	NODE ID +1	Node ID's from 0 to 127 are set up using switches 1 to 7
2	NODE ID +2	"
3	NODE ID +4	"
4	NODE ID +8	"
5	NODE ID +16	"
6	NODE ID +32	"
7	NODE ID +64	"
8	-	Not used.
9	OFFSET	When switched ON the inputs scaled to accept a 2V or 4mA offset.
10	BAUD RATE	Selects 9600 (off) or Programmed Baud Rate (on)

3.10.6 PM8AI Data Registers (PM8AI/I TYPE = 103 / PM8AI/V TYPE = 104)

Modbus Address	Register Name	Low Limit	High Limit	Access	Description
30001	S/W Version / Module Type	N/A	N/A	R	High Byte = Software Version Low Byte = 103(PM8AI/I) or 104(PM8AI/V)
30002	Analog Input 1	0	4095	R	Analog Input lower 12 Bits
30003	Analog Input 2	0	4095	R	"
30004	Analog Input 3	0	4095	R	"
30005	Analog Input 4	0	4095	R	"
30006	Analog Input 5	0	4095	R	"
30007	Analog Input 6	0	4095	R	"
30008	Analog Input 7	0	4095	R	"
30009	Analog Input 8	0	4095	R	"
30010	Input Status	0	65535	R	bit2 = 0(open circuit or < 2), bit2 = 1(over range) bit1 = 0(OK), bit1 = 1(error)
30011	Input Alarm Status	0	255	R	bit1 = 0(OK), bit1 = 1(input < 2mA) (Version 6 onwards)
30100	DIP Switch	0	65535	R	Status of DIP Switch on Front Panel
40121	Baud Rate	2400	18750	R/W	2400, 4800, 9600, 19200, 38400, 57600, 115200, 187500
40122	Parity	0	2	R/W	0 = none, 1 = even, 2 = odd
40123	Stop Bits	1	2	R/W	1 = 1 stop bit, 2 = 2 stop bits
40124	Reply Delay	0	255	R/W	0 = Disable, >0 = Enable. (x10ms)

3.10.6.1 Analog Input Registers (12bit).

The analog inputs are read as a 12 bit value in the registers as follows:

MSB		PM8AI ANALOG INPUTS												LSB		ADDRESS
15	14	13	12	11	10	9	8	7	6	5	4	3	2	1	0	
32768	16384	8192	4096	2048	1024	512	256	128	64	32	16	8	4	2	1	300XX
0	0	0	0	x	x	x	x	x	x	x	x	x	x	x	x	

Analog Input: 12 Bit Value (0 - 4095)

3.10.6.2 Analog Input Status.

There are two status bits associated with each analog input. These bits are used to indicate if the input is zero or open circuit, in the working range 0-4095, or over range. If the input is open circuit or over range, then the error bit will be set. When the error bit is set, the range bit is zero if the input is open circuit and set if the input is over range, ie:

<u>Bit 1- Error</u>	<u>Bit 2-Range</u>	<u>Condition</u>	<u>Status LED</u>
0	don't care	Input working OK.	(LED OFF)
1	0	Input Open circuit or zero.	(LED ON)
1	1	Input Over range.	(LED FLASH)

The analog input status can be read in a single register as follows:

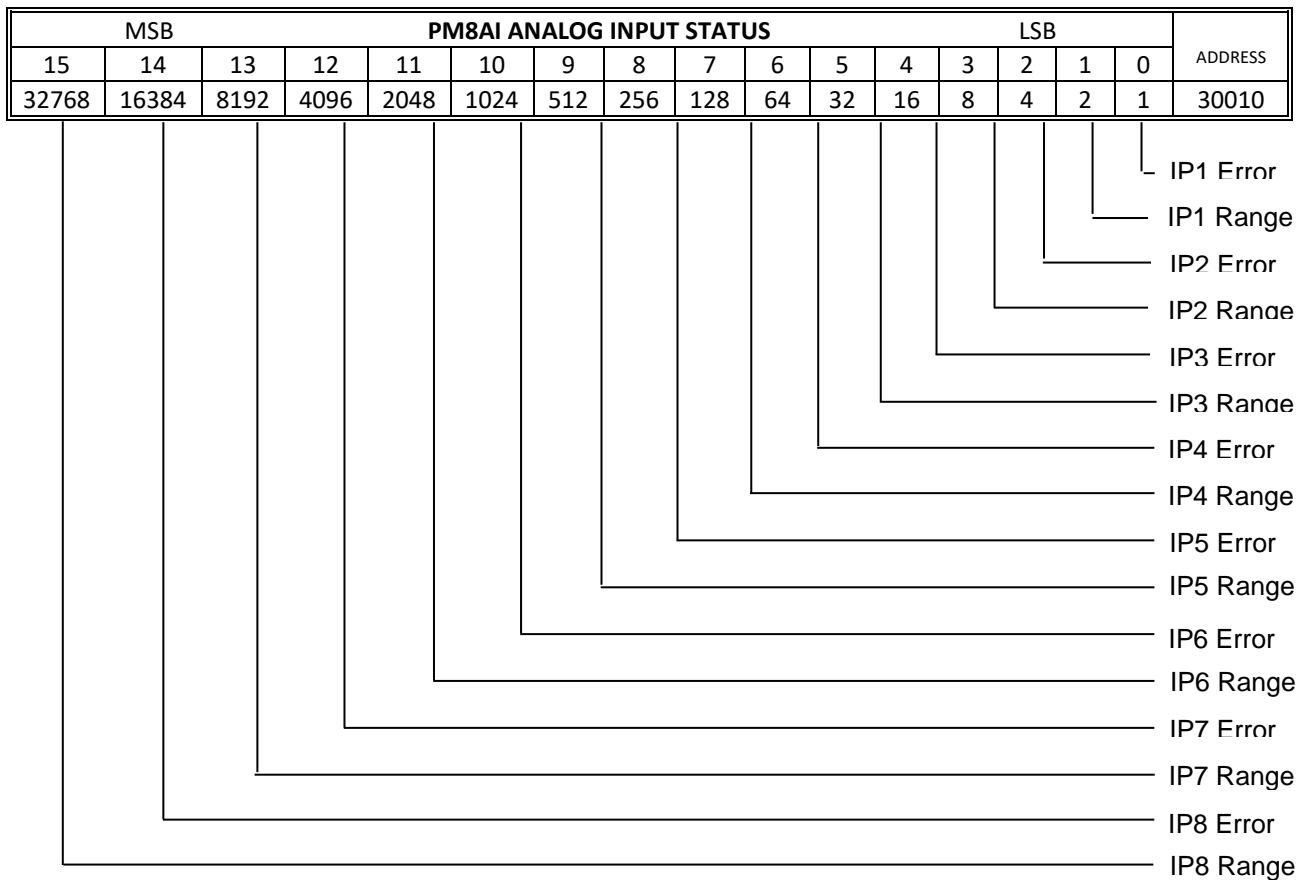

3.10.6.3 Analog Input Alarm Status.

There is one alarm status bit associated with each analog input. The alarm bits are used to indicate if the 4-20mA current loop is broken and the bit will be set if the loop current is less than 2mA.

For the voltage module there is one alarm status bit associated with each voltage input. The alarm bits are used to indicate if the 2-10V voltage input is broken and the bit will be set if the input voltage is less than 1V.

The analog input alarm status can be read in a single register as follows:

MSB		PM8AI ANALOG INPUT ALARM STATUS													LSB		ADDRESS
15	14	13	12	11	10	9	8	7	6	5	4	3	2	1	0		
32768	16384	8192	4096	2048	1024	512	256	128	64	32	16	8	4	2	1	30011	

3.11 PM8AI/I ISO and PM8AI/V ISO - ISOLATED ANALOG INPUTS

3.11.1 Description

The Analog Input modules are supplied as either a current input module (PM8AI/I ISO) or a voltage input module (PM8AI/V ISO). The inputs are fully isolated from input to logic and between inputs. This module is ideal for monitoring existing 4-20mA current loops which are isolated from each other and cannot be connected to a common point of reference.

The PM8AI/I ISO module can be configured for 12bits or 16bits resolution. The **16-bit** option is available in modules with software version 8 and higher. The standard setting for the PM8AI/I ISO module is 0 - 20mA input current which represents an output value of 0 - 4095 (12 bits) in the corresponding Modbus register. To obtain an output value of 0 to 4095 for an input signal of 4 to 20mA the offset switch is switched on. This module can also be configured for a 0 – 20.000mA input range or +/- 20.000mA input. The module also supports 14-bit and 16-bit ranges.



The same applies to the PM8AI/V ISO module. An input voltage of 0 - 10Volts represents an output of 0 - 4095 and 2 volts would give a reading of $819 \pm 1\text{LSB}$. To obtain an output value of 0 to 4095 for an input signal of 2 to 10V the offset switch is switched on. This module can also be configured for a 0 – 10.000V input range or +/- 10.000V input. The module also supports 14-bit and 16-bit ranges.

3.11.2 Technical Specification of PM8AI/I ISO and PM8AI/V ISO

Power Supply	Logic Supply Voltage	12 -24 Vdc	
	Logic Supply Current	58mA @ 12V / 31mA @ 24V	
Voltage Inputs – PM8AI/V ISO	Input Points	8	
	Input Voltage	0(2) - 10 Vdc	
	InputType	Range	Resolution
	1	0 – 4095	12 bits
	2	0 – 10.000 V	1mV
	3	+/- 10.000 V	1mV
	4	0 – 1.0000 V	0.1mV
	5	+/- 1.0000 V	0.1mV
	6	0 - 16383	14 bits (version 8 onwards)
	7	0 - 65535	16 bits (version 8 onwards)
	Drift	100ppm/°C	
Isolation	1500Vrms between field and logic 350Vpeak between each input		
Current Inputs – PM8AI/I ISO	Input Points	8	
	Input Current	0(4) - 20 mA	
	InputType	Range	Resolution
	1	0 – 4095	12 bits
	2	0–20.000mA	1uA
	3	+/-20.000mA	1uA
	4	0 - 16383	14 bits (version 8 onwards)
	5	0 - 65535	16 bits (version 8 onwards)
Drift	100ppm/°C		
Isolation	1500Vrms between field and logic 350Vpeak between each input		
Temperature	Operating Temperature.	-40°C to + 80°C	
	Storage Temperature	-40°C to + 85°C	
Connectors	Logic Power and Comms.	4 Pin Connector on underside of unit	
	Inputs	18 Way screw connector on front	

3.11.3 Status Indicators

- Power:** Flashes to indicate the CPU is running.
- RS485 Rx:** Flashes to indicate the unit has received a valid Modbus message.
- RS485 Tx:** Flashes to indicate the unit has sent a Modbus message.
- Input Status:** "ON" when the input is zero.
"OFF" when the input is greater than zero and less than 4095.
"Flashing" when the input is over range, greater or equal to 4095.

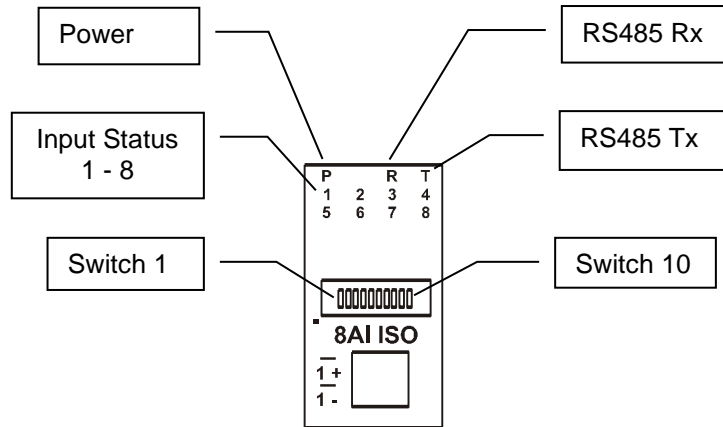

3.11.4 Wiring

The following diagram shows how the analog inputs are connected to a 0(4)-20mA source. All of the common terminals are isolated from each other.

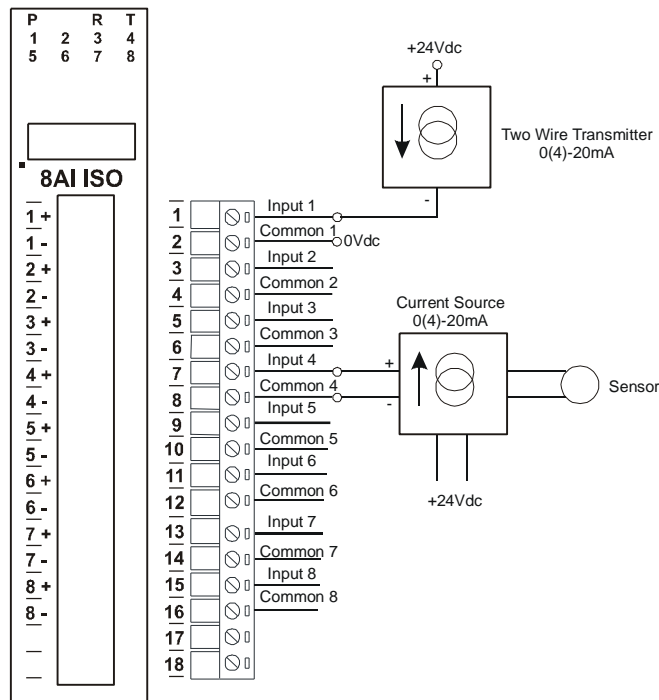

The following diagram shows how the analog inputs are connected to a 0(2)-10Vdc source. All of the common terminals are isolated from each other.

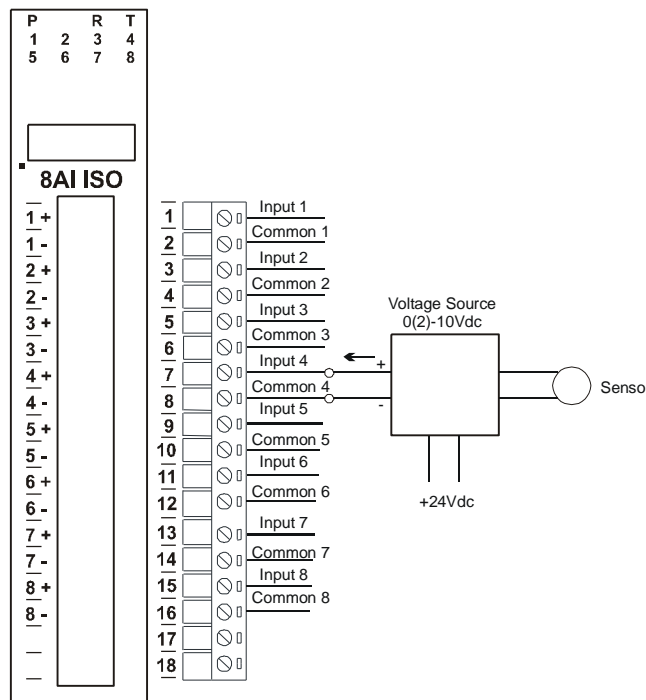

The following diagram shows the wiring for the power and RS485 communications.

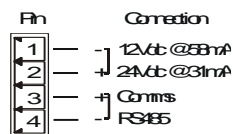

3.11.5 Switch Settings

SWITCH	FUNCTION	DESCRIPTION
1	NODE ID +1	Node ID's from 0 to 127 are set up using switches 1 to 7
2	NODE ID +2	"
3	NODE ID +4	"
4	NODE ID +8	"
5	NODE ID +16	"
6	NODE ID +32	"
7	NODE ID +64	"
8	OFFSET	When switched ON the inputs are scaled to accept a 2V or 4mA offset.
9	OUT OF RANGE	An out of range is given when the input is too negative or too positive. When switched off the analog value will be loaded with -32767 when out of range. When switched on the analog value will be loaded with 32768 when out of range.
10	BAUD RATE	Selects 9600 (off) or Programmed Baud Rate (on)

3.11.6 PM8AI ISO Data Registers (8AI/I TYPE = 107/8AI/V TYPE = 108)

Modbus Address	Register Name	Low Limit	High Limit	Access	Description
30001	S/W Version / Module Type	N/A	N/A	R	High Byte = Software Version Low Byte = 107(PM8AI/I) or 108(PM8AI/V)
30002	Analog Input 1	0	65535	R	Analog Input lower 16 Bits
30003	Analog Input 2	0	65535	R	"
30004	Analog Input 3	0	65535	R	"
30005	Analog Input 4	0	65535	R	"
30006	Analog Input 5	0	65535	R	"
30007	Analog Input 6	0	65535	R	"
30008	Analog Input 7	0	65535	R	"
30009	Analog Input 8	0	65535	R	"
30010	Input Status	0	65535	R	bit2 = 0(open circuit or < 2), bit2 = 1(over range) bit1 = 0(OK),bit1 = 1(error)
30011	Input Alarm Status	0	255	R	bit1 = 0(OK),bit1 = 1(input < 2mA) (version 8 onwards)
30100	DIP Switch	0	65535	R	Status of DIP Switch on Front Panel
40101	Input Type	1	7	R/W	See specification table.
40121	Baud Rate	2400	18750	R/W	2400, 4800, 9600, 19200, 38400, 57600, 115200, 187500
40122	Parity	0	2	R/W	0 = none, 1 = even, 2 = odd
40123	Stop Bits	1	2	R/W	1 = 1 stop bit, 2 = 2 stop bits
40124	Reply Delay	0	255	R/W	0 = Disable, >0 = Enable. (x10ms)

3.11.6.1 Analog Input Registers.

The analog inputs are read as a 16 bit value in the registers as follows:

MSB				PM8AI ANALOG INPUTS												LSB		ADDRESS
15	14	13	12	11	10	9	8	7	6	5	4	3	2	1	0			
32768	16384	8192	4096	2048	1024	512	256	128	64	32	16	8	4	2	1	300XX		
X	X	X	X	X	X	X	X	X	X	X	X	X	X	X	X	X		

Analog Input: 16 Bit Value (0 - 65535)

3.11.6.2 Analog Input Status.

There are two status bits associated with each analog input. These bits are used to indicate if the input is zero or open circuit, in the working range 0-4095, or over range. If the input is open circuit or over range, then the error bit will be set. When the error bit is set, the range bit is zero if the input is open circuit and set if the input is over range, ie:

<u>Bit 1- Error</u>	<u>Bit 2-Range</u>	<u>Condition</u>	<u>Status LED</u>
0	don't care	Input working OK.	(LED OFF)
1	0	Input Open circuit or zero.	(LED ON)
1	1	Input Over range.	(LED FLASH)

The analog input status can be read in a single register as follows:

MSB				PM8AI ANALOG INPUT STATUS												LSB		ADDRESS
15	14	13	12	11	10	9	8	7	6	5	4	3	2	1	0			
32768	16384	8192	4096	2048	1024	512	256	128	64	32	16	8	4	2	1	30010		

3.11.6.3 Analog Input Alarm Status.

There is one alarm status bit associated with each analog input. The alarm bits are used to indicate if the 4-20mA current loop is broken and the bit will be set if the loop current is less than 2mA.

For the voltage module there is one alarm status bit associated with each voltage input. The alarm bits are used to indicate if the 2-10V voltage input is broken and the bit will be set if the input voltage is less than 1V.

The analog input alarm status can be read in a single register as follows:

MSB		PM8AI ANALOG INPUT ALARM STATUS													LSB		ADDRESS
15	14	13	12	11	10	9	8	7	6	5	4	3	2	1	0		
32768	16384	8192	4096	2048	1024	512	256	128	64	32	16	8	4	2	1	30011	

IP1 Alarm
 IP2 Alarm
 IP3 Alarm
 IP4 Alarm
 IP5 Alarm
 IP6 Alarm
 IP7 Alarm
 IP8 Alarm

3.12 PM8TC - THERMOCOUPLE INPUTS

3.12.1 Description

The PM8TC module is a 8 thermocouple input module. The module uses differential inputs to reduce effects of electrical noise and mains pickup. The thermocouple inputs are isolated from the logic. If inter channel isolation is required then the PM8TCISO should be used.

The thermocouple voltage is read by the module circuitry, linearised and converted to degrees Centigrade. No ranging is required as the module covers the full range as indicated in the table of TC types. The value that is read from the Modbus register is the actual temperature in degrees centigrade to 0.1°C resolution. ie: a value of 3451 corresponds to a temperature of 345.1°C.

The thermocouple type is setup by writing a value to the TC Type register. The value is obtained from the table below. For example to select type K thermocouples, the value "2" must be written to the TC Type register. All 8 thermocouple inputs adopt the same TC type.

The DIP switch 9 is used to select upscale or downscale burnout. A value of 32768 is used to indicate upscale burnout and a value of -32767 is used to indicate downscale burnout.

The module has built in Cold Junction Compensation. Use must be made of the correct thermocouple extension wire to avoid reading errors.

The thermocouple module can also be configured for a 0 - 50mV input range. The TC Type register must be set to 9 for this option. The value in the register which is read back over the network is 0 - 50,000.

Note: As there is no inter-channel isolation, isolated thermocouples must be used in order to prevent ground loops and reading errors.



3.12.2 Technical Specification of PM8TC

Power Supply	Logic Supply Voltage	12 -24 Vdc		
	Logic Supply Current	62mA @ 12V / 33mA @ 24V		
TC Inputs	Input Points	8		
	Resolution	0.1°C		
	Drift	100ppm/°C Typ.		
	Isolation	1500Vrms between field and logic		
TC Type	Number	Type	Range	Accuracy
	1	J	-150 to 760 °C	0.2°C
	2	K	-200 to 1370 °C	0.3°C
	3	E	-200 to 1000 °C	0.1°C
	4	T	-200 to 400 °C	0.3°C
	5	N	0 to 1300 °C	0.3°C
	6	B	400 to 1820 °C	0.5°C
	7	S	-50 to 1767 °C	0.6°C
	8	R	-50 to 1767 °C	0.7°C
	9	mV	0 to 50mV	0.1%
	10	C	0 to 2315.5 °C	0.7°C
	11	D	0 to 2315.5 °C	0.7°C
	12	G	0 to 2315.5 °C	0.9°C
13	m V	+/- 100mV	0.1%	
Cold Junction	CJC Error	±0.5°C Typ. After 30 Minutes warm up time.		
Temperature	Operating Temperature.	-30°C to + 80°C		
	Storage Temperature	-40°C to + 85°C		
Connectors	Logic Power and Comms.	4 Pin Connector on underside of unit		
	Inputs	18 Way screw connector on front		

3.12.3 Status Indicators

- Power:** Flashes to indicate the CPU is running.
- RS485 Rx:** Flashes to indicate the unit has received a valid Modbus message.
- RS485 Tx:** Flashes to indicate the unit has sent a Modbus message.
- Input Status:** "ON" when the thermocouple is open circuit.
"OFF" when the thermocouple is connected.

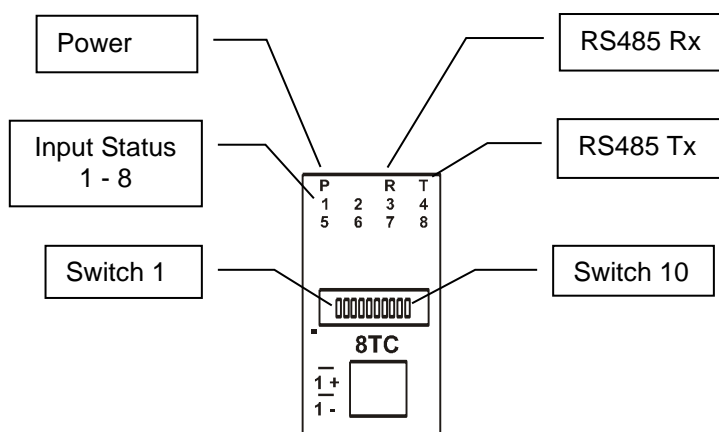

3.12.4 Wiring

The following diagram shows how the inputs are connected to a thermocouple.

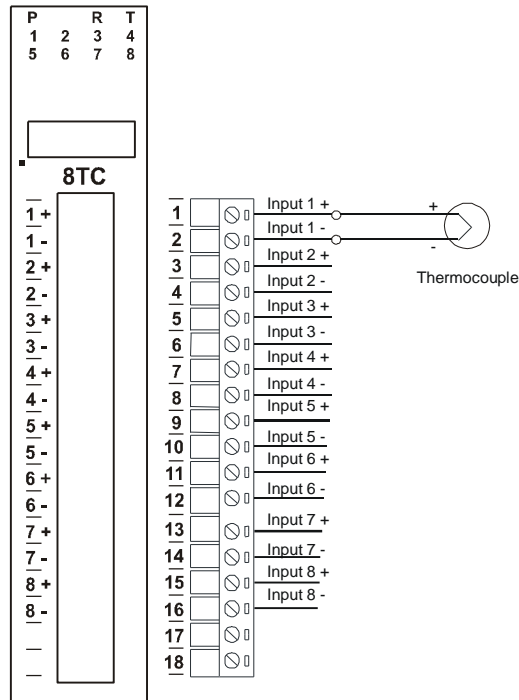

The following diagram shows the wiring for the power and RS485 communications.

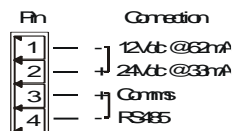

3.12.5 Switch Settings

SWITCH	FUNCTION	DESCRIPTION
1	NODE ID +1	Node ID's from 0 to 127 are set up using switches 1 to 7
2	NODE ID +2	"
3	NODE ID +4	"
4	NODE ID +8	"
5	NODE ID +16	"
6	NODE ID +32	"
7	NODE ID +64	"
8	-	Not used.
9	BREAK	TC break. When switched off the TC value will be loaded with -32767 when the TC is faulty. When switched on the TC value will be loaded with 32768.
10	BAUD RATE	Selects 9600 (off) or Programmed Baud Rate (on)

3.12.6 PM8TC Data Registers (MODULE TYPE = 105)

Modbus Address	Register Name	Low Limit	High Limit	Access	Description
30001	S/W Version / Module Type	N/A	N/A	R	High Byte = Software Version Low Byte = 105
30002	TC Input 1	-xxx.x	yyyy.y	R	Thermocouple Inputs. See table for range.
30003	TC Input 2	-xxx.x	yyyy.y	R	Resolution in 0.1°C.
30004	TC Input 3	-xxx.x	yyyy.y	R	"
30005	TC Input 4	-xxx.x	yyyy.y	R	"
30006	TC Input 5	-xxx.x	yyyy.y	R	"
30007	TC Input 6	-xxx.x	yyyy.y	R	"
30008	TC Input 7	-xxx.x	yyyy.y	R	"
30009	TC Input 8	-xxx.x	yyyy.y	R	"
30010	CJC Temp.	-xxx.x	yyyy.y	R	CJC Temperature in 0.1°C resolution.
30011	Input Status	0	65535	R	bit1 = 0(OK),bit1 = 1(error or open circuit)
30100	DIP Switch	0	65535	R	Status of DIP Switch on Front Panel
40101	TC Type	1	13	R/W	See TC Tables.
40102	Line Frequency	50	60	R/W	Line Frequency
40103	CJC Offset	1	199	R/W	100 = zero offset (0.0)
40104	Units Type	1	2	R/W	1=°C, 2=°F
40121	Baud Rate	2400	18750	R/W	2400, 4800, 9600, 19200, 38400, 57600, 115200, 187500
40122	Parity	0	2	R/W	0 = none, 1 = even, 2 = odd
40123	Stop Bits	1	2	R/W	1 = 1 stop bit, 2 = 2 stop bits
40124	Reply Delay	0	255	R/W	0 = Disable, >0 = Enable. (x10ms)

3.13 PM8TCISO - ISOLATED THERMOCOUPLE INPUTS

3.13.1 Description

The PM8TCISO module is a 8 isolated thermocouple input module. The module uses differential inputs to reduce effects of electrical noise and mains pickup. The thermocouple inputs are isolated from the logic and from each other. This module is operated in an identical way to the PM8TC module and is fully interchangeable.

The thermocouple voltage is read by the module circuitry, linearised and converted to degrees Centigrade. No ranging is required as the module covers the full range as indicated in the TC table. The value that is read from the Modbus register is the actual temperature in degrees centigrade to 0.1°C resolution. ie: a value of 3451 corresponds to a temperature of 345.1°C.

The thermocouple type is setup by writing a value to the TC Type register. The value is obtained from the table below. For example to select type K thermocouples, the value "2" must be written to the TC Type register. All 8 thermocouple inputs adopt the same TC type.

The DIP switch 9 is used to select upscale or downscale burnout. A value of 32768 is used to indicate upscale burnout and a value of -32767 is used to indicate downscale burnout.

The module has built in Cold Junction Compensation. Use must be made of the correct thermocouple extension wire to avoid reading errors.

The thermocouple module can also be configured for a 0 - 50mV input range. The TC Type register must be set to 9 for this option. The value in the register which is read back over the network is 0 - 50,000.



3.13.2 Technical Specification of PM8TC

Power Supply	Logic Supply Voltage	12 -24 Vdc		
	Logic Supply Current	58mA @ 12V / 31mA @ 24V		
TC Inputs	Input Points	8		
	Resolution	0.1°C		
	Drift	100ppm/°C Typ.		
	Isolation	1500Vrms between field and logic 350Vpeak between each TC input		
TC Type	Number	Type	Range	Accuracy
	1	J	-150 to 760 °C	0.2°C
	2	K	-200 to 1370 °C	0.3°C
	3	E	-200 to 1000 °C	0.1°C
	4	T	-200 to 400 °C	0.3°C
	5	N	0 to 1300 °C	0.3°C
	6	B	400 to 1820 °C	0.5°C
	7	S	-50 to 1767 °C	0.6°C
	8	R	-50 to 1767 °C	0.7°C
	9	mV	0 to 50mV	0.1%
	10	C	0 to 2315.5 °C	0.7°C
	11	D	0 to 2315.5 °C	0.7°C
	12	G	0 to 2315.5 °C	0.9°C
13	m V	+/- 100mV	0.1%	
Cold Junction	CJC Error	±0.5°C Typ. After 30 Minutes warm up time.		
Temperature	Operating Temperature.	-30°C to + 80°C		
	Storage Temperature	-40°C to + 85°C		
Connectors	Logic Power and Comms.	4 Pin Connector on underside of unit		
	Inputs	18 Way screw connector on front		

3.13.3 Status Indicators

- Power:** Flashes to indicate the CPU is running.
- RS485 Rx:** Flashes to indicate the unit has received a valid Modbus message.
- RS485 Tx:** Flashes to indicate the unit has sent a Modbus message.
- Input Status:** "ON" when the thermocouple is open circuit.
"OFF" when the thermocouple is connected.

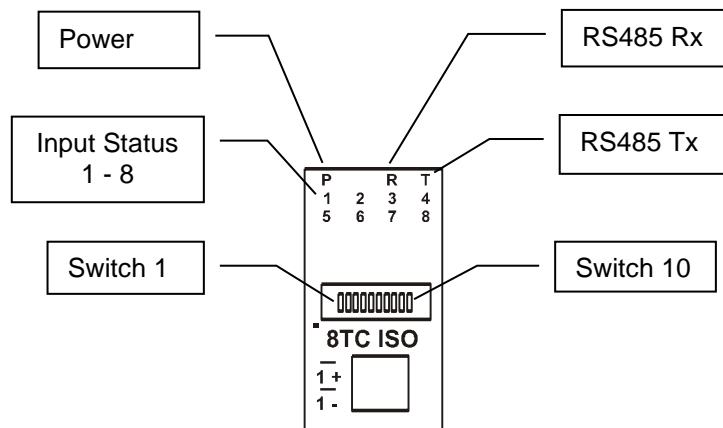

3.13.4 Wiring

The following diagram shows how the inputs are connected to a thermocouple.

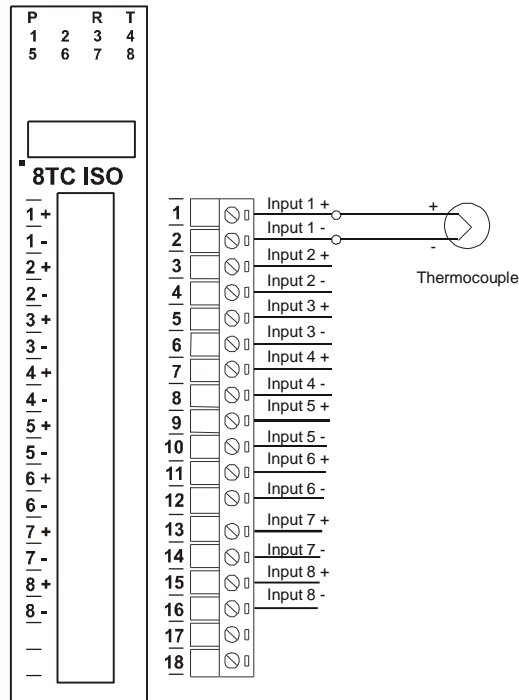

The following diagram shows the wiring for the power and RS485 communications.

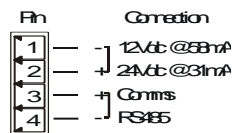

3.13.5 Switch Settings

SWITCH	FUNCTION	DESCRIPTION
1	NODE ID +1	Node ID's from 0 to 127 are set up using switches 1 to 7
2	NODE ID +2	"
3	NODE ID +4	"
4	NODE ID +8	"
5	NODE ID +16	"
6	NODE ID +32	"
7	NODE ID +64	"
8	-	Not used.
9	BREAK	TC break. When switched off the TC value will be loaded with -32767 when the TC is faulty. When switched on the TC value will be loaded with 32768.
10	BAUD RATE	Selects 9600 (off) or Programmed Baud Rate (on)

3.13.6 PM8TCISO Data Registers (MODULE TYPE = 106)

Modbus Address	Register Name	Low Limit	High Limit	Access	Description
30001	S/W Version / Module Type	N/A	N/A	R	High Byte = Software Version Low Byte = 106
30002	TC Input 1	-xxx.x	yyyy.y	R	Thermocouple Inputs. See table for range.
30003	TC Input 2	-xxx.x	yyyy.y	R	Resolution in 0.1°C.
30004	TC Input 3	-xxx.x	yyyy.y	R	"
30005	TC Input 4	-xxx.x	yyyy.y	R	"
30006	TC Input 5	-xxx.x	yyyy.y	R	"
30007	TC Input 6	-xxx.x	yyyy.y	R	"
30008	TC Input 7	-xxx.x	yyyy.y	R	"
30009	TC Input 8	-xxx.x	yyyy.y	R	"
30010	CJC Temp.	-xxx.x	yyyy.y	R	CJC Temperature in 0.1°C resolution.
30011	Input Status	0	65535	R	bit1 = 0(OK),bit1 = 1(error or open circuit)
30100	DIP Switch	0	65535	R	Status of DIP Switch on Front Panel
40101	TC Type	1	13	R/W	See TC Tables.
40102	Line Frequency	50	60	R/W	Line Frequency
40103	CJC Offset	1	199	R/W	100 = zero offset (0.0)
40104	Units Type	1	2	R/W	1=°C, 2=°F
40121	Baud Rate	2400	18750	R/W	2400, 4800, 9600, 19200, 38400, 57600, 115200, 187500
40122	Parity	0	2	R/W	0 = none, 1 = even, 2 = odd
40123	Stop Bits	1	2	R/W	1 = 1 stop bit, 2 = 2 stop bits
40124	Reply Delay	0	255	R/W	0 = Disable, >0 = Enable. (x10ms)

3.13.6.1 TC Input Status.

There are two status bits associated with each TC input. These bits are used to indicate if the input is open circuit. If the input is open circuit, then the error bit will be set. The second bit is not used.

<u>Bit 1- Error</u>	<u>Bit 2-Not Used</u>	<u>Condition</u>	<u>Status LED</u>
0	don't care	Input working OK.	(LED OFF)
1	don't care	Input Open circuit	(LED ON)

The TC input status can be read in a single register as follows:

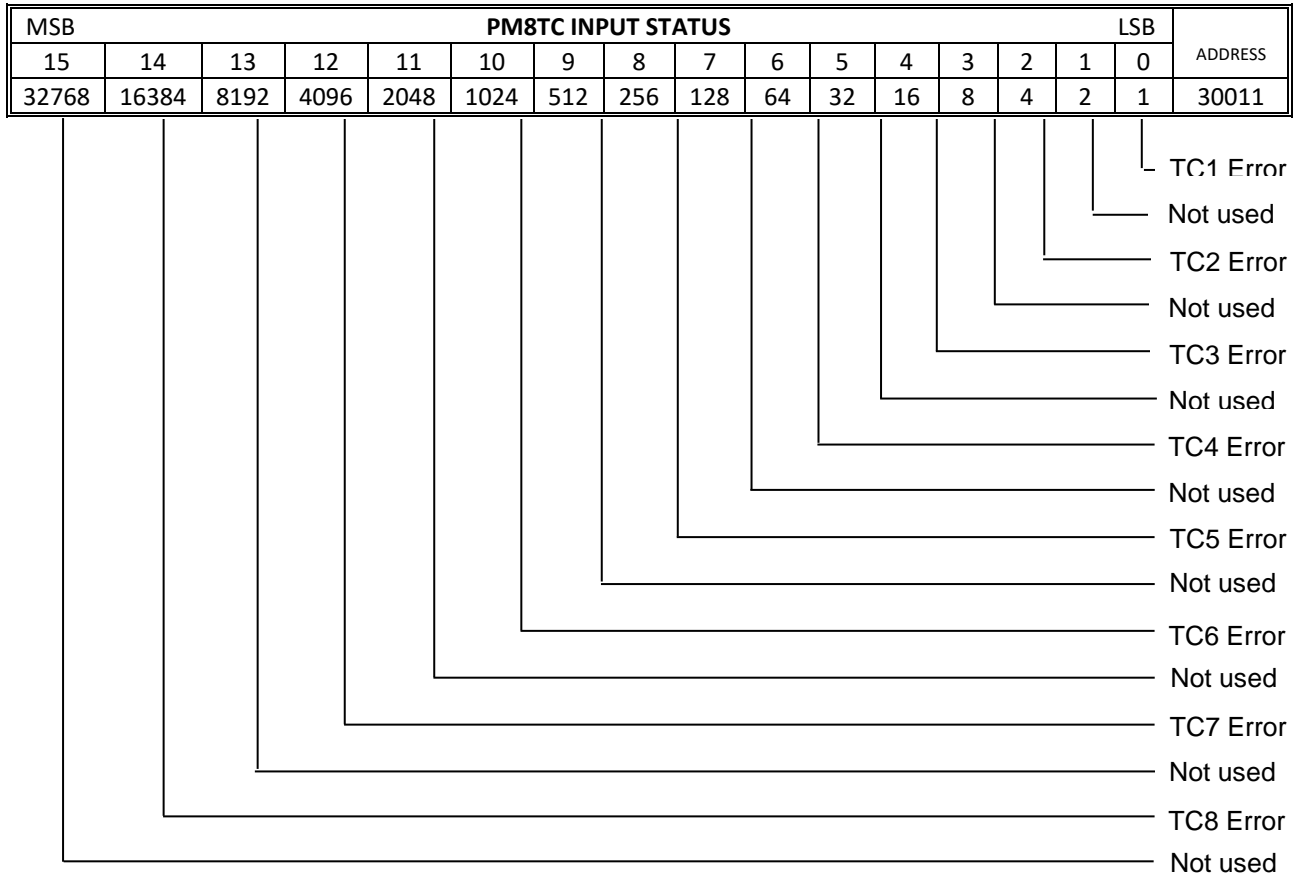

3.14 PM6RTD - RTD INPUTS

3.14.1 Description

The PM6RTD module is a 6 RTD input module. The module can accommodate either 2 or 3 wire RTD sensors. The RTD inputs are isolated from the logic.

The RTD resistance is read by the module circuitry, linearised and converted to degrees Centigrade. No ranging is required as the module covers the full range of the RTD as indicated in the RTD table. The value that is read from the Modbus register is the actual temperature in degrees centigrade to 0.1°C resolution. ie: a value of 3451 corresponds to a temperature of 345.1°C.

The RTD type is setup by writing a value to the RTD Type register. The value is obtained from the table below. For example to select a PT100 RTD, the value "1" must be written to the RTD Type register. All 6 RTD inputs adopt the same RTD type.

The DIP switch 9 is used to select upscale or downscale burnout for break detection. A value of 32768 is used to indicate upscale burnout and a value of -32767 is used to indicate downscale burnout.

Note: As there is no inter-channel isolation, isolated RTD's must be used in order to prevent ground loops and reading errors.



3.14.2 Technical Specification of PM6RTD

Power Supply	Logic Supply Voltage	12 -24 Vdc		
	Logic Supply Current	87mA @ 12V / 45mA @ 24V		
RTD Inputs	Input Points	6		
	RTD Configuration	2 or 3 Wire		
	Resolution	0.1°C		
	Drift	100ppm/°C Typ.		
	Line resistance effect	< 0.1°C balanced		
	Max. line resistance	100ohms		
	Isolation	1500Vrms between field and logic		
RTD Type	Number	Type	Range	Accuracy
	1	PT100	-200 to 850°C	0.3°CIEC 751:1983
	2	Ni120	-80 to 320°C	0.3°C
	3	PT1000	-200 to 850°C	0.3°C
	4	Ni1000-DIN	-200 to 850°C	0.3°C
	5	Ni1000- Landys&Gyr	-200 to 850°C	0.3°C
	6	Ohms	10 - 400 ohms	
	7	Ohms	100-4000ohms	
Temperature	Operating Temperature.	-40°C to + 80°C		
	Storage Temperature	-40°C to + 85°C		
Connectors	Logic Power and Comms.	4 Pin Connector on underside of unit		
	Inputs	18 Way screw connector on front		

3.14.3 Status Indicators

- Power:** Flashes to indicate the CPU is running.
- RS485 Rx:** Flashes to indicate the unit has received a valid Modbus message.
- RS485 Tx:** Flashes to indicate the unit has sent a Modbus message.
- Input Status:** "ON" when the RTD is open circuit.
"OFF" when the RTD is connected.

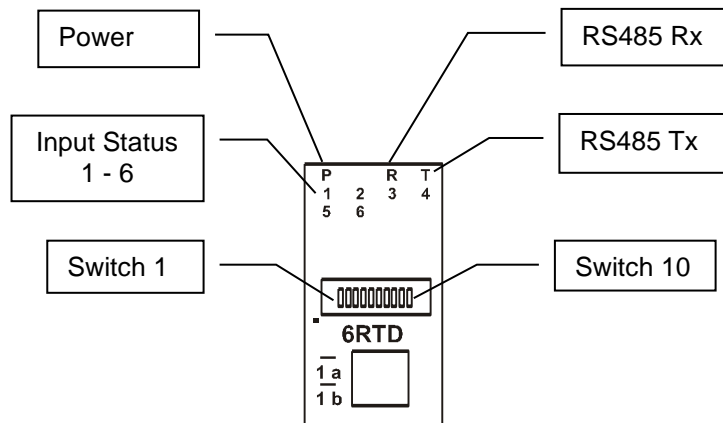

3.14.4 Wiring

The following diagram shows how the inputs are connected to a 2 and 3 wire RTD.

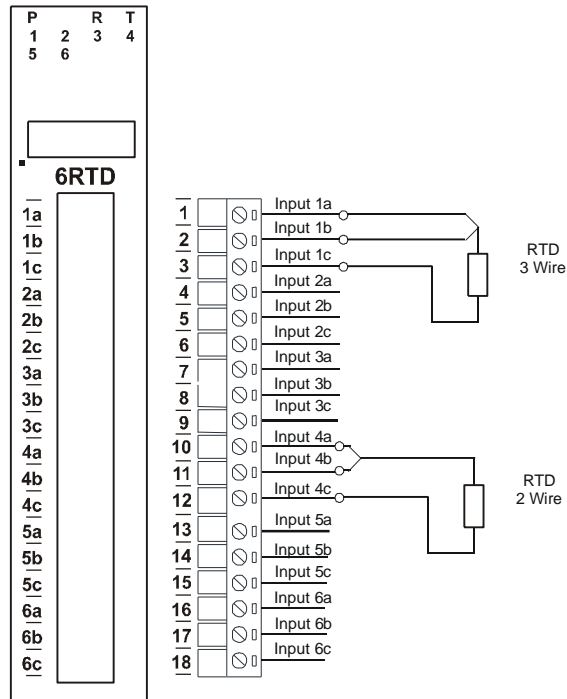

The following diagram shows the wiring for the power and RS485 communications.

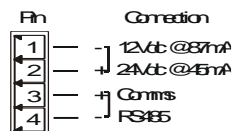

3.14.5 Switch Settings

SWITCH	FUNCTION	DESCRIPTION
1	NODE ID +1	Node ID's from 0 to 127 are set up using switches 1 to 7
2	NODE ID +2	"
3	NODE ID +4	"
4	NODE ID +8	"
5	NODE ID +16	"
6	NODE ID +32	"
7	NODE ID +64	"
8	-	Not used.
9	BREAK	RTD break. When switched off the RTD value will loaded with -32767 when the RTD is faulty. When switched on the RTD value will be loaded with 32768.
10	BAUD RATE	Selects 9600 (off) or Programmed Baud Rate (on)

3.14.6 PM6RTD Data Registers (MODULE TYPE = 109)

Modbus Address	Register Name	Low Limit	High Limit	Access	Description
30001	S/W Version / Module Type	N/A	N/A	R	High Byte = Software Version Low Byte = 109
30002	RTD Input 1	-xxx.x	yyyy.y	R	Thermocouple Inputs. See table for range.
30003	RTD Input 2	-xxx.x	yyyy.y	R	Resolution in 0.1°C.
30004	RTD Input 3	-xxx.x	yyyy.y	R	"
30005	RTD Input 4	-xxx.x	yyyy.y	R	"
30006	RTD Input 5	-xxx.x	yyyy.y	R	"
30007	RTD Input 6	-xxx.x	yyyy.y	R	"
30008	Input Status	0	65535	R	bit1 = 0(OK),bit1 = 1(error or open circuit)
30100	DIP Switch	0	65535	R	Status of DIP Switch on Front Panel
40101	RTD Type	1	7	R/W	See RTD Tables.
40102	Line Frequency	50	60	R/W	Line Frequency
40103	Units Type	1	2	R/W	1=°C, 2=°F
40121	Baud Rate	2400	18750	R/W	2400, 4800, 9600, 19200, 38400, 57600, 115200, 187500
40122	Parity	0	2	R/W	0 = none, 1 = even, 2 = odd
40123	Stop Bits	1	2	R/W	1 = 1 stop bit, 2 = 2 stop bits
40124	Reply Delay	0	255	R/W	0 = Disable, >0 = Enable. (x10ms)

3.14.6.1 RTD Input Status.

There is one status bits associated with each RTD input. These bits are used to indicate if the input is open circuit or over range. If the input is open circuit or over range, then the error bit will be set.

<u>Bit 1- Error</u>	<u>Bit 2-Not Used</u>	<u>Condition</u>	<u>Status LED</u>
0	0	Input working OK.	(LED OFF)
1	0	Open circuit / Over range.	(LED ON)

The analog input status can be read in a single register as follows:

MSB		PM6RTD ANALOG INPUT STATUS												LSB		ADDRESS
15	14	13	12	11	10	9	8	7	6	5	4	3	2	1	0	
32768	16384	8192	4096	2048	1024	512	256	128	64	32	16	8	4	2	1	30008

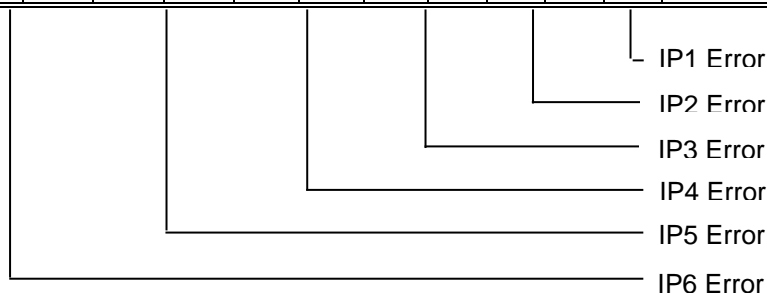

DIGITAL INPUTS:

There are 4 digital inputs on the module. The inputs share a common terminal and can be configured for common positive or common negative.

The inputs have got counters associated with them. The counters operate in three modes.

In **mode 0** all the counters are disabled.

In **mode 1** all counters are 32 bit counters allowing a count value from 0 to 4294967295. The count value can be cleared by writing a zero to the associated registers or preset to any other value using the same method.

In **mode 2** the inputs are connected as up/down counters. Input 1 will increment counter 1 whilst input 2 decrements counter1.

Note: The count values are not battery backed-up and will be lost if power is turned off.

The format of the registers allows the status of the inputs to be read as either single bits or all at once as a single register on the Modbus network.

DIGITAL OUTPUTS:

The module has 2 open collector (NPN) digital outputs. The outputs may be used to drive lamps or external relays when more drive capability is required.

The outputs are written to by the Modbus master device such as a PC or PLC. Each output can be individually switched on or off, or all outputs can be set up at the same time by writing a single number to the output register which represents the status of all outputs.

An output watchdog timer can be configured to switch off all the outputs if there has been no communications with the module for up to 255 seconds. A value of 0 seconds will disable this timer and the outputs will remain in the last programmed state.

3.15.2 Technical Specification of PMDAIO

Power Supply	Logic Supply Voltage	12 -24 Vdc		
	Logic Supply Current	115mA @ 12V / 58mA @ 24V		
	Field Supply Voltage	24 Vdc		
	Field Supply Current	25mA		
RTD Inputs	Input Points	2		
	RTD Configuration	2 or 3 Wire		
	Resolution	0.1°C		
	Drift	100ppm/°C Typ.		
	Line resistance effect	< 0.1°C balanced		
	Max. line resistance	100ohms		
	Isolation	1500Vrms between field and logic		
RTD Type	Number	Type	Range	Accuracy
	1	PT100	-200 to 850°C	0.3°CIEC 751:1983
	2	Ni120	-80 to 320°C	0.3°C
	3	PT1000	-200 to 850°C	0.3°C
	4	Ni1000-DIN	-200 to 850°C	0.3°C
	5	Ni1000-Landys&Gyr	-200 to 850°C	0.3°C
	6	Ohms	10 - 400 ohms	
	7	Ohms	100-4000ohms	
Current Inputs	Input Points	2		
	Input Current	0 - 20 mA		
	Input Resistance	250ohms		
	InputType	Range	Resolution	
	1	0 – 4095	12 bits	
	2	0–20.000mA	1uA	
	3	+/-20.000mA	1uA	
	Drift	100ppm/°C		
	Accuracy	0.2% of span		
Isolation	1000Vrms between field and logic			
Voltage Inputs	Input Points	2		
	Input Voltage	0 - 1 Vdc or 0 – 10 Vdc		
	Input Resistance	190kohms		
	InputType	Range	Resolution	
	4	0 – 4095	12 bits	
	5	0 – 10.000 V	1mV	
	6	+/- 10.000 V	1mV	
	7	0 – 1.0000 V	0.1mV	
	8	+/- 1.0000 V	0.1mV	
	Drift	100ppm/°C		
	Accuracy	0.2% of span		
	Isolation	1000Vrms between field and logic		
	Current Output	Output Points	1	
Output Current		0 - 20 mA		
OutputType		Range	Resolution	
1		0 – 4095	12 bits	
Drift		100ppm/°C		
Accuracy		0.05% of span		
Compliance		1000 ohms max. @ 24Vdc 500 ohms max. @ 12Vdc		
Voltage Output	Output Points	1		

	Output Voltage	0 - 10 V
	OutputType	Range
	2	0 – 4095
	Drift	100ppm/°C
	Accuracy	0.05% of span
	Compliance	2000 ohms min. load
Digital Inputs	Input Points	4
	Input Voltage Range	10 - 26 Vdc
	Input Current per input	4mA@12Vdc / 8mA @24Vdc
Counters	Inputs	1 to 4
	Resolution	32 Bits
	Frequency	1KHz (max)
	Pulse Width	500us (min)
Digital Outputs	Output Points	2
	Maximum Voltage	36 Vdc
	Maximum Current	100 mA per output
	Vceon	1.1V Max.
Isolation	Between field and logic	1500Vrms between field and logic
Temperature	Operating Temperature.	-40°C to + 80°C
	Storage Temperature	-40°C to + 85°C
Connectors	Logic Power and Comms.	4 Pin Connector on underside of unit
	I/O	18 Way screw connector on front

3.15.3 Status Indicators

- Power:** "ON" when module has power.
RS485 Rx: Flashes to indicate the unit has received a valid Modbus message.
RS485 Tx: Flashes to indicate the unit has sent a Modbus message.

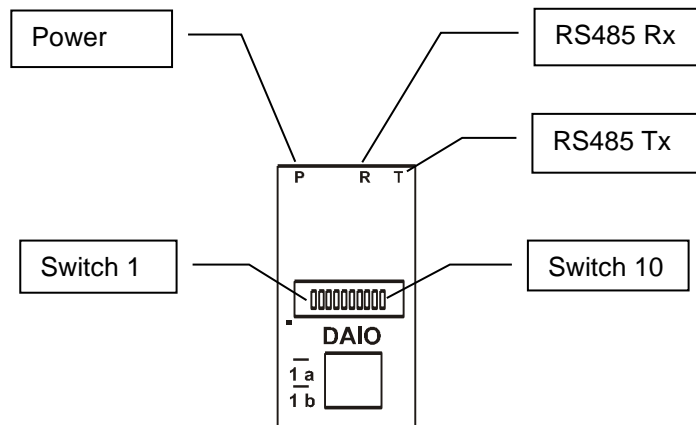

3.15.4 Wiring

The following diagram shows how the inputs and outputs are connected to the DAIO module.

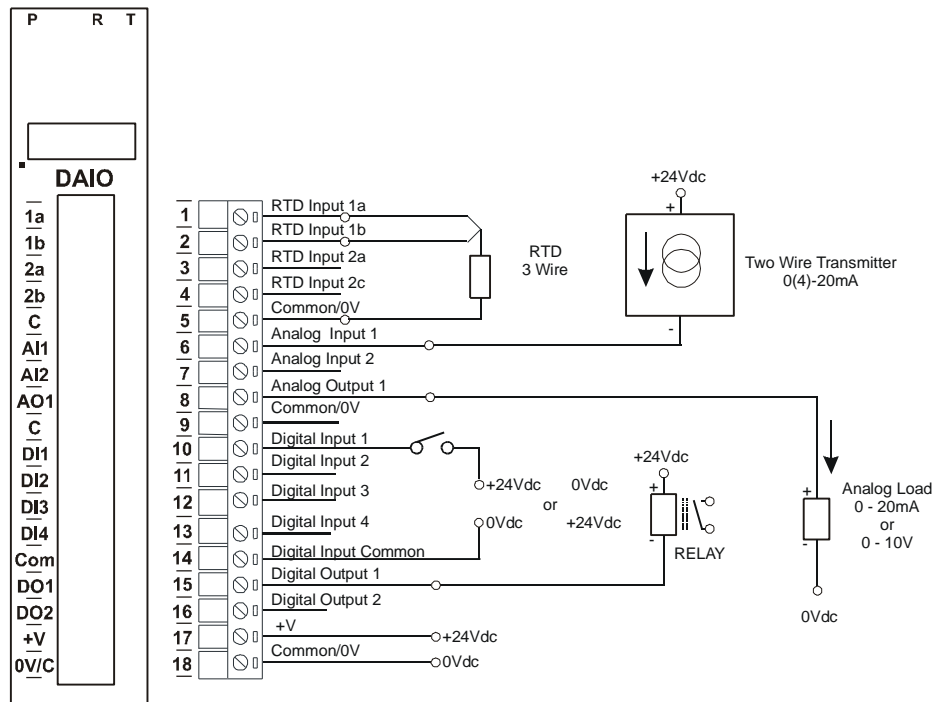

The following diagram shows the wiring for the power and RS485 communications.

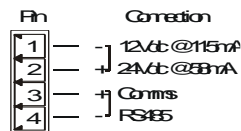

3.15.5 Switch Settings

SWITCH	FUNCTION	DESCRIPTION
1	NODE ID +1	Node ID's from 0 to 127 are set up using switches 1 to 7
2	NODE ID +2	"
3	NODE ID +4	"
4	NODE ID +8	"
5	NODE ID +16	"
6	NODE ID +32	"
7	NODE ID +64	"
8	-	Not used.
9	-	Not used.
10	BAUD RATE	Selects 9600 (off) or Programmed Baud Rate (on)

3.15.6 Setting the jumpers for Current Input and Output.

The Analog inputs can be configured as a current 0(4)-20mA input by placing the jumper on **J7** for A11 and **J8** for A12.

The Analog output can be configured as a current 0(4)-20mA output by placing the jumpers **J4**, **J5** and **J6** on the "I" position as shown below.

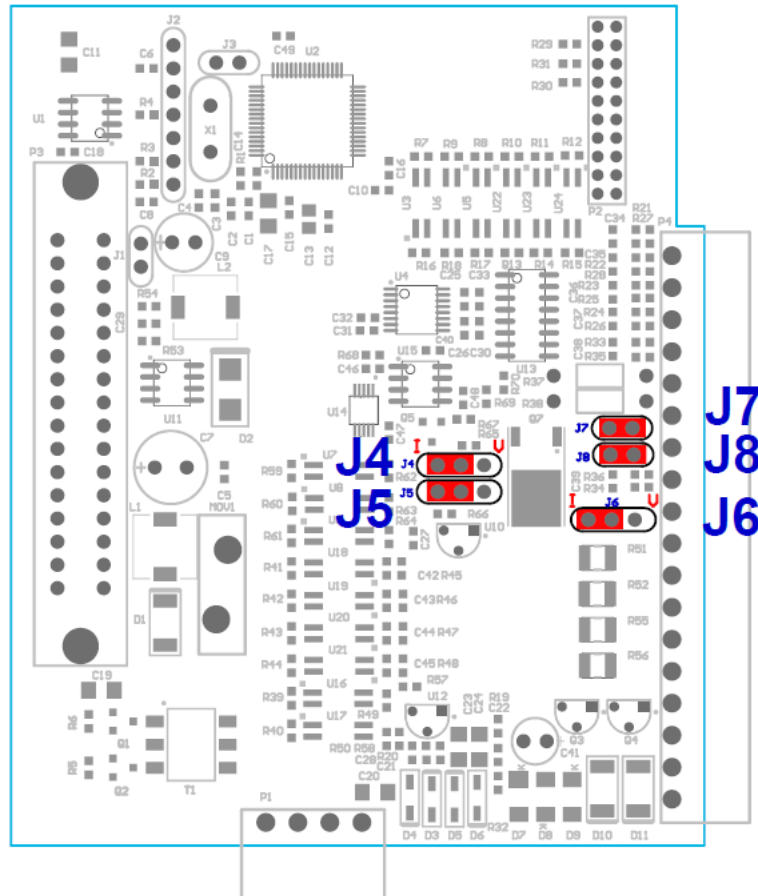

3.15.7 Setting the jumpers for Voltage Input and Output.

The Analog inputs can be configured as a voltage 0-10V input by removing the jumper from **J7** for A11 and **J8** for A12.

The Analog output can be configured as a voltage 0-10V output by placing the jumpers **J4**, **J5** and **J6** on the "V" position as shown below.

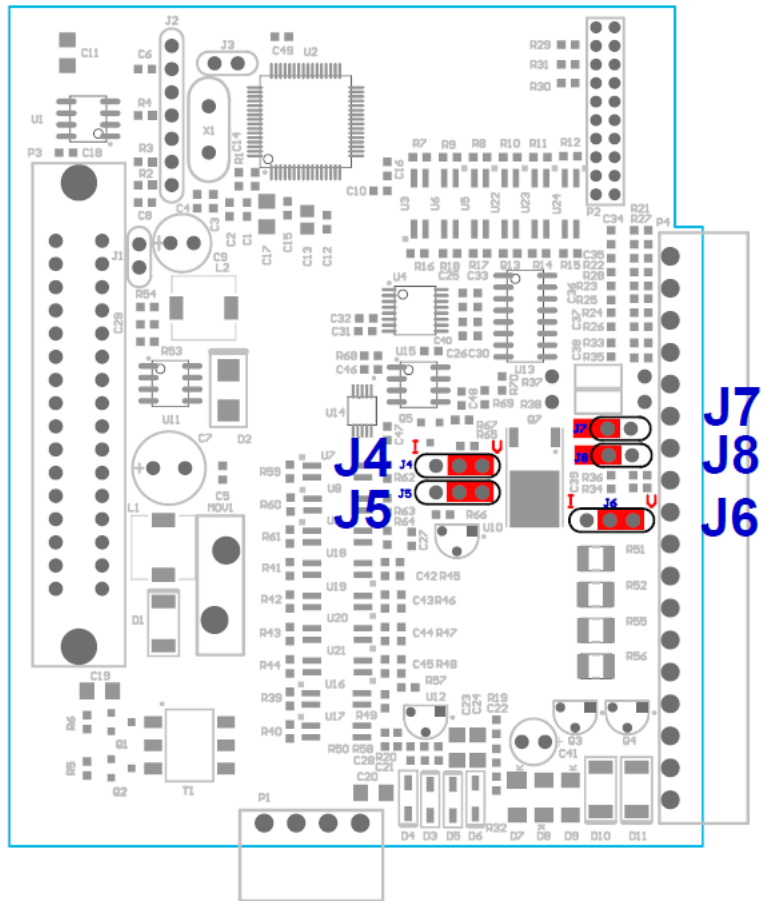

Note: Remember to change the input and output type in the Modbus registers if you change the jumper settings.

3.15.8 PMDAIO Data Registers (MODULE TYPE = 112)

Modbus Address	Register Name	Low Limit	High Limit	Access	Comments
10001	Digital Input 1	0	1	R	Status of Digital Inputs.
10002	Digital Input 2	0	1	R	"
10003	Digital Input 3	0	1	R	"
10004	Digital Input 4	0	1	R	"
00017	Digital Output 1	0	1	R/W	Status of Digital Outputs.
00018	Digital Output 2	0	1	R/W	"
30001	S/W Version / Module Type	N/A	N/A	R	High Byte = Software Version Low Byte = 112
30002	Digital Inputs	N/A	N/A	R	Digital Inputs in lower 8 bits. 8 - 1.
40003	Digital Outputs	N/A	N/A	R/W	Digital Outputs in lower 8 bits. 8 - 1.
40004	RTD Input 1	-xxx.x	yyyy.y	R	RTD Inputs. See table for range.
40005	RTD Input 2	-xxx.x	yyyy.y	R	Resolution in 0.1°C.
40006	Analog Input 1	0	4095	R	Analog Input lower 12 Bits
40007	Analog Input 2	0	4095	R	Analog Input lower 12 Bits
40008	Analog Output 1	0	4095	R/W	Analog Output lower 12 Bits

40009	Counter 1 MSB	0	65535	R/W	Counter MSB and LSB combine to give a 32 bit
40010	Counter 1 LSB	0	65535	R/W	Counter with range 0 to 4294967295.
40011	Counter 2 MSB	0	65535	R/W	“
40012	Counter 2 LSB	0	65535	R/W	“
40013	Counter 3 MSB	0	65535	R/W	“
40014	Counter 3 LSB	0	65535	R/W	“
40015	Counter 4 MSB	0	65535	R/W	“
40016	Counter 4 LSB	0	65535	R/W	“
30100	DIP Switch	0	65535	R	Status of DIP Switch on Front Panel
40101	Watchdog Timer	0	255	R/W	Timer in seconds. 0 = disabled. 1 - 255 = enabled.
40102	Counter Mode	0	2	R/W	0=Disable, 1=Up Counting, 2=Up/Down Count
40103	Input Filter	0	65535	R/W	0 = Disable, >0 = Enable. (x10ms)
40104	RTD 1 Type	1	7	R/W	See RTD Tables.
40105	RTD 2 Type	1	7	R/W	See RTD Tables.
40106	AI 1 Type	1	8	R/W	1 = 0 – 4095 (mA) 2 = 0 – 20.000mA 3 = +/- 20.000mA 4 = 0 – 4095 (V) 5 = 0 – 10.000V 6 = +/- 10.000V 7 = 0 – 1.0000V 8 = +/- 1.0000V
40107	AI 2 Type	1	2	R/W	“
40108	AO Type	1	2	R/W	1 = 0-20mA, 2 = 0-10V
40109	Line Frequency	50	60	R/W	Line Frequency
40110	Units Type	1	2	R/W	1=°C, 2=°F
40121	Baud Rate	2400	18750	R/W	2400, 4800, 9600, 19200, 38400, 57600, 115200, 187500
40122	Parity	0	2	R/W	0 = none, 1 = even, 2 = odd
40123	Stop Bits	1	2	R/W	1 = 1 stop bit, 2 = 2 stop bits
40124	Reply Delay	0	255	R/W	0 = Disable, >0 = Enable. (x10ms)

3.16 PMDAIO2 – DIGITAL + ANALOG INPUTS AND OUTPUTS TYPE 2

3.16.1 Description

The PMDAIO2 module is a multipurpose combination of inputs and outputs. The module can accommodate either current (0-20mA) or voltage (0-10V) inputs, current (0-20mA) outputs, and digital inputs and outputs.

ANALOG INPUTS:

The Analog Inputs (2) can be configured by internal jumpers as either a current input (0-20mA) or a voltage input (0-10V).

An input of 0 - 20mA input current or 0 – 10V input voltage represents an output value of 0 - 4095 (12 bits) in the corresponding Modbus register.

ANALOG OUTPUTS:

The analog outputs are current outputs (0-20mA)

The resolution is 12 bits, so writing a value to the Modbus register for each output of 0 - 4095 would give an output current of 0 - 20mA. A value of $819 \pm 1\text{LSB}$ will give a current output of 4mA.

DIGITAL INPUTS:

There are 4 digital inputs on the module. The inputs share a common terminal and can be configured for common positive or common negative. The inputs have got counters associated with them. The counters operate in three modes.

In **mode 0** all the counters are disabled.

In **mode 1** all counters are 32 bit counters allowing a count value from 0 to 4294967295. The count value can be cleared by writing a zero to the associated registers or preset to any other value using the same method.

In **mode 2** the inputs are connected as up/down counters. Input 1 will increment counter 1 whilst input 2 decrements counter1.

Note: The count values are not battery backed-up and will be lost if power is turned off.

The format of the registers allows the status of the inputs to be read as either single bits or all at once as a single register on the Modbus network.

DIGITAL OUTPUTS:

The module has 4 open collector (NPN) digital outputs. The outputs may be used to drive lamps or external relays when more drive capability is required.

The outputs are written to by the Modbus master device such as a PC or PLC. Each output can be individually switched on or off, or all outputs can be set up at the same time by writing a single number to the output register which represents the status of all outputs.



An output watchdog timer can be configured to switch off all the outputs if there has been no communications with the module for up to 255 seconds. A value of 0 seconds will disable this timer and the outputs will remain in the last programmed state.

3.16.2 Technical Specification of PMDAIO2

Power Supply	Logic Supply Voltage	12 -24 Vdc	
	Logic Supply Current	95mA @ 12V / 48mA @ 24V	
	Field Supply Voltage	24 Vdc	
	Field Supply Current	45mA	
Current Inputs	Input Points	2	
	Input Current	0 - 20 mA	
	Input Resistance	250ohms	
	InputType	Range	Resolution
	1	0 – 4095	12 bits
	2	0–20.000mA	1uA
	3	+/-20.000mA	1uA
	Drift	100ppm/°C	
	Accuracy	0.2% of span	
Isolation	1000Vrms between field and logic		
Voltage Inputs	Input Points	2	
	Input Voltage	0 - 1 Vdc or 0 – 10 Vdc	
	Input Resistance	190kohms	
	InputType	Range	Resolution
	4	0 – 4095	12 bits
	5	0 – 10.000 V	1mV
	6	+/- 10.000 V	1mV
	7	0 – 1.0000 V	0.1mV
	8	+/- 1.0000 V	0.1mV
	Drift	100ppm/°C	
Accuracy	0.2% of span		
Isolation	1000Vrms between field and logic		
Current Outputs	Output Points	2	
	Output Current	0 - 20 mA	
	OutputType	Range	Resolution
	1	0 – 4095	12 bits
	Drift	100ppm/°C	
	Accuracy	0.05% of span	
Compliance	1000 ohms max. @ 24Vdc 500 ohms max. @ 12Vdc		
Digital Inputs	Input Points	4	
	Input Voltage Range	10 - 26 Vdc	
	Input Current per input	4mA@12Vdc / 8mA @24Vdc	
Counters	Inputs	1 to 4	
	Resolution	32 Bits	
	Frequency	1KHz (max)	
	Pulse Width	500us (min)	
Digital Outputs	Output Points	4	
	Maximum Voltage	36 Vdc	
	Maximum Current	100 mA per output	
	Vceon	1.1V Max.	
Isolation	Between field and logic	1500Vrms between field and logic	
Temperature	Operating Temperature.	-40°C to + 80°C	
	Storage Temperature	-40°C to + 85°C	
Connectors	Logic Power and Comms.	4 Pin Connector on underside of unit	
	I/O	18 Way screw connector on front	

3.16.3 Status Indicators

Power:	“ON” when module has power.
RS485 Rx:	Flashes to indicate the unit has received a valid Modbus message.
RS485 Tx:	Flashes to indicate the unit has sent a Modbus message.
Digital I/P Status:	“OFF” when the input is off “ON” when the input is on.
Digital O/P Status:	“OFF” when the output is off “ON” when the output is on.
Analog I/P Status:	“ON” when the input is zero. “OFF” when the input is greater than zero and less than 4095. “Flashing” when the input is over range, greater or equal to 4095.
Analog O/P Status:	“ON” when the input is zero. “OFF” when the input is greater than zero and less than 4095. “Flashing” when the input is over range, greater or equal to 4095.

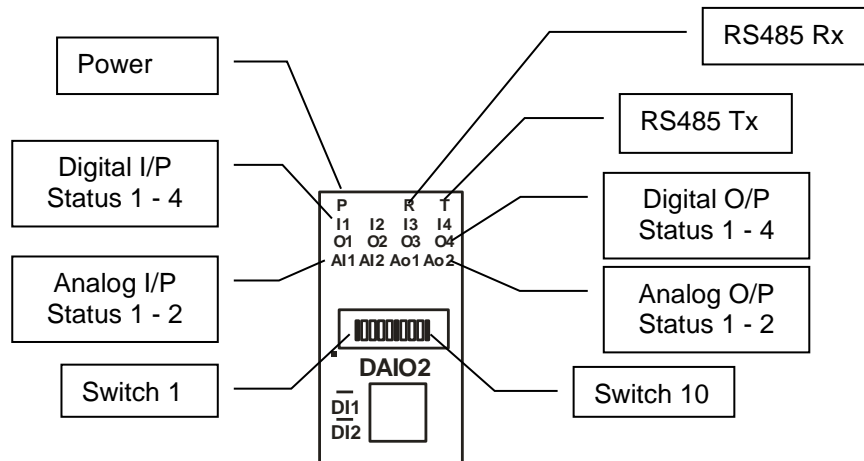

3.16.4 Wiring

The following diagram shows how the inputs and outputs are connected to the DAIO2 module.

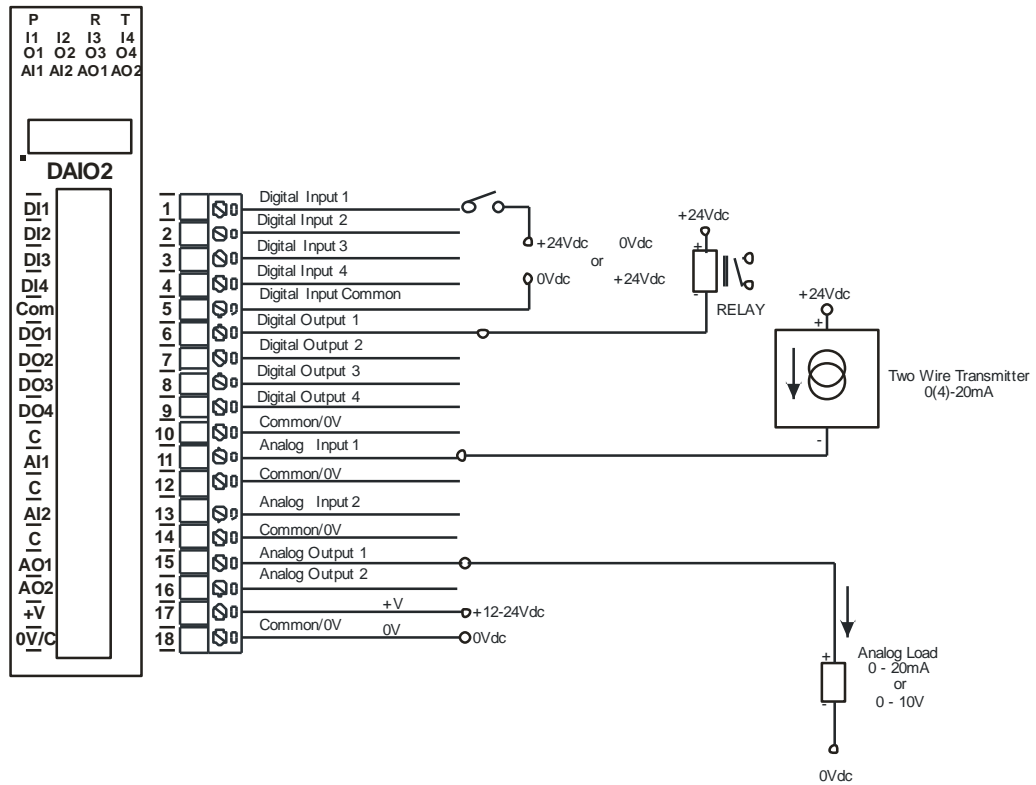

The following diagram shows the wiring for the power and RS485 communications.

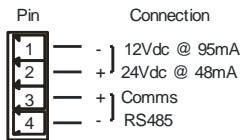

3.16.5 Switch Settings

SWITCH	FUNCTION	DESCRIPTION
1	NODE ID +1	Node ID's from 0 to 127 are set up using switches 1 to 7
2	NODE ID +2	"
3	NODE ID +4	"
4	NODE ID +8	"
5	NODE ID +16	"
6	NODE ID +32	"
7	NODE ID +64	"
8	-	Not used.
9	MODE	Selects Master or Slave Mode. Master mode is used when the module is connected to another PMDAIO2 module. Slave mode is used when the module is to be polled either by the I/O Mapper or by a PC.
10	BAUD RATE	Selects 9600 (off) or Programmed Baud Rate (on)

3.16.6 Setting the jumpers for Current Input.

The Analog inputs can be configured as a current 0(4)-20mA input by placing the jumper on **J6** for AI1 and **J7** for AI2.

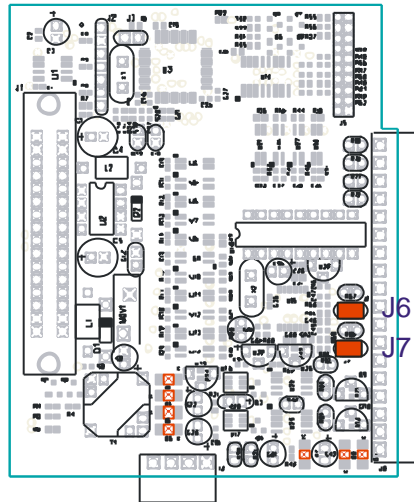

3.16.7 Setting the jumpers for Voltage Input.

The Analog inputs can be configured as a voltage 0-10V input by removing the jumper from **J6** for AI1 and **J7** for AI2.

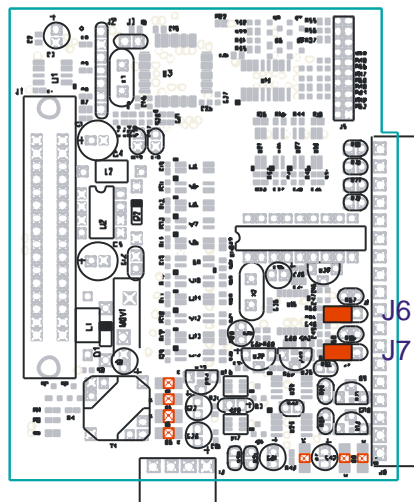

Note: Remember to change the input type in the Modbus registers if you change the jumper settings.

3.16.8 PMDAIO2 Data Registers (MODULE TYPE = 119)

Modbus Address	Register Name	Low Limit	High Limit	Access	Comments
10001	Digital Input 1	0	1	R	Status of Digital Inputs.
10002	Digital Input 2	0	1	R	"
10003	Digital Input 3	0	1	R	"
10004	Digital Input 4	0	1	R	"
00017	Digital Output 1	0	1	R/W	Status of Digital Outputs.
00018	Digital Output 2	0	1	R/W	"
00019	Digital Output 3	0	1	R/W	"
00020	Digital Output 4	0	1	R/W	"
30001	S/W Version / Module Type	N/A	N/A	R	High Byte = Software Version Low Byte = 119
30002	Digital Inputs	N/A	N/A	R	Digital Inputs in lower 8 bits. 4 - 1.
40003	Digital Outputs	N/A	N/A	R/W	Digital Outputs in lower 8 bits. 4 - 1.
30004	Analog Input 1	0	4095	R	Analog Input lower 12 Bits
30005	Analog Input 2	0	4095	R	Analog Input lower 12 Bits
40006	Analog Output 1	0	4095	R/W	Analog Output lower 12 Bits
40007	Analog Output 2	0	4095	R/W	Analog Output lower 12 Bits
40008	Counter 1 MSB	0	65535	R/W	Counter MSB and LSB combine to give a 32bit counter with range 0 to 4294967295.
40009	Counter 1 LSB	0	65535	R/W	"
40010	Counter 2 MSB	0	65535	R/W	"
40011	Counter 2 LSB	0	65535	R/W	"
40012	Counter 3 MSB	0	65535	R/W	"
40013	Counter 3 LSB	0	65535	R/W	"
40014	Counter 4 MSB	0	65535	R/W	"
40015	Counter 4 LSB	0	65535	R/W	"
30016	Analog Input Status	0	65535	R	bit2 = 0(open circuit or < 2), bit2 = 1(over range) bit1 = 0(OK),bit1 = 1(error)
30017	Analog Output Status	0	65535	R	bit2 = 0(0), bit2 = 1(4095) bit1 = 0(OK),bit1 = 1(error)
30100	DIP Switch	0	65535	R	Status of DIP Switch on Front Panel
40101	Watchdog Timer	0	255	R/W	Timer in seconds. 0 = disabled. 1 - 255 = enabled.
40102	Counter Mode	0	2	R/W	0=Disable, 1=Up Counting, 2=Up/Down Count
40103	Input Filter	0	65535	R/W	0 = Disable, >0 = Enable. (x10ms)
40104	AI 1 Type	1	8	R/W	1 = 0 – 4095 (mA) 2 = 0 – 20.000mA 3 = +/- 20.000mA 4 = 0 – 4095 (V) 5 = 0 – 10.000V 6 = +/- 10.000V 7 = 0 – 1.0000V 8 = +/- 1.0000V
40105	AI 2 Type	1	8	R/W	"

40106	Line Frequency	50	60	R/W	Line Frequency (Hz)
40107	Master Timeout	0	65535	R/W	Modbus Master Timeout (X10ms)
40108	Master Poll Rate	0	65535	R/W	Modbus Master Poll Rate (X10ms)
40121	Baud Rate	2400	18750	R/W	2400, 4800, 9600, 19200, 38400, 57600, 115200, 187500
40122	Parity	0	2	R/W	0 = none, 1 = even, 2 = odd
40123	Stop Bits	1	2	R/W	1 = 1 stop bit, 2 = 2 stop bits
40124	Reply Delay	0	255	R/W	0 = Disable, >0 = Enable. (x10ms)

3.16.8.1 Digital Input Register.

The digital inputs can be read in a single register as follows:

MSB		PMDAIO2 DIGITAL INPUTS												LSB		ADDRESS
15	14	13	12	11	10	9	8	7	6	5	4	3	2	1	0	
32768	16384	8192	4096	2048	1024	512	256	128	64	32	16	8	4	2	1	30002
0	0	0	0	0	0	0	0	0	0	0	0	0	4	3	2	1

Digital Input Number

3.16.8.2 Digital Output Register.

The digital outputs can be read/written in a single register as follows:

MSB		PMDAIO2 DIGITAL OUTPUTS												LSB		ADDRESS
15	14	13	12	11	10	9	8	7	6	5	4	3	2	1	0	
32768	16384	8192	4096	2048	1024	512	256	128	64	32	16	8	4	2	1	40003
0	0	0	0	0	0	0	0	0	0	0	0	0	4	3	2	1

Digital Output Number

3.16.8.3 Counter Registers.

The counters are stored a two 16 bit registers. The first register is the High Register and the second register is the Low Register. To get the actual 32 bit count value the registers must be combined as follows:

Counter High Value = Register 40008.

Counter Low Value = Register 40009.

Counter Value = (Counter High Value X 65536) + Counter Low Value.

3.16.8.4 Output Watchdog Timer.

The watchdog timer is used to switch off all of the outputs in the event of a communications failure. When set to zero (register 40101) the watchdog timer is disabled.

3.16.8.5 Analog Input Registers.

The analog inputs are read as a 12 bit value in the registers as follows:

MSB				PMDAIO2 ANALOG INPUTS												LSB			ADDRESS
15	14	13	12	11	10	9	8	7	6	5	4	3	2	1	0				
32768	16384	8192	4096	2048	1024	512	256	128	64	32	16	8	4	2	1	300XX			
0	0	0	0	x	x	x	x	x	x	x	x	x	x	x	x	x			

Analog Input: 12 Bit Value (0 - 4095)

3.16.8.6 Analog Input Status.

There are two status bits associated with each analog input. These bits are used to indicate if the input is zero or open circuit, in the working range 0-4095, or over range. If the input is open circuit or over range, then the error bit will be set. When the error bit is set, the range bit is zero if the input is open circuit and set if the input is over range, ie:

<u>Bit 1- Error</u>	<u>Bit 2-Range</u>	<u>Condition</u>	<u>Status LED</u>
0	don't care	Input working OK.	(LED OFF)
1	0	Input Open circuit or zero.	(LED ON)
1	1	Input Over range.	(LED FLASH)

The analog input status can be read in a single register as follows:

MSB				PMDAIO2 ANALOG INPUT STATUS												LSB			ADDRESS
15	14	13	12	11	10	9	8	7	6	5	4	3	2	1	0				
32768	16384	8192	4096	2048	1024	512	256	128	64	32	16	8	4	2	1	30016			

IP1 Error
IP1 Range
IP2 Error
IP2 Range

3.16.9 Modbus Master Setup.

The module is configured as a Modbus master when switch 9 is on. The PMDAIO2 reads digital inputs from a second PMDAIO2 module and writes the information to the outputs. The PMDAIO2 also writes digital inputs to the second PMDAIO2 module. The same applies to the analog I/O. This results in data being transferred on both directions between the two PMDAIO2 modules. The two modules must have the same network ID and these must be the only modules on the network.

3.16.9.1 Modbus Master Poll Rate.

The rate at which the PMDAIO2 polls the second PMDAIO2 is configured using this register (40108). In some applications where a modem or radio is used in the RS485 network, it may be necessary to slow down the polling of the PMDAIO2 due to turn around delays in the equipment.

3.16.9.2 Modbus Master Timeout.

The PMDAIO2 polls the second PMDAIO2 to get the input data. If there is a problem and the message is corrupted or gets lost, then the PMDAIO2 communications routine will timeout and try again. This parameter should be set to a larger value than the poll rate value.

3.17 PM8AO - ANALOG OUTPUTS

3.17.1 Description

The PM8AO is an 8 channel current output module. Each channel can be set to output a current in the range 0 - 20mA. The outputs are isolated from the logic and share a common negative terminal.

The resolution is 12 bits, so writing a value to the Modbus register for each output of 0 - 4095 would give an output current of 0 - 20mA. A value of $819 \pm 1\text{LSB}$ will give a current output of 4mA.

The module may be used as either a slave or master on the Modbus network. When used with a PC or PLC the module will be configured as a slave. When used with a PM8AI module in a point-to-point configuration, the DIP switch 9 must be turned on to set the module up as a master. In this mode the PM8AO module will automatically read the information from the PM8AI module and write the input status to the outputs.



When used as a slave module, the outputs are written to by the Modbus master device such as a PC or PLC.

3.17.2 Technical Specification of PM8AO

Power Supply	Logic Supply Voltage	12 -24 Vdc
	Logic Supply Current	32mA @ 12V / 18mA @ 24V
	Field Supply Voltage	24 Vdc
	Field Supply Current	175mA
Current Output	Output Points	8
	Output Current	0(4) - 20 mA
	Resolution	12 bits
	Drift	100ppm/°C
	Accuracy	0.05% of span
	Compliance	1000 ohms max. @ 24Vdc 500 ohms max. @ 12Vdc
Isolation	Between field and logic	1500Vrms between field and logic
Temperature	Operating Temperature.	-40°C to + 80°C
	Storage Temperature	-40°C to + 85°C
Connectors	Logic Power and Comms.	4 Pin Connector on underside of unit
	Inputs	18 Way screw connector on front

3.17.3 Status Indicators

- Power:** Flashes to indicate the CPU is running.
- RS485 Rx:** Flashes to indicate the unit has received a valid Modbus message.
- RS485 Tx:** Flashes to indicate the unit has sent a Modbus message.
- Output Status:** "ON" when the output is zero.
"OFF" when the output is between zero and full scale.
"Flashing" when the output is at full scale.

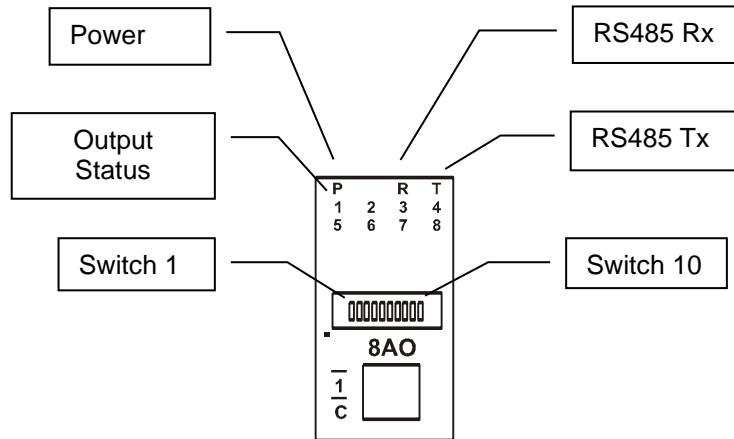

3.17.4 Wiring

The following diagram shows how the analog outputs are connected to a load.

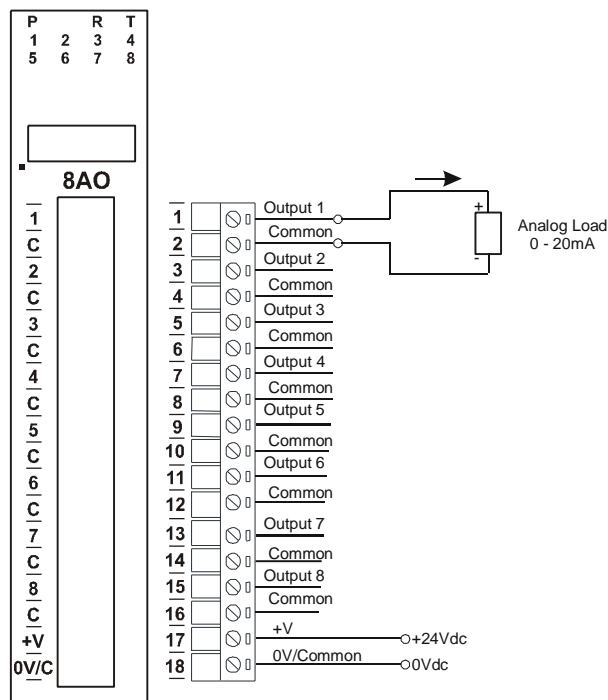

The following diagram shows the wiring for the power and RS485 communications.

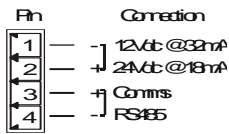

3.17.5 Switch Settings

<u>SWITCH</u>	<u>FUNCTION</u>	<u>DESCRIPTION</u>
1	NODE ID +1	Node ID's from 0 to 127 are set up using switches 1 to 7
2	NODE ID +2	"
3	NODE ID +4	"
4	NODE ID +8	"
5	NODE ID +16	"
6	NODE ID +32	"
7	NODE ID +64	"
8	OFFSET	When switched ON the outputs are scaled to accept a 4mA offset .
9	MODE	Selects Master or Slave Mode. Master mode is used when the module is connected to a single Analog input module. Slave mode is used when the module is to be polled either by the I/O Mapper or by a PC.
10	BAUD RATE	Selects 9600 (off) or Programmed Baud Rate (on)

3.17.6 PM8AO Data Registers (MODULE TYPE = 110)

Modbus Address	Register Name	Low Limit	High Limit	Access	Comments
30001	S/W Version / Module Type	N/A	N/A	R	High Byte = Software Version Low Byte = 110
40002	Current Output 1	0	4095	R/W	Current Outputs. 0 - 4095 = 0(4) - 20mA.
40003	Current Output 2	0	4095	R/W	"
40004	Current Output 3	0	4095	R/W	"
40005	Current Output 4	0	4095	R/W	"
40006	Current Output 5	0	4095	R/W	"
40007	Current Output 6	0	4095	R/W	"
40008	Current Output 7	0	4095	R/W	"
40009	Current Output 8	0	4095	R/W	"
40010	Output Status	0	65535	R	bit2 = 0(0), bit2 = 1(4095) bit1 = 0(OK), bit1 = 1(error)
30100	DIP Switch	0	65535	R	Status of DIP Switch on Front Panel
40101	Watchdog Timer	0	255	R/W	Timer in seconds. 0 = disabled. 1 -255 = enabled.
40102	Master Timeout	0	65535	R/W	Modbus Master Timeout (X10ms)
40103	Master Poll Rate	0	65535	R/W	Modbus Master Poll Rate (X10ms)
40121	Baud Rate	2400	18750	R/W	2400, 4800, 9600, 19200, 38400, 57600, 115200, 187500
40122	Parity	0	2	R/W	0 = none, 1 = even, 2 = odd
40123	Stop Bits	1	2	R/W	1 = 1 stop bit, 2 = 2 stop bits
40124	Reply Delay	0	255	R/W	0 = Disable, >0 = Enable. (x10ms)

3.17.7 Modbus Master Setup.

The module is configured as a Modbus master when switch 9 is on. The PM8AO reads digital inputs from a PM8AI/I module and writes the information to the outputs. The two modules must have the same network ID and these must be the only modules on the network.

3.17.7.1 Modbus Master Poll Rate.

The rate at which the PM8AO polls the PM8AI is configured using this register (40103). In some applications where a modem or radio is used in the RS485 network, it may be necessary to slow down the polling of the PM8AI due to turn around delays in the equipment.

3.17.7.2 Modbus Master Timeout.

The PM8AO polls the PM8AI to get the input data. If there is a problem and the message is corrupted or gets lost, then the PM8AO communications routine will timeout and try again. This parameter should be set to a larger value than the poll rate value.

3.18 PM8VO - ANALOG OUTPUTS

3.18.1 Description

The PM8VO is an 8 channel voltage output module. Each channel can be set to output a voltage in the range 0 – 10V. The outputs are isolated from the logic and share a common negative terminal.

The resolution is 12 bits, so writing a value to the Modbus register for each output of 0 - 4095 would give an output current of 0 – 10V. A value of $819 \pm 1\text{LSB}$ will give a current output of 2V.

The module may be used as either a slave or master on the Modbus network. When used with a PC or PLC the module will be configured as a slave. When used with a PM8AI module in a point-to-point configuration, the DIP switch 9 must be turned on to set the module up as a master. In this mode the PM8VO module will automatically read the information from the PM8AI module and write the input status to the outputs.

When used as a slave module, the outputs are written to by the Modbus master device such as a PC or PLC.



3.18.2 Technical Specification of PM8VO

Power Supply	Logic Supply Voltage	12 -24 Vdc
	Logic Supply Current	32mA @ 12V / 18mA @ 24V
	Field Supply Voltage	24 Vdc
	Field Supply Current	85 mA max.
Voltage Output	Output Points	8
	Output Voltage	0(2) - 10 V
	Resolution	12 bits
	Drift	100ppm/°C
	Accuracy	0.05% of span
	Compliance	2000 ohms min. load
Isolation	Between field and logic	1500Vrms between field and logic
Temperature	Operating Temperature.	-40°C to + 80°C
	Storage Temperature	-40°C to + 85°C
Connectors	Logic Power and Comms.	4 Pin Connector on underside of unit
	Outputs	18 Way screw connector on front

3.18.3 Status Indicators

- Power:** Flashes to indicate the CPU is running.
- RS485 Rx:** Flashes to indicate the unit has received a valid Modbus message.
- RS485 Tx:** Flashes to indicate the unit has sent a Modbus message.
- Output Status:** "ON" when the output is zero.
"OFF" when the output is between zero and full scale.
"Flashing" when the output is at full scale.

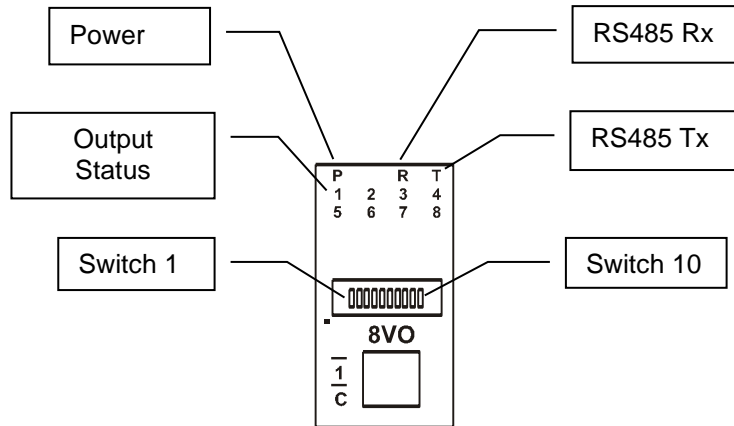

3.18.4 Wiring

The following diagram shows how the analog outputs are connected to a load.

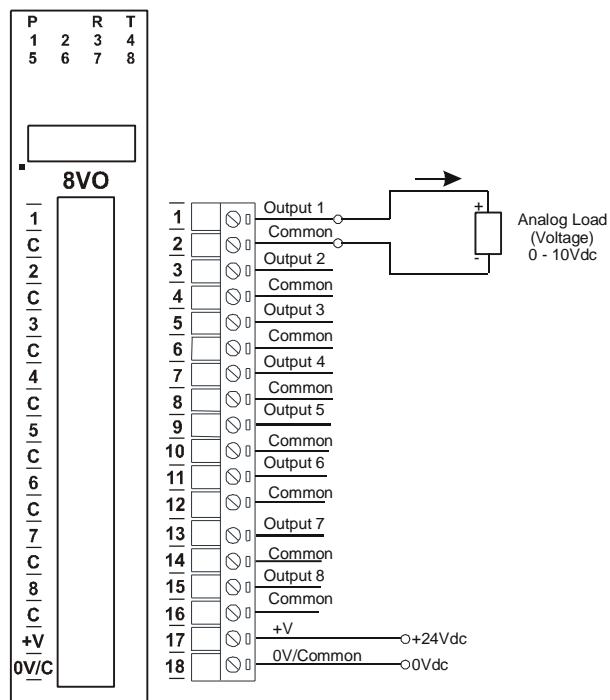

The following diagram shows the wiring for the power and RS485 communications.

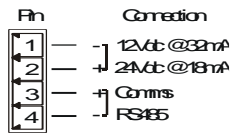

3.18.5 Switch Settings

SWITCH	FUNCTION	DESCRIPTION
1	NODE ID +1	Node ID's from 0 to 127 are set up using switches 1 to 7
2	NODE ID +2	"
3	NODE ID +4	"
4	NODE ID +8	"
5	NODE ID +16	"
6	NODE ID +32	"
7	NODE ID +64	"
8	OFFSET	When switched ON the outputs are scaled to accept a 2V offset .
9	MODE	Selects Master or Slave Mode. Master mode is used when the module is connected to a single Analog input module. Slave mode is used when the module is to be polled either by the I/O Mapper or by a PC.
10	BAUD RATE	Selects 9600 (off) or Programmed Baud Rate (on)

3.18.6 PM8VO Data Registers (MODULE TYPE = 111)

Modbus Address	Register Name	Low Limit	High Limit	Access	Comments
30001	S/W Version / Module Type	N/A	N/A	R	High Byte = Software Version Low Byte = 111
40002	Voltage Output 1	0	4095	R/W	Voltage Outputs. 0 - 4095 = 0 - 10V.
40003	Voltage Output 2	0	4095	R/W	"
40004	Voltage Output 3	0	4095	R/W	"
40005	Voltage Output 4	0	4095	R/W	"
40006	Voltage Output 5	0	4095	R/W	"
40007	Voltage Output 6	0	4095	R/W	"
40008	Voltage Output 7	0	4095	R/W	"
40009	Voltage Output 8	0	4095	R/W	"
40010	Output Status	0	65535	R	bit2 = 0(0), bit2 = 1(4095) bit1 = 0(OK),bit1 = 1(error)
30100	DIP Switch	0	65535	R	Status of DIP Switch on Front Panel
40101	Watchdog Timer	0	255	R/W	Timer in seconds. 0 = disabled. 1 -255 = enabled.
40102	Master Timeout	0	65535	R/W	Modbus Master Timeout (X10ms)
40103	Master Poll Rate	0	65535	R/W	Modbus Master Poll Rate (X10ms)
40121	Baud Rate	2400	18750	R/W	2400, 4800, 9600, 19200, 38400, 57600, 115200, 187500
40122	Parity	0	2	R/W	0 = none, 1 = even, 2 = odd
40123	Stop Bits	1	2	R/W	1 = 1 stop bit, 2 = 2 stop bits
40124	Reply Delay	0	255	R/W	0 = Disable, >0 = Enable. (x10ms)

3.18.7 Modbus Master Setup.

The module is configured as a Modbus master when switch 9 is on. The PM8VO reads digital inputs from a PM8AI/V module and writes the information to the outputs. The two modules must have the same network ID and these must be the only modules on the network.

3.18.7.1 Modbus Master Poll Rate.

The rate at which the PM8VO polls the PM8AI is configured using this register (40103). In some applications where a modem or radio is used in the RS485 network, it may be necessary to slow down the polling of the PM8AI due to turn around delays in the equipment.

3.18.7.2 Modbus Master Timeout.

The PM8VO polls the PM8AI to get the input data. If there is a problem and the message is corrupted or gets lost, then the PM8VO communications routine will timeout and try again. This parameter should be set to a larger value than the poll rate value.

3.19 PMIOMAP - I/O MAPPER

3.19.1 Description

The I/O Mapper is used for point-to-point communications where it is required to send input information from a PM16DI or PM8AI input module to a PM16DO or PM8AO output module over the network. The I/O Mapper is the Modbus master and all I/O modules must be set up as slaves. The I/O Mapper is only required if there is more than one pair of modules on the network.

When the I/O Mapper is used, The ID's of the Digital modules must be set up in the range 0 to 31 and the Analog modules must be set up in the range 32 to 47, starting at the bottom of the range. The Output module must be set to have the same ID as the input module.

The I/O Mapper can be configured as a Modbus Slave when the DIP switches are all off. This corresponds to an ID of zero (ID=0).

As soon as one of the switches is put on, the I/O Mapper becomes a Modbus master and starts sending out requests on the RS485 network.



3.19.2 Technical Specification of PMIOMAP

Power Supply	Logic Supply Voltage	12 -24 Vdc
	Logic Supply Current	21mA @ 12V / 13mA @ 24V
Temperature	Operating Temperature.	-40°C to + 80°C
	Storage Temperature	-40°C to + 85°C
Connectors	Logic Power and Comms.	4 Pin Connector on underside of unit

3.19.3 Status Indicators

- Power:** Flashes to indicate the CPU is running.
RS485 Rx: Flashes to indicate the unit has received a valid Modbus message.
RS485 Tx: Flashes to indicate the unit has sent a Modbus message.

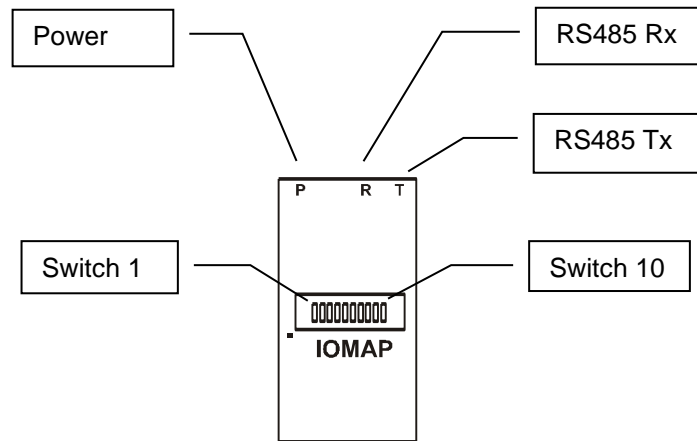

3.19.4 Wiring

The following diagram shows the wiring for the power and RS485 communications.

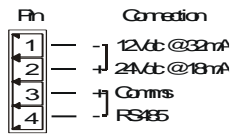

3.19.5 Switch Setting

SWITCH	FUNCTION	DESCRIPTION
1	No. of Digital Modules	The number of digital input/output pairs to be mapped
2	No. of Digital Modules	are set up with switches 1 to 5 inclusive. Node ID's for
3	No. of Digital Modules	digital modules are from 0 to 31.
4	No. of Digital Modules	
5	No. of Digital Modules	
6	No. of Analog Modules	The number of Analog input/output pairs to be mapped
7	No. of Analog Modules	are set up with switches 6 to 9 inclusive. Node ID's for
8	No. of Analog Modules	Analog modules are from 32 to 47.
9	No. of Analog Modules	
10	BAUD RATE	Selects 9600 (off) or Programmed Baud Rate (on)

3.19.6 PMIOMAP Data Registers (MODULE TYPE = 114)

Modbus Address	Register Name	Low Limit	High Limit	Access	Comments
30001	S/W Version / Module Type	N/A	N/A	R	High Byte = Software Version Low Byte = 114
30100	DIP Switch	0	65535	R	Status of DIP Switch on Front Panel
40101	Master Timeout	0	65535	R/W	Modbus Master Timeout (X10ms)
40102	Master Poll Rate	0	65535	R/W	Modbus Master Poll Rate (X10ms)
40121	Baud Rate	2400	18750	R/W	2400, 4800, 9600, 19200, 38400, 57600, 115200, 187500
40122	Parity	0	2	R/W	0 = none, 1 = even, 2 = odd
40123	Stop Bits	1	2	R/W	1 = 1 stop bit, 2 = 2 stop bits
40124	Reply Delay	0	255	R/W	0 = Disable, >0 = Enable. (x10ms)

3.19.7 Modbus Master Setup.

The module is configured as a Modbus master when any of the switches from 1 to 9 is on. The PMIOMAP reads digital inputs from a PM16DI module or reads analog inputs from a PM8AI module. The replies from the input modules are picked up by the output modules. This technique enables multiple output modules to pick up the input information from the same input module. The two modules must have the same network ID.

3.19.7.1 Modbus Master Poll Rate.

The rate at which the PMIOMAP polls the PM input modules is configured using this register (40102). In some applications where a modem or radio is used in the RS485 network, it may be necessary to slow down the polling of the PM input modules due to turn around delays in the equipment.

3.19.7.2 Modbus Master Timeout.

The PMIOMAP polls the PM input modules to get the input data. If there is a problem and the message is corrupted or gets lost, then the PMIOMAP communications routine will timeout and try again. This parameter should be set to a larger value than the poll rate value.

3.20 PMIOMAPTYPE2 - I/O MAPPER Type 2

3.20.1 Description

The I/O Mapper is used for point-to-point communications where it is required to send information from a PM16DI to PM16DO, PM8AI to a PM8AO, between 2 PM8DIO modules, between 2 PMDAIO modules or between 2 PMDAIO2 modules over the network. The I/O Mapper is the Modbus master and all I/O modules must be set up as slaves.

The I/O Mapper can be configured as a Modbus Slave when the DIP switches are all off. This corresponds to an ID of zero (ID=0).

The I/O MapperType2 is configured by setting up the Modbus registers. This can be done using the PC software utility program IOStudio.

As soon as one of the switches is put on, the I/O Mapper becomes a Modbus master and starts sending out requests on the RS485 network.



3.20.2 Technical Specification of PMIOMAPTYPE2

Power Supply	Logic Supply Voltage	12 -24 Vdc
	Logic Supply Current	21mA @ 12V / 13mA @ 24V
Temperature	Operating Temperature.	-40°C to + 80°C
	Storage Temperature	-40°C to + 85°C
Connectors	Logic Power and Comms.	4 Pin Connector on underside of unit

3.20.3 Status Indicators

- Power:** Flashes to indicate the CPU is running.
RS485 Rx: Flashes to indicate the unit has received a valid Modbus message.
RS485 Tx: Flashes to indicate the unit has sent a Modbus message.

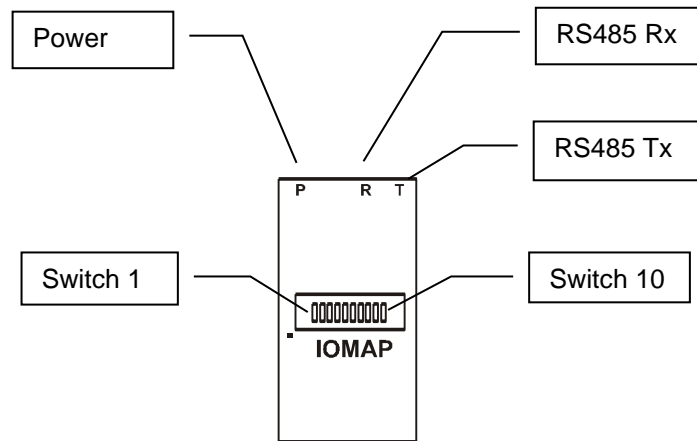

3.20.4 Wiring

The following diagram shows the wiring for the power and RS485 communications.

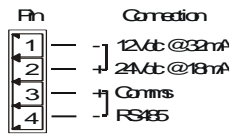

3.20.5 Switch Setting

SWITCH	FUNCTION	DESCRIPTION
1	MODE	Off = Slave, On = Master.
2	-	-
3	-	-
4	-	-
5	-	-
6	-	-
7	-	-
8	-	-
9	-	-
10	BAUD RATE	Selects 9600 (off) or Programmed Baud Rate (on)

3.20.6 PMIOMAPTYPE2 Data Registers (MODULE TYPE = 117)

Modbus Address	Register Name	Low Limit	High Limit	Access	Comments
30001	S/W Version / Module Type	N/A	N/A	R	High Byte = Software Version Low Byte = 117
30100	DIP Switch	0	65535	R	Status of DIP Switch on Front Panel
40101	Master Timeout	0	65535	R/W	Modbus Master Timeout (X10ms)
40102	Master Poll Rate	0	65535	R/W	Modbus Master Poll Rate (X10ms)
40121	Baud Rate	2400	18750	R/W	2400, 4800, 9600, 19200, 38400, 57600, 115200, 187500
40122	Parity	0	2	R/W	0 = none, 1 = even, 2 = odd
40123	Stop Bits	1	2	R/W	1 = 1 stop bit, 2 = 2 stop bits
40124	Reply Delay	0	255	R/W	0 = Disable, >0 = Enable. (x10ms)
40131	Module Pair 1	0	5	R/W	Slave Module ID's = 1(input) & 2(output) 0 = Disable 1 = PM16DI to PM16DO 2 = PM8DIO to PM8DIO 3 = PMDAIO to PMDAIO 4 = PM8AI to PM8AO or PM8AI to PM8VO 5 = PMDAIO2 to PMDAIO2
40132	Module Pair 2	0	5	R/W	Slave Module ID's = 3(input) & 4(output)
40133	Module Pair 3	0	5	R/W	Slave Module ID's = 5(input) & 6(output)
40134	Module Pair 4	0	5	R/W	Slave Module ID's = 7(input) & 8(output)
40135	Module Pair 5	0	5	R/W	Slave Module ID's = 9(input) & 10(output)
40136	Module Pair 6	0	5	R/W	Slave Module ID's = 11(input) & 12(output)
40137	Module Pair 7	0	5	R/W	Slave Module ID's = 13(input) & 14(output)
40138	Module Pair 8	0	5	R/W	Slave Module ID's = 15(input) & 16(output)
40139	Module Pair 9	0	5	R/W	Slave Module ID's = 17(input) & 18(output)
40140	Module Pair 10	0	5	R/W	Slave Module ID's = 19(input) & 20(output)
-	-	0	5	R/W	-
40180	Module Pair 50	0	5	R/W	Slave Module ID's = 99(input) & 100(output)

3.20.7 Modbus Master Setup.

The module is configured as a Modbus master when switch 1 is on. The PMIOMAP reads digital inputs from a PM16DI module or reads analog inputs from a PM8AI module. The replies from the input modules are then sent to the output modules. The ID of the input module is 1 less than the ID of the output module. Refer to the table above.

3.20.7.1 Modbus Master Poll Rate.

The rate at which the PMIOMAP polls the PM input modules is configured using this register (40102). In some applications where a modem or radio is used in the RS485 network, it may be necessary to slow down the polling of the PM input modules due to turn around delays in the equipment.

3.20.7.2 Modbus Master Timeout.

The PMIOMAP polls the PM input modules to get the input data. If there is a problem and the message is corrupted or gets lost, then the PMIOMAP communications routine will timeout and try again. This parameter should be set to a larger value than the poll rate value.

3.21 PM485REP – Isolated RS232/RS485 to RS485 Repeater

3.21.1 Description

The PM485REP unit is a bi-direction isolated serial repeater unit used to convert 2 wire RS485 twisted pair (or 3 wire RS232) data communications signals to another isolated 2 wire RS485 twisted pair cable. The unit is fully configurable via DIP switches for baud rate, parity, data bits and stop bits. The repeater can be used to extend a RS485 network up to a further 1000 metres. The isolation also prevents ground loops between different parts of the network.

The PM485REP is the ideal unit to use for isolating Promux modules housed in an electrical panel from long RS485 networks which could suffer from ground loop problems.

The PM485REP can also be used as a RS232 to RS485 isolated converter.



3.21.2 Technical Specification of PM485REP

Power Supply	Logic Supply Voltage	12 -24 Vdc
	Logic Supply Current	50mA @ 12V / 25mA @ 24V
Communications Settings (Switch Selectable)	Baud Rate	2400, 4800, 9600, 19200, 38400, 57600, 115200
	Data Bits	7 or 8
	Stop Bits	1 or 2
	Parity	None, Even or Odd
PORT 0	RS232 or RS485 (selected internally with jumpers)	Two wire twisted pair + earth wire
PORT 1	RS485	Two wire twisted pair + earth wire
Transmission Distance	RS485	Up to 1Km
Isolation	RS485	Transformer/OptoCoupler 1500VACrms
Propagation Delay	RS485	One Character
Temperature	Operating Temperature.	-40°C to + 80°C
	Storage Temperature	-40°C to + 85°C
Connectors	Logic Power and Comms.	4 Pin Connector on underside of unit
	Isolated RS485 Comms.	4 Pin Connector on front of unit.

3.21.3 Status Indicators

- Power:** Flashes to indicate the CPU is running.
- RS485 Rx:** Flashes to indicate the unit has received a valid Modbus message.
- RS485 Tx:** Flashes to indicate the unit has sent a Modbus message.

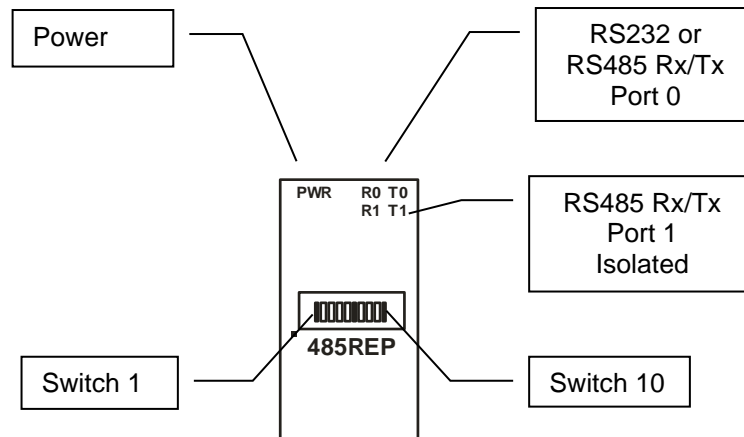

3.21.4 Wiring

The following diagram shows how the isolated RS485 (Port 1) network is connected to the repeater. The GND terminal is used as the third wire to ensure the common mode voltage on the RS485 network is kept within limits.

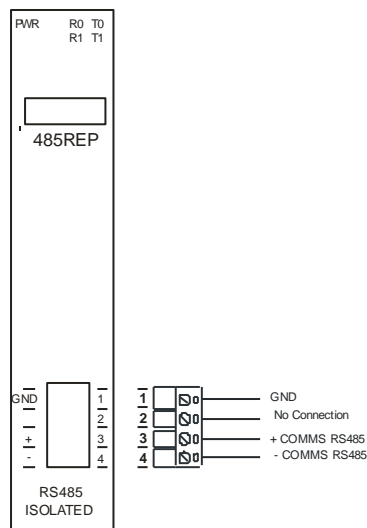

The following diagram shows the wiring for the power and RS232 or RS485 communications Port 0.

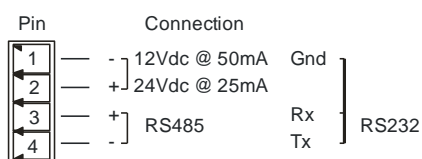

3.21.5 Switch Setting

SWITCH	FUNCTION	ON	OFF
1/2/3	Baud Rate 9600	-	S1/S2/S3
1/2/3	Baud Rate 2400	S1	S2/S3
1/2/3	Baud Rate 4800	S2	S1/S3
1/2/3	Baud Rate 9600	S1/S2	S3
1/2/3	Baud Rate 19200	S3	S1/S2
1/2/3	Baud Rate 38400	S1/S3	S2
1/2/3	Baud Rate 57600	S2/S3	S1
1/2/3	Baud Rate 115200	S1/S2/S3	-
4/5	Parity None	-	S4/S5
4/5	Parity Even	S4	S5
4/5	Parity Odd	S5	S4
6	Stop Bits - 1	-	S6
6	Stop Bits - 2	S6	-
7	Data Bits - 8	-	S7
7	Data Bits - 7	S7	-
8	-	-	
9	-	-	
10	-	-	

3.22 PMFIBRE – RS232/RS485 to FIBRE

3.22.1 Description

The PMFibre Optic converter unit is a bi-direction fibre optic unit used to convert 2-wire RS485 twisted pair (or 3 wire RS232) data communications signals for transmission over multi-mode fibre optic cables.

The converters can be used to extend the limited distance capabilities of RS485 devices for up to two kilometres. The PMFibre Optic converter is ideal for extending RS485 signals through areas of high electrical noise due to the EMI immunity of fibre.

The unit is also ideal for isolating Promux modules housed in an electrical panel from long RS485 networks which could suffer from ground loop problems.

The unit is fully configurable via DIP switches for baud rate, parity, data bits and stop bits. The isolation also prevents ground loops between different parts of the network.



3.22.2 Technical Specification of PMFIBRE

Power Supply	Logic Supply Voltage	12 -24 Vdc
	Logic Supply Current	50mA @ 12V / 25mA @ 24V
Communications Settings (Switch Selectable)	Baud Rate	2400, 4800, 9600, 19200, 38400, 57600, 115200
	Data Bits	7 or 8
	Stop Bits	1 or 2
	Parity	None, Even or Odd
PORT 0	RS232 or RS485 (selected internally with jumpers)	Two wire twisted pair + earth wire
PORT 1	Fibre Optic	50/125µm, 62.5/125µm, and 100/140µm.
	Transmission Wavelength	850 Nanometre. Multi-Mode.
Transmission Distance	RS485	Up to 1Km
	Fibre	Up to 2 Km depending on attenuation of fibre used.
Propagation Delay	RS232/RS485 to Fibre	One Character
Temperature	Operating Temperature.	-40°C to + 80°C
	Storage Temperature	-40°C to + 85°C
Connectors	Logic Power and Comms.	4 Pin Connector on underside of unit
	Isolated RS485 Comms.	4 Pin Connector on front of unit.
	Fibre connectors	Supplied with either SMA or ST connectors.

3.2.2.3 Status Indicators

- Power:** Flashes to indicate the CPU is running.
Rx: Flashes to indicate the unit has received a valid Modbus message.
Tx: Flashes to indicate the unit has sent a Modbus message.

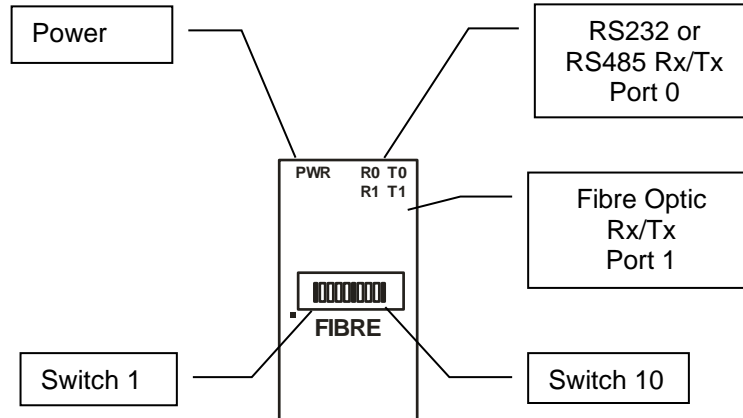

3.2.2.4 Wiring

The following diagram shows the wiring for the power and RS232 or RS485 communications Port 0.

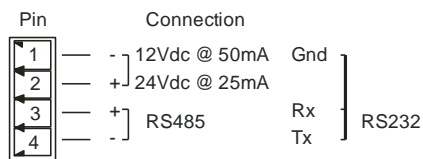

3.2.2.5 Switch Setting

SWITCH	FUNCTION	ON	OFF
1/2/3	Baud Rate 9600	-	S1/S2/S3
1/2/3	Baud Rate 2400	S1	S2/S3
1/2/3	Baud Rate 4800	S2	S1/S3
1/2/3	Baud Rate 9600	S1/S2	S3
1/2/3	Baud Rate 19200	S3	S1/S2
1/2/3	Baud Rate 38400	S1/S3	S2
1/2/3	Baud Rate 57600	S2/S3	S1
1/2/3	Baud Rate 115200	S1/S2/S3	-
4/5	Parity None	-	S4/S5
4/5	Parity Even	S4	S5
4/5	Parity Odd	S5	S4
6	Stop Bits - 1	-	S6
6	Stop Bits - 2	S6	-
7	Data Bits - 8	-	S7
7	Data Bits - 7	S7	-
8	-	-	-
9	-	-	-
10	-	-	-

3.22.6 Setting the jumpers for RS485.

The communications Port 0 can be configured as a RS485 port by placing the jumpers for J5, J6 & J7 on position 1-2.

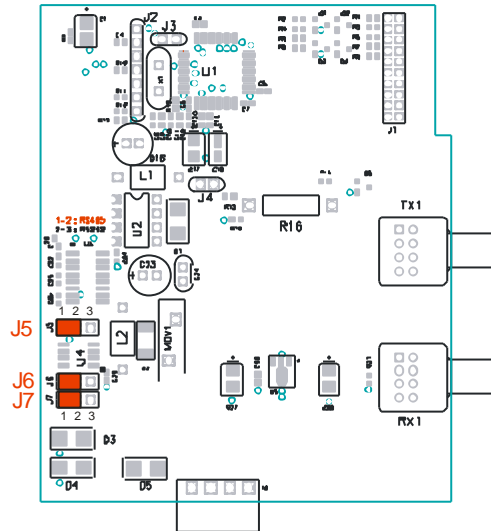

3.22.7 Setting the jumpers for RS232.

The communications Port 0 can be configured as a RS232 port by placing the jumpers for J5, J6 & J7 on position 2-3.

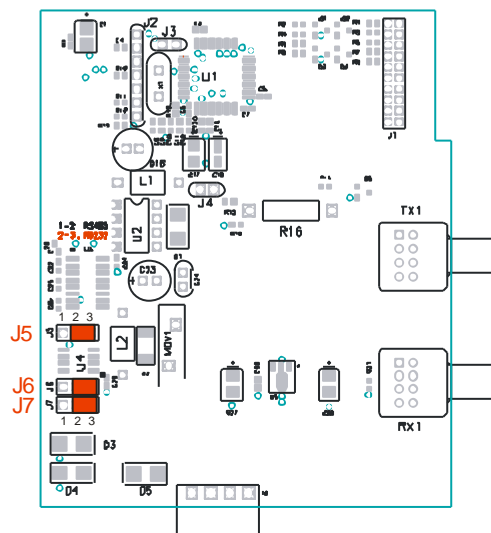

3.22.8 Order Codes.

Order Code

PM485FIBRE/SMA
MM485FIBRE/ST

Description

RS232 / RS485 FIBRE OPTIC CONVERTER SMA CONNECTOR 850nm
RS232/RS485 FIBRE OPTIC CONVERTER ST CONNECTOR 850nm

4. SPECIFICATIONS

4.1 ENVIRONMENTAL

Operating Temperature	-30°C to +80°C
Storage Temperature	-40°C to +85°C
Humidity	Up to 95% non condensing.

4.2 EMC INSTALLATION INSTRUCTIONS

1. Screened twisted pair RS485 cable must be used with the screen grounded at one point only.
2. The RS485 cable must be terminated at both ends using a 120 ohm resistor.
3. Use should be made of screened I/O, T/C, RTD cable with the screens grounded at one point as close to the PROMUX module as possible.
4. The PROMUX modules must be installed in an appropriate enclosure inaccessible to the operator during normal use.

4.3 CONFORMITY CERTIFICATE

DECLARATION OF CONFORMITY according to EN 45014		
Manufacturer's Name:	Procon Electronics CC	
Manufacturer's Address:	26 Wareing Park 2 Wareing Road Pinetown 3610 South Africa	
declares that the product		
Product Name:	PROMUX	
Model Number(s):	PM16DI, PM16DI110, PM16DI220, PM16DO, PM8DIO, PM4RO, PM8AI/I, PM8AI/V, PM8AI/IISO, PM8AI/VISO, PM8AO, PM8VO, PM8TC, PM8TCISO, PM6RTD, PMDAIO, PMDAIO2, PMI/OMAP, PMI/OMAPTYPE2, PM485REP.	
complies with EMC Directive 89/336/EEC and Low Voltage Equipment Directive 73/23/EEC and conforms to the following Product specifications:		
EMC:	EN 61326-1 Electrical Equipment for measurement, control and laboratory use.	
<u>Pinetown, SA</u> Location	<u>August 2006</u> Date	D.Ruddock

4.4 EMC Test Results

PROMUX EMC Test Results									
Test	Standard	Test Value	PROMUX Product Compliance (PM)						
Immunity Test Results EN 61326-1			16DI	16DO	4RO	8DIO	8AII	8AII ISO	8AIV
Electrostatic Discharge	IEC 61000-4-2	8KV Air	A	A	A	A	A	B	A
		4KV Contact	A	A	A	A	A	A	A
Radiated Field	IEC 61000-4-3	10V/m	A	A	A	A	A	A	A
Fast Transients	IEC 61000-4-4	Power 2KV	A	A	A	A	A	B	A
		I/O 1KV	A	A	A	A	A	B	A
Surge	IEC 61000-4-5	Power 1KV/2KV	A	A	A	A	A	A	A
RF Conducted	IEC 61000-4-6	Power 3 Vrms	A	A	A	A	A	A	A
Voltage Interrupt	IEC 61000-4-11	0.5cycle 100%	A	A	A	A	A	A	A
Emissions Test Results EN 61326-1 Class A									
Radiated Emissions	CISPR 22	Class A	✓	✓	✓	✓	✓	✓	✓
Conducted Emissions	CISPR 22	Class B	✓	✓	✓	✓	✓	✓	✓

Test	Standard	Test Value	PROMUX Product Compliance (PM)						
Immunity Test Results EN 61326-1			8AIV ISO	8TC	8TC ISO	6RTD	DAIO	8AO	8VO
Electrostatic Discharge	IEC 61000-4-2	8KV Air	B	A	B	A	A	A	B
		4KV Contact	A	A	A	A	A	A	A
Radiated Field	IEC 61000-4-3	10V/m	A	A	A	A	A	A	A
Fast Transients	IEC 61000-4-4	Power 2KV	B	A	B	A	A	A	A
		I/O 1KV	B	A	B	A	A	A	A
Surge	IEC 61000-4-5	Power 1KV/2KV	A	A	A	A	A	A	A
RF Conducted	IEC 61000-4-6	Power 3 Vrms	A	A	A	A	A	A	A
Voltage Interrupt	IEC 61000-4-11	0.5cycle 100%	A	A	A	A	A	A	A
Emissions Test Results EN 61326-1 Class A									
Radiated Emissions	CISPR 22	Class A	✓	✓	✓	✓	✓	✓	✓
Conducted Emissions	CISPR 22	Class B	✓	✓	✓	✓	✓	✓	✓