

JUMO flowTRANS US W01

Ultrasonic flowmeter
for liquids



Operating Manual



40605000T90Z001K000

V1.00/EN/00729317/2022-01-17

Further information and downloads



qr-406050-en.jumo.info

1	About this documentation	5
1.1	Purpose	5
1.2	Target group	5
1.3	Definition of terms	5
1.4	Symbols	5
2	Safety	6
2.1	Safe operation	6
2.2	Intended use	6
2.3	Qualification of personnel	6
2.4	Hot media	6
2.5	Hazardous materials	7
3	Device Description	8
3.1	Design	8
3.2	Function	8
3.3	Nameplate	9
4	Technical data	10
4.1	Input	10
4.1.1	Measuring range and accuracy	10
4.1.2	Reference conditions	10
4.2	Output	11
4.2.1	Analog output	11
4.2.2	Digital output	11
4.3	Electrical data	12
4.4	Mechanical features	12
4.4.1	Materials	12
4.4.2	Nominal pressure	12
4.4.3	Pressure loss diagram	12
4.5	Measurement media	13
4.6	Environmental influences	13
5	Acceptance of goods, storage, and transport	14
5.1	Scope of delivery	14
5.2	Checking the delivery	14
5.3	Storage	14
5.4	Packaging and transport	14
6	Installation	15
6.1	Prepare installation	15
6.2	Installing the device	17

Contents

7	Electrical connection	18
7.1	Preparing the electrical connection	18
7.1.1	Pin assignment of the M12 connector	18
7.1.2	Connection of analog output	19
7.1.3	Connection of digital output	19
7.2	Connecting the device	21
8	Operation	22
8.1	Display and control elements	22
8.2	Troubleshooting	22
9	Maintenance and cleaning	23
9.1	Cleaning device housing	23
9.2	Cleaning parts that come into contact with the medium and replacing O-rings	23
9.3	Decontaminating the device	23
10	Shutdown	24
10.1	Uninstalling the device	24
10.2	Returning devices	24
10.3	Disposal	24
11	Accessories	25
12	China RoHS	26

1 About this documentation

1.1 Purpose

This documentation is part of the device and includes all information to ensure that it is used safely and as intended across all phases of the product lifecycle.

If you do not follow the documentation and safety information, this may result in risk to life and damage to property due to improper use.

- Follow the documentation and the safety information and warnings.
- Store the document in its entirety, in an easily accessible location, and so that it can be read in full at all times.
- Contact the manufacturer if you have any questions about the device and documentation.

1.2 Target group

This documentation is intended to be used by trained electrical, mechanical, and plant engineering personnel across all phases of the product lifecycle.

1.3 Definition of terms

Use in the documentation	Definition
Device, inline device, product	Ultrasonic flowmeter 406050
Medium, measurement medium, fluid	Liquid
Transducer	Ultrasonic converter, sensor
Product lifecycle	Overall consideration of Product identification, acceptance of the goods, storage, mounting, connection, operation, troubleshooting, maintenance to disposal

1.4 Symbols



NOTE!

This symbol refers to **important information** about the product, its handling, or additional benefits.



NOTE!

This symbol is used in tables and indicates that further information is provided after the table.



REFERENCE!

This symbol refers to **further information** in other sections, chapters, or other manuals.

2 Safety

2.1 Safe operation

This device is built based on current state-of-the-art technology and is safe to use. The device has been tested and was shipped from the plant in perfect working order.

If you do not follow the measures to ensure safe operation, this may result in risk to life and damage to property due to improper use.

- Only ever use the device for its intended purpose.
- Do not place the device and the process connections under mechanical strain.
- Systematically check that the process connections are leak-tight.
- Protect the device from electromechanical interference and UV radiation.
- Protect the device from the weather (when using outside).
- Only perform modifications and repairs to the device if expressly permitted by the documentation.

2.2 Intended use

The ultrasonic flow meter measures the volume flow of conductive and non-conductive media. The volume flows can be output in analogue as a current signal (4 to 20 mA) and digitally as a pulse signal (0 to 10 kHz).

Usage	Suitable	Not suitable
Continuous measurement of the volume flow	x	
Conductive and non-conductive media	x	
Potentially explosive areas and safety applications		x

During operation, the admissible data and operating conditions specified in the legal documents and operating manual must be observed.

2.3 Qualification of personnel

The personnel deployed must meet the following requirements in all phases of the product lifecycle:

- Trained electrical, mechanical, and plant engineering personnel.
- Members of personnel are familiar with this documentation and the safety information and warnings it contains.

2.4 Hot media

Hot media may result in the device surfaces becoming hot and presenting a risk of injury.

- Allow the device and plant to cool down.
- Wear suitable protective equipment.
- Take into account alignment of the housing for electronic components.
⇒ "Alignment of the housing for electronic components", Page 16
- If required, install contact protection.

2.5 Hazardous materials

Using hazardous materials as a medium may result in abrasive and corrosive damage to components of the device that come into contact with the medium. The medium may leak and present a fire hazard and a risk to health.

Carry out a risk assessment taking into consideration the safety data sheet for the hazardous substances concerned for mounting, operation, maintenance, cleaning, and disposal:

- Comparison and systematic checking of the durability of the components of the device that come into contact with the medium and the admissible environmental influences.
- Assessment of the risk to people and the environment.
- Assessment of the fire hazard due to the device materials, the admissible environmental influences, and the voltage supply.

3 Device Description

3.1 Design

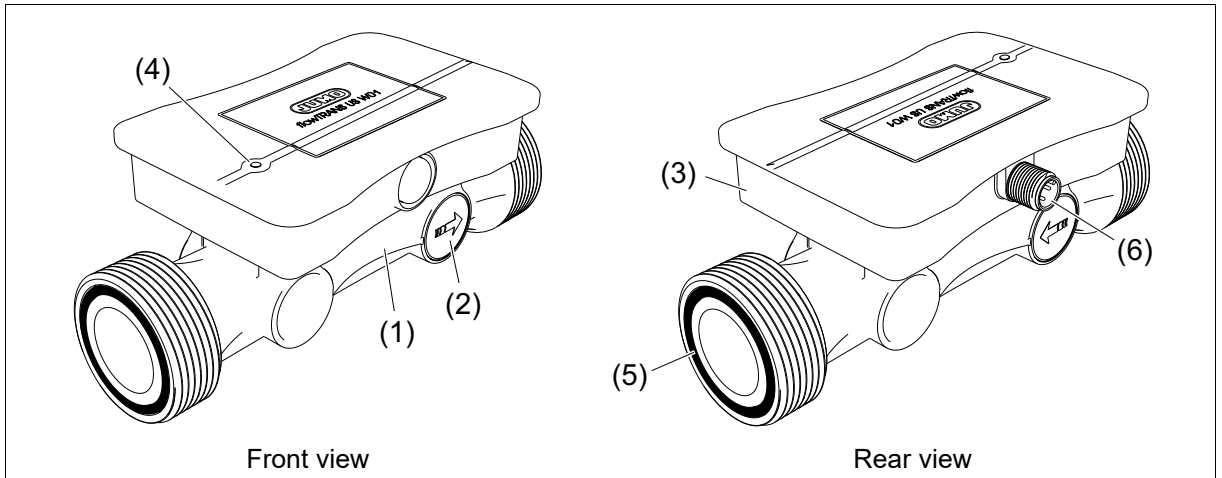

- | | |
|---------------------------------------|--|
| (1) Meter run | (4) Device status LED |
| (2) Transducer (ultrasonic converter) | (5) O-ring (seal for the process connection) |
| (3) Housing for electronic components | (6) M12 plug connection (4-pole) |

3.2 Function

The transducers are on opposite sides of the meter run and act as transmitters and receivers, i.e. they convert the electrical energy into sound waves and the sound waves into electrical energy.

The electronic components supply power to the device, convert the raw signals into standard signals for communicating with other systems (PLC, recorder, indicating device, etc.), and provide interfaces for displaying measured values.

Function principle

The ultrasonic flowmeter works according to the runtime method.

This method measures the runtimes t_1 and t_2 required by the sound to travel from transducer A to transducer B and vice versa.

→ = Flow direction

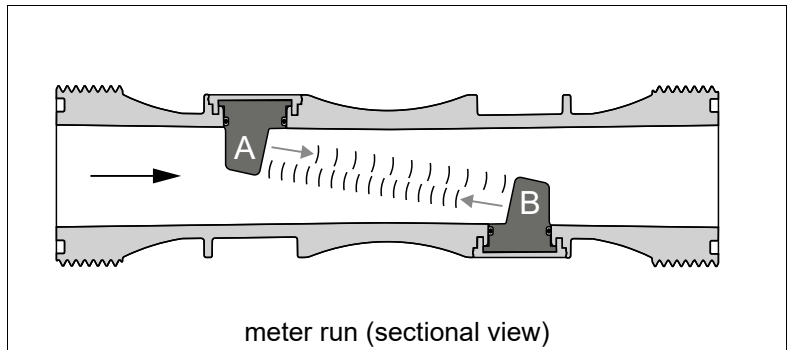

The runtime differential Δt is directly proportional to the flow velocity of the medium.

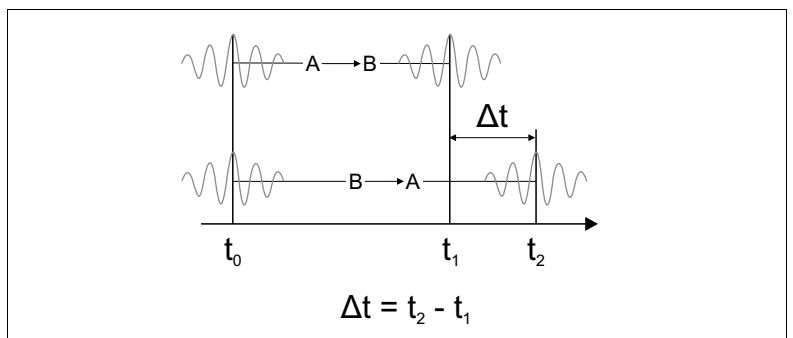

3.3 Nameplate

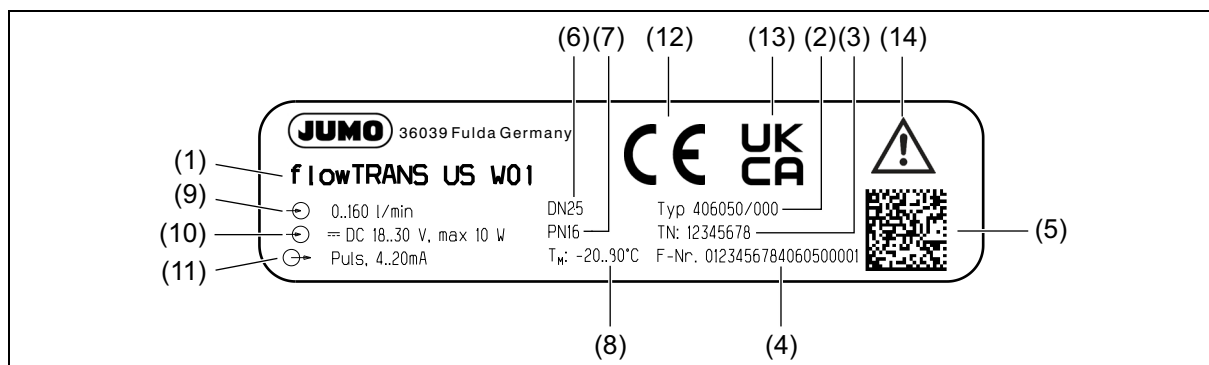

- | | |
|---|---|
| (1) Manufacturer and device designation | (9) Measuring range |
| (2) Product group number | (10) Voltage supply
(= DC Symbol for direct voltage) |
| (3) Part no. | (11) Output signal |
| (4) Fabrication number | (12) EU conformity label |
| (5) Fabrication number as a DMC code | (13) UK conformity label |
| (6) Nominal width | (14) Observe device documentation! |
| (7) Nominal pressure level | |
| (8) Medium temperature | |



READ THE DOCUMENTATION!

This symbol, which is attached to the device, indicates that the associated **documentation for the device** must be **observed**. This is necessary to identify the nature of the potential hazard, and to take measures to prevent it.

4 Technical data

4.1 Input

4.1.1 Measuring range and accuracy

Nominal width	Default settings for analog output ^{a, b}	Flow _{max} ^a
DN 15 (Low-flow calibration)	0 to 30 l/min	60 l/min
DN 15	0 to 62.5 l/min	80 l/min
DN 20	0 to 105 l/min	210 l/min
DN 25	0 to 160 l/min	320 l/min
DN 32	0 to 260 l/min	520 l/min

^a Low flow cut off: 0.05 % of flow_{max}.

^b Optionally expandable up to flow_{max}.

<p>X = Flow_{max} (%)</p> <p>Y = Measuring deviation from the measured value ± (%)</p>	
Measuring deviation ^a	
Pulse output	≤ ±2.0 % of measured value ±0.1 % of flow _{max}
Current output	Like pulse output, additionally ≤ ±0.1 % of 20 mA
Voltage output	Like pulse output, additionally ≤ ±0.1 % of 10 V
Reproducibility	≤ ±0.5 % of measured value ^a ±0.03 % of flow _{max}
Temperature drift	≤ ±0.15% of measured value ^a per 10 K temperature change (at -20 to +80° C)
Response time t ₉₀	≤ 2 s

^a Under reference conditions.

4.1.2 Reference conditions

Measurement medium	Water
Medium temperature	23 °C (73 °F) ±5 K
Ambient temperature	23 °C (73 °F) ±5 K
Medium pressure	1 to 4 bar
Meter run	Horizontal installation, compliance with the required inlet and outlet sections

4.2 Output

4.2.1 Analog output

Type	Current output
Function	Output of the current flow rate, output of a signal for error messages, display via device status LED
Signal range	4 to 20 mA
Signal limits	3.8 to 20.5 mA
Error message	3.4 or 22 mA (default settings: 3.4 mA)
Temperature influence	75 ppm/K
Burden	≤ 500 Ω
Burden influence	≤ ±0.02 % per 100 Ω

Type	Voltage output (optionally)
Function	Output of the current flow rate, output of a signal for error messages, display via device status LED
Signal range	DC 0 to 10 V
Signal limits	DC 0 to 10.3 V
Error message	DC 0 or 11 V (default settings: 0 V)
Temperature influence	75 ppm/K
Burden	≥ 700 Ω
Burden influence	≤ ±0.02 % per 100 Ω

4.2.2 Digital output

Type	Transistor output
Function	Pulse output
Switching output	Push-Pull, PNP/NPN (optionally)
Ampacity	≤ 200 mA
Voltage drop	≤ 2 V
Protection	Against polarity reversal, short circuiting and overload
Pulse frequency	0 to 10 kHz
Duty cycle	50 %
Output value at nominal width	Pulses per Liter (l)
DN 15 (Low-flow calibration)	10000
DN 15	4800
DN 20	2850
DN 25	1875
DN 32	1150

4 Technical data

4.3 Electrical data

Voltage supply	DC 18 to 30 V SELV, PELV, Class 2
Current consumption	50 mA, with digital output 300 mA
Power consumption	≤ 10 W
Protection rating	DIN EN 61140, Class III (protective low voltage)
Electrical safety	The device must be equipped with an electrical circuit that meets the requirements of DIN EN 61010-1 with regard to "Limited-energy circuits".

4.4 Mechanical features

4.4.1 Materials

Housing	PA66-GF25
Components in contact with the medium	
Meter run	PPSU
Transducer	PEEK
Seals	
Process connection, transducer	EPDM or FKM (optionally)
Approvals	
Components in contact with the medium	Drinking water certified materials (when using EPDM seals)

4.4.2 Nominal pressure

Nominal pressure levels	PN 16
-------------------------	-------

4.4.3 Pressure loss diagram

Created under reference conditions ⇒ "Reference conditions", Page 10.

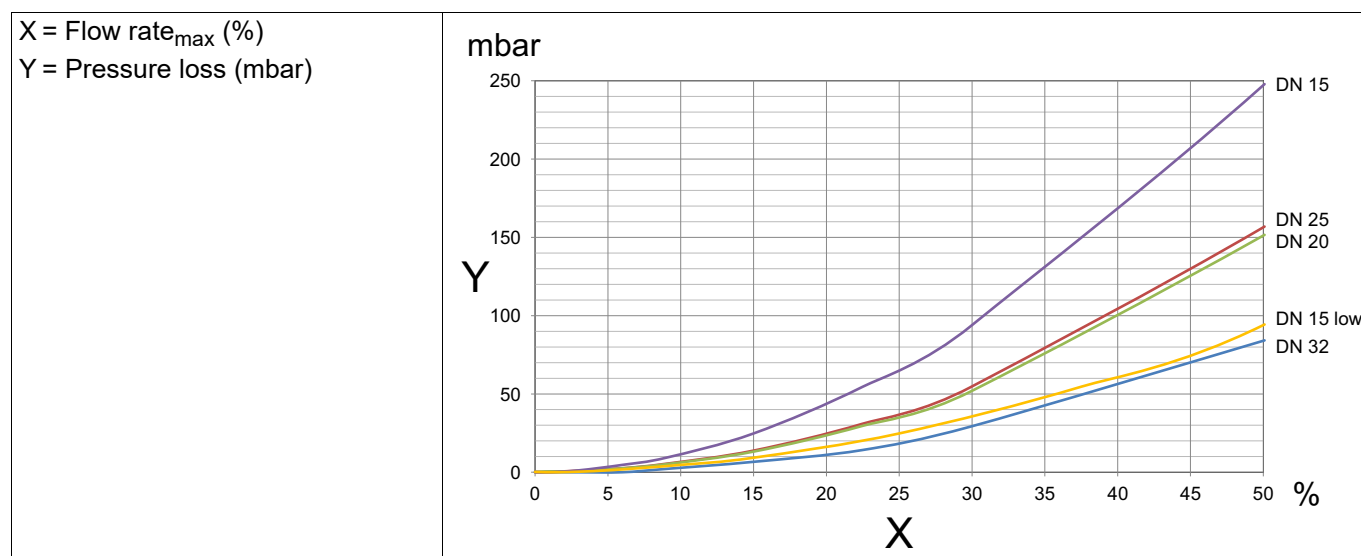

4.5 Measurement media

Medium type	Conductive or non-conductive liquids
Viscosity	≤ 100 mPas
Foreign matter content	
Solids	≤ 5 % vol
Gases	≤ 1 % vol
Medium temperature	
Temperature range	-20 to +95 °C
within the accuracy specifications	-20 to +80 °C
outside of the accuracy specifications ^a	> 80 to 95 °C

^a Return to the accuracy specifications after cooling down.

4.6 Environmental influences

Admissible ambient temperature	DIN 60068-2-1, DIN 60068-2-2
at a medium temperature of ≤ 80 °C	-20 to +70 °C
at a medium temperature of > 80 °C	-20 to +45 °C
Climatic conditions	DIN EN 60721-3-1, DIN EN 60721-3-3, DIN EN 60068-2-78
Climate class	3K6
Temperature range	-20 to +55 °C
Relative humidity	≤ 100 % – Condensation on device outer shell
Protection type	DIN EN 60529, EN 50102 IP65, IP67
Electromagnetic compatibility (EMC)	DIN EN 61326-1, DIN EN 61326-2-3
Interference emission	Class B ^a
Interference immunity	Industrial requirements
Vibration resistance	DIN EN 60068-2-6, DIN EN 60068-2-27
Vibration resistance	5 g at 10 to 2000 Hz
Shock resistance	20 g over 11 ms
Pressure Equipment Directive	2014/68/EU
Group 1 fluids - DN ≤ 25	Sound engineering practice acc. to Art. 4, para. 3 i. c. w. Art. 4 para. 1c.i
Group 2 fluids - DN ≤ 32	Sound engineering practice acc. to Art. 4, para. 3 i. c. w. Art. 4 para. 1c.i
Group 1 fluids	Sound engineering practice acc. to Art. 4, para. 3 i. c. w. Art. 4 para. 1c.ii

^a The product is suitable for industrial use as well as for households and small businesses.

5 Acceptance of goods, storage, and transport

5.1 Scope of delivery

1× JUMO flowTRANS US W01 – Device in the ordered version, including test certificate
2× O-ring (seal for the process connection) in the ordered version
1× JUMO flowTRANS US W01 operating manual

5.2 Checking the delivery

- Ensure that the packaging and its contents are undamaged.
- Check the delivery for completeness against the packing slip and order details.
- Inform the supplier immediately if there is any damage.
- Store damaged parts until clarification is received from the supplier.

5.3 Storage

Improper storage may result in damage to the device.

- Store the device in a dry and dust-free environment.
- Observe the device storage temperature range.

5.4 Packaging and transport

If the device is not protected properly against external influences, it may become damaged during transport.

- Transport the device in an impact-proof packaging solution that protects it against moisture and dirt.
- Also comply with the admissible storage temperatures while the device is being transported.
- Seal any electrical interfaces with protective caps to protect them against damage.

6.1 Prepare installation

Requirements:

- Check the environmental influences to which the device will be exposed.
- Switch off the plant's voltage and secure it so that it cannot switch on again.
- Stop medium circulation in the plant.
- Drain and flush the pipe.
- Wear suitable protective equipment.
- Correctly prepare the pipe for installation.
- Use only suitable tools when working on the device and plant.

Inlet and outlet sections

To calm the flow in the pipeline, the specified inlet and outlet sections are required at the very least.

For increased accuracy, the inlet and outlet sections can be made longer.

DN = Nominal pipe width

→ = Flow direction

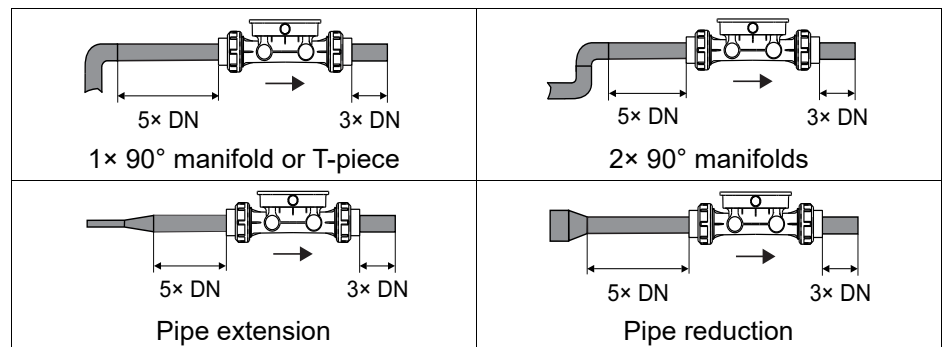

Installation position

Mount the device in either the horizontal or vertical pipe.

Requirements:

- The pipe around the transducers must be filled.
- The flow direction (→) must run upward when mounting vertically.
- Avoid the formation of air bubbles in the pipe and right at the device.

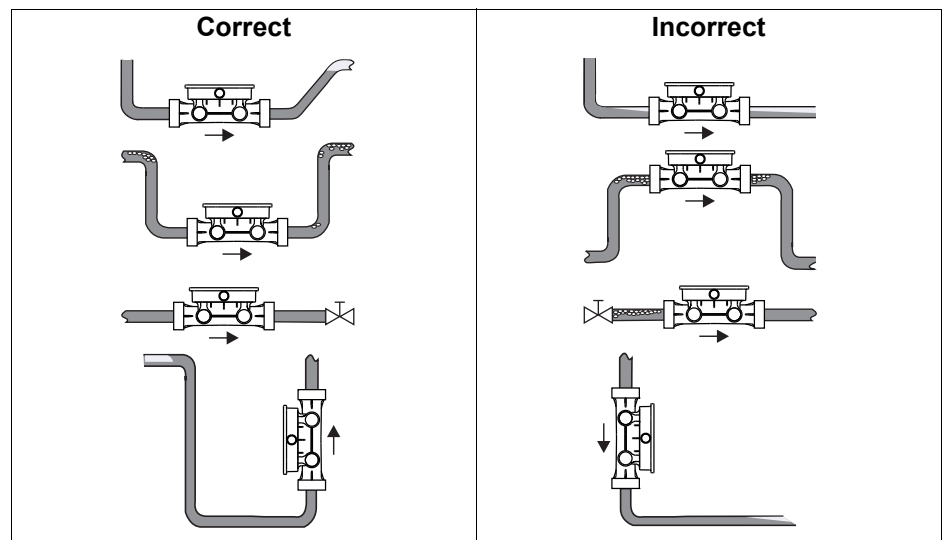

6 Installation

Avoid mechanical strain

Ensure that the center lines of both ends of the pipes align before installing in the pipe (3).

Align the ends of the pipes parallel and at an angle to one another.

Adhere to the insertion length L of the device.

Installation accessories are available from the manufacturer.

Each mounting set contains two union ends (1) and two union nuts (2). Select the correct set for the nominal width and pipe material in question.

For the table of dimensions for the mounting sets, please see:

⇒ [Data sheet](#).

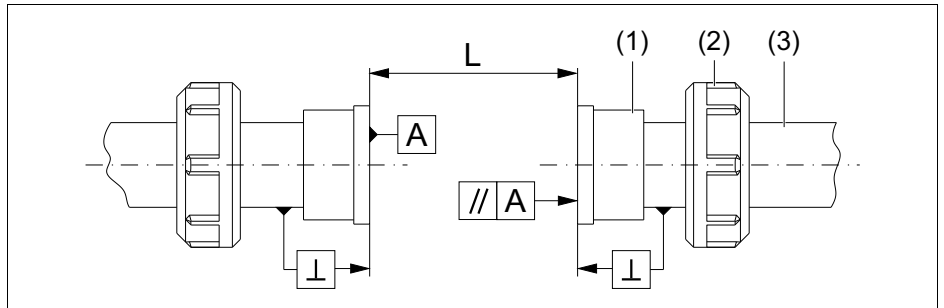

Nominal width	Insertion length L [mm]
DN 15	160
DN 20	165
DN 25	175
DN 32	185

Flow direction

The positive flow direction (→) is shown on the transducer covers on both sides of the device and must be observed during installation, in accordance with the application in question.

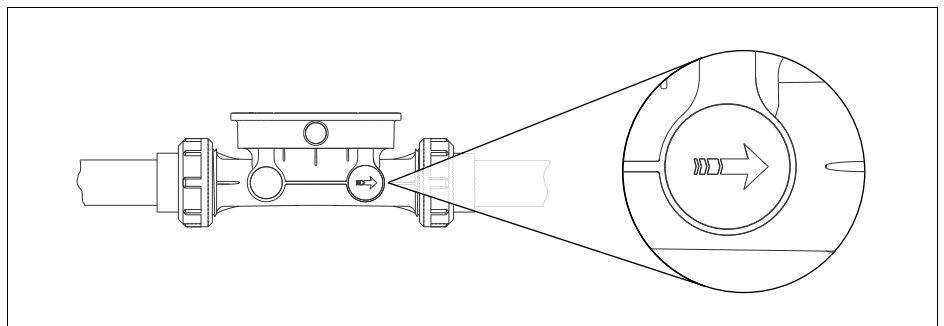

Alignment of the housing for electronic components

CAUTION! Protect the electronics housing from being heated up by hot media. Install the electronics housing at medium temperatures > 60 ° C (140 ° F) aligned 90 ° to the side!

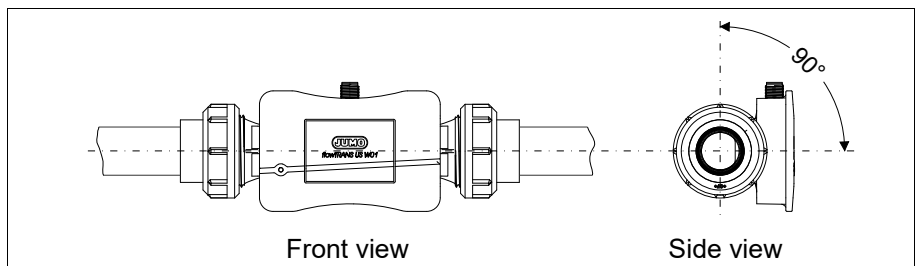

6.2 Installing the device

1. Insert the O-rings supplied into the sealing ring grooves in the two process connections.

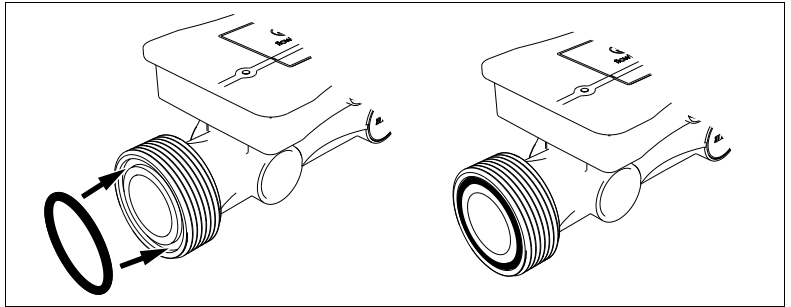

2. Install the device between the two union ends of the mounting set.

Ensure that the O-rings (2) between the process connections (1) and union ends (3) are correctly positioned.

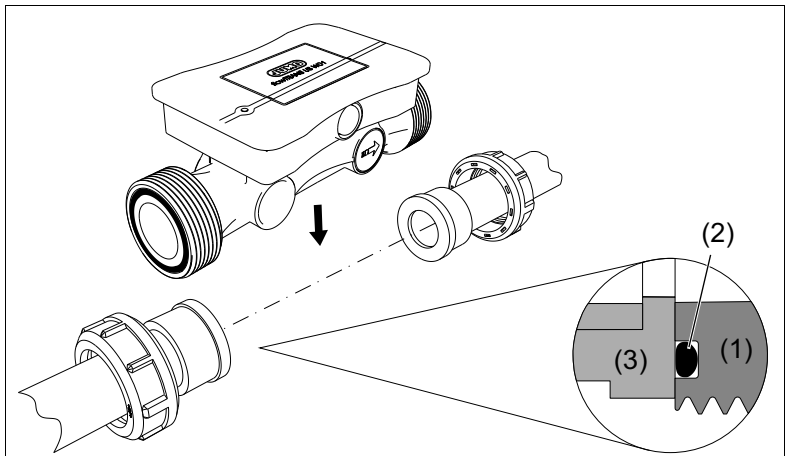

3. Manually screw union nuts on both ends of the pipe to the process connections on the device.

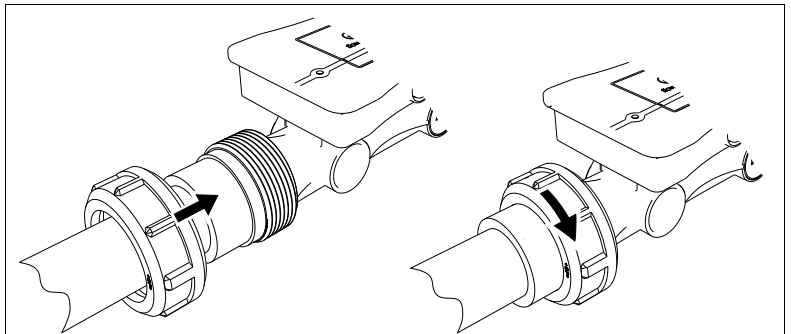

The device is now installed in the pipe.

7 Electrical connection

7.1 Preparing the electrical connection

Requirements:

- Switch off the plant's voltage and secure it so that it cannot switch on again.
- Correctly prepare the connections for the voltage supply and signal processing. The device must be equipped with an electrical circuit that meets the requirements of DIN EN 61010-1 with regard to "Limited-energy circuits".
- Voltage supply: DC 18 to 30 V SELV, PELV.
- Use a cable that has a temperature resistance suitable for the process.
- Do not lay the cable near high-voltage or high-frequency cables; if you cannot avoid doing so, maintain a minimum gap of 30 cm.

7.1.1 Pin assignment of the M12 connector

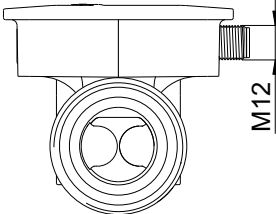
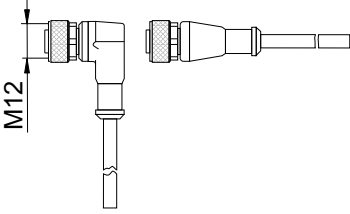
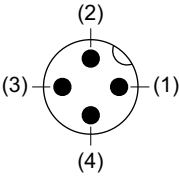
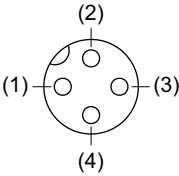
Connection	Device 	Connecting cable^a 
Pin assignment and color coding ^b Figure  Voltage supply V+ (DC 18 to 30 V) (1) Analog output (2) GND (3) Digital output (4)	 (1) BN (brown) (2) WH (white) (3) BU (blue) (4) BK (black)	
Connection type	Plug connector M12	Plug connector M12 with screw locking

^a Connecting cable for plug connector M12 ⇒ "Accessories", Page 25.

^b The color coding is only valid for A-coded standard cables!

7 Electrical connection

7.1.2 Connection of analog output

Current output – 4 to 20 mA

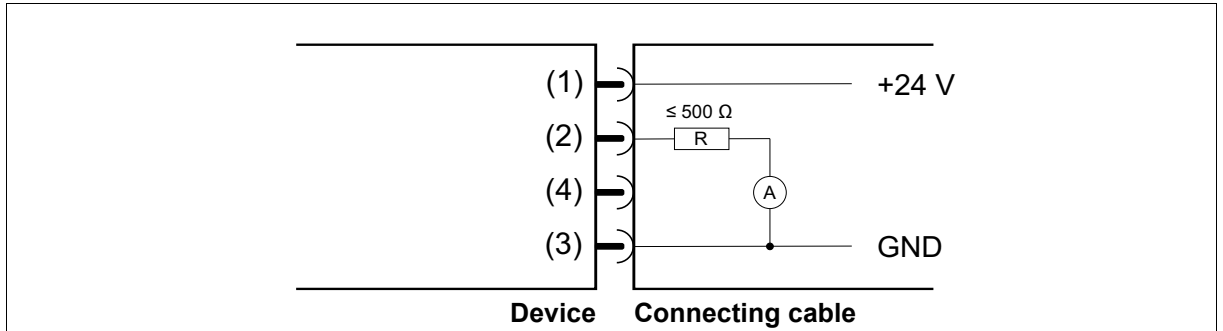

Voltage output – 0 to 10 V (optionally)

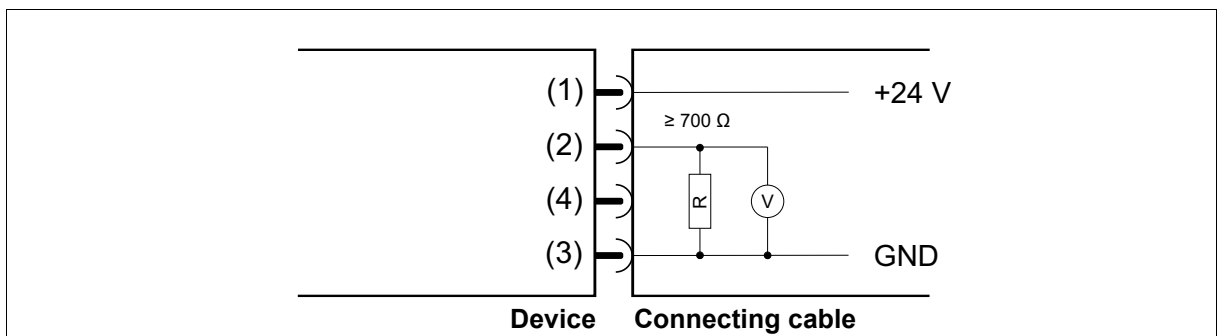

7.1.3 Connection of digital output

Requirements:

- Connect an unused current output (2) to GND (3).
- Leave an unused optional voltage output (2) open.

Pulse output – push-pull (example 1)

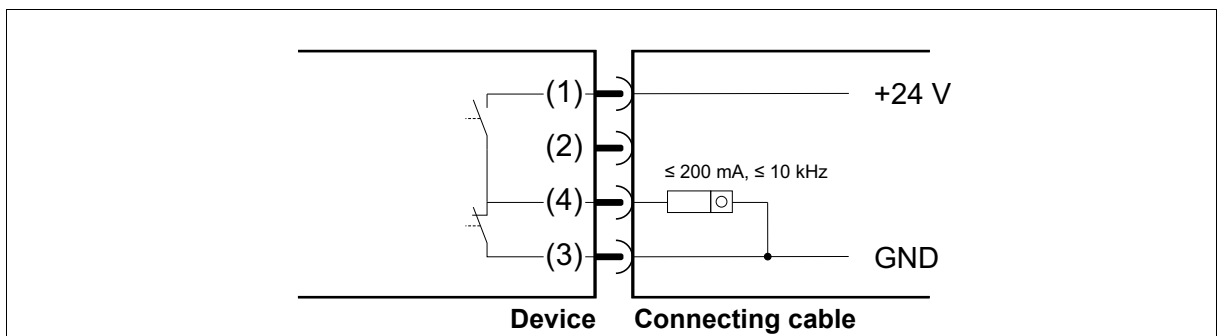

7 Electrical connection

Pulse output – push-pull (example 2)

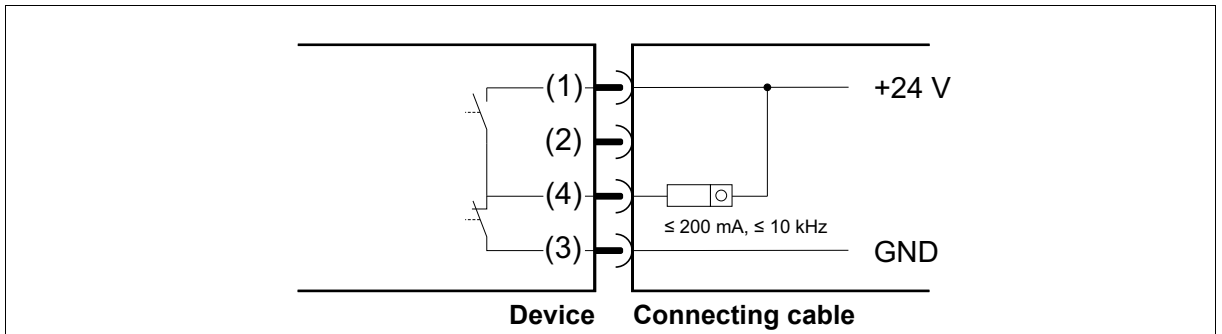

Pulse output – NPN (optionally)

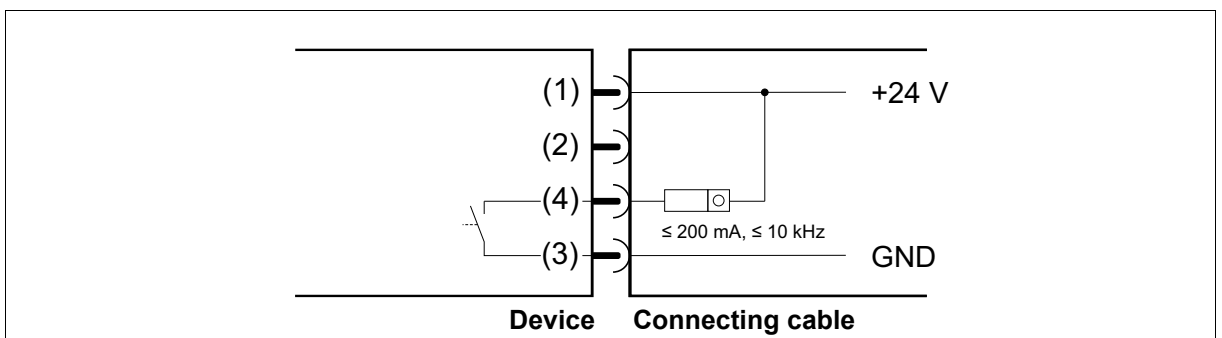

Pulse output – PNP (optionally)

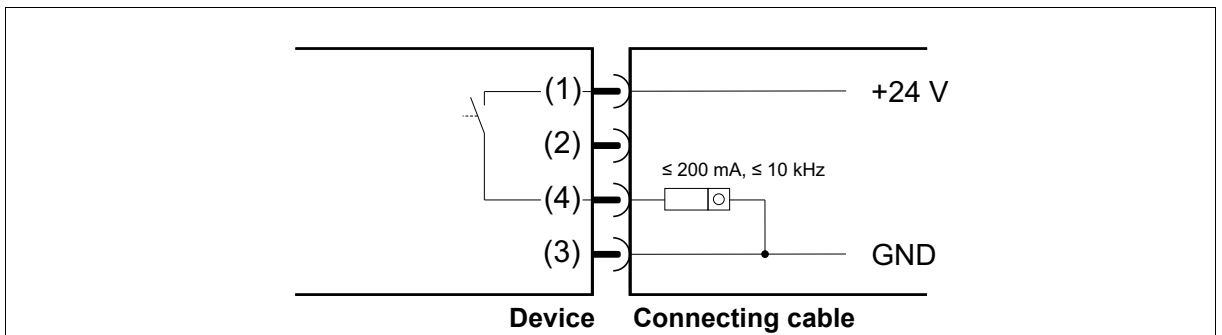

7.2 Connecting the device

1. Insert the connecting cable into the M12 plug connection.

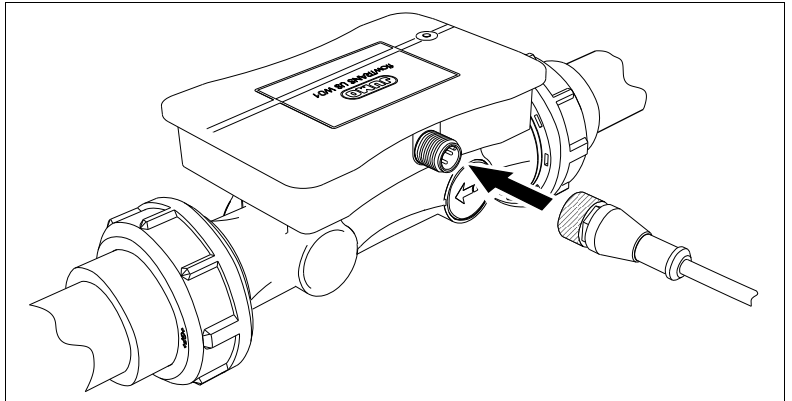

2. Manually screw the union nut of the connecting cable onto the M12 plug connection on the device.

If you are using the connecting cable provided by the manufacturer, tighten the union nut using an open-end wrench AF 13.

Maximum tightening torque:
0.4 Nm.

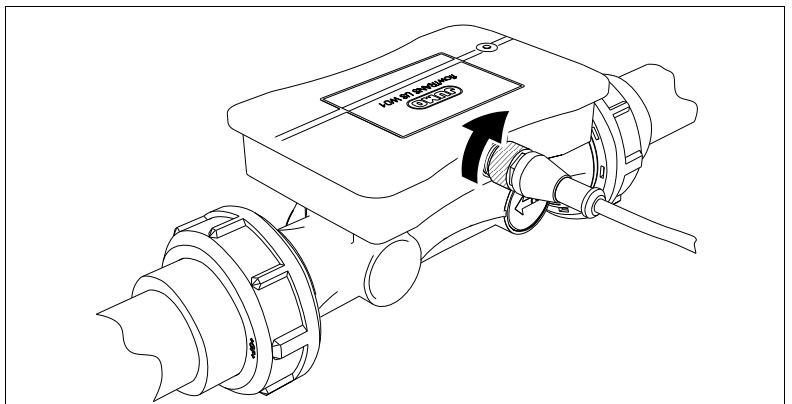

3. Connect the connecting cable to the device that is processing the signals and to the voltage supply. Route the cable so that it is protected against mechanical strain.

The device is ready for use. The device status LED indicates the current status of the device ⇒ "Display and control elements", Page 22.

8 Operation

8.1 Display and control elements



(1) Multicolored device status LED

8.2 Troubleshooting

The device status is indicated by a multicolored LED (red/green/yellow).

LED signal	Device status (error message)	Status signal according to NAMUR
Green (f = 1 Hz, $t_{on}/T = 0.9$)	0 = normal operation	-
Red (f = 1 Hz, $t_{on}/T = 0.5$)	1 = error	F
Yellow (f = 1 Hz, $t_{on}/T = 0.5$)	2 = outside the specification	S
Red (f = 5 Hz, $t_{on}/T = 0.5$)	4 = failure (serious error)	F
Yellow	Initialization phase	C

Error message	Device function	Possible cause	Troubleshooting
0	All	No errors	-
2	Input for volume flow	Volume flow > MRE	Reduce the plant's volumetric flow Use larger device nominal width
		Partial filling/empty conduit	Fill pipe
		Gas bubbles in the medium > level 1 (measurement still possible)	Bleed the system Increase the system pressure
2	Analog output	Burden too high	Check electrical connection
2	Digital output	Short circuit in output due to overload	Check electrical connection
4	General information	Checksum of configuration data faulty	Contact manufacturer
		General error	
4	Input for volume flow	Volume flow invalid	Contact manufacturer
		Gas bubbles in the medium > level 2 (measurement no longer possible)	

9.1 Cleaning device housing

The device housing can be cleaned when the device has been installed.

Clean the device with a cloth dampened with water.

9.2 Cleaning parts that come into contact with the medium and replacing O-rings

Requirements:

- Uninstall the device ⇒ "Uninstalling the device", Page 24.
- Wear suitable protective equipment.
- Provide a cleaning area for flushing all parts that come into contact with the medium.

1. **CAUTION!** Do not damage the sealing ring grooves of the process connections when removing the O-rings.

Remove the O-rings from the sealing ring grooves of the process connections.

2. Flush all parts that come into contact with the medium thoroughly with water.
3. Check the O-rings for damage and replace them if necessary.
4. Insert the O-rings into the sealing ring grooves of the two process connections.
5. Install the device ⇒ "Installing the device", Page 17.

9.3 Decontaminating the device

Requirements:

- Uninstall the device ⇒ "Uninstalling the device", Page 24
- Wear suitable protective equipment.
- Have a suitable cleaning agent ready.
- Provide a cleaning area for flushing and neutralizing all parts that come into contact with the medium according to the safety data sheet for the hazardous substance.

1. **CAUTION!** Do not damage the sealing ring grooves of the process connections when removing the O-rings.

Remove the two O-rings from the sealing ring grooves.

2. **CAUTION!** Use only cleaning agents that are compatible with the materials used to make the device. Thoroughly flush and neutralize all parts that come into contact with the medium using a suitable cleaning agent according to the safety data sheet for the hazardous substance.
3. In the event of disposal: ⇒ "Disposal", Page 24.
4. In the event of continued use: Check the O-rings for damage and replace them if necessary.
5. Insert the O-rings into the sealing ring grooves of the two process connections.
6. Install the device ⇒ "Installing the device", Page 17.

10 Shutdown

10.1 Uninstalling the device

Requirements:

- Switch off the plant's voltage and secure it so that it cannot switch on again.
- Stop medium circulation in the plant.
- Drain and flush the pipe.
- Wear suitable protective equipment.
- Provide a clean and dry storage area.

1. Manually loosen the union nut of the connecting cable from the M12 plug connection on the device.
If you are using the connecting cable provided by the manufacturer, loosen the union nut using an open-end wrench AF 13.
2. Pull the connecting cable out of the M12 plug connection and remove from the working area.
3. Manually loosen the union nuts from the process connections on the device and slide over the ends of the pipe.
4. **CAUTION!** Make sure that the O-rings remain in the sealing ring grooves of the process connections of the device.
Carefully remove the device from the plant and put in a clean and dry place.

10.2 Returning devices

Requirements:

- Clean the device housing ⇒ "Cleaning device housing", Page 23.
 - Clean the parts that come into contact with the medium ⇒ "Cleaning parts that come into contact with the medium and replacing O-rings", Page 23.
 - Decontaminate the device ⇒ "Decontaminating the device", Page 23.
1. The [supplementary sheet for product returns \(http://productreturn.jumo.info\)](http://productreturn.jumo.info) must first be completed correctly and signed. Then enclose it with the shipping documents and attach it to the packaging, ideally on the outside.
 2. Use the original packaging or a suitably secure container for sending the device.

10.3 Disposal

Requirements:

- Clean the device housing ⇒ "Cleaning device housing", Page 23.
- Clean the parts that come into contact with the medium ⇒ "Cleaning parts that come into contact with the medium and replacing O-rings", Page 23.
- Decontaminate the device ⇒ "Decontaminating the device", Page 23.



DISPOSAL

Devices and/or replaced parts should not be placed in the trash at the end of their service life as they consist of materials that can be recycled by specialist recycling plants.

Dispose of the device and the packaging material in a responsible and environmentally friendly manner. For this purpose, observe the country-specific laws and regulations for waste treatment and disposal.

11 Accessories

Product name	Part no.
Installation accessories	
Mounting set PVC DN 15 with PP-Nut	00750871
Mounting set PVC DN 20 with PP-Nut	00750872
Mounting set PVC DN 25 with PP-Nut	00750874
Mounting set PVC DN 32 with PP-Nut	00750876
Mounting set PP socket-welding DN 15	00750888
Mounting set PP socket-welding DN 20	00750890
Mounting set PP socket-welding DN 25	00750927
Mounting set PP socket-welding DN 32	00750926
Mounting set PP butt-welding DN 15	00750878
Mounting set PP butt-welding DN 20	00750881
Mounting set PP butt-welding DN 25	00750884
Mounting set PP butt-welding DN 32	00750887
Mounting set stainless steel DN 15 with PP-Nut	00750923
Mounting set stainless steel DN 20 with PP-Nut	00750920
Mounting set stainless steel DN 25 with PP-Nut	00750919
Mounting set stainless steel DN 32 with PP-Nut	00750918
Mounting set PVC DN 10 with PP-Nut	00750869
Mounting set stainless steel DN 10 with PP-Nut	00750924
Connecting cable for plug connector M12	
Cable socket, straight, 4-pole, M12 × 1, 2m	00404585
Cable socket, angled, 4-pole, M12 × 1, 2m	00409334

12 China RoHS

						
产品组别 Product group: 406050	产品中有害物质的名称及含量 China EEP Hazardous Substances Information					
部件名称 Component Name						
	铅 (Pb)	汞 (Hg)	镉 (Cd)	六价铬 (Cr(VI))	多溴联苯 (PBB)	多溴二苯醚 (PBDE)
外壳 Housing (Gehäuse)	○	○	○	○	○	○
过程连接 Process connection (Prozessanschluss)	○	○	○	○	○	○
螺母 Nuts (Mutter)	○	○	○	○	○	○
螺栓 Screw (Schraube)	○	○	○	○	○	○
<p>本表格依据SJ/T 11364的规定编制。 This table is prepared in accordance with the provisions SJ/T 11364. ○ : 表示该有害物质在该部件所有均质材料中的含量均在GB/T 26572规定的限量要求以下。 Indicate the hazardous substances in all homogeneous materials for the part are below the limit of the GB/T 26572.</p> <p>× : 表示该有害物质至少在该部件的某一均质材料中的含量超出GB/T 26572规定的限量要求。 Indicate the hazardous substances in at least one homogeneous material of the part exceed the limit of the GB/T 26572.</p>						

JUMO

OneTemp[®] pty ltd
measure | control | record
1300 768 887
www.onetemp.com.au

