

# LPN-H Humidity and Temperature Transmitter

The LPN-H has two independent, 2 wire, 4~20mA loop powered outputs:  
One for relative Humidity;  
One for Temperature.

## Features.

- Dual 4~20mA Outputs.
- Sensirion SHT25 Digital Humidity sensor - Factory calibrated.
- Long term stability.
- Fast response: 4 seconds from 0 to 100%RH under ideal conditions.
- Pt100 RTD Temperature Sensor.
- Temperature Output Linearised.
- Very Compact Design.
- High Accuracy.
- Low Cost.
- Easy to Install.
- Reverse Polarity Protection.
- Wide Power Supply Range.
- Rugged and reliable.



## Description.

The LPN-H is a complete relative humidity and temperature current loop sensing module, with two independent loop powered 4~20mA outputs, one for Humidity (0~100%RH) and one for temperature (0~100°C).

Two versions are available:

- Wall Mount (**LPN-H-W**).
- Duct Mount (**LPN-H-D**).

Both versions come complete in an industrial standard aluminium connection head. The digital relative Humidity sensor and Temperature sensor protrude from the head inside a protective cap. This cap allows air to circulate to the sensors while protecting them from physical harm.

## Ordering Information.

**LPN-H-W** Wall Mount, 0~100%RH, 0~100°C Transmitter.

**LPN-H-D** 220mm Duct Mount, 0~100%RH, 0~100°C Transmitter.

**LPN-H-F** 100mm Flange for LPN-H-D.

Note: 0~200°F temperature output optional. Please specify when ordering.

## Quality Assurance Programme.

The modern technology and strict procedures of the Quality Assurance Programme applied during design, development, production and final inspection grant the long term reliability of the instrument.

## LPN-H Common Specifications.

Output	2 wire 4~20mA (Loop Powered).
Power Supply	9~33Vdc.
Supply Voltage Sensitivity	<±0.01%/V FSO.
Maximum Output Current	Limited to <32mA.
Max output Load Resistance	800Ω @ 24Vdc. (50Ω/V Above 8Vdc).
Isolation Test Voltage	Between %RH and Temperature; 50Vdc for 1 min.
Operating Temperature	-30~70°C.
Storage Temperature	-30~85°C.
Operating Humidity	100%RH. Non-condensing.
IP Rating	Sensor = IP51, Terminal Case = IP68. See Note 2 on page 2.

## LPN-H %RH Transmitter Specifications.

Accurate to		±2% FSO Typical 10~80%RH non condensing.
	-Important	For continuous measurements of ≥90%RH, refer to operating range on next page.
Ambient Temperature Drift		<±0.05%/C FSO Typical.
Humidity Sensor	-Hysteresis	±0.8% of Span Typical.
	-Linearity	±0.5%RH Typical.
	-Repeatability	±0.5%RH Typical.
	-Long Term Drift	±1%RH Typical at 50%RH in 5 years.
	-Output	0~100%RH for 4~20mA.

## LPN-H Temperature Transmitter Specifications.

Accurate to		<±0.1% FSO Typical + sensor Error.
Linearity and Repeatability		<±0.1% FSO Typical + sensor Error.
Ambient Temperature Drift		<±0.02%/C FSO Typical + sensor Drift.
RTD Sensor		Pt100 RTD, Class A Din 43760, IEC60751.
Sensor Current		1.0mA.
Sensor Output		0~100°C for 4~20mA factory calibrated. Output will stay at 4mA or 20mA if temperature low or high. 3mA output indicates faulty sensor.

**Note 1:** The inside of the head with the electronics board must not get wet.

**Note 2:** Good airflow and good air mixing must be maintained over the sensor to minimise local temperature fluctuations, and to ensure accurate measurements.

CONDENSATION occurs whenever the surface temperature of the sensor's active area drops below the ambient dew point of the surrounding gas. Condensation forms on the sensor (or any surface), even if the surface temperature only momentarily drops below the ambient dew point. Small temperature fluctuations near the sensor can unknowingly cause condensation to form when operating at humidity levels above 90%. While quick to condense, water is slow to evaporate in high humidity conditions. (I.e. when the surface temperature of the sensor is only slightly above the ambient dew point). Because of this, a sensor's recovery from either condensation or wetting is much longer than its normal time response.

During recovery, the sensor outputs a constant 100%RH signal, regardless of the ambient RH.

### LPN-H-W Dimensions.

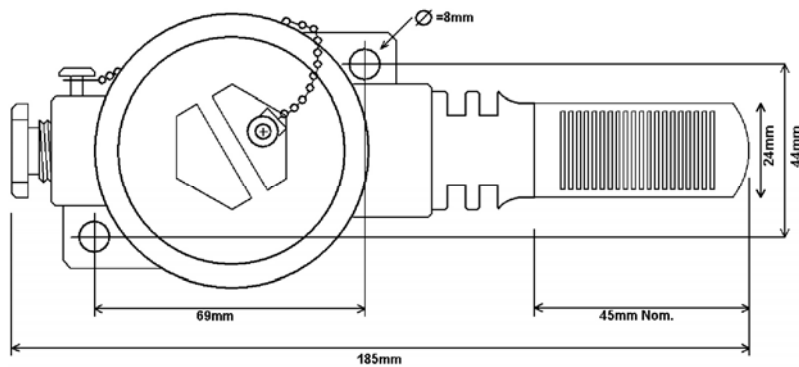

### LPN-H-F Dimensions.

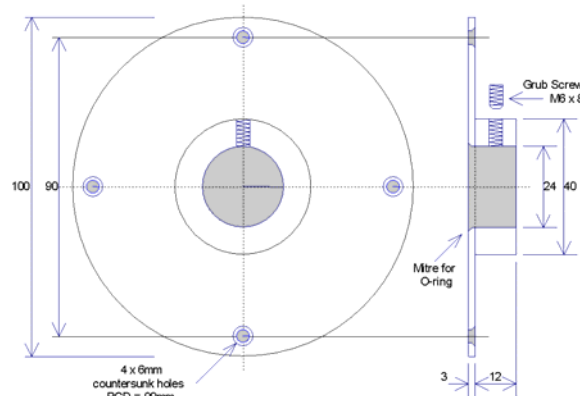

### LPN-H-D Dimensions.

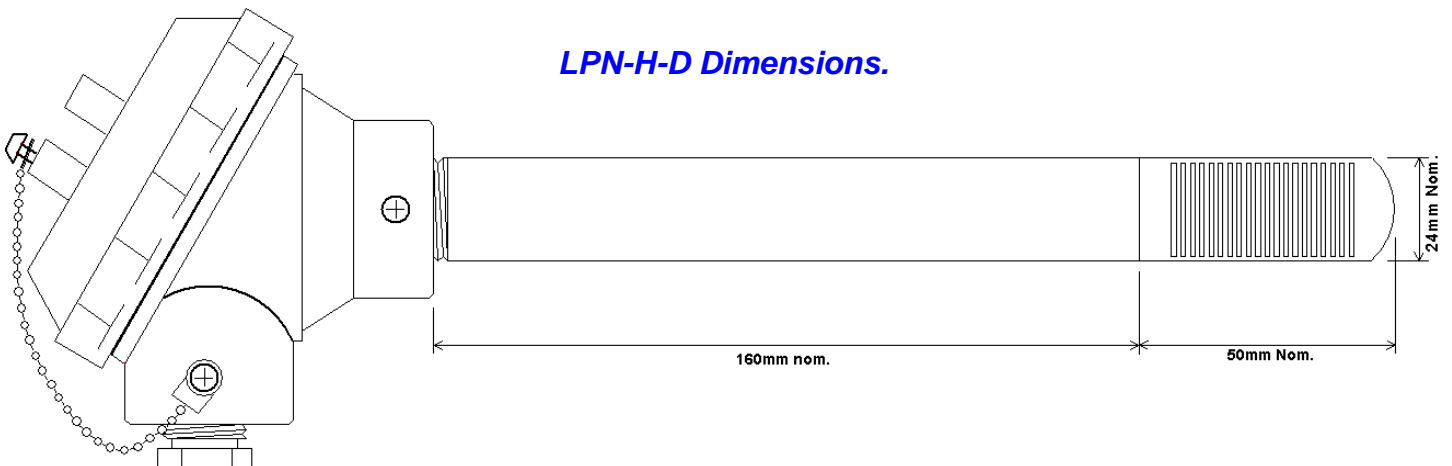

### Humidity Sensor Operating Range.

The sensor used in this Transmitter is a Sensirion SHT25. This sensor is fully calibrated at Sensirion. A Sensirion Calibration certificate is available from their web site: [www.sensirion.com](http://www.sensirion.com)

The sensor is stable within the recommended Normal Range. Long term exposure to conditions outside the Normal Range, especially at humidity >80%RH, may temporarily offset the RH signal (+3%RH after 60h). After returning into the Normal Range it will slowly return towards calibration state by itself.

**Graph of Relative Humidity Versus Temperature.**

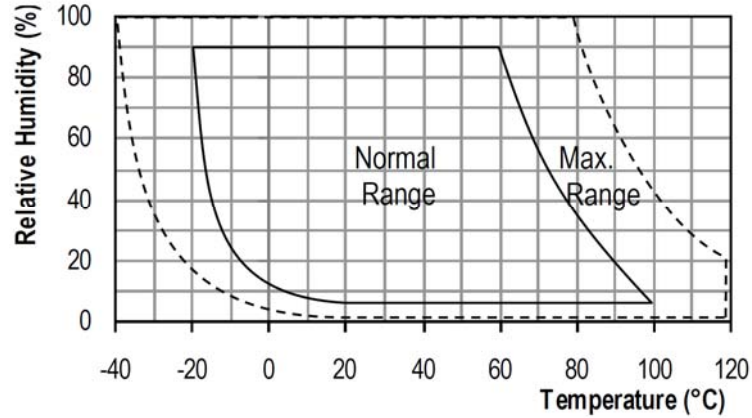

**Graph of Maximum Load Versus Power Supply.**

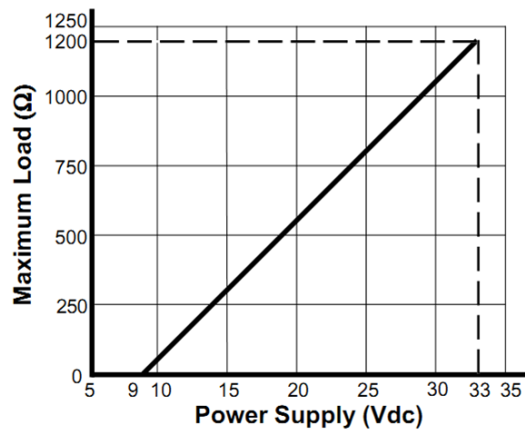

**LPN-H Connection Example.**

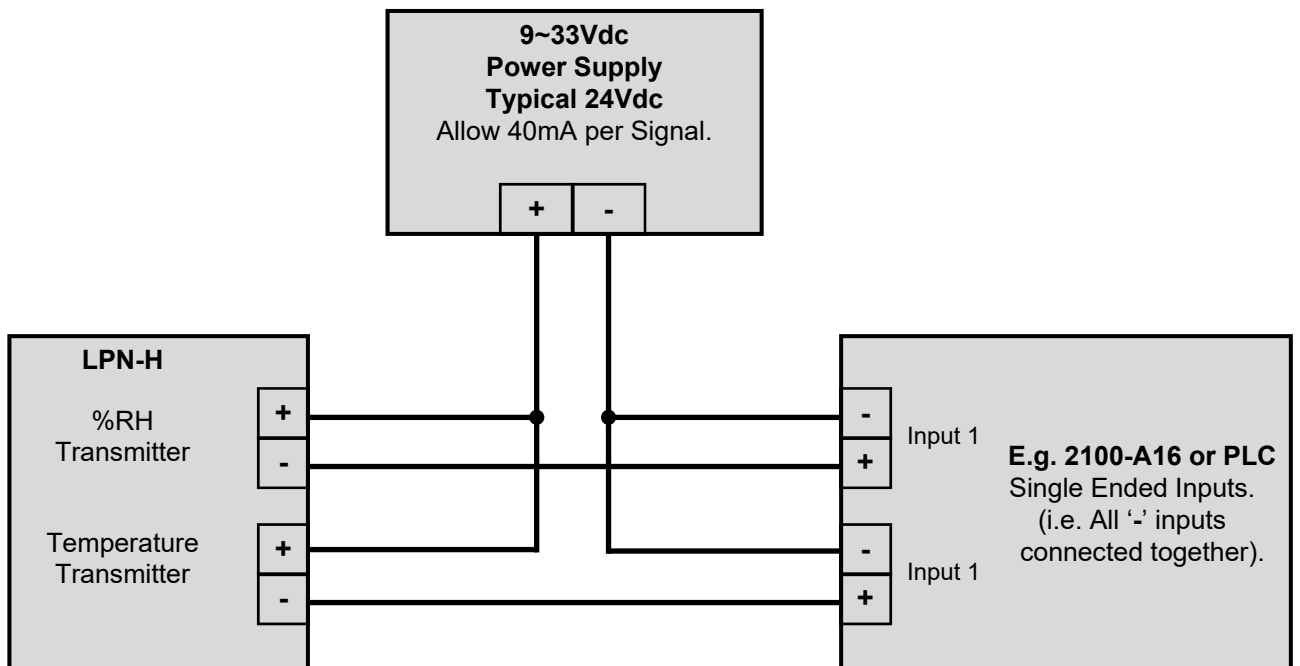

## The Proper Installation & Maintenance of LPN-H.

All power and signals must be de-energised before connecting any wiring.

### Mounting.

- (1) Mount in a clean environment.
- (2) Do not subject to vibration.
- (3) Avoid mounting near power control equipment.
- (4) Mount the LPN-H-W on a solid wall or panel, where air will flow freely around it.
- (5) Mount the LPN-H-D through a LPN-H-F 100mm flange, into the duct.
- (6) Always mount the LPN-H so that the protective cap is either horizontal or sloping downwards. This helps prevent condensate build up in high humidity situations.
- (7) Avoid mounting where the protective cap will get wet as this may cause false readings.
- (8) Again ensure there is adequate air flow over the sensor.
- (9) To maintain compliance with the EMC Directives, the LPN-H metal enclosure must be properly earthed, with appropriate input / output entry points, cabling and filtering.

### Wiring.

- (1) All cables should be good quality overall screened INSTRUMENTATION CABLE with the screen earthed at one end only.
- (2) Signal cables should be laid a minimum distance of 300mm from any power cables.
- (3) For the two, 2 wire current loops Austral Standard Cables B5002CS is recommended.
- (4) It is recommended that you do not ground current loops and use power supplies with ungrounded outputs.
- (5) Lightning arrestors should be used when there is a danger from this source.
- (6) Refer to diagrams for connection information.

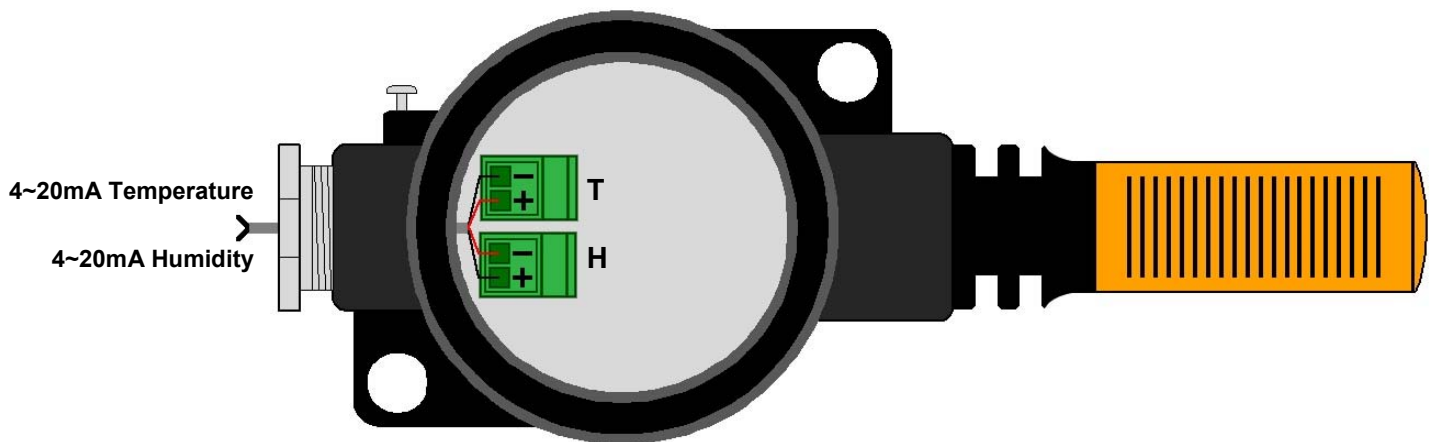

### Commissioning.

- (1) Once all the above conditions have been carried out and the wiring checked apply power to the LPN-H loops and allow five minutes for them to stabilize.
- (2) To check humidity accuracy use a calibration standard %RH device in the same location. Check that the readings agree within 2% + error of the calibration device. Alternatively expose the LPN-H to a known %RH atmosphere, and check the readings agree within 2% + % error of atmosphere. All readings should be referenced against the ASTM Relative Humidity tables, and allowances made for pressure effects if necessary. If there is a problem with the Humidity reading the unit will need to be returned for recalibration.
- (3) To check temperature accuracy place the unit into a temperature chamber. Remove the protective cap (as below) and place the calibration device sensor close to the LPN-H sensor. Check that the readings agree within 0.1% + sensor error + error of the calibration device. If there is a problem with the Temperature reading the unit will need to be returned for recalibration.

### Maintenance.

- (1) Breathe on the protective cap and check that the %RH and Temperature readings alter.
- (2) Do it regularly - at least once every 6 months.
- (3) Check cables entering the LPN-H head.

### Cleaning or Replacing the Protective Cap.

If the protective cap becomes dirty it can easily be removed for cleaning, or replaced, as follows:

- (1) Disconnect power from LPN-H.
- (2) Carefully unscrew the cap by hand. No tools to be used - they may damage the protective cap.
- (3) The cap may now be cleaned or replaced.
- (4) Ensure the cap is thoroughly dry before replacing.
- (5) Carefully screw the cap back on by hand, and reapply the power to the LPN-H

NOTE: The LPN-H can be operated without the protective cap, as the humidity sensor reading is not affected by light. Prolonged direct exposure to sunshine or strong UV radiation may age the sensor. The sensors are easily damaged without the protective cap.

**Product Liability.** This information describes our products. It does not constitute guaranteed properties and is not intended to affirm the suitability of a product for a particular application. Due to on-going research and development, designs, specifications, and documentation are subject to change without notification. Regrettably, omissions and exceptions cannot be completely ruled out. No liability will be accepted for errors, omissions or amendments to this specification. Technical data are always specified by their average values and are based on Standard Calibration Units at 25C, unless otherwise specified. Each product is subject to the 'Conditions of Sale'.

**Warning: These products are not designed for use in, and should not be used for patient connected applications. In any critical installation an independent fail-safe back-up system must always be implemented.**