

## Adding a Sensor Node to the HOBOnet Wireless Sensor Network

**Important:** Keep the sensor node near the station while completing these steps.

If you are setting up a new station, follow the instructions in the station quick start guide before setting up this sensor node (go to [www.onsetcomp.com/resources/documentation/24380-man-rx2105-rx2106-qsg](http://www.onsetcomp.com/resources/documentation/24380-man-rx2105-rx2106-qsg) for RX2105 and RX2106 stations or [www.onsetcomp.com/resources/documentation/18254-man-qsg-rx3000](http://www.onsetcomp.com/resources/documentation/18254-man-qsg-rx3000) for RX3000 stations).

1

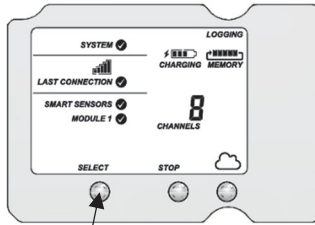

Press the Select button on the station to switch to the module with the manager (module 2 on RX2105 or RX2106 stations).

2

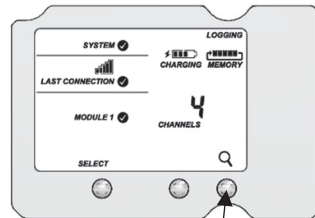

Press the Search button. The magnifying glass icon will blink while the station is in search mode waiting for sensor nodes to join the network.

3

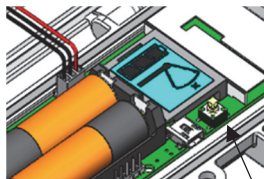

Open the sensor node door and install the rechargeable batteries. Press this button on the sensor node for 3 seconds.

4

Watch the sensor node LCD during the process of joining the network:



This signal strength icon blinks while searching for a network.



Once a network is found, the icon will stop flashing and the bars will cycle from left to right.



This network connection "x" icon blinks while the sensor node completes the registration process, which may take up to five minutes.



Once the sensor node has finished joining the network, the "x" icon is removed and the channel count on the station LCD increases by four (three for wind speed, direction, and gust speed, and one for the sensor node battery).

5

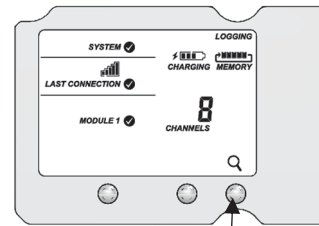

Press the Search button on the station again to stop the search for sensor nodes.

6



Go to [www.hobolink.com](http://www.hobolink.com) to monitor sensor node status and health. See the HOBOLink Help for details.

1

Orient the bracket so the text TOP is facing upwards.

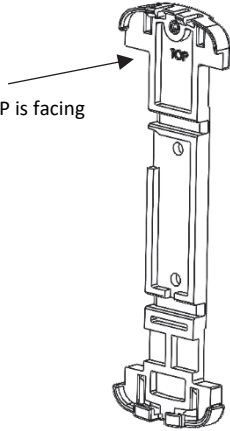

2

To install the bracket onto a wall, use the two long screws included in the package. Screw the bracket to a wall using the two holes on the mid-section of the bracket.

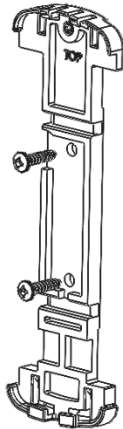

3

To install the bracket onto a pole, slip a cable tie through each of the channels on the bracket and fasten the tie around the pole.

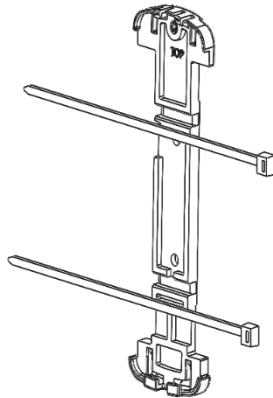

4

Insert the bottom of the sensor node into the retaining clips on the bottom of the bracket then press the top of the sensor node into the clips at the top of the bracket.

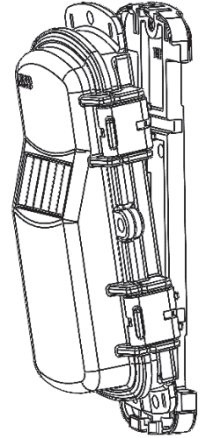

5

Use the short screw included in the package to fasten the sensor node to the bracket.

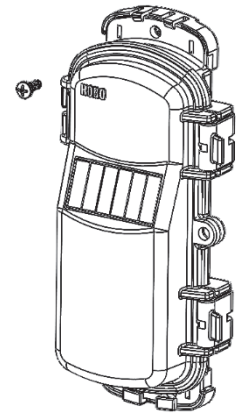

6

Close the sensor node and use a padlock to keep it secure.

**Note:** Ensure that the node seal is clean from foreign debris.

---

## Mounting and Positioning the Sensor Node

Position the sensor node towards the sun, making sure the solar panel is oriented so that it receives optimal sunlight throughout each season. It may be necessary to periodically adjust the sensor node position as the path of the sunlight changes throughout the year or if tree and leaf growth alters the amount of sunlight reaching the solar panel.

Make sure the sensor node is mounted a minimum of 1.8 m (6 feet) from the ground or vegetation to help maximize distance and signal strength.

Consider using plastic poles such as PVC to mount the sensor node as certain types of metal could decrease the signal strength.

Place the sensor node so there is full line of sight with the next sensor node. Use a repeater if there is an obstruction between sensor nodes.

There should not be more than five sensor nodes in any direction from a repeater or the manager. Data from sensor nodes travels or “hops” across the network and may not reach the station if the sensor node is more than five hops away.

---

## Sensor Mounting Guidelines

- The sensor can be damaged with improper handling. Store the sensor in its shipping box until you are ready to install it.
  - To ensure correct orientation of the wind vane, the sensor must be mounted so that the anemometer arm points north (see the product manual for details).
  - Mount the sensor 2 m (7 ft) or more above the ground and at least 2.1 m (7 ft) above the roof line if mounted on a roof and mounted at a distance of at least five times the height of the nearest tree, building, or other obstruction.
  - The sensor should be mounted vertically in a location free of wind shadows.
  - Secure the sensor cable with cable ties to protect it.
  - The tripod or mounting mast must be properly grounded. Use the grounding kit (M-GKA).
  - Installing a lightning rod to reduce the risk of damage if the sensor is located in an area with frequent thunderstorms.
  - Use the guy wire kit (M-GWA) to secure the mast where the wind sensor is mounted so that it does not vibrate.
  - To minimize measurement errors due to ambient RF, keep the probe cable as far as possible from other cables carrying high frequency or high-current signals.
- 

## Assembling and Mounting the Sensor

1. Slide the wind vane onto the wind vane shaft. The wind direction has been calibrated in the factory so that it will be correct when the arm is installed pointing north and the vane is installed correctly.
2. Tighten the set screw in the wind vane with the Allen wrench.
3. Push the wind cups onto the anemometer’s stainless steel wind cup shaft.
4. Slide the wind cups up the shaft as far as possible.
5. Use the Allen wrench to tighten the set screw on the side of the wind cups. The cups should drop slightly when you let go.
6. Ensure the set screw is screwed in fully and very tight. Failure to do so will cause the anemometer to function improperly. Make sure the cups spin freely.
7. Insert the anemometer arm into the base, sliding the cable through the notch in the base as shown below. Be sure to line up the small hole in the arm with the holes in the base.
8. Insert the machine screw through the holes in the base and arm.
9. Slide the tooth-lock washer and hex nut onto the machine screw. Tighten the hex nut while holding the screw with a Phillips head screwdriver to prevent it from turning.

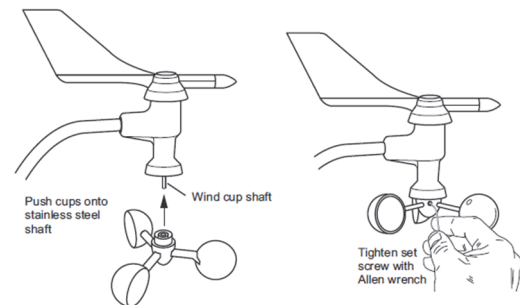

10. Press the sensor cable firmly and completely into the zig-zagging channel in the base, starting from the arm and progressing downward to the bottom of the base.

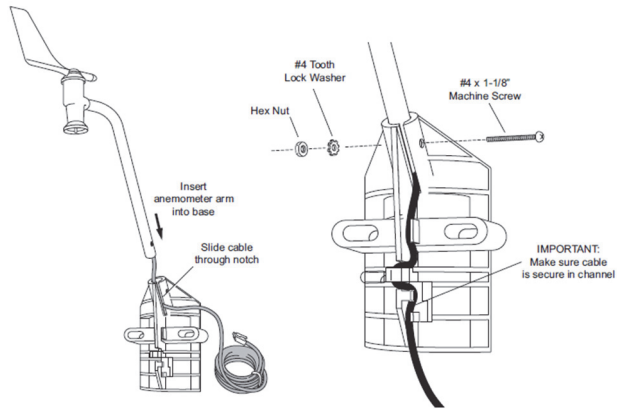

11. To mount the sensor on a tripod or mast, place the U-bolt around the pole so that its two ends extend through the holes in the mounting base. Loosely secure with the flat washers, lock washers, and hex nuts.

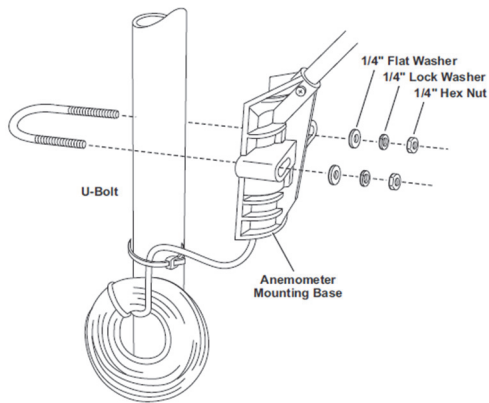

12. Raise the anemometer to the desired height on the pole and swivel it so the anemometer arm is pointing north.

13. Using an adjustable wrench or 7/16 inch wrench, tighten the hex nuts until the anemometer is firmly fastened on the pole.



For specifications, complete mounting guidelines, and other details about this sensor node, refer to the full product manual. Scan the code at left or go to: [www.onsetcomp.com/resources/documentation/22245-rxw-wcf-manual](http://www.onsetcomp.com/resources/documentation/22245-rxw-wcf-manual)