

Dairy Industry

RM-H Triclover

Triclover Measurement

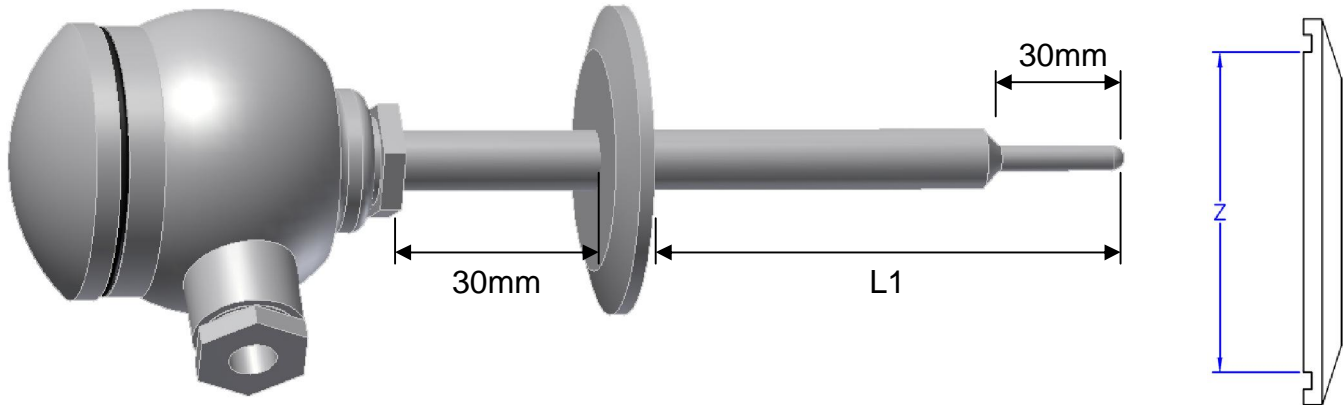

Order Code	Length L1	Triclover Z
RM-H-TRI-50-1T-PSS	50mm	1"
RM-H-TRI-100-1T-PSS	100mm	1"
RM-H-TRI-50-15T-PSS	50mm	1.5"
RM-H-TRI-100-15T-PSS	100mm	1.5"
RM-H-TRI-50-2T-PSS	50mm	2"
RM-H-TRI-100-2T-PSS	100mm	2"
RM-H-TRI-50-25T-PSS	50mm	2.5"
RM-H-TRI-100-25T-PSS	100mm	2.5"

RM-H Triclover probes are supplied with a 12.7mm OD shaft for extra support. Also a 30 x 5.5mm OD reduced tip is fitted for faster response. A Bakelite terminal block is housed in a machined and polished 316 Stainless head. Pt100 Class A RTD element is standard. All wetted parts are machined and polished for use in food applications.

RM-H BSM

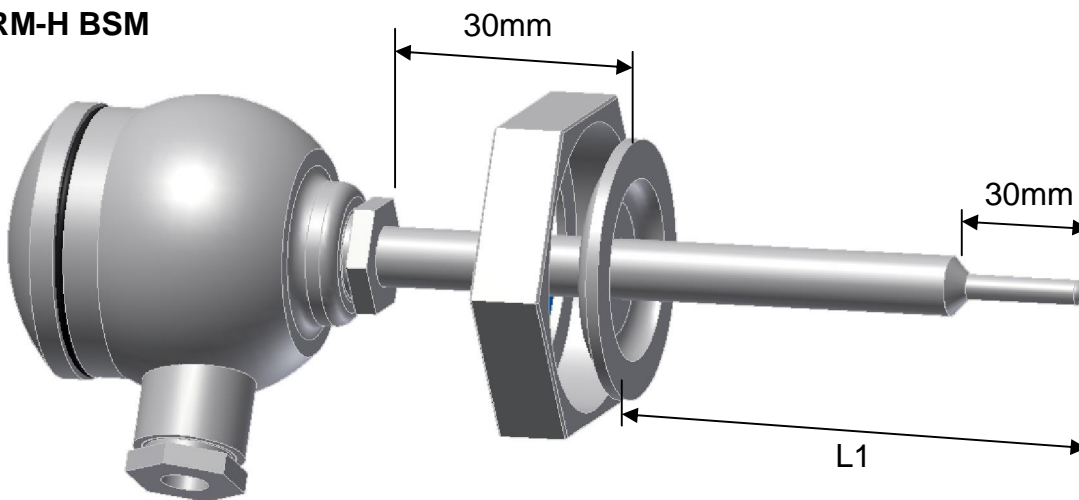

Order Code	Length L1	BSM
RM-H-BSM-50-1B-PSS	50mm	1"
RM-H-BSM-100-1B-PSS	100mm	1"
RM-H-BSM-50-15B-PSS	50mm	1.5"
RM-H-BSM-100-15B-PSS	100mm	1.5"
RM-H-BSM-50-2B-PSS	50mm	2"
RM-H-BSM-100-2B-PSS	100mm	2"
RM-H-BSM-50-25B-PSS	50mm	2.5"
RM-H-BSM-100-25B-PSS	100mm	2.5"

RM-H BSM probes are supplied with a 12.7mm OD shaft for extra support. Also a 30 x 5.5mm OD reduced tip is fitted for faster response. A Bakelite terminal block is housed in a machined and polished 316 Stainless head. Pt100 Class A RTD element is standard. All wetted parts are machined and polished for use in food applications.