

JUMO miroTRON

Electronic thermostat with PID two-state controller function



Brief Instructions



70109000T97Z000K000

V1.00/EN/2022-12-01

Further information and downloads



qr-701090-en.jumo.info

1	Safety	5
1.1	Symbols and signal words	5
1.2	Intended use	5
1.3	Safety information	6
1.4	Qualification of personnel	6
1.5	Supplementary technical documentation	7
2	Description	8
2.1	General overview	8
2.2	Brief description	8
2.3	Identifying the device version	9
2.3.1	Nameplate	9
2.3.2	Order details	10
2.3.3	Scope of delivery	10
2.3.4	Accessories	10
3	Acceptance of goods, storage, and transport	11
3.1	Checking the delivery	11
3.2	Important information about storage and transport	11
3.3	Returning goods	11
3.4	Disposal	12
4	Mounting	13
4.1	Installation instructions	13
4.2	Dimensions	14
4.2.1	Type 701090	14
4.2.2	Type 701091	15
4.2.3	Installation dimensions	15
4.3	Panel mounting	16
5	Electrical connection	17
5.1	Installation notes	17
5.2	Connection elements and connectors	18
5.3	Connection diagram	19
5.3.1	Type 701090 (Ø 60) and Type 701091 (Ø 80)	19
5.4	Galvanic isolation	20
6	Operation	21
6.1	Display and control elements	21
6.1.1	Operating overview	22
6.2	Language selection	22

Contents

7	Maintenance, cleaning, troubleshooting	24
7.1	Maintenance	24
7.2	Cleaning	24
7.3	Troubleshooting	24
7.3.1	Types of errors	24
7.3.2	Error messages	24
8	Technical data	25
8.1	Analog input	25
8.2	Digital input	25
8.3	Digital output	25
8.4	Display	26
8.5	Electrical data	26
8.6	Environmental influences	27
8.7	Housing	27
8.8	Approvals and approval marks	27

1.1 Symbols and signal words

General

This manual contains information that must be observed in the interest of your own safety and to avoid material damage. This information is supported by symbols which are used in this manual as indicated.

Please read this manual before starting up the device. Store this manual in a place that is accessible to all users at all times.

If difficulties occur during startup, please do not intervene in any way that could jeopardize your warranty rights!

Warning symbols



DANGER!

This symbol indicates that **personal injury from electrocution** may occur if the appropriate precautionary measures are not taken.



WARNING!

This symbol in connection with the signal word indicates that **personal injury** may occur if the respective precautionary measures are not carried out.



CAUTION!

This symbol in connection with the signal word indicates that **material damage or data loss** will occur if the respective precautionary measures are not taken.



CAUTION!

This symbol indicates that **components could be destroyed** by electrostatic discharge (ESD = Electro Static Discharge) if the respective cautionary measures are not taken.

Only use the ESD packages intended for this purpose to return device inserts, assembly groups, or assembly components.

Note symbols



NOTE!

This symbol refers to **important information** about the product, its handling, or additional benefits.



FURTHER INFORMATION!

This symbol is used in tables and indicates that **further information** is provided after the table.



DISPOSAL!

At the end of its service life, the device and any batteries present do not belong in the trash! Please ensure that they are **disposed of** properly and in an **environmentally friendly** manner.

1.2 Intended use

The device is designed for use in an industrial environment as specified in the technical data. Other uses beyond those defined are not viewed as intended uses.

1 Safety

The device has been manufactured in compliance with applicable standards and directives as well as the applicable safety regulations. Nevertheless, improper use may lead to personal injury or material damage.

To avoid danger, only use the device:

- For the intended use
- When in good order and condition
- When taking the technical documentation provided into account

Risks resulting from the application may arise, e.g. as the result of missing safety provisions or wrong settings, even when the device is used properly and as intended.

1.3 Safety information



DANGER!

Risk to life due to electric shock

Risk of injury when touching live parts!

- ▶ Only qualified electricians are allowed to connect and install an electrical device that is not already ready to use.
 - ▶ Before working on the system or device, switch off the voltage and secure it so that it cannot switch on again.
 - ▶ Do not touch electronic components when they are live.
 - ▶ Always observe the relevant accident prevention regulations and safety requirements for electrical devices.
-



CAUTION!

Risk of device damage

If the device is not supplied with the voltage specified on the nameplate, this could cause damage to the device.

- ▶ Only supply voltage from a voltage source that matches the specifications on the nameplate.
-



CAUTION!

The front of the device and housing have different protection types!

The protection type IP65 (front-side) is only guaranteed if the seal is flush and even.

- ▶ Use the mounting frame or both mounting elements as shown in the figure and ensure an even attachment!
-

1.4 Qualification of personnel

This document contains the necessary information for the intended use of the device to which it relates.

It is intended for staff with technical qualifications who have been specially trained and have the appropriate knowledge in the field of automation technology.

The appropriate level of knowledge and the technically fault-free implementation of the safety information and warnings contained in the technical documentation provided are prerequisites for risk-free mounting, installation, and startup as well as for ensuring safety when operating the described modules. Only qualified personnel have the required specialist knowledge to correctly interpret and implement the safety information and warnings contained in this document in specific situations.

1.5 Supplementary technical documentation

In addition to these brief instructions, a detailed operating manual is available for download as a PDF document (see QR code and web link in this document).

The operating manual contains additional information on the device, in particular on operation and configuration.

2 Description

2.1 General overview

The device is available in the following versions:

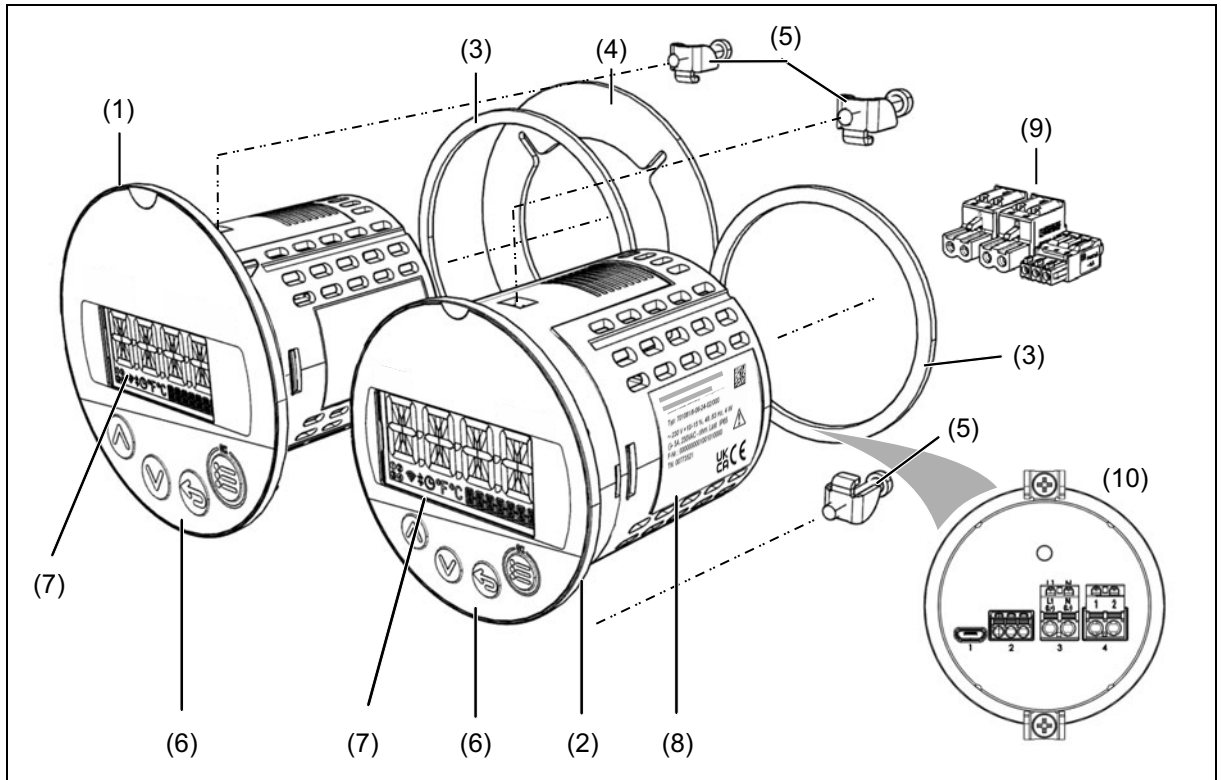

1	Type 701091, front panel 88 mm	2	Type 701090, front panel 68 mm
3	Seal	4	Adapter plate
5	Panel fasteners	6	Front panel with membrane keyboard, chapter 6.1 "Display and control elements", Page 21
7	Display	8	Nameplate, chapter 2.3.1 "Nameplate", Page 9
9	Pluggable terminal strips	10	Rear view with pluggable terminal strips chapter 5.2 "Connection elements and connectors", Page 18

2.2 Brief description

The electronic thermostat can be used as a heating or cooling thermostat or optionally as a PID two-state controller. It acquires the process variables via an RTD temperature probe. When used as a PID two-state controller, the controller structures P, I, PD, PI, and PID are possible. The device is equipped with a relay output (16 A).

The difference between the two types of devices is the diameter of the front panel: Type 701090 Ø 60.5 mm, Type 701091 Ø 80.5 mm. The round housing design allows the device to be used wherever round dial instruments were previously in use.

The device is characterized by simple, clearly structured operation supported by texts in English, German, French, and Spanish. Process values, texts, and parameters are shown in two 18-segment LCD displays. Additional display elements inform about the switch position of the output, the timer status, and temperature unit.

Pluggable terminal strips with PUSH IN technology enable fast electrical installation.



Operation, parameterization, and configuration are carried out via a membrane keyboard with four keys. The setup program on a PC allows the device to be configured without any problems. No separate voltage supply is required when configuring via the USB interface (USB-powered).

2.3 Identifying the device version

2.3.1 Nameplate

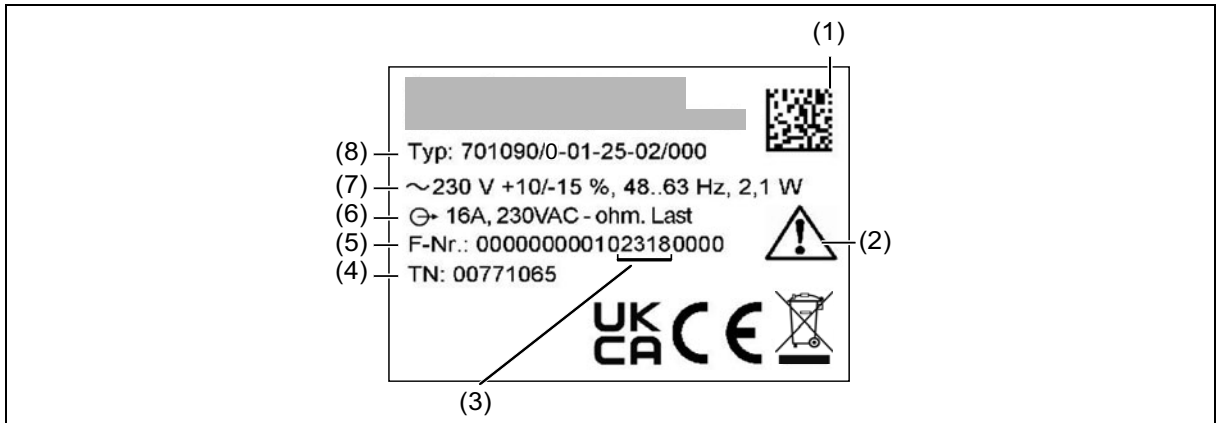
The specifications on the nameplate are for device identification purposes. It is stuck on the side of the device and contains the following information:



1	Data matrix code (for manufacturing purposes only)	2	Note "Read the operating manual"
3	Production date, Pos. 12-15 of F no.: Year number, calendar week	4	Part no.
5	Fabrication number (F no.)	6	Switching capacity (relay output)
7	Voltage supply - Direct voltage  - Alternating voltage 	8	Type, corresponds to the order details

2 Description

2.3.2 Order details

(1) Basic type	
701090	Type 701090 with 1 relay, format (Ø 60 x 80) mm
701091	Type 701091 with 1 relay, format (Ø 80 x 80) mm
(2) Version	
0	Standard version
1	Customized hardware
2	Customized software
3	Customized hardware and software
(3) Input (measurement input group)	
01	1 RTD temperature probe Pt100, Pt1000 in two-wire circuit, 1 digital input
(4) Output	
25	1 relay (normally open contact AC 250 V, 16 A) resistive load
(5) Voltage supply	
02	AC 230 V, +10/-15 %, 48 to 63 Hz
05	AC 115 V, +10/-15 %, 48 to 63 Hz ^a
30	DC 12 to 24 V +15/-15 %
(6) Extra codes	
000	None
033	PID two-state controller

^a Minimum order quantity 50 pieces

	(1)	(2)	(3)	(4)	(5)	(6)					
Order code	<input type="text"/>	/	<input type="text"/>	-	<input type="text"/>	-	<input type="text"/>	-	<input type="text"/>	/	<input type="text"/>
Order example	701090	/	0	-	01	-	25	-	02	/	033

2.3.3 Scope of delivery

1 device in the ordered version
1 quick start guide
2 panel fasteners
Pluggable terminal strips

2.3.4 Accessories

Description	Part no.
Setup program	00777355
USB cable, A connector to Micro-B connector, length 3 m	00616250
Activation for PID two-state controller (setup program required)	00777354

3 Acceptance of goods, storage, and transport

3.1 Checking the delivery

- Ensure that the packaging and its contents are undamaged.
- Check the delivery for completeness against the packing slip and order details.
- Inform the supplier immediately if there is any damage.
- Store damaged parts until clarification is received from the supplier.

3.2 Important information about storage and transport

- Store the device in a dry, clean environment. Observe the admissible ambient conditions (see "Technical data")
- Protect the device from shock during transport
- The original packaging provides optimum protection for storage and transport

3.3 Returning goods

If repairs are needed, return the complete device in clean condition.

Use the original packaging to return goods.

Accompanying letter for repair

Please include the completed accompanying letter for repair when returning goods.

Do not forget to state the following:

- Description of the application and
- Description of the error that has occurred

The accompanying letter for repair (supplementary sheet for product returns) can be downloaded online from the manufacturer's website:

<http://productreturn.jumo.info>

Protection against electrostatic discharge (ESD)

(ESD = electrostatic discharge)

To prevent damage due to ESD, electronic modules or components must be handled, packaged, and stored in an ESD-protected environment. Measures that protect against electrostatic discharge and electric fields are described in DIN EN 61340-5-1 and DIN EN 61340-5-2 "Protection of electronic devices from electrostatic phenomena".

When sending back electronic modules or components, please note the following:

- Pack sensitive components only in an environment providing protection against ESD. Workspaces such as this divert electrostatic charges to ground in a controlled manner and prevent static charges due to friction.
- Use only packaging intended specifically for ESD-sensitive modules/components. These must consist of conductive plastics.

No liability can be assumed for damage caused by ESD.



CAUTION!

Electrostatic charges occur in non-ESD-protected environments.

Electrostatic discharges can damage modules or components.

- ▶ For transport purposes, use only the ESD packaging provided.
-

3 Acceptance of goods, storage, and transport

3.4 Disposal

Disposing of the device



DISPOSAL!

Devices and/or replaced parts should not be placed in the refuse bin at the end of their service life as they consist of materials that can be recycled by specialist recycling plants.

Dispose of the device and the packaging material in a proper and environmentally friendly manner.

For this purpose, observe the country-specific laws and regulations for waste treatment and disposal.

Disposing of the packaging material

The entire packaging material (cardboard packaging, inserts, plastic film, and plastic bags) is fully recyclable.

4.1 Installation instructions



WARNING!

The device is not designed for use in potentially explosive areas.

Explosion hazard.

- ▶ Only deploy the device outside of potentially explosive areas.
-

Mounting site

The device is designed for installation in a panel cut-out within a closed switch cabinet. The front of the device and housing have different protection types (see technical data).

Climatic conditions

The ambient temperature and the relative humidity at the mounting site must correspond to the technical data. Aggressive gases and vapors have a negative effect on the operating life of the device. The mounting site must be free from dust, powder, and other suspended solids.

Installation position

The device can be installed in any position.

The maximum admissible ambient temperature only applies for the installation with the display in a vertical position.

Technical data

- ⇒ chapter 8 "Technical data", Page 25

4 Mounting

4.2 Dimensions

4.2.1 Type 701090

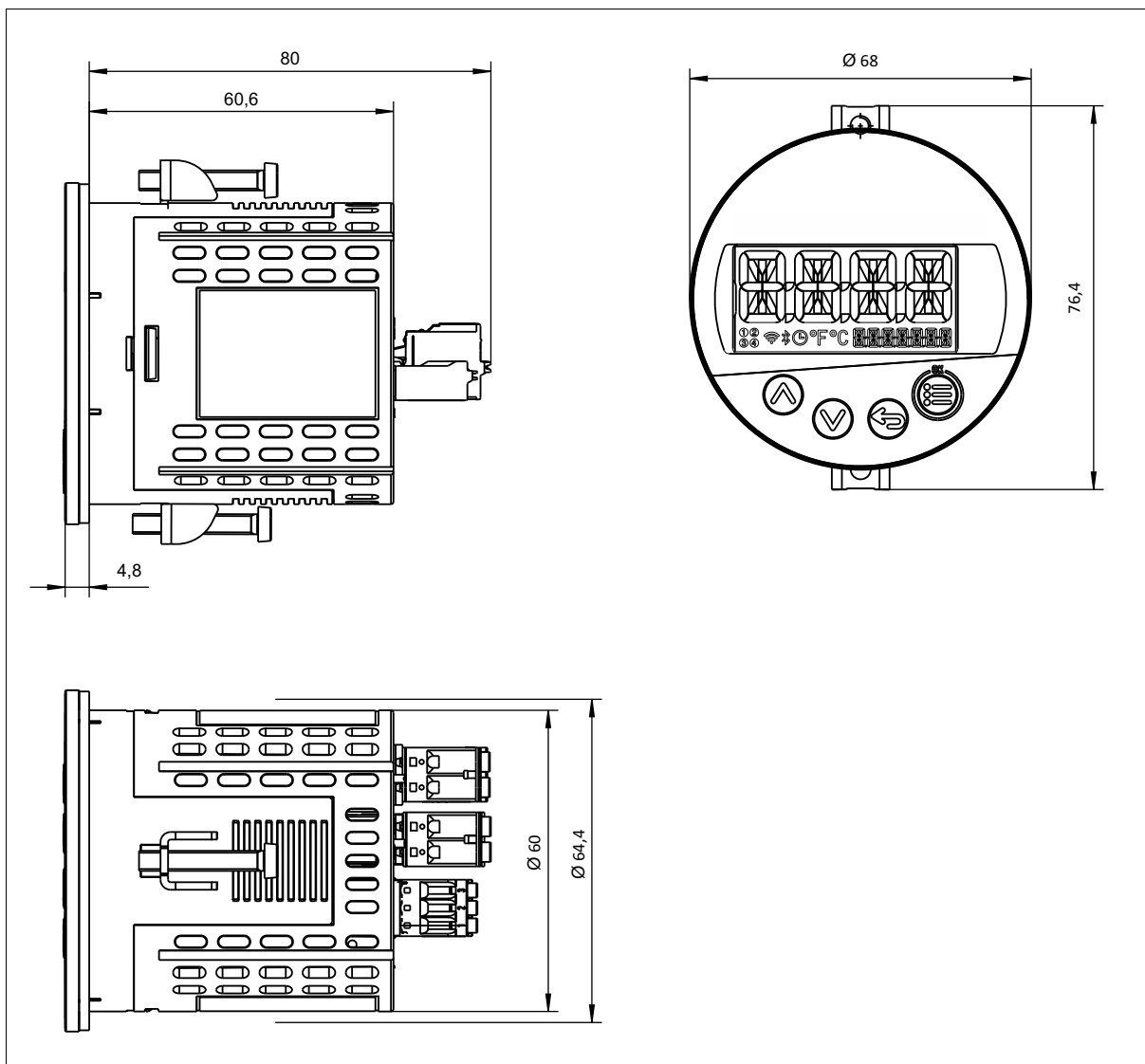

4.2.2 Type 701091

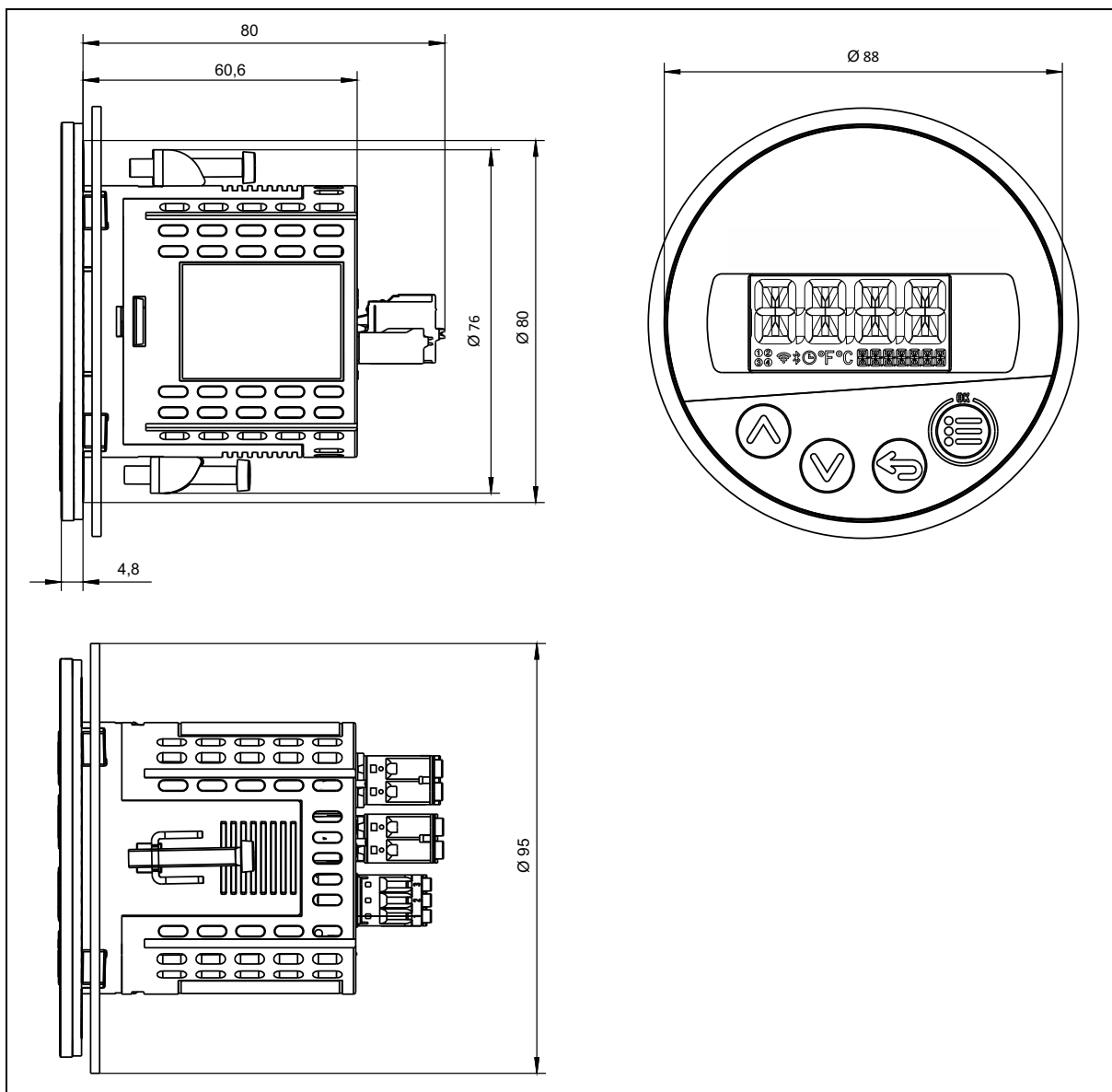

4.2.3 Installation dimensions

Type	Panel cut-out Ø	Mounting depth without seal	Minimum spacing of panel cut-outs (for close mounting)	
			Horizontal	Vertical
701090	60.5 +0.5 mm	80 mm	15 mm	30 mm
701091	80.5 +0.5 mm			

4 Mounting

4.3 Panel mounting



CAUTION!

The front of the device and housing have different protection types!

The protection type IP65 (front-side) is only guaranteed if the seal is flush and even.

- ▶ Use the mounting frame or both mounting elements as shown in the figure and ensure an even attachment!

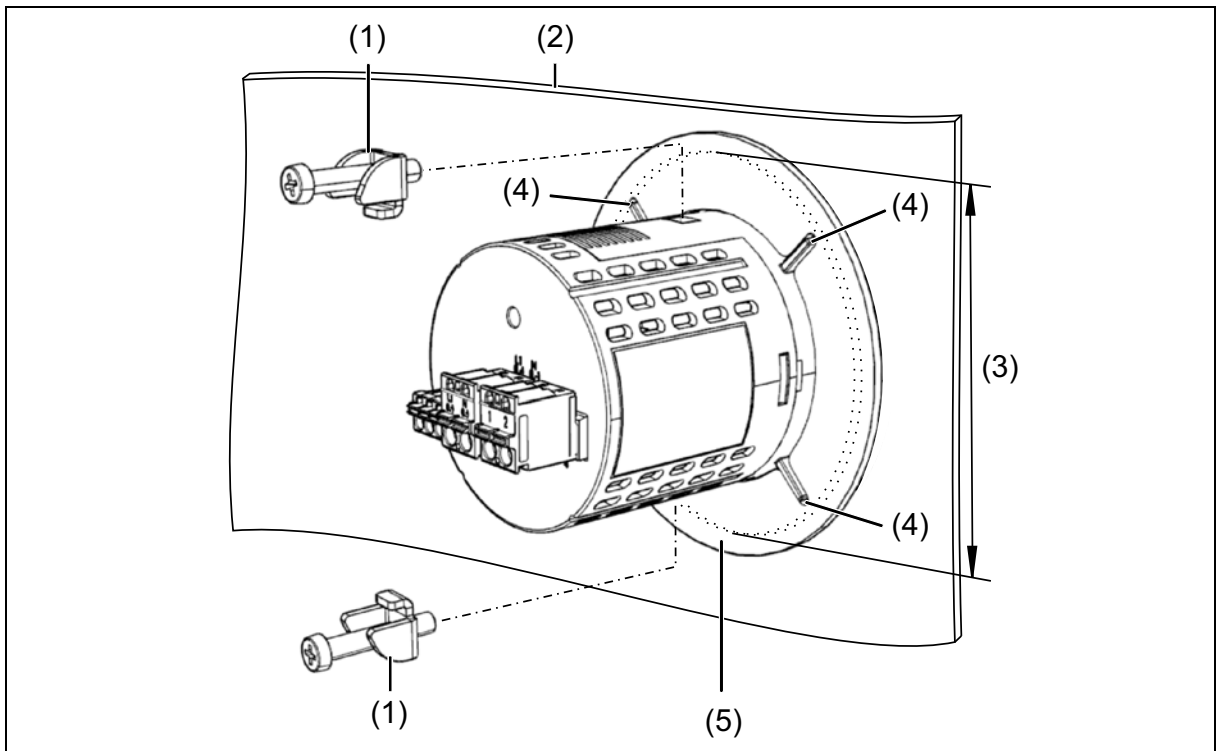

1	Panel fasteners	2	Panel
3	Panel cut-out	4	Supporting lugs
5	Adapter plate		

1. Create panel cut-out (see installation dimensions).
2. Insert the device from the front into the panel cut-out and ensure that the seal is correctly positioned.
3. Only for device with diameter 80 mm: First, on the back of the panel, slide the adapter plate onto the device from behind.
4. Insert the upper panel fastener into the device body and turn the screw in by hand until it reaches the adapter plate.
5. Insert the lower panel fastener into the device body and turn the screw in by hand until it reaches the adapter plate.
6. Tighten both screws with a Phillips screwdriver.

The mechanical installation is completed.

5.1 Installation notes

Requirements for personnel

- Work on the device must only be carried out to the extent described and, like the electrical connection, only by qualified personnel.
- Before plugging and unplugging connecting cables, it must be ensured that the acting person is electrostatically discharged (by touching grounded metallic parts, for example).

Cables, shielding, and grounding

- When selecting the electrical wiring material as well as when installing and connecting the device electrically, comply with the requirements of DIN VDE 0100 "Low-voltage electrical installations" and the applicable country-specific regulations (for example, based on IEC 60364).
- It may be necessary to adhere to special notes relating to the heat resistance of cables (see connection diagram).
- Route input, output, and supply lines separately and not parallel to one another.
- Only use shielded and twisted probe and interface cables. Do not route the lines close to current-carrying components or cables.
- For temperature probes, ground the shielding on one side in the control cabinet.
- Do not perform loopthroughs on the grounding cables, but instead route the cables individually to a shared grounding point in the control cabinet; in doing so, ensure that the cables are as short as possible.
Ensure that the potential equalization is correct.

Electrical safety

- The device is intended to be installed in control cabinets or plants. Ensure that the customer's fuse protection does not exceed 20 A. Disconnect the device from the mains voltage on all poles prior to starting service or repair work.
- The relay's load circuit can be operated with a hazardous electrical voltage (e.g. 230 V). De-energize the load circuit during mounting/dismounting and electrical connection.
- To prevent the relay contacts being destroyed in the case of an external short-circuit in the load circuit, the latter must be fuse-protected as per the maximum admissible relay current (see technical data).
- The device is not suitable for installation in potentially explosive areas.
- In addition to a faulty installation, incorrectly set values on the device can also impair the correct function of the downstream process. Therefore, ensure that safety devices independent of the device, e.g., overpressure valves or temperature limiters/monitors, are present and that it is only possible for qualified personnel to define settings. Please observe the corresponding safety regulations in this context.

References to other information

- The electromagnetic compatibility conforms to the standards and regulations cited in the technical data.
- In general, please observe the specifications regarding electrical isolation.

5 Electrical connection



DANGER!

Risk to life due to electric shock

Risk of injury when touching live parts!

- ▶ Only qualified electricians are allowed to connect and install an electrical device that is not already ready to use.
- ▶ Before working on the system or device, switch off the voltage and secure it so that it cannot switch on again.
- ▶ Do not touch electronic components when they are live.
- ▶ Always observe the relevant accident prevention regulations and safety requirements for electrical devices.

5.2 Connection elements and connectors



NOTE!

Please refer to the sticker on the device for the correct terminal assignment.

As a general rule, use ferrules when connecting stranded cables.

Both device types are equipped with pluggable terminal strips with push-in spring connection. The connections are consolidated by type into four groups:

- 1 - Micro USB (setup interface)
- 2 - Analog input (sensor) and digital input
- 3 - Voltage supply (see nameplate)
- 4 - Digital output (relay)

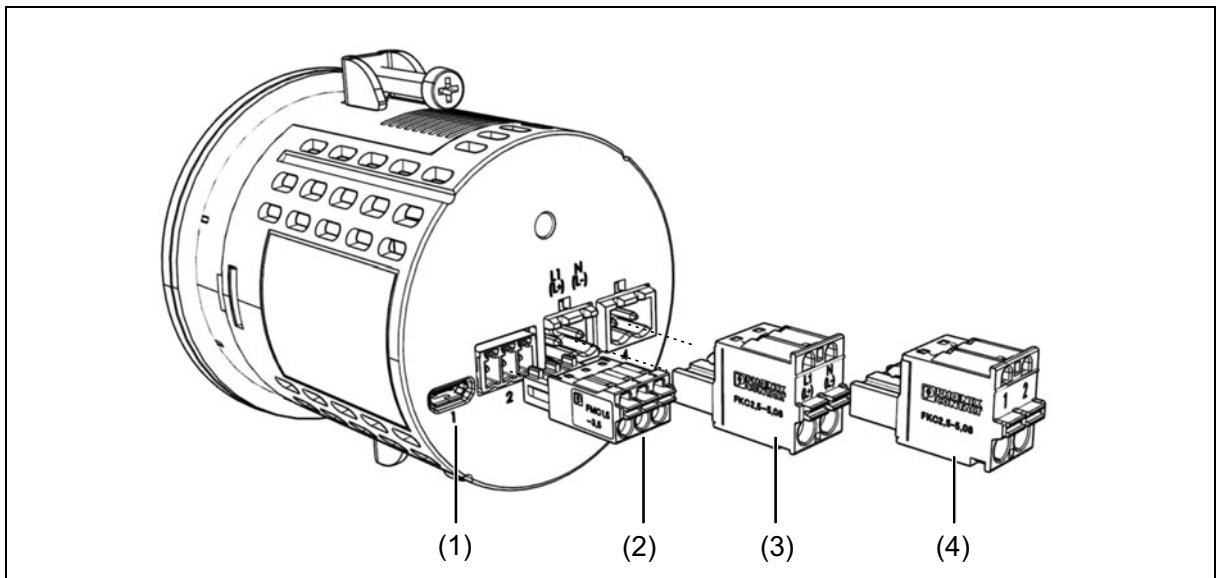

5.3 Connection diagram



CAUTION!

Risk of device damage

If the device is not supplied with the voltage specified on the nameplate, this could cause damage to the device.

- ▶ Only supply voltage from a voltage source that matches the specifications on the nameplate.



CAUTION!

In unfavorable conditions, the temperature may exceed 60 °C at the terminals.

As a result, the insulation of the lines connected at the terminals may be damaged.

- ▶ The affected cables must be heat-resistant up to at least 80 °C.
- ▶ Relay (16 A): the affected cables must be heat-resistant up to at least 95 °C.



NOTE!

Only copper conductors are allowed to be connected to the terminals.

5.3.1 Type 701090 (Ø 60) and Type 701091 (Ø 80)

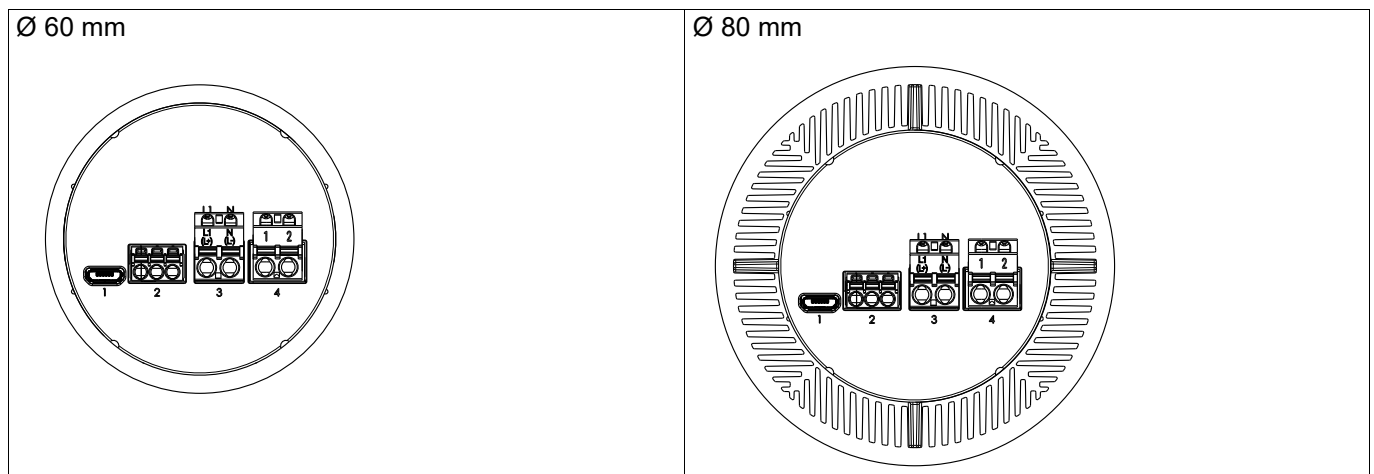

Terminal strip 2 Analog input, digital input

RTD temperature probe in two-wire circuit and digital input

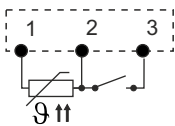

Terminal strip 3 L1(L+), N(L-)

Voltage supply (see nameplate)
AC 230 V, 48 to 63 Hz
or
AC 115 V, 48 to 63 Hz
or
DC 12 to 24 V

Terminal strip 4 Digital output

1 relay normally open contact

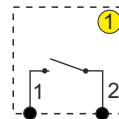

5 Electrical connection

5.4 Galvanic isolation

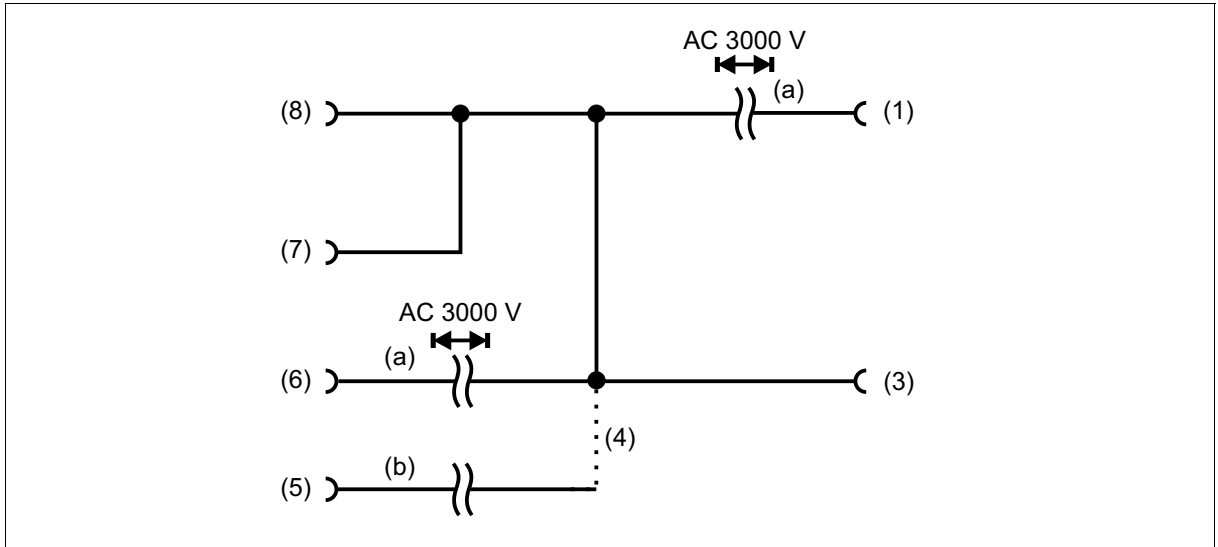

a	The voltage specifications correspond to the test voltages (alternating voltage, rms values) according to DIN EN 61010-1 (VDE 0411-1):2020-03	b	Functional galvanic isolation for connecting SELV or PELV electrical circuits
1	Relay output		
3	USB interface	4	or
5	Voltage supply DC 12 V to 24 V	6	Voltage supply 230 V, 48 to 63 Hz 115 V, 48 to 63 Hz
7	Digital input	8	Analog input



CAUTION!

The analog input and the USB interface are not galvanically isolated.

- ▶ Do not connect the USB with a grounded sensor if the ground of the PC is also grounded (e.g. a desktop PC).

The primary operator interface on the device is the front side membrane keyboard with the display. It enables users to quickly operate and configure the device at the device installation location. Non-relevant parameters, sub-parameters, selector and selection settings are hidden by the software for operation of the device if

- the device does not have the hardware,
- the option is not enabled,
- the function is switched off,
- the function does not match the parameter.

The individual parameters for device setting are organized in different levels that can be inhibited. A level inhibit helps to prevent accidental or unauthorized operation.

As soon as a value can be edited, it starts flashing on the display. If you click the "OK/Menu" key, the device accepts the set value. You can abort the process and retain the old value by pressing the "BACK" key.

The 30-day test version of the setup program allows you to easily configure the device using a PC. The following functions can only be configured with the setup program.

- User level
- Customer-specific linearization

The setup program is available to download. The license number for the full version of the setup program is available for a fee and can be requested from your sales partner.

6.1 Display and control elements

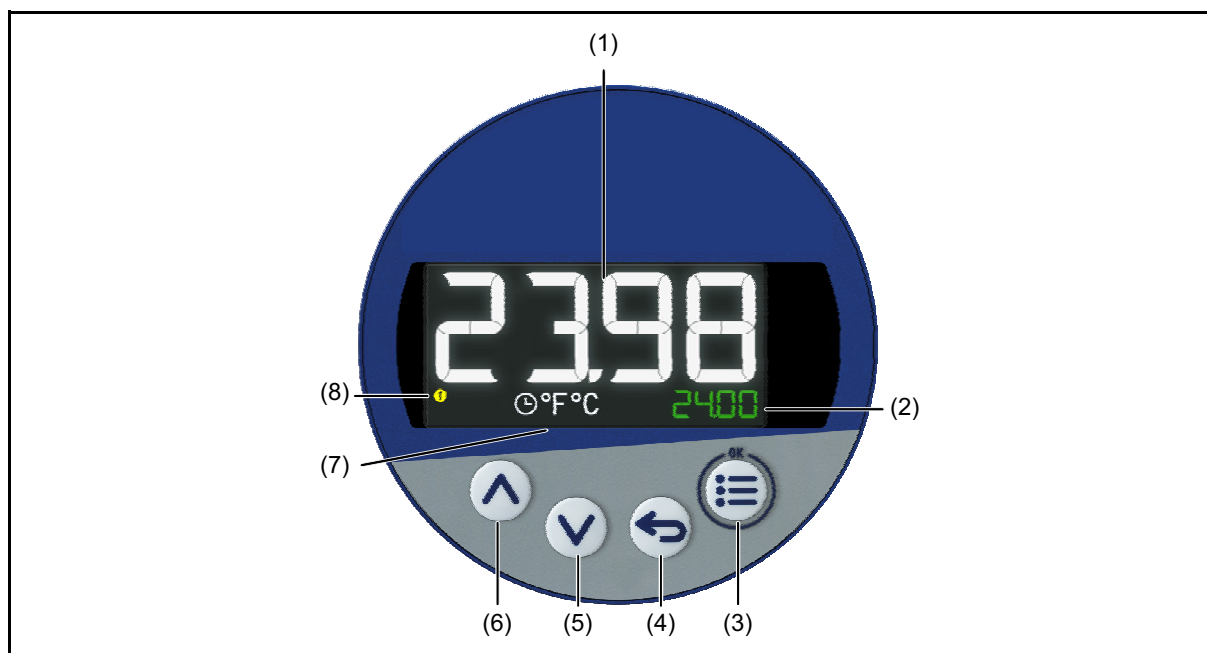









1	Display 1 - 18-segment LCD display (e.g. actual value), 4-digit, white; also for displaying menu items, parameters and text	2	Display 2 - 18-segment LCD display (e.g. setpoint value), 7-digit green; also for displaying menu items, parameters, values, and text
3	Menu/OK (call up main menu, switch to sub-menu/level, switch to editing mode, exit editing mode with change)	4	Back (in menu: back to previous menu level, exit editing mode without change; in basic status: configurable function)
5	Down (in the menu: reduce value, select next menu item or parameter; reduce setpoint value or, in manual mode, output level)	6	Up (in the menu: increase value, select previous menu item or parameter; increase setpoint value or, in manual mode, output level)

6 Operation

7	Timer (illuminated = on, flashing = started), Temperature Unit	8	Switch position of the digital outputs (yellow = active)
---	--	---	--

6.1.1 Operating overview

Button functions

Button or button combination (permanent)	In basic status	Function	
		When navigating	When editing
Up 	Increase setpoint value In manual mode: increase output level	Select previous menu item or parameter	Increase value or go up in picklist
Down 	Decrease setpoint value In manual mode: reduce output level	Select next menu item or parameter	Decrease value or go down in picklist
Back short (< 3 s) 	Function configurable (default setting: no function)	Move to menu level above	Leave editing mode without changes
Back long (> 3 s) 	Function configurable (default setting: without function)	---	---
Menu/OK short (< 3 s) 	Call up main menu	Call up sub-menu or switch to editing mode	Leave editing mode with changes
Up + Down long (> 3 s)  + 	Start/stop autotuning	---	---
Down + Menu/OK very long (> 5 s)  + 	Call up menu for level inhibit	---	---

6.2 Language selection

After switching on the device for the first time, the user can either confirm the flashing displayed language with "OK" or select another language using the "Up"/"Down" buttons and then confirm this with "OK".

After applying a language, the device automatically sets this parameter to "OFF", meaning that language selection is not necessary the next time the device is switched on.

If, at a later point, another user is also to have the option of selecting a language, the configuration parameter "LANGUAGE SELECT. POWER ON" can be set to "ON" in the menu (Configuration > System data).

The language of the device texts can be changed at any time in the configuration settings. This is irrespective of the language selection after switching on the device.

7 Maintenance, cleaning, troubleshooting

7.1 Maintenance

The device is maintenance-free. In the event of damage, e.g. due to transport, maintenance, or faults during operating, it is not permissible to carry out repairs on the device. If the device is opened up, the warranty claim becomes void.

In the event of any damage, send the device to your responsible service partner. See back cover of this operating manual.

7.2 Cleaning

When delivered, the membrane keyboard and the display have a protective film. If the device front becomes dirty during operation, clean the device front with a soft cloth and mild soapy water.



CAUTION!

Risk of damaging the device front!

Cleaning agents such as gasoline, solvents, and abrasive cleaning agent as well as cleaning the device with a high-pressure cleaner can cause irreparable damage to the device front.

- ▶ Always clean the device front with a soft cloth and mild soapy water.

7.3 Troubleshooting

7.3.1 Types of errors

Potential types of errors:

- System errors that are detected by hardware or software (e.g. probe break, overrange)
- Fault messages set by the customer in the configuration
(Fault message if the binary input switches from 0 to 1 or if a set limit value is exceeded)
- Runtime error (e.g. division by 0, internal RAM storage faulty, etc.)

7.3.2 Error messages

Display	Possible cause ^a	Measures
<<<<	Measuring range underflow	Check probe and line (break, short circuit, reverse polarity)
>>>>	Measuring range overflow	
++++	Temperature for compensation outside	Check connection terminals
----	Probe or line break Probe or line short circuit Not a valid input value Display capacity exceeded invalid value	Check configuration (signal type, linearization, resistance measuring range, scaling)

^a Depending on the signal type (measuring probe)

In the event of a fault, the controller switches to manual mode.

8.1 Analog input

RTD temperature probe

Designation	Standard	ITS	Connection type	Measuring range	Accuracy ^a	Measuring current
Pt100	DIN EN 60751:2008 IEC 60751:2008	ITS-90	Two-wire	-200 to +600 °C	≤ 0.25 %	500 μA
Pt1000	DIN EN 60751:2009 IEC 60751:2008	ITS-90	Two-wire	-200 to +600 °C	≤ 0.25 %	100 μA
Customer-specific				150 to 3000 Ω	≤ 0.25 %	< 500 μA

^a Accuracy refers to the measuring range.

Ambient temperature influence	≤ 300 ppm/K
Sensor line resistance	Max. 30 Ω per line
Input filter	Digital filter, 2nd order; filter constant can be set from 0 to 100.0 s

Measuring circuit monitoring

The device behavior in the event of a malfunction is configurable.

Measuring probe	Measuring range underflow	Measuring range overflow	Short-circuit (probe/line)	Break (probe/line)	Reverse polarity
RTD temperature probe	++	++	++	++	---
++ = is detected		--- = is not detected		(+) = is detected in certain conditions	

8.2 Digital input

Input for potential-free contact Function	Contact closed: input is active ($R_{ON} < 1 \text{ k}\Omega$) Contact open: input is inactive ($R_{OFF} > 100 \text{ k}\Omega$)
--	---

8.3 Digital output

1 relay (normally open contact) Switching capacity Contact life	Max. 16 A at AC 250 V, resistive load 100,000 switching operations at rated load	Order code 25
---	---	------------------

8 Technical data

8.4 Display

18-segment LCD displays		
Digit height	Upper display: 13 mm	Lower display: 4 mm
Color	white	Green
Places, including decimal places	4	7
Decimal places	0, 1, or automatic (configurable)	

8.5 Electrical data

Voltage supply according to the ordered version	02	AC 230 V -15/+10 %, 48 to 63 Hz		
	05	AC 115 V -15/+10 %, 48 to 63 Hz		
	30	DC 12 to 24 V, -15/+15 % SELV		
Electrical safety	acc. to DIN EN 61010, part 1 Overvoltage category II to 300 V mains voltage, Pollution degree 2			
Power consumption Type 701090 Type 701091	Type AC 230 V: Max. 2.1 W Max. 2.1 W	Type AC 115 V: Max. 3.3 W Max. 3.3 W	Type DC 12 to 24 V: Max. 1.2 W Max. 1.2 W	
Accuracy of timer	1 %			
Sampling rate	250 ms			
Electrical connection	On the back via plug connectors with spring-cage terminals (PUSH IN technology)			
Conductor cross section, mechanical Wire or stranded wire (without ferrule) Stranded wire with ferrule Stripping length	Min. 0.2 mm ² , max. 1.5 mm ² (terminal strips 3 and 4: max. 2.5 mm ²) Without plastic collar: min. 0.25 mm ² , max. 1.5 mm ² (terminal strips 3 and 4: max. 2.5 mm ²) With plastic collar: min. 0.25 mm ² , max. 0.75 mm ² (terminal strips 3 and 4: max. 2.5 mm ²) 8 mm			
Conductor cross section, electric 5 A load current 10 A load current 16 A load current	Min. 0.75 mm ² Min. 1.0 mm ² Min. 1.5 mm ²			

8.6 Environmental influences

Ambient temperature range	
Storage	-30 to +70 °C
Operation	-10 to +55 °C
Site altitude	Max. 2000 m above sea level
Climatic environmental influences	According to DIN EN 60721-3 with extended temperature range
Resistance to climatic conditions	≤ 90 % rel. humidity without condensation
Storage	According to class 1K2
Operation	According to class 3K3
Mechanical environmental influences	According to DIN EN 60721-3
Storage	According to class 1M2
Transport	According to class 2M2
Operation	According to class 3M3
Electromagnetic compatibility (EMC)	Product family standard DIN EN 61326-1
Interference emission	Class B ^a
Interference immunity	Industrial requirement

^a The product is suitable for industrial use as well as for households and small businesses

8.7 Housing

Case type	Plastic case for panel mounting according to IEC 61554 (indoor use), cobalt blue RAL 5013
Case front	Membrane keyboard, upper slope cobalt blue RAL 5013, lower slope silver grey RAL 7001
Panel thickness	1 to 10 mm
Case mounting	In panel using the supplied mounting frame or both mounting elements
Operating position	Any ^a
Protection type	According to DIN EN 60529, IP65 on the front, IP20 on the back
Weight	
Type 701090	Max. 160 g
Type 701091	Max. 240 g

^a The maximum admissible ambient temperature only applies for the installation with the display in a vertical position.

8.8 Approvals and approval marks

Approval mark	Test facility	Certificates/Certification numbers	Inspection basis	Valid for
c UL us	Underwriters Laboratories	E201387	UL 61010-1 (3rd Ed.), CAN/CSA-22.2 No. 61010-1 (3rd Ed.)	All types

The device is approved if the relevant approval mark is pictured on the device.

8 Technical data

JUMO

OneTemp^o pty ltd
measure | control | record
1300 768 887
www.onetemp.com.au

