

JUMO ecoLine Ci

Inductive conductivity and temperature sensor for general water engineering

Brief description

The sensor detects the electrolytic conductivity of a process liquid. It uses the inductive principle of measurement. Because it uses the inductive method of measurement rather than the conductive 2-pin or 4-pin measurement method, the sensor is virtually maintenance-free. The measuring accuracy is practically unaffected by accumulations and grease or oil film on the surface of the sensor.

A (Pt1000) temperature sensor acquires the process temperature at the same time. The temperature sensor can either be exposed in a stainless steel pocket (ultra-fast response) or be located right inside the plastic body (with PVDF, only the internal option is possible). Internal installation is advisable if the sample media could chemically attack the stainless steel pocket.

The standard sensor body material is polypropylene (PP). PVDF is also available as an alternative.

A vast number of process connections are available to ensure system flexibility, even to provide spare equipment for older devices.

The JUMO ecoLine Ci sensor is designed for connection to the JUMO AQUIS 500 Ci transmitter, as per data sheet 202566.

Typical areas of application:

The sensor is primarily designed for use in water engineering systems. Typical areas of application include general water engineering (drinking water and wastewater), air-conditioning and cooling plants, dilution monitoring in cooling towers, flushing tanks, carwashes, sea water desalination (inlet), monitoring swimming pool water, etc. There is an immersion variant that can be used in open channels and containers.

Product advantages:

- Practically maintenance-free conductivity measurement
- Materials are FDA/food-use approved
- A variety of process connection variants
- A fast-response temperature sensor
- A compact, proven sensor



Type 202943/10-...



Type 202943/10-... with T-piece made from PVC

Technical data

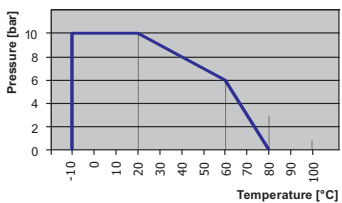
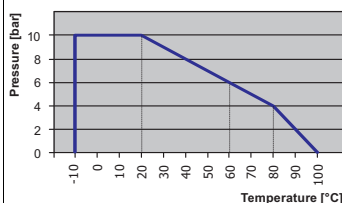
Type	202943/10-...	202943/20-...	202943/30-...
Conductivity measurement principle	Inductive		
Conductivity meas. range^a	0 ... 1000 µS/cm to 0 ... 2000 mS/cm (depending on connected transmitter)		
Conductivity accuracy for measuring range:			
0 - 1 mS/cm	≤ 1 %		
0 - 10 mS/cm	≤ 0.5 %		
0 - 50 mS/cm	≤ 0.5 %		
0 - 100 mS/cm	≤ 0.5 %		
0 - 1000 mS/cm	≤ 1 %		
0 - 2000 mS/cm	≤ 1 %		
Cell constant	k = 6.25 1/cm		k = 4.65 1/cm
Temperature sensor	Pt1000, Class A		
t₉₀ temperature^b	≤ 6 s	≤ 2 min	≤ 10 min
Permissible ambient temperature	-10 to +60 °C		
Permissible storage temperature	-20 to +75 °C		
Enclosure protection^c	IP68		
Permissible medium temperature^d In operation Momentary with process connections 168 and 706 (immersion fitting)	-10 to +80 °C ≤ +100 °C (≤ 15 min) -10 to +60 °C (pressureless)		-10 to +100 °C ≤ +110 °C (≤ 15 min) -10 to +60 °C (pressureless)
Permissible process pressure^c at +20 °C at +60 °C at +80 °C at -10 to +100 °C	10 bar 6 bar 0 bar min. -0.1 bar 		10 bar 6 bar 4 bar min. -0.1 bar 
Sensor material in contact with medium not in contact with medium	dependent on design: stainless steel 1.4301 (304), stainless steel 1.4571 (316ti), PP, EPDM dependent on design: stainless steel 1.4301 (304), PA6, PUR, FPM, PBT/PA, CR/NBR, CuZn	dependent on design: stainless steel 1.4301 (304), PP dependent on design: stainless steel 1.4301 (304), PA6, PUR, FPM, PBT/PA, CR/NBR, CuZn	PVDF dependent on design: stainless steel 1.4408, PA6, PUR, PBT/PA, CR/NBR, CuZn
Process connection	see Order details / Dimensions		
Electrical connection Connection circuit Socket Socket material Cable material Cable lengths Permissible temperature	JUMO ecoLine Ci type inductive conductivity sensors are suitable for connection to JUMO AQUIS 500 Ci type inductive conductivity transmitters/controllers! non-detachable cable M12 socket, 8-pin CuZn, PA6.6 GF30, PUR outer sleeve: PUR see Order details -20 to +75 °C		
Approvals/marks of conformity	Materials in contact with the medium are approved for food use, are physiologically safe and are listed by the FDA.		

^a Usual application range from approx. 100 µS/cm.

^b EN 60751

^c EN 60529

^d **Note:** Temperature, pressure and sample medium affect the life of the cell!

Principle of measurement

The inductive method of measurement allows largely maintenance-free acquisition of specific conductivity, even in the toughest media conditions. Compared with the conductive method of measurement, problems such as electrode decomposition and polarization are practically non-existent.

Conductivity is measured by an inductive probe. Sinusoidal AC voltage supplies the transmitter coil. Current is induced in the receiver coil, subject to the conductivity of the liquid to be measured. The current is proportional to the conductivity of the medium.

Device description

Sensor

The sensor consists of a hermetically sealed polypropylene (PP) or polyvinylidene fluoride (PVDF) body, with two measuring coils arranged inside it. A flow-through opening in the sensor allows the sample medium to pass through. Electrical isolation between the sample medium and the actual value output is inevitable, because of the principle of measurement. The sensor is extremely temperature and pressure stable.

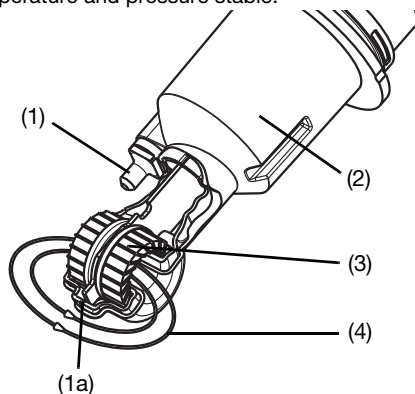

- (1) exposed temperature sensor
- (1a) option: internal
- (2) PP cell body
- (3) measuring coils
- (4) liquid loop

Exposed temperature sensor:

The sensor in its stainless steel pocket reacts very quickly to changes in temperature.

Internal temperature sensor:

The sensor is integrated in the cell body. No metal comes into contact with the sample medium in this version (important for aggressive media). However, temperature acquisition is slower.

Measurement section setup

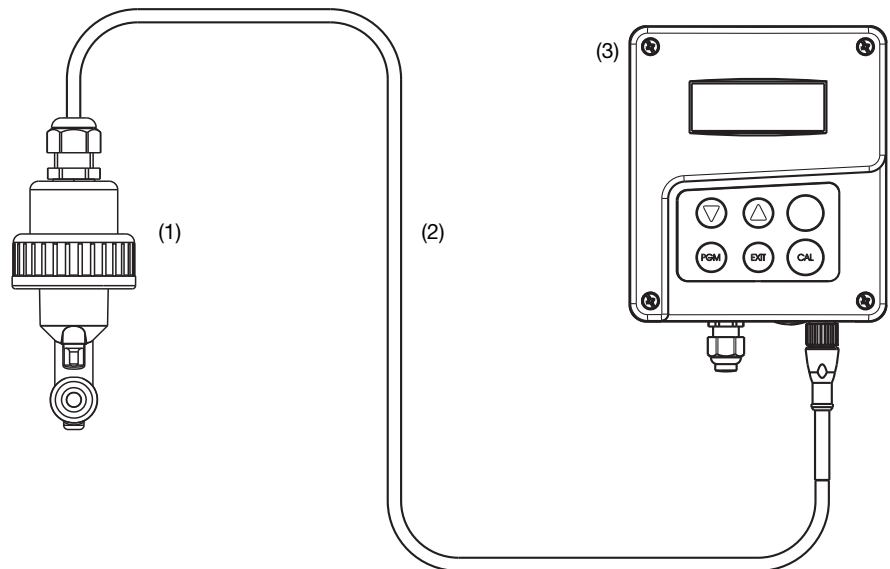

- (1) JUMO ecoLine Ci, inductive conductivity and temperature sensor
- (2) Cable (component part of JUMO ecoLine Ci), standard length 10 m
- (3) JUMO AQUIS 500 Ci, transmitter/controller for conductivity, concentration and temperature

Sensor details

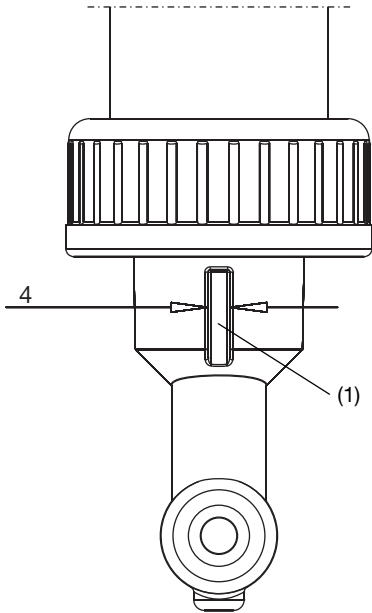

Guide slot

A lug on the T-piece (see Accessories) fits into the 4 mm wide guide slot (1), thus ensuring that the sensor is correctly aligned to the direction of flow.

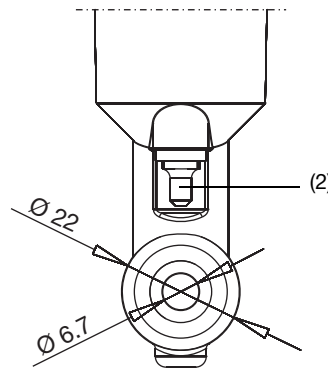

Exposed temperature sensor (2)

This is the standard version.

Material in contact with sample medium:
stainless steel 1.4571 AISI 316ti and FPM.

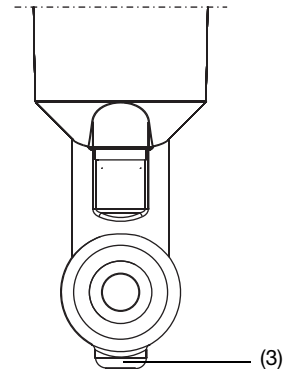

Internal temperature sensor (3)

Extra code 268.

Material in contact with sample medium:
PP, suitable for food use.

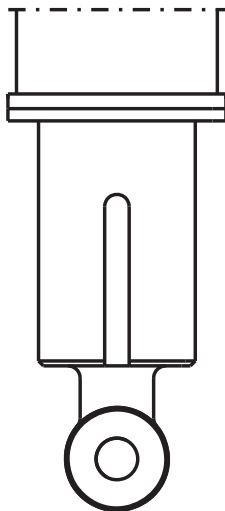

PVDF sensor body

Cell constant 4.65 1/cm,
only available for process connections 168
and 169

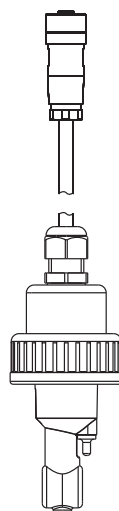

Process connection 168

for T-piece installations,
PVC union nut (included among the items
supplied)

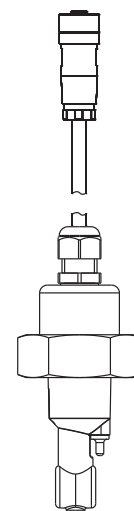

Process connection 169

for T-piece installations,
stainless steel union nut (included among
the items supplied)

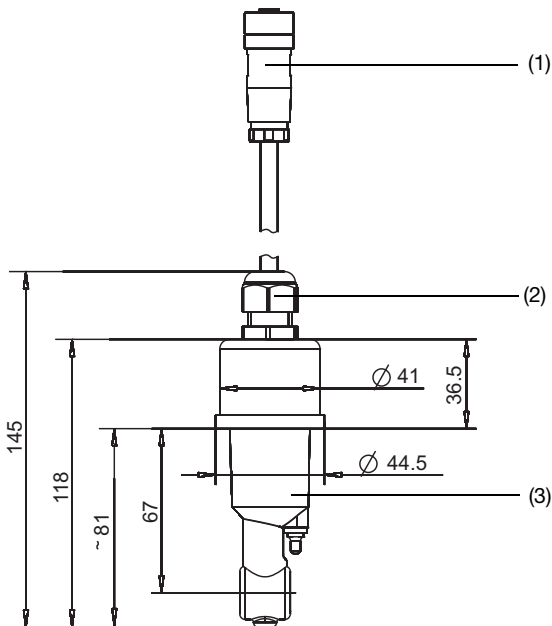

**Type 202943/10-168... or -169...
DN32 or DN40**

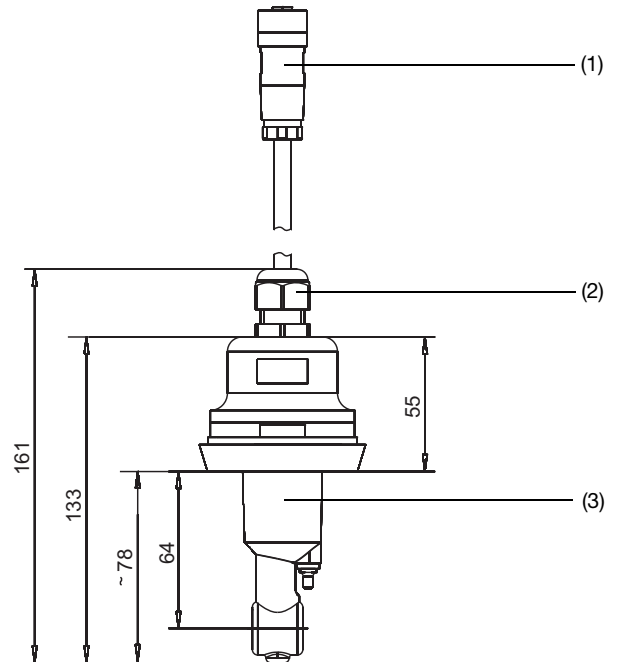

**Type 202943/10-607-...
MK DN50**

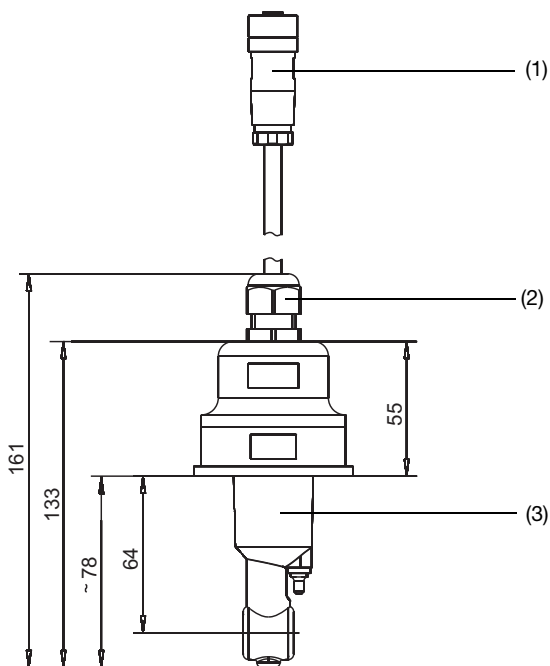

**Type 202943/10-690-...
2" SMS**

- (1) M12 socket, PBT / PA
- (2) M16 screw-type cable gland
IP68 protection (to 0.2 m), PBT / PA
- (3) PP
- (4) 1.4301 stainless steel, AISI 304

Dimensions

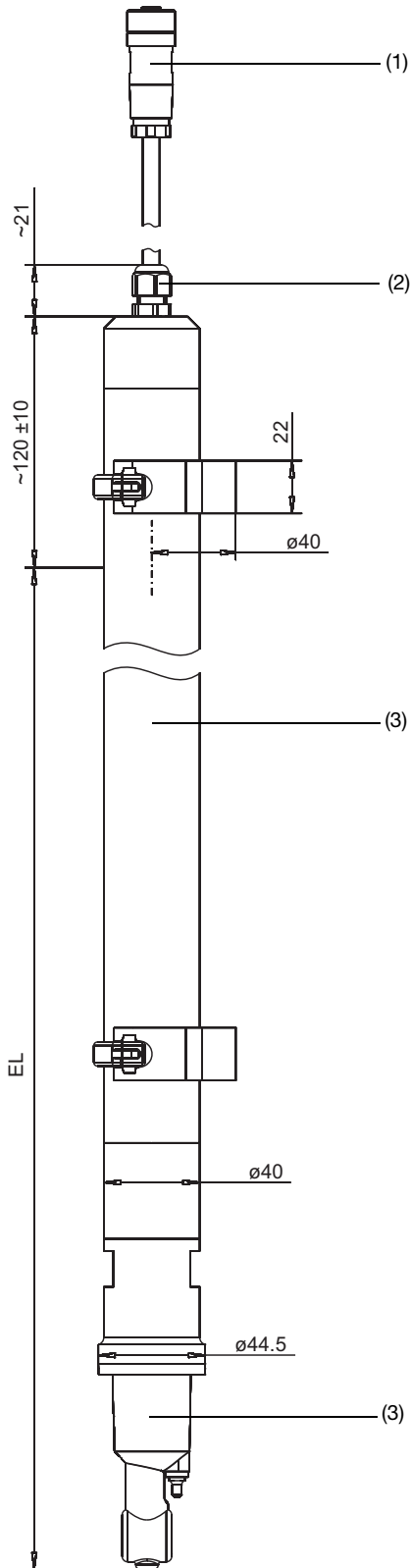

Type 202943/10-706-...
Immersion version

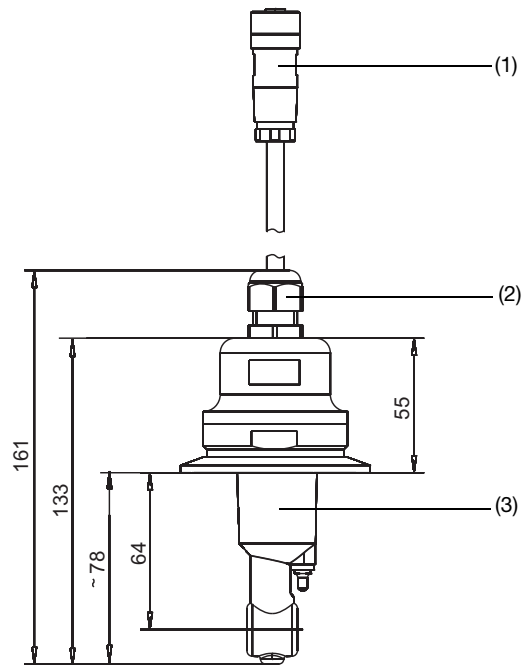

Type 202943/10-617-... or -616-...
2" clamp or 2 1/2" clamp

- (1) M12 socket, PBT / PA
- (2) M16 screw-type cable gland
IP68 protection (to 0.2 m), PBT / PA
- (3) PP
- (4) 1.4301 stainless steel, AISI 304

Accessories / Mounting examples

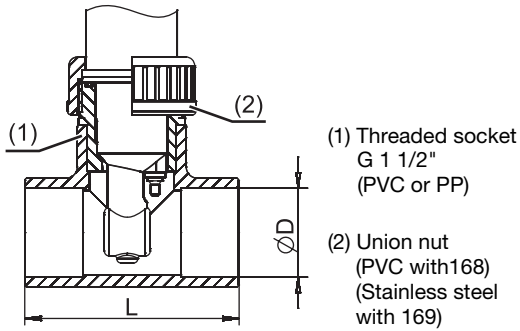

DN	ø D	L	Material	Maximum temperature	Part no.
32	40	98	PVC	60°C	00439247
40	50	118			00439249
32	40	88	PP	80°C	00449511
40	50	102			00449514
50	63	124			00449516

T-piece made from PVC or PP

suitable for process connections 168 and 169

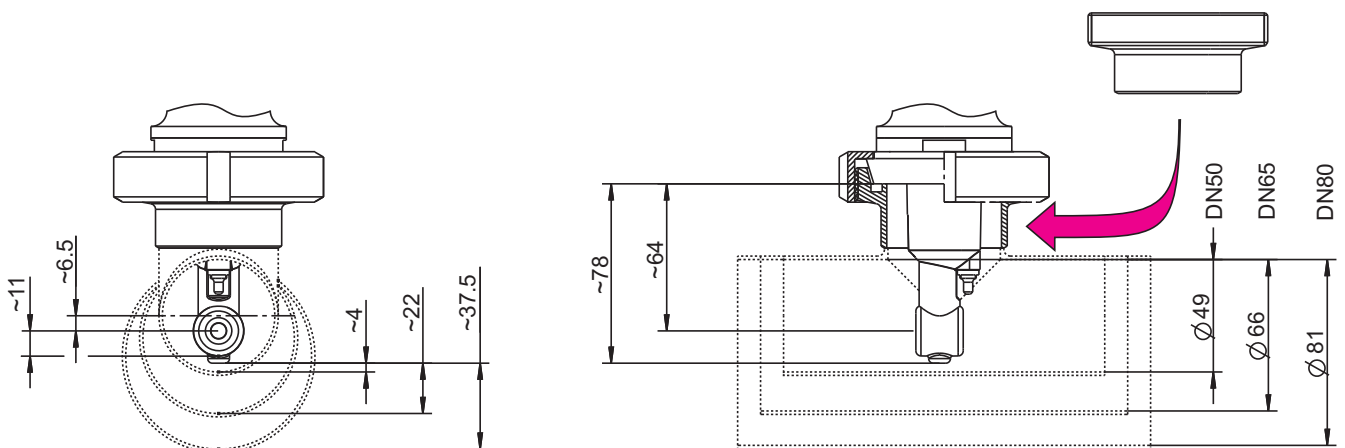

Weld-on threaded adapter DN50, DIN 11851

Part no. 00085020

suitable for process connection 607

The reducing T-piece shown, DIN, short, SSS, DN50/50, or DN65/50 or DN80/50, must be provided by the customer (not supplied by JUMO)!

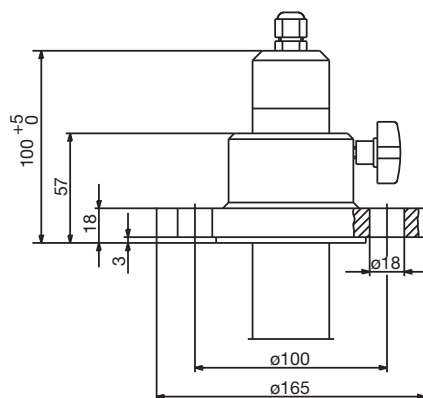

DN32 flange

suitable for process connection 706

Part no. 00083375

Material: PP

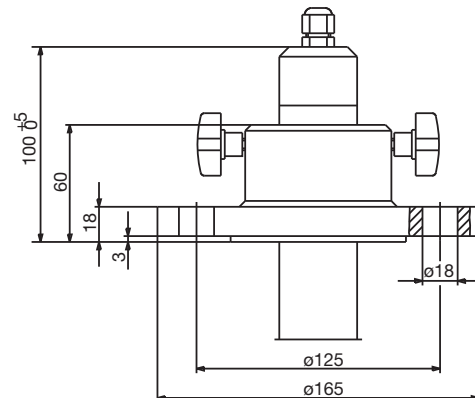

DN50 flange

suitable for process connection 706

Part no. 00083376

Material: PP

Order details: JUMO ecoLine Ci
Inductive conductivity and temperature sensor

(1) Basic type	
202943	JUMO ecoLine Ci Inductive conductivity and temperature sensor for general water engineering
(2) Basic type extension	
10	PP sensor body, external temperature sensor (standard)
20	PP sensor body, internal temperature sensor
30	PVDF sensor body, internal temperature sensor
(3) Process connection	
168	for T-piece installations, with PVC union nut G 1 1/2
169	for T-piece installations, with stainless steel union nut G 1 1/2
607	Taper socket with union nut DN 50 DIN 11851 (dairy pipe fitting) ^{a,b}
616	Clamping socket (clamp) DN 50 (2") DIN 32676 ^{a,b}
617	Clamping socket (clamp) 2.5" similar to DIN 32676 ^{a,b}
690	SMS DN 2" ^{a,b}
706	Immersion version ^b
(4) Immersion length (EL)	
0000	without
0500	EL = 500 mm ^c
1000	EL = 1000 mm ^c
1500	EL = 1500 mm ^c
2000	EL = 2000 mm (max. value) ^c
(5) Electrical connection	
21	Fixed cable with M12 cable socket
(6) Length of fixed cable	
10	10 m (standard)
20	20 m
30	30 m
(7) Extra codes	
000	none

^a Without mounting material (union nuts, retaining clamps, etc.)

^b For basic type extension 10 or 20 only.

^c For process connection 706 only.

Order code	(1)	/	(2)	-	(3)	-	(4)	-	(5)	-	(6)	/	(6)
Order example	202943	/	10	-	168	-	0000	-	21	-	10	/	000

Stock versions (delivery 3 working days after receipt of order)

Type	Description	Part no.
202943/10-168-0000-21-10/000	PP, external temperature sensor, with PVC union nut, 10 m fixed cable	00548189
202943/20-168-0000-21-10/000	PP, internal temperature sensor, with PVC union nut, 10 m fixed cable	00556950

Production versions (delivery 10 working days after receipt of order)

Type	Description	Part no.
202943/10-607-0000-21-10/000	PP, external temperature sensor, MK DN50, 10 m fixed cable	00550665
202943/10-706-1000-21-10/000	PP, external temperature sensor, immersion version 1 m, 10 m fixed cable	00556316

Accessories (delivery 3 working days after receipt of order)

Description	Part no.
Weld-on threaded adapter DN50, DIN 11 851(mating piece for process connection 607)	00085020
PVC DN32 T-piece, including threaded insert (mating piece for process connection 168 or 169)	00439247
PVC DN40 T-piece, including threaded insert (mating piece for process connection 168 or 169)	00439249
PP T-piece, DN32 ^a (mating piece for process connection 168 or 169)	00449511
PP T-piece, DN40 ^a (mating piece for process connection 168 or 169)	00449514
PP T-piece, DN50 ^a (mating piece for process connection 168 or 169)	00449516
G1 1/2 union nut, PVC	00439199
G1 1/2 union nut, stainless steel	00452039
DN50 grooved union nut, DIN 11 851	00343368
SMS DN2" grooved union nut	00345162
DN32 flange ^b , PP material	00083375
DN50 flange ^b , PP material	00083376
Calibration adapter for inductive conductivity measurement, type 202711/21	00543395

^a With rotation protection - the sensor can only be installed in the correct alignment.

^b In conjunction with sensor with process connection 706 (immersion version) only.

Note

The following are required for the initial commissioning of the sensor and transmitter/controller or when replacing components:

- Transmitter/controller e. g. JUMO AQUIS 500 Ci, data sheet 20.2566
- JUMO ecoLine Ci inductive conductivity and temperature sensor
- Calibration adapter for inductive conductivity measurement, type 202711/21, data sheet 20.2711