

JUMO AQUIS 500 CR

Transmitter/Controller for conductivity, TDS, resistivity and temperature

Compliant with
USP <645>



Type 202565

Brief description

The device is used for the conductive measurement/control of electrolytic conductivity, resistivity or the TDS value. In addition, the JUMO AQUIS 500 CR also offers the possibility of showing the measured conductivity according to a customer-specific table.

Conductive two-electrode cells as well as four-electrode cells can be connected to the device. Temperature serves as the second input variable, measured by a Pt100/1000 probe. Depending on the measured variable, it is therefore possible to implement specific, automatic temperature compensation.

The device is operated using keys and a large LC graphics display on which the measurements are clearly legible. The plain-text presentation of the parameters makes it easier for the user to configure the device, and also helps in programming it correctly.

Thanks to its modular design, the device can be perfectly matched to the particular application requirement. Up to four outputs are available (see the block diagram for the functions).

Typical areas of application

Universally applicable in water and wastewater engineering, service/process water and wastewater, drinking water and well/surface water, pure and high-purity water as well as for pharmaceutical water (e.g. as per USP, Ph.Eur., WFI), water quality measurements, TDS measurements (ppm or mg/l).

Key features

- Direct changeover to
 - conductivity ($\mu\text{S}/\text{cm}$ or mS/cm)
 - resistivity ($\text{k}\Omega \times \text{cm}$ or $\text{M}\Omega \times \text{cm}$)
 - TDS measurement (ppm or mg/l)
 - customer-specific table
- Automatic temperature compensation:
 - off (e.g. USP), linear, ASTM, natural water (EN 27888/ISO 7888)
- Large LC graphics display with background lighting
- Choice of display: large numbers, bar graph or trend display
- Calibration options according to measured variable: cell constant and temperature coefficient
- Calibration logbook
- Two-electrode cells (as standard) or four-electrode cells can be connected
- Pollution detection can be activated
- Auto-range operation
- IP67 enclosure protection (in surface mountable housing)
IP65 enclosure protection (for panel mounting)
- Language changeover: German, English, French; further languages can be loaded through the setup program
- Using the setup program: user-friendly programming, plant documentation, additional languages can be loaded

Block diagram

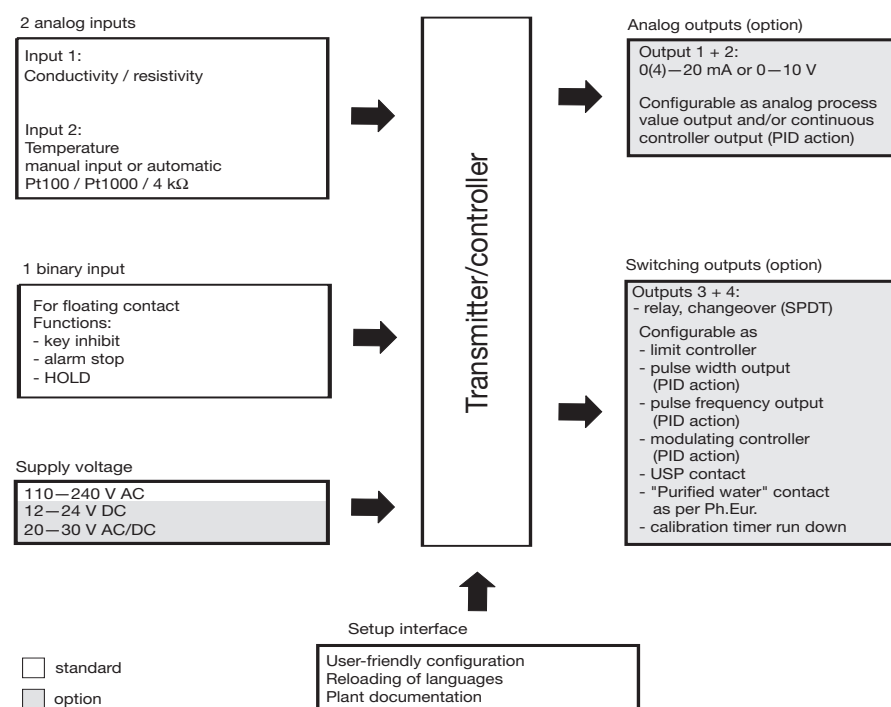

Approvals/approval marks (see Technical data)



Functional description

The device is designed for use on site. A rugged housing protects the electronics and the electrical connections from corrosive environmental conditions (IP67). As an alternative, the device can also be installed in a control panel, and is then protected to IP65 on the front. The electrical connection is made by easy-to-fit pluggable screw terminals.

Transmitter

Two-electrode cells (standard) as well as four-electrode cells can be used for measurement.

Two-electrode cells can be connected, in the usual increments for cell constants (K=0.01; 0.1; 1.0; 3.0 and 10.0). Thanks to the widely adjustable relative cell constant, it is also possible to connect sensors with different cell constants (e.g. K=0.2).

In the case of the 4-electrode cells, the values K=0.5 and 1.0 have been predefined for the cell constant. Here too, the device can be matched to sensors with different cell constants (e.g. K=0.4).

The device can perform automatic temperature compensation, by acquiring the temperature of the sample solution.

Displays and controls

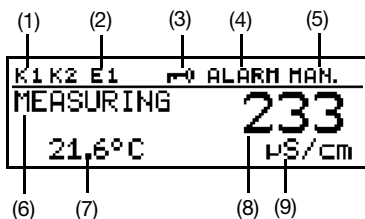

- (1) Switching output 1 or 2 is active
- (2) Binary input 1 is actuated
- (3) Keypad is inhibited
- (4) Alarm has been activated
- (5) device is in manual mode
- (6) device status
- (7) Temperature of medium
- (8) Principal measurement
- (9) Unit of principal measurement

The user can define what is to be shown in positions (7) and (8) of the display:

- no display
- compensated or uncompensated measurement
- temperature
- output level 1 or 2
- setpoint 1 or 2

Operation

For easy programming and operation, all parameters are arranged in clearly structured levels and shown in plain text. Operation is protected by a code word. This facilitates individual adaptation of the operation, since parameters can be generally enabled or specifically assigned to the protected area.

As an alternative to configuration from the keys, the device can also be configured through the convenient setup program for PC (option).

Display modes

Three display modes are available:

Large numbers

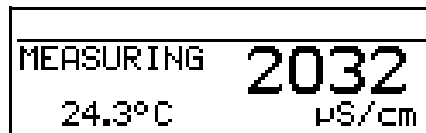

In this display mode, the measurements are shown in digits, as usual.

Trend display

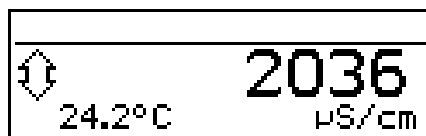

The numerical value is supplemented by a symbol which indicates the change direction and change speed of the measurement.

This can, for instance, be very useful during controller optimization.



from left to right:

fast, medium and slow rise, stable, slow, medium and fast fall.

Bar graph

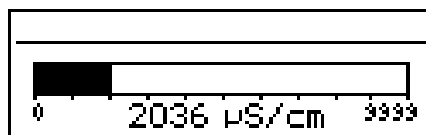

This display mode allows the user to see at a glance in which region the measurement is at present.

The bar graph can be freely scaled.

Function modes

Electrolytic conductivity

Display/control, unit µS/cm or mS/cm.

Resistivity (high-purity water)

Display/control, unit kΩ x cm or MΩ x cm.

TDS

Display/control with ppm for the unit.

In this mode, the specific TDS factor can be entered in addition.

Customer-specific table

In this mode, the input value (conductivity or resistivity) can be displayed in accordance with a table (up to 20 value pairs). Thanks to this function, it is possible to implement simple concentration measurements, for example. The values in the table can only be entered through the optional setup program.

Calibration

Cell constant

Because of manufacturing tolerances, the cell constant of a conductivity cell may deviate slightly from its nominal value. In addition, the cell constant may change during operation (due to deposits or wear, for example). This results in a change of the output signal from the cell. The device provides the user with the possibility of compensating any deviation from the nominal value of the cell constant by manual entry or automatic calibration of the relative cell constant. A manual entry is used, for instance, for calibration during high-purity water measurement.

Temperature coefficient

The conductivity of almost all solutions depends on the temperature. To ensure correct measurement, it is therefore necessary to know both the temperature and the temperature coefficient [%/°C] of the sample solution. The temperature can either be measured automatically, with a Pt100 or Pt1000 temperature probe, or it has to be set manually by the user.

The temperature coefficient can be automatically determined by the device, or it can be entered manually.

Calibration logbook

The five most recent successful calibrations can be called up in the calibration logbook. This makes it possible to evaluate the ageing of the sensor that is connected.

Calibration timer

The calibration timer indicates (if required) when the next routine calibration is due. The calibration timer is activated by entering a number of days, after which recalibration has to be carried out (plant or operator requirement).

MIN / MAX value memory

This memory acquires the minimum or maximum input variables that have occurred. This information serves, for example, to decide whether the sensor that is connected is suited to the values that are actually present.

Detection of deposits

Deposit detection can be activated for 4-electrode cells.

During normal operation, it can happen that deposits form on electrodes. This has the result that a lower concentration is displayed than actually present. With activated "deposit detection" function, the device tells you when the cell needs to be serviced.

Auto-range

For some processes, the availability of two measuring ranges is advantageous, for instance for rinsing or regeneration processes.

What is usually required here, is the precise acquisition of a low conductivity. Rinsing or regeneration, however, involves a much higher conductivity, which could lead to an out-of-range condition (error). This situation is not just unsatisfactory, but may even be dangerous. Thanks to the auto-range function, two measuring ranges can be determined. The device then switches between them in a defined manner.

Binary input

The following functions can be activated through the binary input:

- Activate key inhibit
When this function has been activated, operation from the keys is no longer possible.
- Activate HOLD mode
After activating this function, the outputs (analog and relay) adopt the states that have previously been defined.
- Alarm suppression (controller alarm only)
This function temporarily deactivates the alarm generation via the relay (has to be configured accordingly).

Linking the corresponding terminals by means of a floating contact (e. g. relay) will activate the pre-defined function.

Analog Outputs

There are up to 2 analog outputs available.

The following functions can be selected:

Output	Analog process value output		Continuous controller main value
	Main variable	Temperature	
1	X	-	X
2	-	X	X

With the analog process value output, the range start and end values are freely selectable. The response of the outputs to over/underrange, alarm and calibration is freely programmable. Simulation function: The analog process value outputs can be freely set in the manual ("Hand") mode.

Application: "Dry run" start-up of the plant, troubleshooting, servicing.

Control functions

The relays can have functions assigned that are configured via parameters. The control function is freely programmable as P, PI, PD or PID action.

Relay outputs

Two relay changeover contacts are available for the principle measurement variable and/or temperature.

The following functions can be programmed:

- Switching direction (min/max)
- Limit controller (pull-in/drop-out delay, hysteresis)
- Pulse width output (see control functions)
- Pulse frequency output (see control functions)
- Modulating controller function (see control functions)
- Limit comparators (pull-in/drop-out delay, hysteresis)
- Pulse function
The output switches on briefly when reaching the switching point and then off again.
- Alarm
- Sensor or range error
- Response to alarm, over/underrange, calibration and HOLD

Contact functions

MAX limit comparator

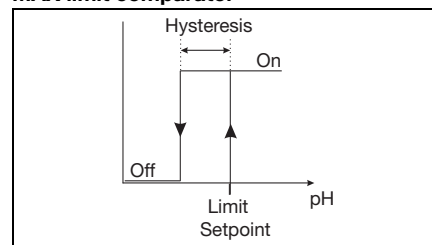

MIN limit comparator

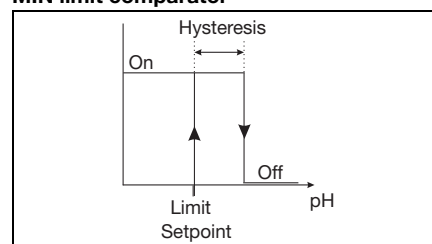

Alarm window 1

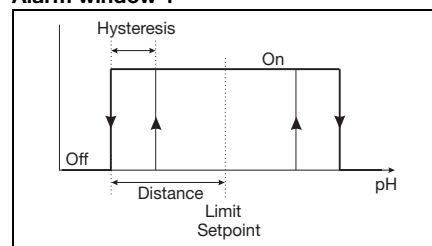

Alarm window 2

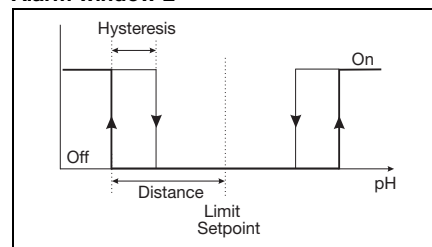

Pulse contact

Trigger condition longer than pulse duration

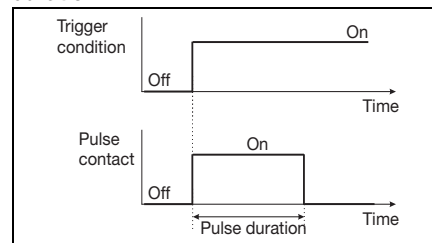

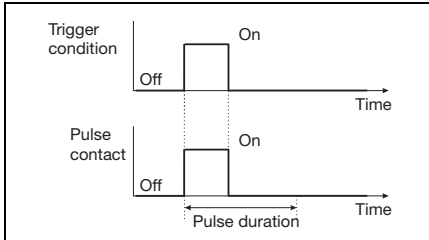
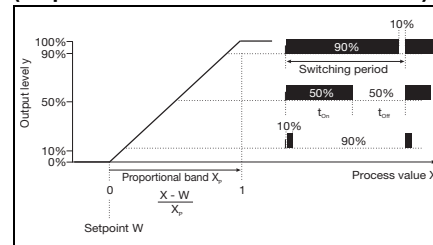
Pulse contact
Trigger condition shorter than pulse duration

Pulse width controller
(output is active with $X > W$ and P action)

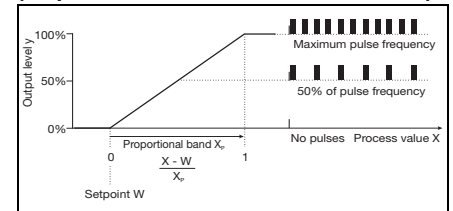
If the process value X exceeds the setpoint W , the P controller will control proportionally to the control deviation. On going outside the proportional band, the controller operates with an output level of 100 % (100 % duty cycle).

Pulse frequency controller
(output is active with $X > W$ and P action)

If the process value X exceeds the setpoint W , the P controller will control proportionally to the control deviation. On going outside the proportional band, the controller operates with an output level of 100 % (maximum switching frequency).

Measuring ranges / cell constants

This state-of-the-art device offers a far wider dynamic range on the input side than can be managed physically or chemically by the conductivity cells. For this reason, the range must be matched to the operating range of the cell.

Examples of ranges for combination with 2-electrode cells

Cell constant (K)	Recommended/practical measuring span (depending on the conductivity cell)
0.01 1/cm	0.05 $\mu\text{S}/\text{cm}$ to 20 $\mu\text{S}/\text{cm}$
0.1 1/cm	1 $\mu\text{S}/\text{cm}$ to 1000 $\mu\text{S}/\text{cm}$
1.0 1/cm	0.01 mS/cm to 100 ms/cm
3.0 1/cm	0.1 mS/cm to 30 ms/cm
10.0 1/cm	0.1 mS/cm to 200 ms/cm

Example

A measurement is to be carried out in the 10 $\mu\text{S}/\text{cm}$ to 500 $\mu\text{S}/\text{cm}$ range. A conductivity cell with the cell constant $K = 0.1$ 1/cm is chosen.

The unit $\mu\text{S}/\text{cm}$ without a decimal place is configured on the device.

Combination with 4-electrode cells and 2-electrode cells having cell constants that deviate from the above graduation

This requires taking a closer look at the device technology and considering both the uncompensated and the temperature-compensated measuring span.

The uncompensated measuring span of the device is calculated according to the formula:
 Measuring span = 0.1 $\mu\text{S}/\text{cm}$ x cell constant (K) to 2500 mS x cell constant (K).

After taking account of the temperature compensation range, the following compensated measuring span (approx.) will remain:

Measuring span = 0.1 $\mu\text{S}/\text{cm}$ x cell constant (K) to 1250 mS x cell constant (K).

Cell constant (K)	Measuring span covered by device (temperature-compensated)
0.01	0.001 $\mu\text{S}/\text{cm}$ to 1.25 ms/cm
0.1	0.01 $\mu\text{S}/\text{cm}$ to 12.5 ms/cm
1.0	0.1 $\mu\text{S}/\text{cm}$ to 125 ms/cm
3.0	0.3 $\mu\text{S}/\text{cm}$ to 375 ms/cm
10.0	0.1 mS/cm to 1250 ms/cm

It is assumed that the measuring span of the device is always larger than the recommended or practically usable range of the conductivity cell.

The smaller range (device or conductivity cell) determines the maximum range that can be used.

Example

Which span can the device cover with a predefined cell constant?

The predefined cell constant is $K=0.4$

The span of the device is

0.1 $\mu\text{S}/\text{cm}$ x 0.4 1/cm to

1250 mS/cm x 0.4 1/cm

→ 0.04 $\mu\text{S}/\text{cm}$ — 500 mS/cm

Technical data

Inputs

Principal input	Indication range	Accuracy	Temperature error
$\mu\text{S/cm}$	0.000 v 9.999 00.00 to 99.99 000.0 to 999.9 0000 to 9999	$\leq 0.6\%$ of range + 0.3 μS x cell constant (K)	0.2 %/10 °C
mS/cm	0.000 to 9.999 00.00 to 99.99 000.0 to 999.9 0000 to 9999	$\leq 0.6\%$ of range + 0.3 μS x cell constant (K)	0.2 %/10 °C
k Ω x cm	0.000 to 9.999 00.00 to 99.99 000.0 to 999.9 0000 to 9999	$\leq 0.6\%$ of range + 0.3 μS x cell constant (K)	0.2 %/10 °C
M Ω x cm	0.000 to 9.999 00.00 to 99.99 000.0 to 999.9 0000 to 9999	$\leq 0.6\%$ of range + 0.3 μS x cell constant (K)	0.2 %/10 °C
Secondary input	Measuring range	Accuracy	Temperature error
Temperature Pt100 (automatic detection)	-50 to +250 °C ^a	$\pm 0,5$ K (up to 100 °C)	0.05 %/10 °C
Temperature Pt1000 (automatic detection)		$\pm 0,8$ K (as of 100 °C)	
Temperature NTC/PTC	max. 4 kOhm Input via table with 20 value pairs, through setup program	$\leq 0.3\%$ ^b	0.05 %/10 °C

^a Switchable to °F

^b Depending on interpolation points.

Temperature compensation

Type of compensation	Range ^a
Linear 0 to 8 %/°C	-10 to 160 °C
ASTM D1125 - 95 (high-purity water)	0 to 100 °C
Natural water (ISO 7888)	0 to 36 °C
Reference temperature	
adjustable from 15 to 30 °C; preset to 25 °C (standard)	

^a Please note operating temperature range of sensor.

Measuring circuit monitoring

Inputs	Over/underrange	Short-circuit	Cable break
Conductivity	yes	depending on range	depending on range
Temperature	yes	yes	yes

2-electrode systems

Cell constant [1/cm]	Setting range of relative cell constant	Resulting usable range [1/cm]
0.01	20 to 500 %	0.002 to 0.05
0.1		0.02 to 0.5
1.0		0.2 to 5
3.0		0.6 to 15
10.0		2.0 to 50

4-electrode systems

Cell constant [1/cm]	Setting range of relative cell constant	Resulting usable range [1/cm]
0.5	20 to 150 %	0.1 to 0.75
1.0		0.2 to 1.5

Binary input

Activation	through floating contact
Function	key inhibit HOLD alarm suppression

Controller

Controller type	limit comparators, limit controller, pulse width controller, pulse frequency controller, modulating controller, continuous controller
Controller action	P/PI/PD/PID
A/D converter	dynamic resolution up to 14-bit
Sampling time	500 msec

Analog outputs (one or two)

Output mode	Signal range	Accuracy	Temperature error	Permissible load resistance
Current signal	0/4 to 20 mA	≤ 0.25 %	0.08 %/10 °C	≤ 500 Ω
Voltage signal	0 to 10 V	≤ 0.25 %	0.08 %/10 °C	≥ 500 Ω

The analog outputs respond in accordance with the recommendation as per NAMUR NE43.
They are electrically isolated, AC 30 V/DC 50 V.

Switching outputs (two changeover (SPDT) max.)

Rated load	3 A/250 VAC (resistive load)
Contact life	>2x10 ⁵ operations at rated load

Setup interface

Interface for configuring the device through the optionally available setup program (for device configuration only).

Electrical data

Supply voltage	AC 110 to 240 V; -15/+10 %; 48 to 63 Hz AC/DC 20 to 30 V; 48 to 63 Hz DC 12 to 24 V; +/-15 % (permissible only for connection to SELV/PELV circuits)
Power consumption	approx. 14 VA
Electrical safety	EN 61 010, Part 1 overvoltage category III ^a , pollution degree 2
Data backup	EEPROM
Electrical connection	pluggable screw terminals conductor cross-section up to 2.5 mm ² (supply, relay outputs, sensor inputs) conductor cross-section up to 1.5 mm ² (analog outputs)

^a Not valid with protective extra-low voltage (PELV) of power supply variant DC 12 to 24 V.

Display

Graphics LC display	120 x 32 pixels
Background lighting	programmable: - off - on for 60 seconds during operation

Housing

Material	ABS
Cable entry	cable glands, 3xM16 and 2xM12 max.
Special feature	venting device to prevent condensation
Ambient temperature range (the specified accuracy is adhered to within this range)	-10 to +50°C
Operating temperature range (device is operational)	-15 to +65°C
Storage temperature range	-30 to +70°C
Climatic conditions	rel. humidity ≤ 90 % annual mean, no condensation (following EN 60721 3-3 3K3)
Enclosure protection as per EN 60529	in surface mountable housing: IP67 for panel mounting: IP65 front, IP20 rear
Vibration strength	as per EN 60068-2-6
Weight	surface mountable housing: approx. 900 g for panel mounting: approx. 480 g
Dimensions	see dimensioned drawings on page 10.

Standard accessories

Cable glands
Internal mounting material
Operating Instructions

Approvals/approval marks

Mark of conformity	Testing laboratory	Certifikates/certification numbers	Test basis	valid for
c UL us	Underwriters Laboratories	E 201387	UL 61010-1	all versions

Connection diagram

The connection diagram in the data sheet provides preliminary information about the connection options. For the electrical connection, only use the installation instructions or the operating manual. The knowledge and the correct technical execution of the safety information/instructions contained in these documents are mandatory for mounting, electrical connection, startup, and for safety during operation.

The electrical connection for the “surface mountable housing” version can be made easily, after opening the unit.

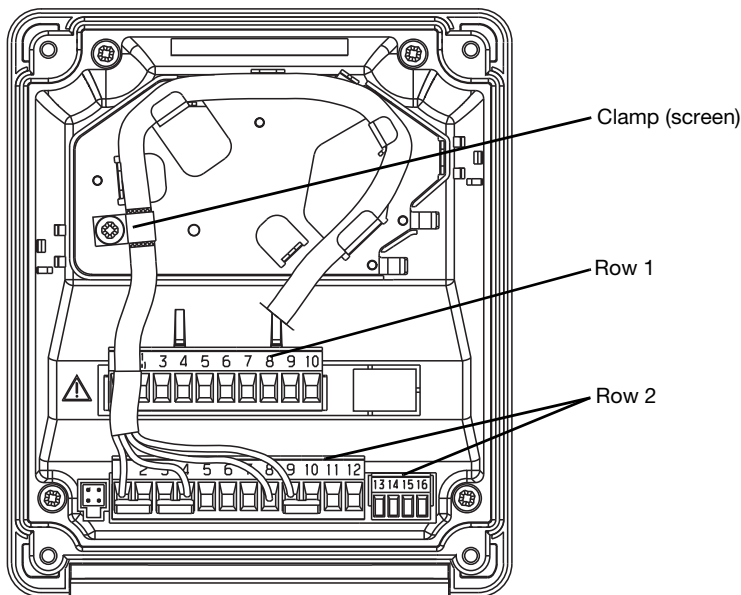
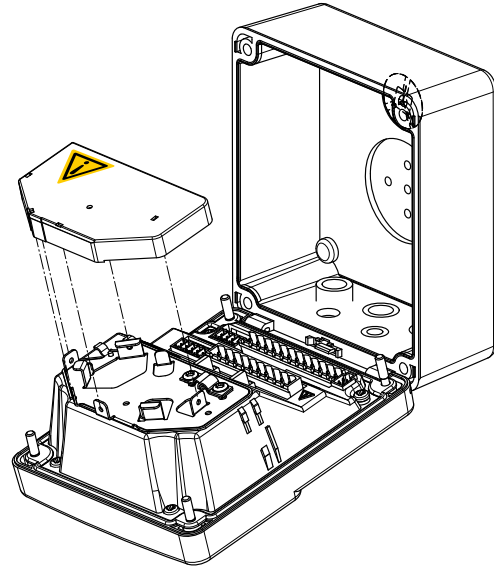

The connection cable between sensor and transmitter must be a screened cable with a diameter of 8 mm max. The device contains a guide plate for an optimized cable routing. The sensor cables (incorporating strain relief) are run to the pluggable screw terminals where they are connected without using any solder.

Connection		Terminal	Row
Supply for transmitter/controller			
Supply voltage (23): AC 110 to 240 V; -15/+10 %; 48 to 63 Hz		1 N (L-)	1
Supply voltage (25): AC/DC 20 to 30 V; 48 to 63 Hz		2 L1 (L+)	
Supply voltage (30): DC 12 to 24 V; +/-15 %			
NC		3	

Connection		Terminal	Row
Inputs			
Conductivity cell (2-electrode system) Terminals 1+2 and 3+4 are linked in the device; 2-wire cable routed to the head of the conductivity cell. For concentric cells, terminal 1 is connected to the outer electrode.		1 2 3 4	2
Conductivity cell (2-electrode system) Wiring for the highest accuracy; 4-wire cable routed to the head of the conductivity cell. For concentric cells, terminal 1 is connected to the outer electrode.		1 2 3 4	
Conductivity cell (4-electrode system) 1 - outer electrode 1 (I hi) 2 - inner electrode 1 (U hi) 3 - inner electrode 2 (U lo) 4 - outer electrode 2 (I lo)		1 2 3 4	
NC		5 6 7	
RTD in 2-wire circuit		8 9 10	
RTD in 3-wire circuit		8 9 10	
Binary input		11 12	
Outputs			
Analog output 1 0 to 20 mA or 20 to 0 mA or 4 to 20 mA or 20 to 4 mA or 0 to 10 V or 10 to 0 V (electrically isolated)		+ 13 - 14	2
Analog output 2 0 to 20 mA or 20 to 0 mA or 4 to 20 mA or 20 to 4 mA or 0 to 10 V or 10 to 0 V (electrically isolated)		+ 15 - 16	
Switching output K1 (floating)		4 common 5 break (SPST-NC) 6 make (SPST-NO)	1
NC		7	
Switching output K2 (floating)		8 common 9 break (SPST-NC) 10 make (SPST-NO)	

Dimensions

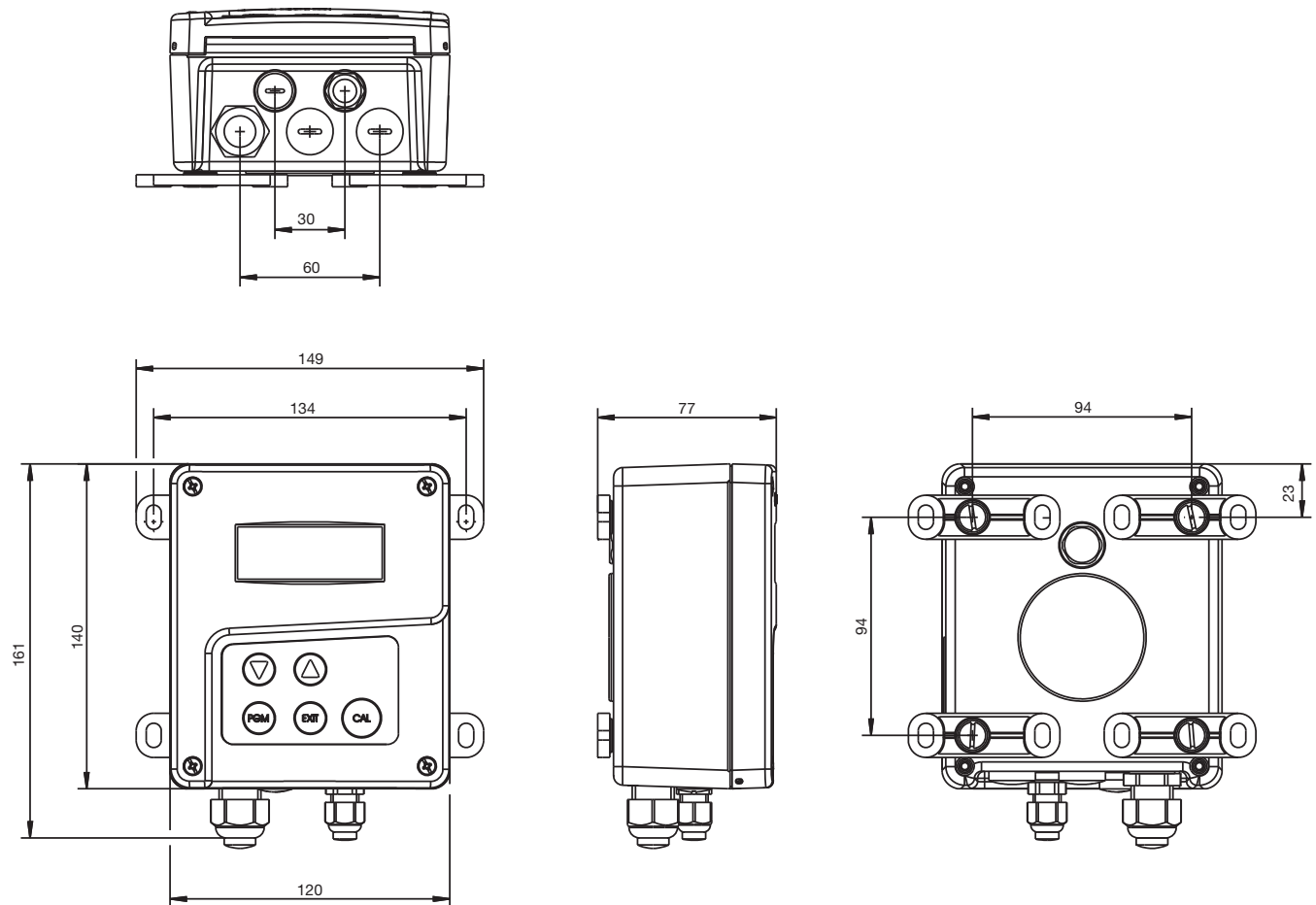

Panel-mounting/drilling diagram

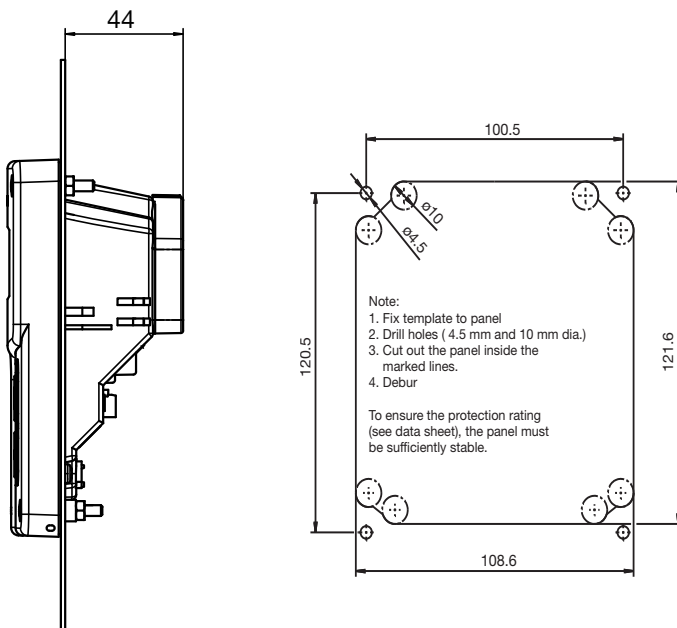

Note:
The drilling template is shown in its actual size in the Operating Instructions B 202565.0.

Accessories

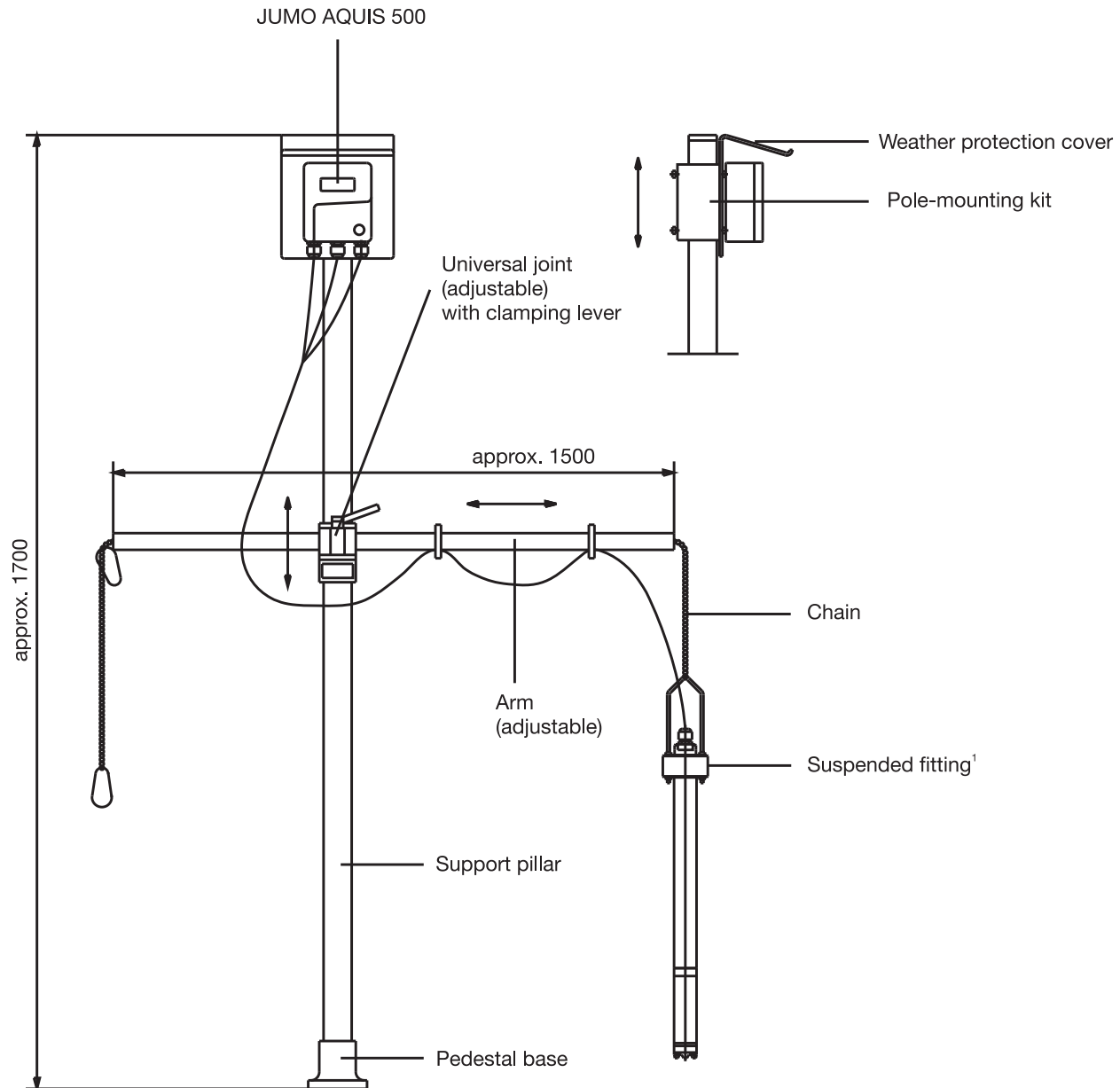

¹ The suspended fitting consists of a fixing 20/00453191 (see accessories) and a cell with a suitable fitting (see data sheet 202922, for example).

Order details: JUMO AQUIS 500 CR

(1) Basic type	
202565	JUMO AQUIS 500 CR - Transmitter/controller for conductivity, TDS, resistivity and temperature
(2) Basic type extensions	
10	for panel mounting
20	in surface mountable housing
(3) Output 1 (for principle measurement variable or continuous controller)	
000	no output
888	analog output 0(4) to 20 mA or 0 to 10 V
(4) Output 2 (for principle measurement variable or continuous controller)	
000	no output
888	analog output 0(4) to 20 mA or 0 to 10 V
(5) Output 3	
000	no output
310	relay with changeover (SPDT) contact
(6) Output 4	
000	no output
310	relay with changeover (SPDT) contact
(7) Supply voltage	
23	AC 110 to 240 V; +10 %/-15 %, 48 to 63 Hz
25	AC/DC 20 to 30 V, 48 to 63 Hz
30	DC 12 to 24 V; ±15 %
(8) Extra codes	
000	none

Order code (1) (2) (3) (4) (5) (6) (7) (8) , ...
Order example 202565 / 20 - 888 - 000 - 310 - 000 - 23 / 000

Stock items (shipment: 3 working days after receipt of order)

Type	Part no.
202565/20-888-888-310-310-23/000	00480055
202565/20-888-000-310-000-23/000	00480054

Accessories (shipment: 10 days after receipt of order)

Type	Part no.
Protective roof for JUMO AQUIS 500 ^a	00398161
Pipe installation set for JUMO AQUIS 500 ^b	00483664
DIN rail installation set for JUMO AQUIS 500 ^c	00477842
Support pillar with base clamp, arm and chain	00398163
Holder for suspension fitting	00453191
Back panel set 202560/65	00506351
PC setup software	00483602
PC interface cable including USB/TTL converter and two adapters (USB connecting cable)	00456352

^a The pole-mounting kit is needed for mounting the protection cover.

^b With the pipe installation set, the JUMO AQUIS 500 can be attached to a pipe (e. g. a support pillar or a railing).

^c With the DIN rail installation set, the JUMO AQUIS 500 can be attached to a 35 mm x 7.5 mm DIN rail as per EN 60715 A.1.