

PyroMiniBus

Infrared Temperature Sensors with RS485 Modbus for Multi-Channel Installations



- Miniature non-contact temperature sensors
- RS485 Modbus communications - sensors can be connected directly to third-party Modbus hardware
- Optional Calex touch screen terminal for configuration, display, alarms and data logging
- Low-cost standalone 6-channel system
- Connect to larger systems using the PM180's separate Modbus Master and Slave interfaces
- Analogue and alarm relay outputs via optional modules
- Conforms to industrial EMC standards
- Ideal for continuous temperature monitoring at multiple locations e.g. busbar surface temperature in switchgear cabinets

PM180 AS MODBUS MASTER

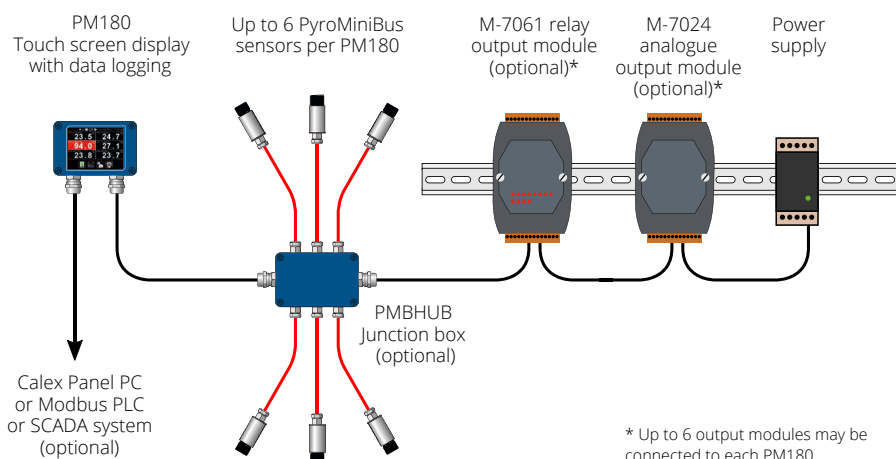

PyroMiniBus sensors are designed to measure the surface temperature of non-reflective materials in industrial applications, from -20°C to 1000°C.

Sensors have direct RS485 Modbus communications, allowing them to be connected directly to third-party Modbus hardware.

They are sealed to IP65, built from 316 stainless steel, and fully tested to industrial EMC standards.

They can measure food, paper, thick plastics, asphalt, paint, bulk materials and organic materials, as well as most dirty, rusty or oily surfaces.

ROBUST

PyroMiniBus sensors have an operating temperature rating of up to 120°C with no need for cooling.

COMPACT

The sensors measure just 45 mm long (plus cable gland), so they can fit into the smallest of spaces.

CONFIGURABLE

Up to 6 sensors can be connected to the optional PM180 interface module, which provides temperature display, configuration, and high-capacity data logging to a MicroSD Card.

Analogue and relay outputs are available via separate DIN rail mounted modules.

LOW COST

With up to 6 sensors connected to one PM180, the PyroMiniBus is an ideal low-cost non-contact temperature measurement system.

NETWORKABLE

PyroMiniBus sensors and PM180 sub-networks may be connected directly to an RS485 Modbus SCADA system or PLC. It is possible to measure the temperature of hundreds of locations on the same network.

PM180 AS MODBUS SLAVE

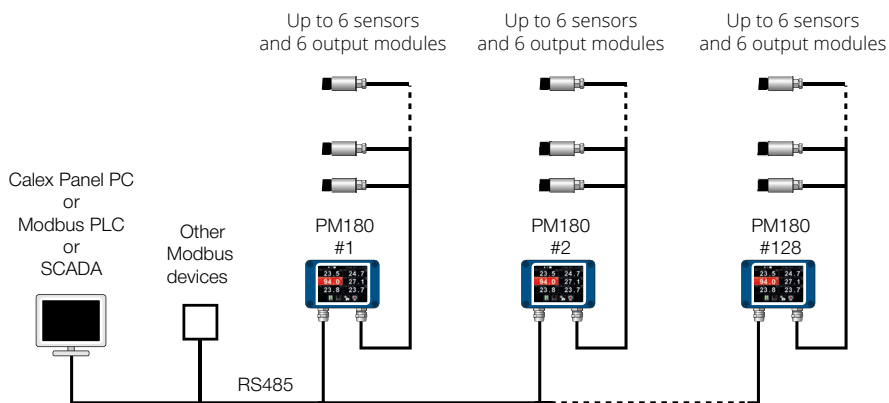

Each PM180 is a slave device on the main network and the master on each network of sensors. Up to 128 PM180 units can be connected to the same Modbus Master. This layout allows hundreds of sensors to be connected in a network.

PM180

Optional 6-Channel Touch Screen Terminal

- Configure, display and log data and alarm events
- Connect up to 6 sensors per terminal unit
- Operates as Modbus Master and Slave
- High capacity data logging to MicroSD Card
- Bright touch screen display with backlight
- Analogue and relay outputs via optional ICPDAS modules M-7061 and M-7024
- 2-channel scrolling temperature chart
- Selectable language: English, Chinese, Japanese

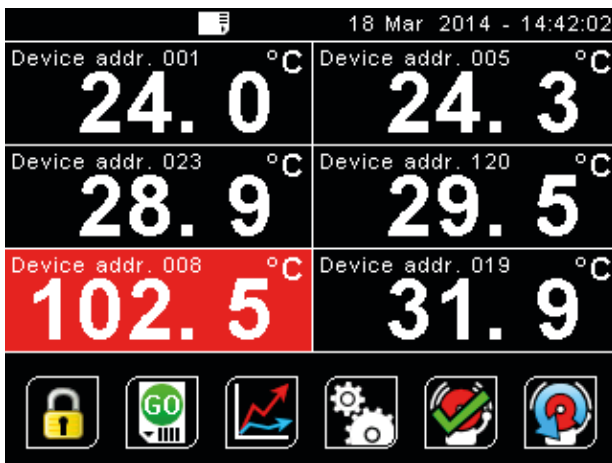

Intuitive touch screen interface

Display and configure all 6 channels individually or simultaneously. The display for each channel turns red in an alarm condition

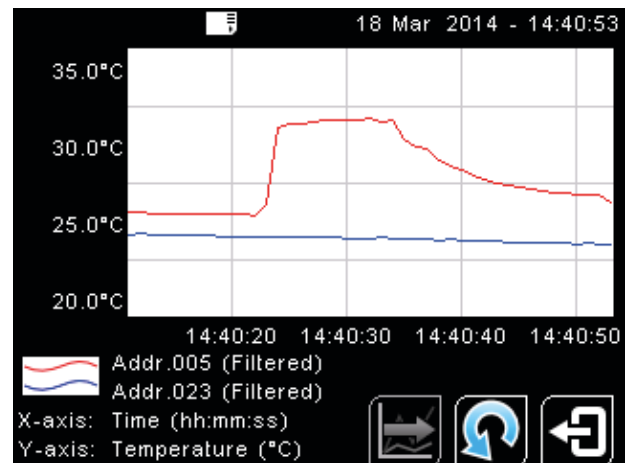

Temperature chart

Display temperature data from two channels in a scrolling graph



Password-protected settings

Configure options for each sensor, and the PM180 itself, via the touch screen interface

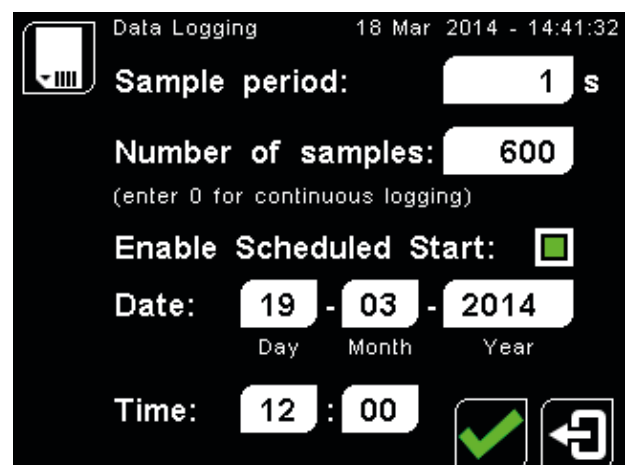

Data logging

Schedule a start time, or start and stop logging at the touch of an icon. Temperature data and alarm events may be logged to a MicroSD Card (not supplied)

SPECIFICATIONS



PYROMINIBUS SENSOR SPECIFICATIONS

General	
Temperature Range	-20°C to 1000°C
Interface	RS485 Modbus RTU
Accuracy	±1% of reading or ±1°C whichever is greater
Repeatability	± 0.5% of reading or ± 0.5°C whichever is greater
Emissivity Setting	0.2 to 1.0
Response Time	125 ms (90% response)
Spectral Range	8 to 14 μm
Supply Voltage	24 V DC (min. 6 V DC / max. 28 V DC)
Supply Current	50 mA max.
Baud Rate	9600 baud *
Format	8 data bits, no parity, 1 stop bit *

* Other configurations available on request

Configuration	
Configuration Method	Via PM180 touch screen, or directly via RS485 Modbus
Configurable Parameters	Emissivity Setting, Averaging, Reflected Energy Compensation
Mechanical	
Construction	Stainless Steel
Dimensions	18 mm diameter x 45 mm long
Thread Mounting	M16 x 1 mm pitch
Cable Length	1m (can be extended or ordered with longer length)
Weight with Cable	85 g
Environmental	
Environmental Rating	IP65
Ambient Temperature	0°C to 120°C
Relative Humidity	95% max. non-condensing
Conformity	
See PM180 Specification (right)	
Network Size	
Max. No. of Devices	247 sensors per Modbus Master

OPTICS

Diameter of target spot measured versus distance from sensing head (90% energy)

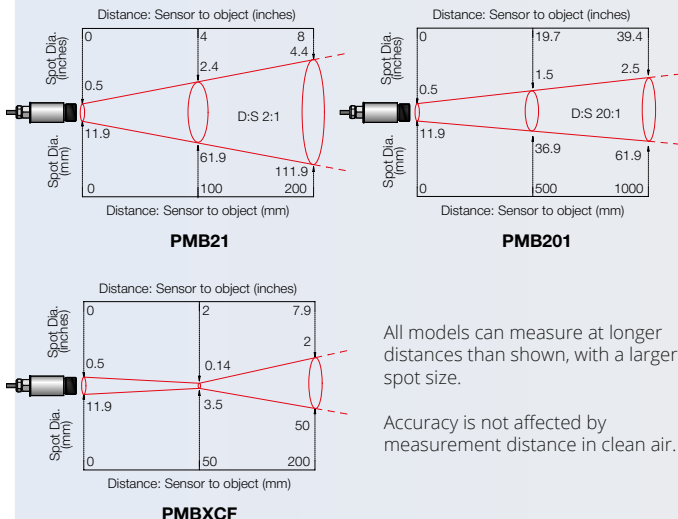

All models can measure at longer distances than shown, with a larger spot size.

Accuracy is not affected by measurement distance in clean air.



PM180 SPECIFICATIONS

General	
Compatible Sensor Types	All models of PyroMiniBus and PyroBus sensors; -BB and -BRT models of PyroMini and FibreMini sensors. Up to 6 sensors per PM180.
Display	2.83" (72 mm) resistive touch TFT, 320 x 240 pixels, backlit
Supply Voltage	24 V DC (min. 10 V DC / max. 30 V DC)
Maximum Current Draw	100 mA
Configurable Parameters (global)	Temperature units, date and time, data logging, graph channels, alarm logging
Configurable Parameters (per channel)	Signal processing, emissivity setting, reflected energy compensation, alarms, Modbus address
Alarm Configuration	12 alarms (2 per sensor) with adjustable level, individually configurable as HI or LO.
Temperature Units	°C or °F selectable
Temperature Resolution	0.1°
Signal Processing	Averaging with configurable period
Display Sample Period	120 ms per sensor (720 ms in total for 6 sensors)
Data Logging	
Logging Interval	1 to 86,400 seconds (1 day)
MicroSD Card	Max. capacity: 32 GB (not included - stores years of logged data)
Internal Clock Battery	1 x BR 1225 3V (not included)
Variables Logged	Target temperature, sensing head temperature, alarm events
File Format	.csv (can be imported to Excel)
Configurable Parameters	Sample period, number of samples, scheduled start date and time
Mechanical	
Construction	Die Cast Aluminium
Electrical Connections	Removable screw terminals, 28 AWG to 18 AWG
Dimensions	98 (w) x 64 (h) x 36 (d) mm excluding cable glands
Weight	280 g
Environmental	
Environmental Rating	IP65
Ambient Temperature	0°C to 60°C
Relative Humidity	Maximum 95%, non-condensing
Conformity	
RoHS Compliant	Yes
Electromagnetic Compatibility	EN61326-1, EN61326-2-3 (Electrical Equipment for Measurement, Control and Laboratory Use - EMC Requirements - Industrial)
Language	
Languages	Selectable: English, Chinese (Simplified) or Japanese
Network Size	
Max. No. of Devices	6 sensors per PM180 128 PM180 units per Modbus Master

MAJOR DIMENSIONS

PM180

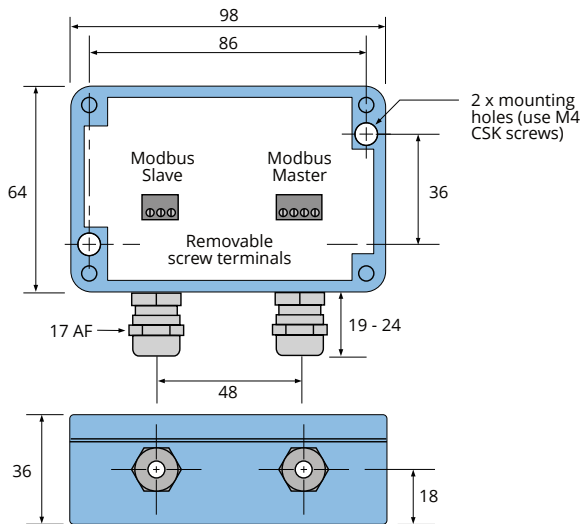

PMBHUB Junction Box

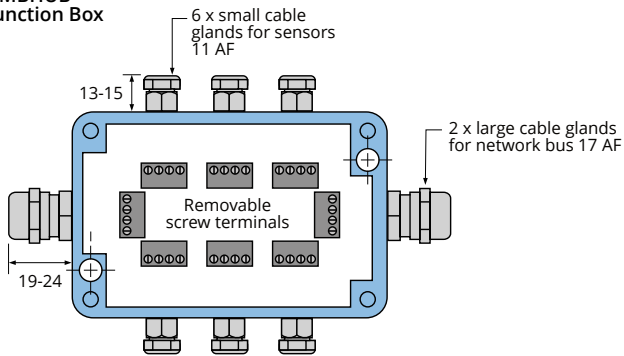

All dimensions in mm

PyroMiniBus Sensor

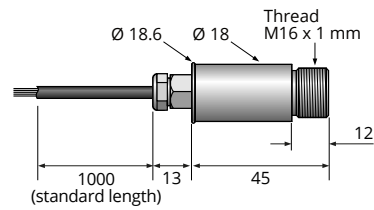

Mounting Nut (included)

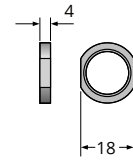

Air Purge Collar

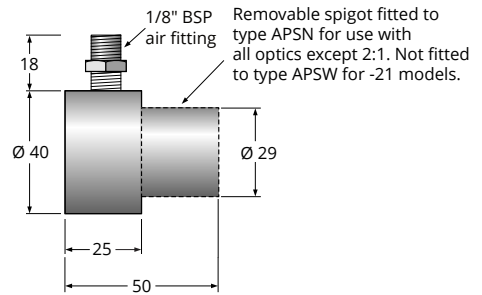

PMBHUB SPECIFICATIONS

Construction	Die Cast Aluminium
Electrical Connections	Removable screw terminals, 28 AWG to 18 AWG
Weight	250 g
Environmental Rating	IP65
Enclosure Dimensions	Same as PM180
Max. Ambient Temperature	80°C

SENSOR MODEL NUMBERS



PMB **201** - **3M**

Cable length (blank) 1 metre
nM n metres
 Maximum factory fitted length: 30 m
 Can be extended using RS485 cable

Field of view
21 2:1 wide-angle divergent optics
201 20:1 general-purpose divergent optics
XCF Close Focus optics (3.5 mm spot diameter at 50 mm distance)

Series
PMB PyroMiniBus sensor

SENSOR ACCESSORIES

PMBHUB	IP65 junction box for 6 sensors
FBS / ABS	Fixed or Adjustable mounting bracket
DLSBFS / DLSBAS	Fixed or Adjustable mounting bracket with continuous laser sighting
LSTS	Removable laser sighting tool
PMBSC	RS485 network cable (connects PM180 to PMBHUB)
CALCERTA	Calibration certificate
PMK	Panel Mounting Kit for PM180
PWS / SIWS	Protective plastic/silicon window in stainless steel holder

PM180 ACCESSORIES

MSD	MicroSD Card for PM180 data logging
M-7061	12-channel ICP DAS Modbus relay output module
M-7024	4-channel ICP DAS Modbus voltage or current analogue output module

