

FO 510

The **CS INSTRUMENTS Moisture in Oil Transmitter FO510** with two analog outputs for different measured variables and RS 485 Modbus interface as standard, enables reliable and long-term stable measurement in technical oils. Designed for measurements such as moisture content in transformer oil, motor oil, lubricating oil, hydraulic oil and diesel fuels. In addition to a highly accurate measurement of water activity (a_w) as well as temperature (T), the FO 510 calculates the absolute water content (x) in PPM.



Teile-Nr.: 02000xxxx

Inhalt

1	Foreword	3
2	Intended use.....	3
3	Safety instructions	4
4	Description	4
5	Technical data	6
6	Abmessungen / elektr. Anschluss.....	7
7	Installationshinweise	8
8	Modbus.....	9
8.1	Register Mapping der Werte-Register:.....	9
8.2	Geräte Einstellungs-Register	10
	Modbus Settings (2001...2006)	10
8.3	Analog Scaling Settings (2007...2011).....	10
9	Kalibrierung / Justage.....	11
10	Garantie	Fehler! Textmarke nicht definiert.

1 Foreword

Dear Customer,

Thank you for choosing the FO 510. Please read these installation and operating instructions carefully before mounting and commissioning and follow our instructions. The FO 510 will only function properly and operate safely if the instructions and notes described are strictly observed. Water content (x) in PPM.

2 Intended use

The FO510 is intended for measuring moisture in technical oils.

A check whether the device is suitable for the selected application must be carried out by the user. It must be ensured that the medium is compatible with the wetted parts. The technical data listed in the data sheet are binding.

Improper handling or operation outside the technical specifications is not permitted. Claims of any kind due to improper use are excluded.

Translated with www.DeepL.com/Translator (free version)

3 Safety instructions



Before installing the FO 510, read these operating instructions carefully. Failure to follow the instructions in this manual, in particular the safety instructions, may result in danger to personnel, equipment and installations..

- The product may only be used and applied in accordance with its intended use.
- Installation of the dew point sensor (oil humidity sensor) and maintenance work may only be carried out by trained personnel.
- Installation and service work must be carried out in a de-energized state.
- The applicable safety regulations must be observed!
- Attention: max. pressure range 300 bar must not be exceeded.
- Observe the measuring ranges of the sensor!
Overheating will destroy the sensors.
- Observe the permissible storage and transport temperature as well as the permissible operating temperature (e.g. protect the measuring device from direct sunlight).
- Opening the device, improper handling or use of force will void the warranty!

4 Description

The FO 510 enables reliable and long-term stable moisture measurement in technic

Moisture in oil can be measured and expressed in two different ways: as an absolute value or as a relative value.

- Relative moisture is expressed by water activity (a_w). Water activity is a relative measure of moisture in oil and describes the ratio between the actual amount of dissolved water in the oil and the maximum amount possible at a given temperature. An a_w value of 0 means that there is no water in the oil, while an a_w value of 1 indicates complete saturation. Water activity is independent of the type of oil.
- The absolute moisture content is called water content (x) and expresses the actual amount of water in the oil, whether it is dissolved, emulsified or separated. Water content is measured in units such as ppm (parts per million) or mg of water per kg of oil and is independent of oil temperature. To assess the degree of saturation of the oil, the water content x must be considered in conjunction with the temperature (T).

The calculation of the water content x from the measured values for a_w and T is oil-specific and requires special parameters for the respective oil. CS INSTRUMENTS offers the possibility to adapt these oil specific parameters for different oil types.

The required parameters can either be specified when ordering the FO 510 or subsequently integrated in the FO 510 using the CS Service software.

Advantages of the FO 510:

- Fast response time
- Highly accurate measurement of water activity (aw), as well as process temperature. Measurement is independent of oil type or age.
- Calculation of absolute water content (PPM) possible after input of specific oil parameters
- Two freely configurable analog outputs as well as Modbus-RTU (RS 485) interface available).

Programming by software.

With the CS Service Software incl. USB / Modbus adapter settings like Modbus settings can be changed, analog output can be rescaled and measured values can be assigned. Ability to adapt these oil specific parameters for different oil types.

5 Technical data

Measuring range humidity	-0..1 a _w
Accuracy (0..0,9 a _w)	±0.02 Accuracy (0..0,9 a _w) bei 23°C
Accuracy (0,9..1,0 a _w)	typically ± 0.03 a _w at 23°C
Measuring range temperature:	0.. 100°C
Accuracy :	±0.3°C
Perm. oil temperature:	-20..100°C
Perm. ambient temperature:	-20 ..70°C
Storage temperature :	-40...80 °C
Pressure range :	up to 300 bar
Power supply :	24VDC (10...30 VDC)
Output :	2x 4..20 mA (3wire-Technology) RS 485 (Modbus RTU)
Protection class:	IP 66
Load for analogue output::	< 500 Ohm
Screw in thread:	G 1/2" Optional: NPT ½"
Material case :	Zinc die casting
Wetted parts:	Sensor protection Perforated cap 1.4301 (SS304) Process connection (screw-in thread) 1.4404 (SS 316L)
Electr. connection:	M12, 8-pin, A-Coding
EMC:	DIN EN 61326-1

6 Dimension / elektr. Connection



Dimension

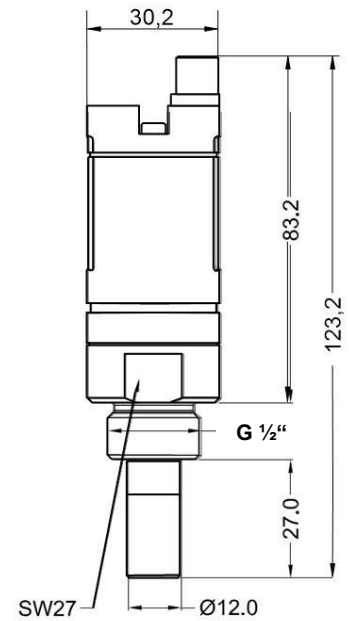

Pin 1	Pin 2	Pin 3	Pin 4	Pin 5	Pin 6	Pin 7	Pin 8
NC	RS485 (B)	RS485 (A)	+I output	+I output	-VB	NC	+VB

+VB	Positive supply voltage 24VDC (10...30 VDC) smoothed
RS485 (A)	Modbus A (+)
-VB	Negative supply voltage
RS 485 (B)	Modbus B (-)
+I	Positive 4...20 mA Signal **
NC	not connected

** Measuring value assignment for 4-20mA signal selectable

M12 Connector

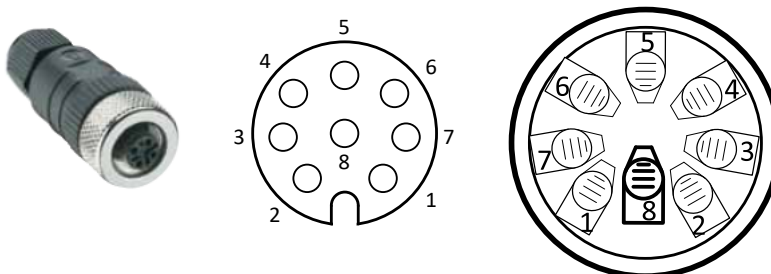

Connection diagram

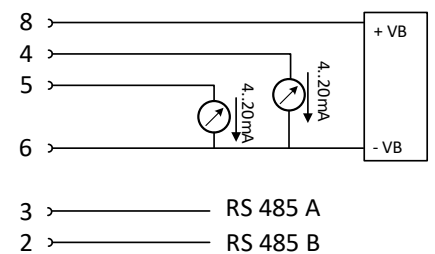

Remark: The sensor must be connected in stainless state only

7 Installationshinweise



- The direct installation of the sensor is only allowed in the unpressurized state of the system.
- The sensor must be tightened with a torque of 25 - 30 Nm.
- Tightness of the connection must be checked and ensured.
- It is not permitted to use a sealing ring with a NPT 1/2" Instead, use a suitable PTFE sealing tape or sealant.



Screw the sensor with the G 1/2" thread pressure-tight into the line to be measured via a connecting piece.

Place the sensor tip (hole cap) as deep as possible in the oil (> 40% of the sensor tip length).

To obtain the shortest possible response time, there should be a continuous flow of oil.

8 Modbus

The dew point sensor FO 510 comes with a Modbus RTU Interface.
Before commissioning of the sensor the communication parameters

Modbus ID, Baudrate, Parity und Stop bit

must be set in order to ensure the communication with the Modbus master.
The adjustment can be done either with the CS Instruments PC service software.

Modbus communication default values:

- Modbus ID : 1 (1 -247)
- Baudrate: 19200 bps (1200,2400, 4800, 9600, 19200, 38400 bps)
- Parity: even (none, even, odd)
- Stoppbit: 1 1,2)

Supported are following functioncodes:

- Funktionscode 03: Read Holding Register
- Funktionscode 16: Write multiple Register

8.1 Register Mapping measuring values:

Modbus Register	Modbus Adresse	No.of Byte	Data Type	Description	Default Setting	Read Write	Unit /Comment
1001	1000	4	Float	Temperature		R	[°C]
1003	1002	4	Float	Temperature		R	[°F]
1005	1004	4	Float	Water Activity aw		R	
1007	1006	4	Float	xs PPM		R	
1009	1008	4	Float	xs PPM static temperature		R	
1011	1010	4	Float	relative Humidity		R	

for DS400 / DS 500 / Handheld devices - Modbus Sensor Datatyp:

„Data Type R4-32“ match with „Data Type Float“

8.2 Registermapping device settings

Modbus Settings (2001...2006)

Modbus Register	Modbus Address	No.of Byte	Data Type	Description	Default Setting	Read Write	Unit /Comment
2001	2000	2	UInt16	Modbus ID	1	R/W	Modbus ID 1...247
2002	2001	2	UInt16	Baudrate	4	R/W	0 = 1200 1 = 2400 2 = 4800 3 = 9600 4 = 19200 5 = 38400
2003	2002	2	UInt16	Parity	1	R/W	0 = none 1 = even 2 = odd
2004	2003	2	UInt16	Number of Stopbits		R/W	0 = 1 Stop Bit 1 = 2 Stop Bit
2005	2004	2	UInt16	Word Order	0xABCD	R/W	0xABCD = Big Endian 0xCDAB = Middle Endian
2006	2005	2	UInt16	Modbus Enabled	FA510: 1 FA515: 0	R/W	0 = Modbus disabled 1 = Modbus Enabled

8.3 Analog Scaling Settings (2007...2011)

Modbus Register	Modbus Address	No.of Byte	Data Type	Description	Default Setting	Read Write	Unit /Comment
2007	2006	4	UInt32	Output Value	4	R/W	0 = 4-20mA disabled 1 = Temperature [°C] 2 = Temperature [°F] 3 = relative Humidity [%] 4 = DewPoint [°C] 5 = DewPoint [°F] 6 = Absolute Humidity [g/m3] 7 = Absolute Humidity [mg/m3] 8 = Humidity Grade [g/kg] 9 = Vapor Ratio [ppm] 10 = SaturationVapor Pressure[hPa] 11 = Partial Vapor Pressure [hPa] 12 = Atmospheric DewPoint [°C] 13 = Atmospheric DewPoint [°F]
2009	2008	4	float	4mA Scale Low	-80	R/W	
2011	2010	4	float	20mA Scale High	20	R/W	

Modbus installation, Modbus settings and further information refer to the manual CS Instruments "**Modbus Installation and Operating Instructions FA 5xx sensors**"

9 Calibration / Adjustment

At the manufacturer

Within the scope of DIN ISO certification, we recommend having the measuring instruments calibrated and, if necessary, adjusted by the manufacturer at regular intervals. The calibration cycles should be based on your internal specifications. Within the scope of DIN ISO certification, we recommend a calibration cycle of one year for the FO 510.

10 Warranty

Defects which are demonstrably due to a factory defect will of course be repaired free of charge. The prerequisite is that you report this defect immediately upon discovery and within the warranty period granted by us. Damage caused by improper use or by non-observance of the operating instructions is excluded from this warranty.

The warranty is also void if the sensor has been opened - unless this is expressly described in the operating instructions for maintenance purposes - or if serial numbers in the device have been changed, damaged or removed..

The warranty period for FO 510 is 12 months. Unless otherwise defined, 6 months apply to accessories. Warranty services do not cause an extension of the warranty period.

If in addition to the warranty service necessary repairs, adjustments or similar are carried out, the warranty services are free of charge but there is a charge for other services such as transport and packing costs. Other claims, especially those for damage occurring outside the instrument are not included unless responsibility is legally binding.

After-sales service after the warranty time has elapsed

Of course, we are also there for you after the warranty period has expired. In case of malfunctions, please send us your measuring device with a short description of the error. Please also include your telephone number for any queries.

KONFORMITÄTSERKLÄRUNG

DECLARATION OF CONFORMITY

Wir
We

CS Instruments GmbH & Co.KG
Gewerbehof 14, 24955 Harrislee

Erklären in alleiniger Verantwortung, dass das Produkt

Declare under our sole responsibility that the product

Feuchtesensoren FO 510

Dew point sensors FO 510

den Anforderungen folgender Richtlinien entsprechen:

We hereby declare that above mentioned components comply with requirements of the following EU directives:

Elektromagnetische Verträglichkeit Electromagnetic compatibility	2014/30/EUG 2014/30/EC
RoHS (Restriction of certain Hazardous Substances)	2011/65/EC

Angewandte harmonisierte Normen:

Harmonised standards applied:

EMV-Anforderungen EMC requirements	EN 55011: 2011-04 EN 61326-1: 2013-07
--	--

Das Produkt ist mit dem abgebildeten Zeichen gekennzeichnet.
The product is labelled with the indicated mark.



Harrislee, den 15.09.2023

Wolfgang Blessing Geschäftsführer

