



Quick Start Guide

 All software & files can be downloaded from
<https://www.milesight.com/iot/resources/download-center/#documents>

Better Inside, More in Sight

Milesight IoT Co., Ltd. | www.milesight.com



QUICK START GUIDE

Ultra Low Power Solar Gateway 



SG50

Content

1. Packing List.....	2
2. Hardware Introduction.....	3
3. SIM Card Installation.....	4
4. Power Supply.....	4
5. Installation.....	6
6. Web GUI Access.....	11
7. FCC Statement.....	12

1. Packing List



1 x SG50 Device



1 x Battery Pack



1 x SIM Card Ejector Tool



1 x LoRaWAN® Antenna



1 x Antenna Coaxial Cable (1m)



1 x Antenna U-strap Kit



1 x Antenna U-bolt Kit

1 x Solar Panel
(With M12 Power Cable)

4 x Mounting Screws

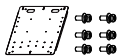

1 x Solar Panel Bracket Kit

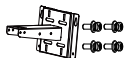

1 x Mounting Bracket Kit



2 x Hose Clamps



4 x Wall Mount Screw Kits



1 x Quick Start Guide



1 x Warranty Card

2. Hardware Introduction

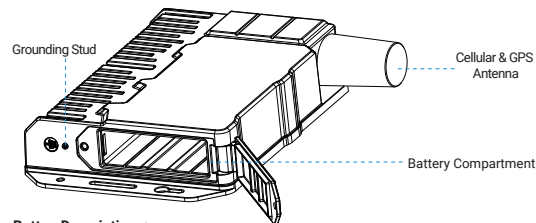
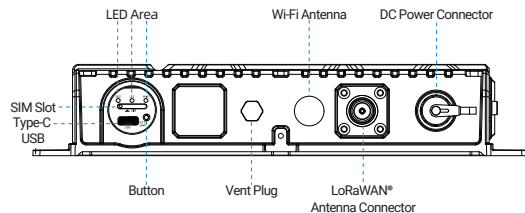

Button Descriptions:

Function	Action	LED Indicator
Turn On/Off Wi-Fi	Quick press the button once.	Wi-Fi off: Wi-Fi LED off Wi-Fi on: Wi-Fi LED static on.
Reset to Factory Default	Press and hold the button for more than 5 seconds.	SYS LED quickly blinks.

3. SIM Card Installation

1. Take the SIM cover down, use an ejector tool to open the SIM card tray. Insert the nano SIM card, then put the slot with the SIM card back into the device.
2. Rotate back the cover and tighten it with a wrench to prevent water from entering the device.

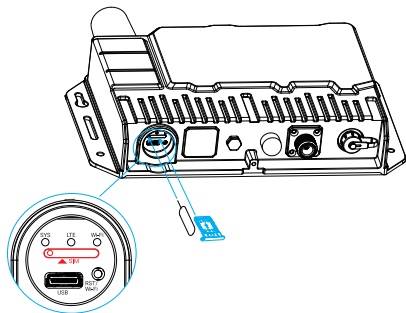

4. Power Supply

SG50 can be powered by either a 12-24 VDC external supply or solar panel. In the meantime, the internal battery pack will also be charged. When the external supply is disconnected or there is not enough power for the solar panel, SG50 can be powered by the internal battery pack.

Battery Installation

1. Release the fixing screw on the side of the device, and remove the battery compartment cover.
2. Push the battery into the battery compartment as the icon shows.
3. Fix the cover back to the device using the fixing screw.

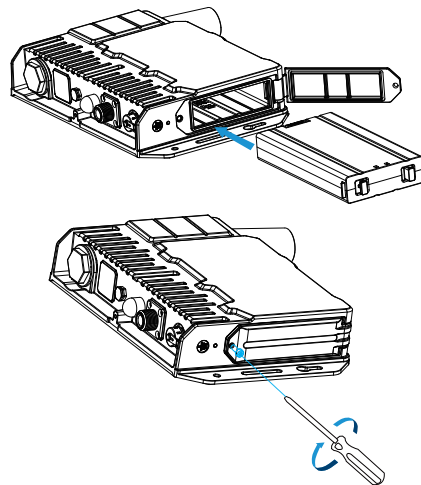

Note:

- After installing the battery, the device will not power on automatically. Please connect the power cable of the solar panel to the device to turn it on. When the power cable is disconnected, the device will power off.
- The device can not be charged when its temperature is more than 50°C. Please avoid direct exposure of the device to sunlight.
- The battery should be removed from the device if it will not be used for an extended period.
- Hold the latches on the battery pack to pull it out.



5. Installation

Bracket Wall Mounting

Drill 4 holes on the wall according to the mounting bracket and insert the wall plugs into these holes. Then fix the mounting bracket to the wall by fixing the wall mounting screws into the wall plugs.

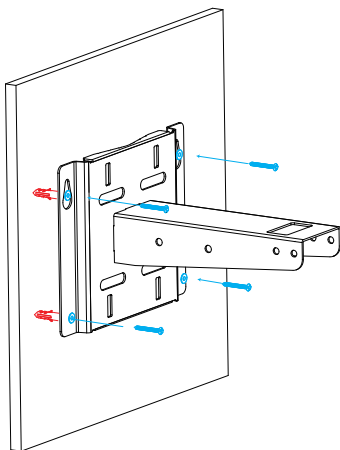

Bracket Pole Mounting

Straighten the hose clamps and slide them through the rectangular rings in the mounting bracket. Wrap the hose clamps around the pole, then use a screwdriver to tighten the locking mechanism by turning it clockwise.

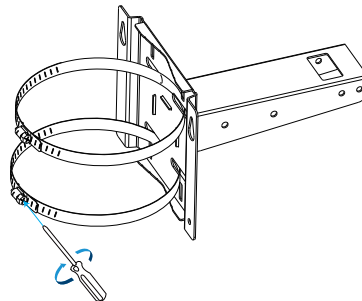

Solar Panel Installation

1. Fix the solar panel to the solar panel bracket using 6 fixing screws.

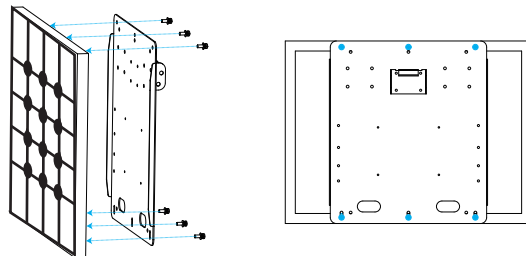

2. Hang the solar panel bracket onto the mounting bracket and fix both parts using 2 fixing screws first. Adjust the angle of the solar panel bracket (15°, 45°, and 75° is optional) based on the installation environment. Then fix the remaining two screws to the solar panel bracket.

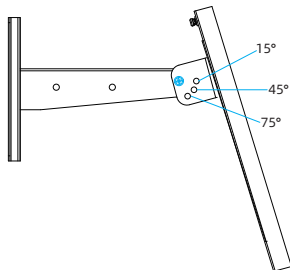

Device Installation

1. Fix the device to the opposite side of the solar panel bracket using 4 screws. When installation, it is suggested to fix the 2 screws on the top at first.
2. Install antennas as subsequent steps.

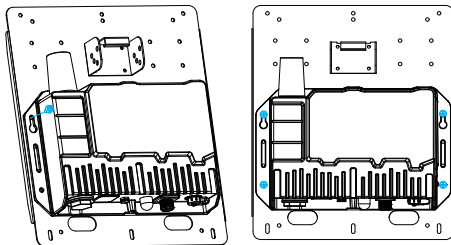

3. Connect M12 power cable of solar panel to DC power connector of device, the device will power on automatically.

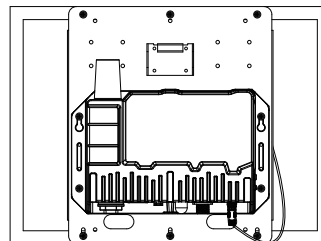

Antenna U-strap Installation

1. Pass the LoRaWAN® antenna through the U-strap clamp and fix the U-strap clamp to the side of the mounting bracket using 2 flat washers and 2 screws.

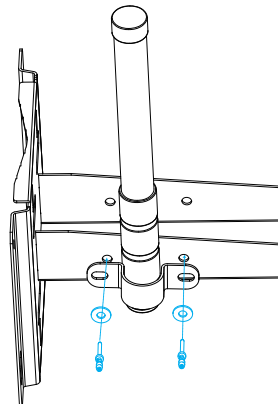

2. Connect one end of the antenna coaxial cable to the LoRaWAN® antenna, the opposite end to the device's antenna connector.

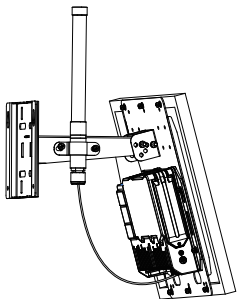

Antenna U-bolt Installation

1. Pass the LoRaWAN® antenna through the antenna clamp and fix it using 4 screws, then wrap the U-bolt around the pole and fix the clamp with nuts and other accessories.

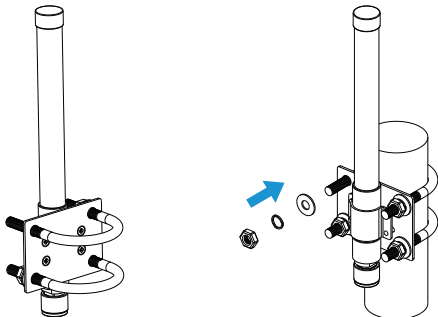

2. Connect one end of the antenna coaxial cable to the LoRaWAN® antenna, and the opposite end to the device's antenna connector.

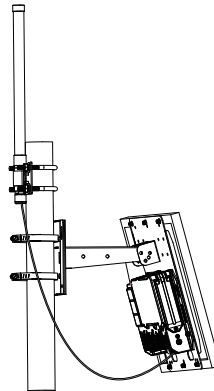

6. Web GUI Access

SG50 provides a web-based configuration interface for management. If it is the first time you configure the device, please use the default settings listed below:

Wi-Fi SSID: **Gateway_XXXXXX**

Wi-Fi IP Address: **192.168.23.1**

Username: **admin**

Password: **password**

Configuration Steps:

1. Ensure the Wi-Fi LED is statically on.
2. Enable Wireless Network Connection on your computer and search for the SSID to connect it.
3. Type 192.168.23.1 to the browser to log in the web GUI of device.

7. FCC Statement

Any changes or modifications not expressly approved by the party responsible for compliance could void the user's authority to operate the equipment.

This device complies with part 15 of the FCC Rules. Operation is subject to the following two conditions:

- (1) This device may not cause harmful interference, and.
- (2) This device must accept any interference received, including interference that may cause undesired operation.

Note: This equipment has been tested and found to comply with the limits for a Class B digital device, pursuant to part 15 of the FCC Rules. These limits are designed to provide reasonable protection against harmful interference in a residential installation. This equipment generates, uses and can radiate radio frequency energy and, if not installed and used in accordance with the instructions, may cause harmful interference to radio communications.

However, there is no guarantee that interference will not occur in a particular installation. If this equipment does cause harmful interference to radio or television reception, which can be determined by turning the equipment off and on, the user is encouraged to try to correct the interference by one or more of the following measures:

- Reorient or relocate the receiving antenna.
- Increase the separation between the equipment and receiver.
- Connect the equipment into an outlet on a circuit different from that to which the receiver is connected.
- Consult the dealer or an experienced radio/TV technician for help.

FCC Radiation Exposure Statement:

This equipment complies with FCC radiation exposure limits set forth for an uncontrolled environment. This equipment should be installed and operated with minimum distance 20cm between the radiator& your body. This transmitter must not be co-located or operating in conjunction with any other antenna or transmitter.

OneTemp[®]
measure | control | record

1300 768 887
www.onetemp.com.au