

JUMO DELOS S02

Pressure transmitter with display

Areas of application

- Food and pharmaceutical industry
- CIP and SIP plants
- Air conditioning and refrigeration applications
- Mechanical and plant engineering

Special features

- Compact design
- High degree of accuracy
- Rotating top section of the housing
- Configuration via JUMO smartCONNECT app
- Connection to JUMO Cloud

Description

The pressure transmitter with display measures the absolute or relative pressure of liquid, vaporous, and gaseous media.

The device is suitable for mounting in pipes and containers in various applications. It is mounted using individual process connections.

Measurands

- Pressure

Interfaces

- Bluetooth
- IO-Link
- Single Pair Ethernet (SPE)



Type 405056/...



Technical data

Electrical safety

Requirements	DIN EN 61010-1:2020 The device must be equipped with an electrical circuit that meets the requirements for "Limited-energy circuits".
--------------	--

Electrical data

Device with IO-Link

Voltage supply	DC 18 to 30 V SELV, PELV, Class 2
Current consumption	
IO-Link operation	≤ 100 mA
Operation with switching output	≤ 600 mA
Power consumption	
IO-Link operation	≤ 1.8 W
Operation with switching output	≤ 18 W
Protection rating	DIN EN 61140, Class III (protective low voltage)
Electrical connection	
Connection elements	
Device	M12 plug connector
Connecting cable	M12 plug connector
M12 plug connector	IEC 61076-2-101
Version	4-pole
Connecting cable	
Conductor cross section	
IO-Link operation	≥ AWG 22
Operation with switching output	≥ AWG 21
Version	4-core, copper
Line length	≤ 20 m
Temperature resistance	≥ 80 °C
For UL application	
Approved cables ^a	CYJV2/8, CYJV/7, PVVA2/8, PVVA/7

^a The cables must be suitable for the voltage and current used.

Device with SPE

Voltage supply	DC 18 to 30 V, PELV
Current consumption	≤ 100 mA
Power consumption	≤ 1.8 W
Overvoltage category	II
Pollution degree	2
Protection rating	DIN EN 61140, Class III (protective low voltage)
PoDL class	Class 11, IEEE 802.3cg
PoDL classification	SCCP or Forced Mode
Electrical connection	
Connection element	M12 plug connection
M12 plug connector	IEC 63171-5
Version	2-pole
Connecting cable	IEC 61156-13, IEC 61156-14
Version	2-core, shielded
Bandwidth	≥ 20 MHz
Line length	≤ 500 m (\geq AWG 22 at \geq DC 24 V supply voltage into the cable)
DC loop resistance	< 59 Ω
Temperature resistance	≥ 80 °C

Inputs

Measurands

Reference conditions

Basic principles	EN 61298-1, DIN 16086, DIN EN 60770
Installation position	Any
Calibration position	Device upright, process connection at the bottom

Relative pressure

Measuring range bar	Linearity ^a % MSP ^e	Accuracy with		Long-term stability % MSP per year	Overload capability ^b bar	Burst pressure bar
		20 °C ^c % MSP	-20 to +75 °C ^d % MSP			
0 to 0.4	0.15	0.40	1.00	≤ 0.15	10	20
0 to 1	0.15	0.30	1.00	≤ 0.15	10	20
0 to 4	0.10	0.25	0.75	≤ 0.10	25	50
0 to 10	0.10	0.25	0.75	≤ 0.10	50	60
0 to 25	0.10	0.25	0.75	≤ 0.10	120	200
0 to 60	0.10	0.25	0.75	≤ 0.10	300	400
0 to 100	0.10	0.25	0.75	≤ 0.10	300	400
-0.1 to +0.1	0.20	0.50	1.00	≤ 0.20	6	10
-0.4 to +0.4	0.15	0.40	1.00	≤ 0.20	10	20
-1 to +1	0.15	0.30	1.00	≤ 0.15	10	20
-1 to +3	0.10	0.25	0.75	≤ 0.10	25	50
-1 to +9	0.10	0.25	0.75	≤ 0.10	50	60
-1 to +24	0.10	0.25	0.75	≤ 0.10	120	200

^a According to limit point setting.

^b All pressure transmitters are vacuum proof.

^c Includes: linearity, hysteresis, repeatability, deviation of measuring range start value and measuring range end value.

^d Includes: linearity, hysteresis, repeatability, deviation of measuring range start value and measuring range end value, thermal effect on measuring range start and measuring span.

^e MSP = measuring span.

Absolute pressure

Measuring range bar	Linearity ^a % MSP ^e	Accuracy with		Long-term stability % MSP per year	Overload capability ^b bar	Burst pressure bar
		20 °C ^c % MSP	-20 to +75 °C ^d % MSP			
0 to 0.4	0.15	0.40	1.00	≤ 0.15	10	20
0 to 1	0.15	0.30	1.00	≤ 0.15	10	20
0 to 4	0.10	0.25	0.75	≤ 0.10	25	50
0 to 10	0.10	0.25	0.75	≤ 0.10	50	60
0 to 25	0.10	0.25	0.75	≤ 0.10	120	200
0 to 60	0.10	0.25	0.75	≤ 0.10	200	300

^a According to limit point setting.

^b All pressure transmitters are vacuum proof.

^c Includes: linearity, hysteresis, repeatability, deviation of measuring range start value and measuring range end value.

^d Includes: linearity, hysteresis, repeatability, deviation of measuring range start value and measuring range end value, thermal effect on measuring range start and measuring span.

^e MSP = measuring span.

Outputs

Analog outputs

Device with IO-Link

Current output	
Function	Output of the process value, output of a signal for error messaging
Signal range	4.0 to 20 mA
Signal limits	3.4 to 22 mA
Accuracy	±0.1 % of 16 mA
Temperature influence	75 ppm/K
Burden	≤ 500 Ω
Burden influence	±0.02 % per 100 Ω
Voltage output	
Function	Output of the process value, output of a signal for error messaging
Signal range	DC 0 to 10 V
Signal limits	DC 0 to 11 V
Accuracy	±0.1 % of 10 V
Temperature influence	75 ppm/K
Load	≥ 2000 Ω
Load influence	≤ 15 mV

Digital outputs

Device with IO-Link

Type	Switching output
Protection	Against short circuiting and overload, protected against polarity reversal
Output signal	Push-pull, PNP, NPN
Ampacity	≤ 200 mA
Voltage drop	≤ 3.5 V
Switching output	
Function	Limit value monitoring function
Input signal	Pressure
Output signal	2 limit value switches, device error
Switch-on and switch-off delay	0 to 100 s
Limit value function	Hysteresis mode, window mode, two-point mode
Switching points	Configurable

Interfaces

Bluetooth

Function	Transfer of configuration data and device information, display of process values
Communication	Via end device with JUMO smartCONNECT app
Authentication	Via Bluetooth® radio module and NFC tag
Connection status (configurable)	
Permanently	Active
Temporarily	Restricted (via NFC)
Range	10 m under reference conditions
Radio frequency	
Bluetooth® radio module	2.4 GHz
NFC tag	13.56 MHz
Max. transmission power	
Bluetooth® radio module	0 dBm
NFC tag	–
JUMO smartCONNECT app	
System requirements	
iOS device	iPhone 7 or later (recommended) with iOS 13
Android device	Android 8.0 or later

IO-Link

Function	Transfer of process data, configuration data and device information, displaying of process values
Communication	Via end device with IO-Link master and device description file (IODD)
Communication interface	IO-Link device V 1.1
Data transfer rate (baud rate)	COM 3 (230.4 kBaud)
Cycle time	≥ 5 ms
Profile	Common Profile, Smart Sensor Profile

SPE

Function	Transfer of process data, configuration data, and device information, voltage supply via PoDL
Communication	Via end device and JUMO Cloud, via Modbus master
SPE standard	10BASE-T1L
Transmission protocol	Integrated JUMO Cloud gateway, Modbus TCP
Data transfer rate	10 Mbit/s

Display

Type	LCD
Display range	22.5 × 26.0 mm
Resolution	
Process value display	18-segment
Text line	5 × 8 Dot-Matrix
Brightness	11 levels (configurable)
Alignment	0°, 180°

Environmental influences

Admissible ambient temperature	DIN 60068-2-1, DIN 60068-2-2 -25 to +75 °C
Admissible medium temperature	-25 to +100 °C (135 °C maximum 1 hour per day not in use)
Admissible storage temperature	-40 to +85 °C
Climatic conditions	DIN EN 60721-3-3
Climate class	3K6
Air temperature	-25 to +55 °C
Relative humidity	
Storage	≤ 90 %
Operation	≤ 100 % – condensation on device outer shell
Protection type	DIN EN 60529 IP65, IP67
Electromagnetic compatibility (EMC)	DIN EN 61326-2-3:2022
Interference emission	Class B ^a
Interference immunity	Industrial requirements
Oscillation	DIN EN 60068-2-6
Amplitude	1.5 mm at 10 to 2000 Hz
Acceleration	200 m/s ² at 10 to 2000 Hz
Shock	DIN EN 60068-2-27 500 m/s ² for 11 ms, 1000 m/s ² for 1 ms
Site altitude	≤ 2000 m above sea level

^a The product is suitable for industrial use as well as for households and small businesses.

Mechanical features

Device

Weight Process connection G 1/4	~ 155 g
Alignment Top section of the housing	Can be rotated by 330°

Sensor

Measuring principle	Piezoresistive (absolute pressure sensor, relative pressure sensor)
Admissible load changes	> 10 million

Process connections

Specifications according to DIN standard. Temperature range depends on pressure range and sealing material.

Front-flush

Designation	Max. pressure	Temperature range
G 3/4 front-flush DIN EN ISO 228-1	25 bar	-10 to +150 °C
	40 bar	-10 to +100 °C
G 1/2 front-flush with double seal	25 bar	-10 to +150 °C
	40 bar	-10 to +100 °C
G 3/4 front-flush with double seal	25 bar	-10 to +150 °C
	40 bar	-10 to +100 °C
G 1 front-flush with double seal	40 bar	-10 to +100 °C
Taper socket with grooved union nut DN 25 DIN 11851	40 bar	-10 to +140 °C
Taper socket with grooved union nut DN 40 DIN 11851	40 bar	-10 to +140 °C
Clamping socket (clamp) DN 10/15/20 DIN 32676	25 bar	-10 to +140 °C
Tank connection with grooved union nut DN 25 round thread 52 × 1/6 (dairy pipe fitting)	25 bar	Up to 150 °C
	40 bar	Up to 100 °C

Front-flush, with EHEDG certification

Designation	Max. pressure	Temperature range
Clamping socket (clamp) DN 25/32/40 DIN 32676	25 bar	-10 to +140 °C
Clamping socket (clamp) DN 50 DIN 32676, 2" ISO 2852	16 bar	-10 to +140 °C
JUMO PEKA Hygienic process connection	25 bar	-10 to +200 °C
	40 bar	-10 to +100 °C

Materials

Housing	
Top section of the housing	PBT-GF30
Case bottom section	1.4301 (304), PBT-GF30
Threaded sleeve M12 x 1	1.4301 (304)
Seal	EPDM
Display	PMMA
Process connection	
Without EHEDG certification	1.4571 (316Ti)
With EHEDG certification	1.4404 (316L)
Sensor	Silicon
Membrane	1.4435 (316L)
Filling oil	Silicone oil, FDA-compliant oil
Welding ring	1.4404 (316L)
O-ring, sealing ring	FPM, others available as an optional extra (e.g. EPDM, VMQ)

Dimensions

Device

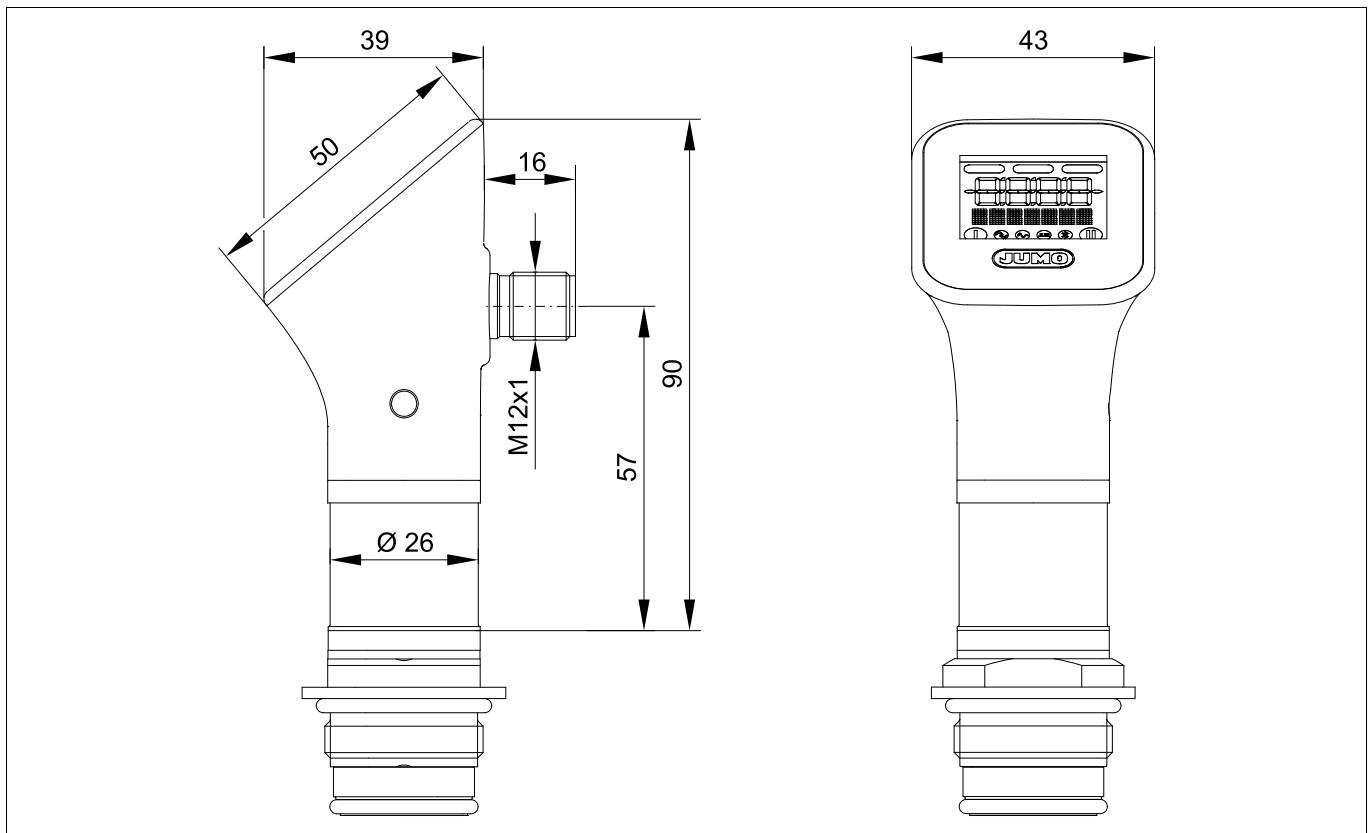

Process connections

Not front-flush

G 1/2 DIN EN 837

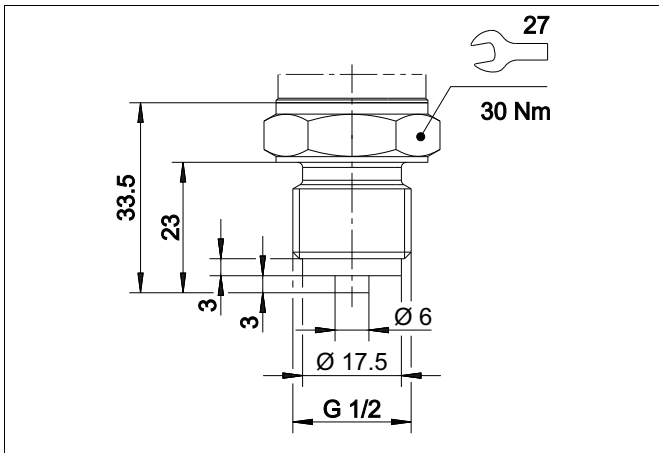

1/4" – 18 NPT DIN EN 837

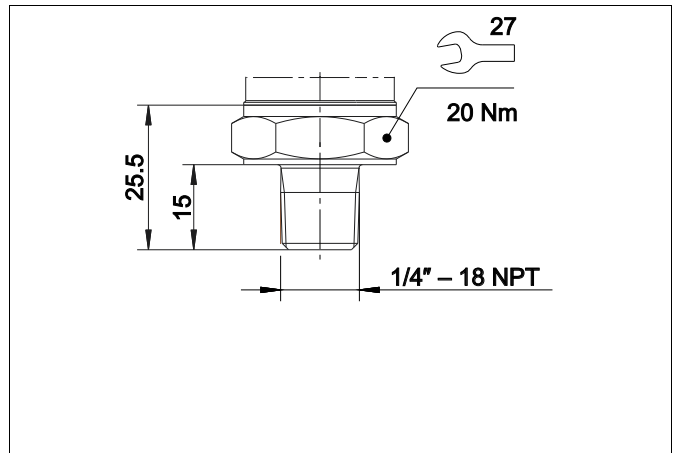

G 1/4 DIN EN 3852-11

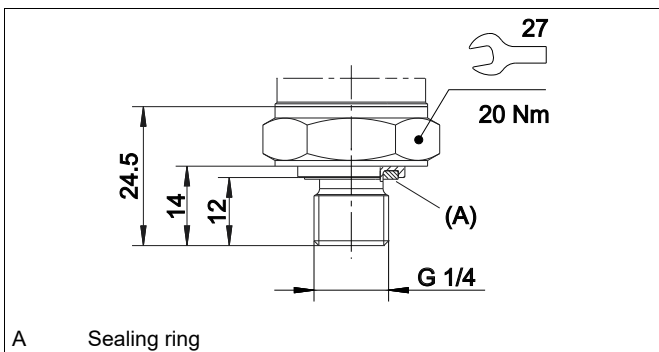

G 1/2 DIN EN 3852-11

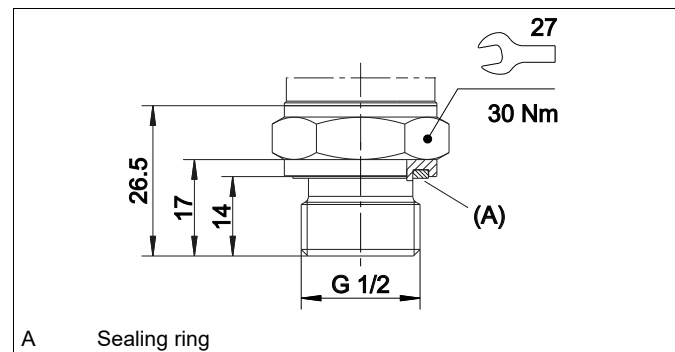

Front-flush

G 3/4 front-flush DIN EN ISO 228-1

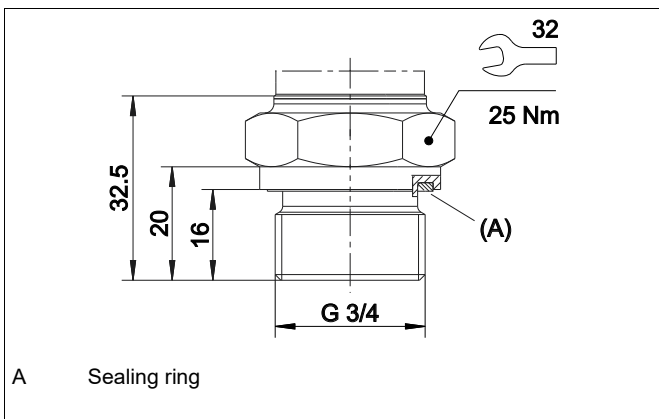

G 1/2 front-flush with double seal

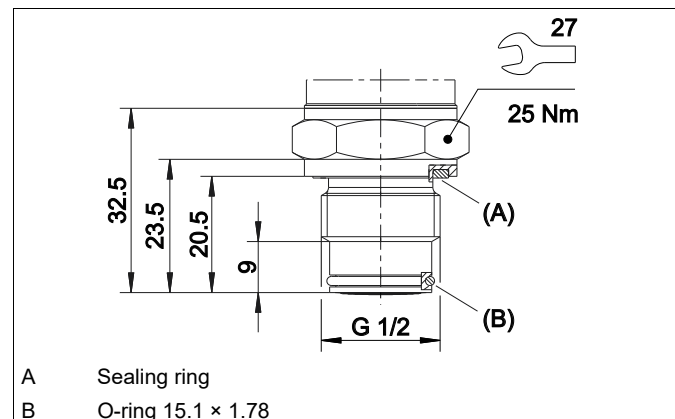

G 3/4 front-flush with double seal

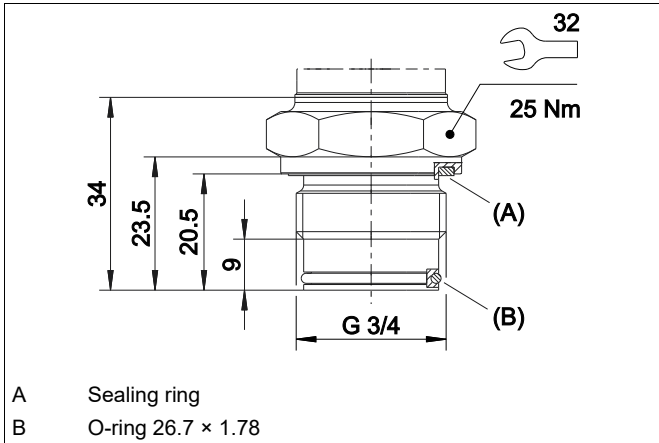

G 1 front-flush with double seal

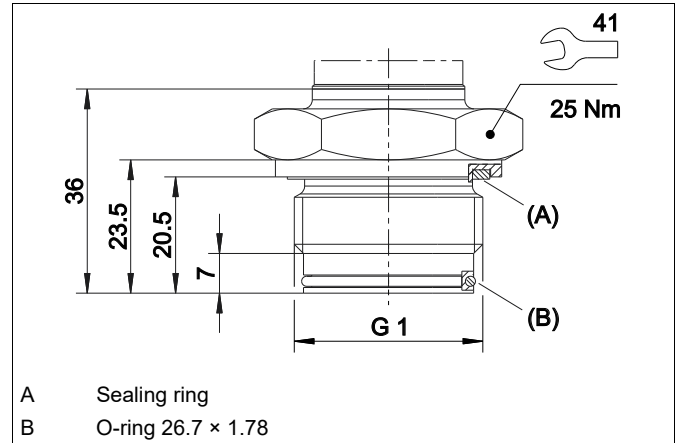

Taper socket with grooved union nut, DN 25
DIN 11851

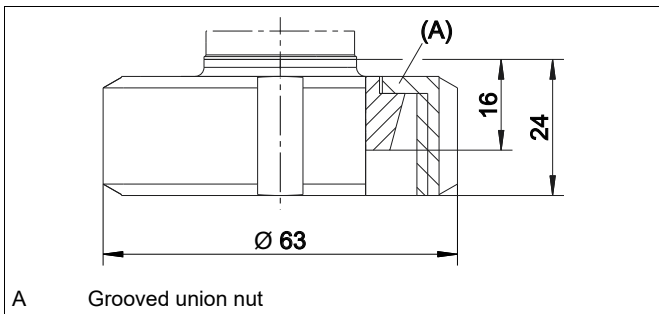

Taper socket with grooved union nut, DN 40
DIN 11851

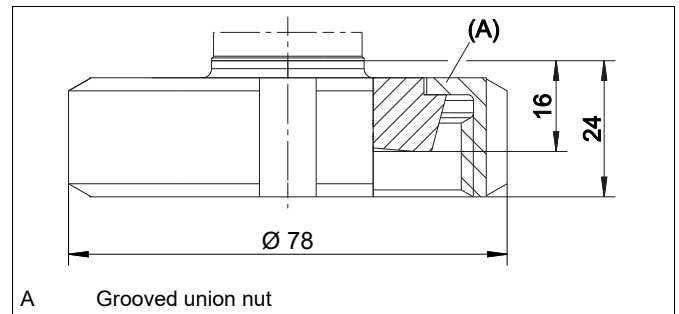

Clamping socket (clamp) DN 10/15/20
DIN 32676

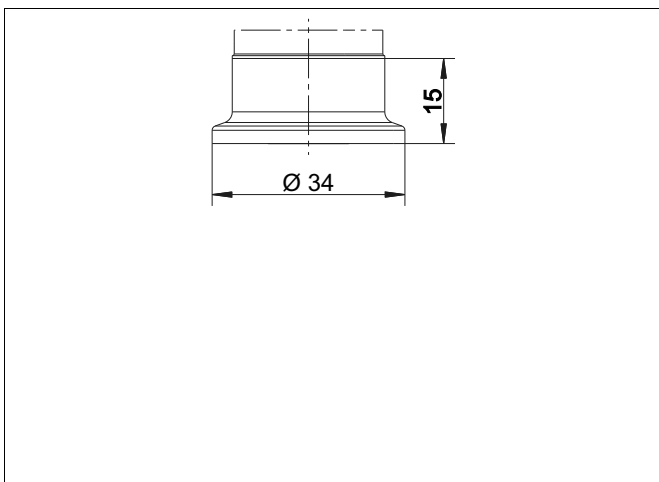

Tank connection with grooved union nut, DN 25
Round thread 52 × 1/6 (dairy pipe fitting)

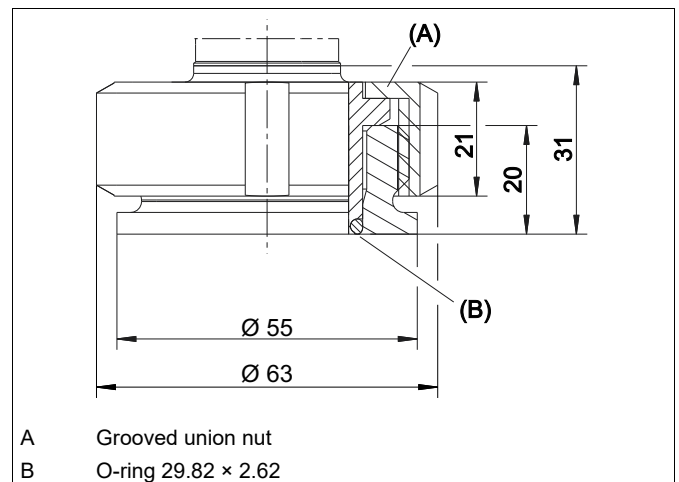

Front-flush, with EHEDG certification

Clamping socket (clamp) DN 25/32/40
DIN 32676

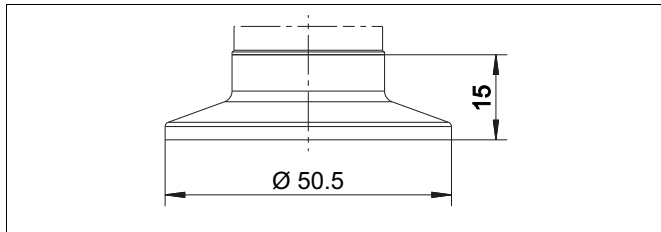

Clamping socket (clamp) DN 50
DIN 32676, 2" ISO 2852

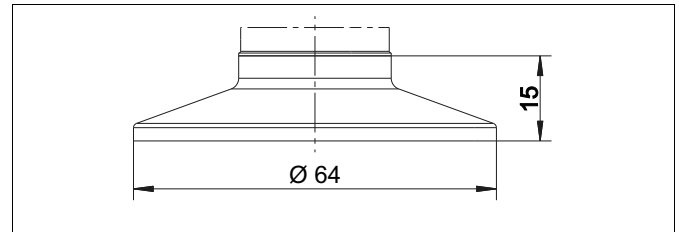

JUMO PEKA

Hygienic process connection

⇒ [Data sheet 409711](#)

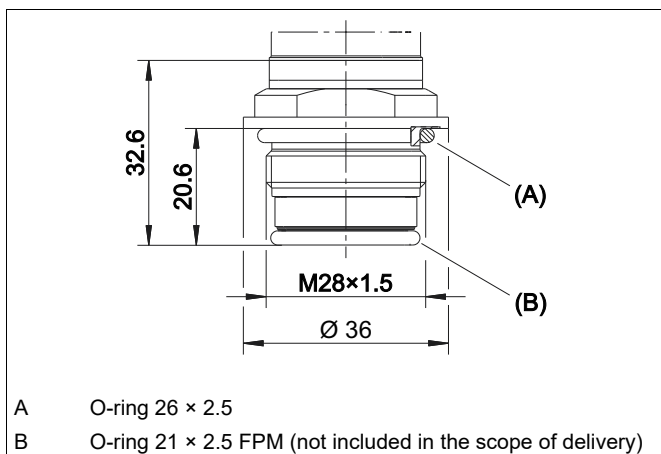

Display elements

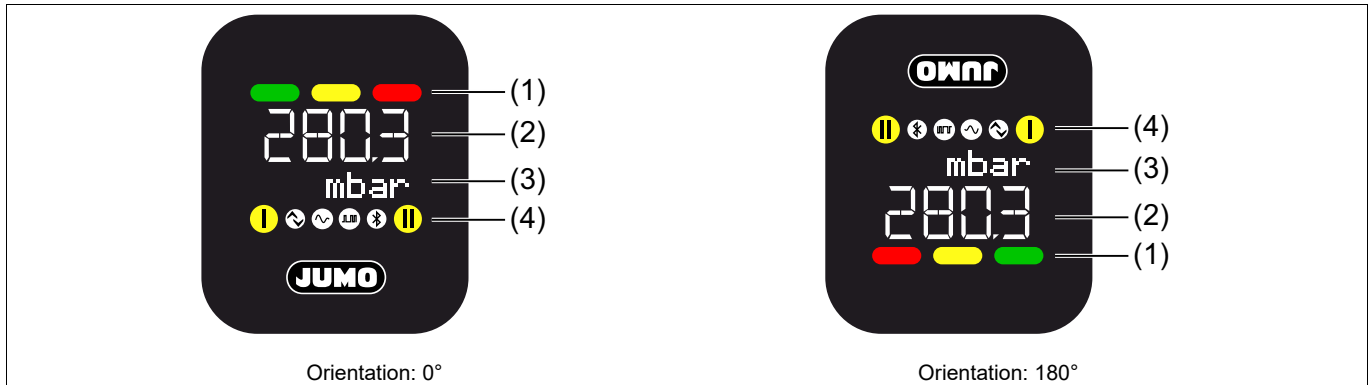

Pos.	Designation	Description
1	Device status Multicolored	Indicates the device status based on the classification according to NAMUR NE 107: <ul style="list-style-type: none"> Steady green = Normal operation Flashing green = Maintenance required Steady yellow^a = Outside the specification (S) Steady red = Failure (F) Flashing red = Functional check (C)
2	Process value	Shows: <ul style="list-style-type: none"> The measured process value Error messages
3	Text line	Shows: <ul style="list-style-type: none"> The configured unit Error messages and warnings as running text
4	Toolbar	Shows: <ul style="list-style-type: none"> The configuration and status of I/O Pin 1 and I/O Pin 2 The configuration and status of the interface connections

^a Contrary to classification according to NAMUR NE 107, steady yellow instead of flashing red.

Connection elements

The connection elements in the data sheet provide information on product selection.

For the electrical connection, only use the installation instructions or the operating manual.

Device with IO-Link

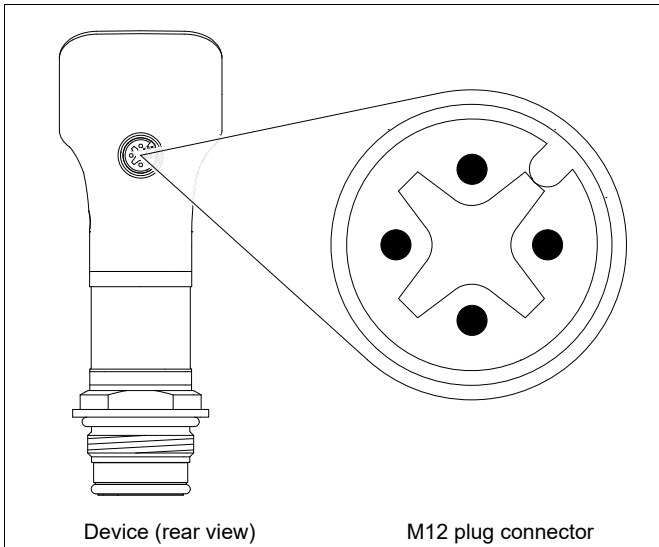

Device with SPE

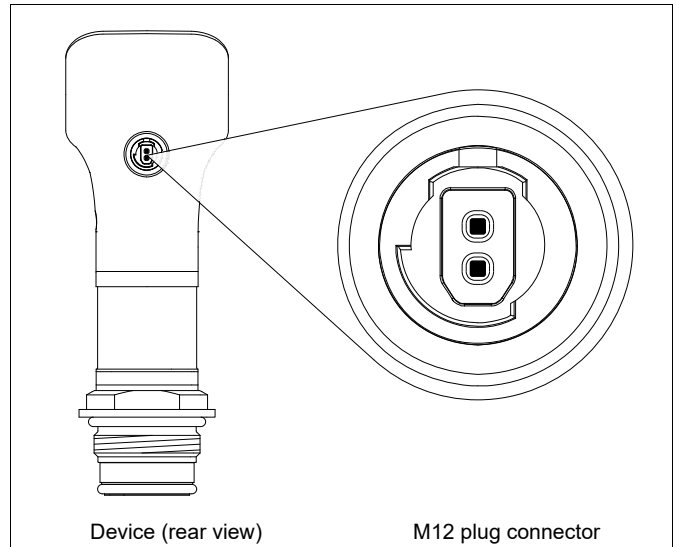

Terminal assignment

M12 plug connection

Designation	Description	Assignment
IO-Link	DC 24 V	1 BN (brown)
	I/O Pin 2 (DI/DQ) ^a	2 WH (white)
	GND	3 BU (blue)
	I/O Pin 1 (C/Q) ^b	4 BK (black)

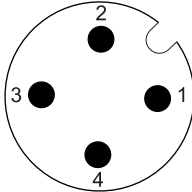
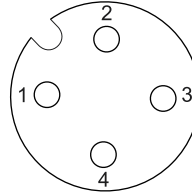
^a Configurable as: inactive, digital output, analog output.

^b Configurable as: inactive, IO-Link, digital output.

Designation	Description	Assignment
SPE	RxTx+/PoDL+	1 WH (white)
	RxTx-/PoDL-	2 BU (blue)

Order details

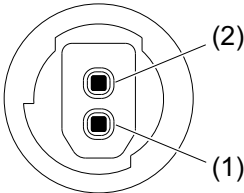
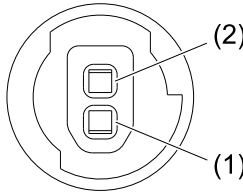
	(1) Basic type
405056	JUMO DELOS S02 – pressure transmitter
	(2) Version
0	Standard
2	Customer-specifically modified software
	(3) Housing
7	Stainless steel and plastic
	(4) Input
427	-0.1 to +0.1 bar relative pressure
428	-0.4 to +0.4 bar relative pressure
449	-1 to +1 bar relative pressure
452	0 to 0.4 bar relative pressure
454	0 to 1 bar relative pressure
457	0 to 4 bar relative pressure
459	0 to 10 bar relative pressure
461	0 to 25 bar relative pressure
463	0 to 60 bar relative pressure
464	0 to 100 bar relative pressure
481	-1 to +3 bar relative pressure
483	-1 to +9 bar relative pressure
485	-1 to +24 bar relative pressure
486	0 to 0.4 bar absolute pressure
488	0 to 1 bar absolute pressure
491	0 to 4 bar absolute pressure
493	0 to 10 bar absolute pressure
495	0 to 25 bar absolute pressure
506	0 to 60 bar absolute pressure
	(5) Output
459	IO-Link (default setting)/analog and digital (configurable)
470	1× PNP switching output ^a
471	2× PNP switching output ^a
475	1× PNP switching output 4 to 20 mA three-wire system ^a
477	1× PNP switching output 0 to 10 V three-wire system ^a
535	SPE with PoDL (Modbus TCP slave)
	(6) Process connection
504	G 1/2 DIN EN 837
511	1/4" – 18 NPT DIN EN 837
521	G 1/4 DIN 3852-11
523	G 1/2 DIN 3852-11
571	G 3/4 front-flush DIN EN ISO 228-1
574	G 1/2 front-flush with double seal
575	G 3/4 front-flush with double seal
576	G 1 front-flush with double seal
604	Taper socket with grooved union nut DN 25 according to DIN 11851 (dairy pipe fitting)
606	Taper socket with grooved union nut DN 40 according to DIN 11851 (dairy pipe fitting)
612	Clamping socket (clamp) DN 10, DN 15, DN 20, DIN 32676
613	Clamping socket (clamp) DN 25, DN 32, DN 40, DIN 32676
616	Clamping socket (clamp) DN 50 DIN 32676, 2", ISO 2852
652	Tank connection with grooved union nut, DN 25

997	JUMO PEKA (hygienic process connection)
(7)	Medium temperature
1	Standard
(8)	Electrical connection
36	Round plug M12 × 1
(9)	Measuring system filling medium
01	Silicone oil
12	FDA-compliant oil
(10)	Extra codes
000	None
374	Inspection certificate 3.1 Material DIN EN 10204
452	Parts in contact with media, electrolytically polished
591	Choke in the pressure channel
624	Oil and grease free
634	TAG number
769	Calibration certificate (only for version with analog output)
870	Inspection certificate 3.1 Surface roughness (Ra)
871	Inspection certificate 3.1 Accuracy DIN EN 10204 (only for version with analog output)

^a Pre-configured output 459

Order code (1) (2) (3) (4) (5) (6) (7) (8) (9) (10) , ...^a
 Order example 405056 / 0 - 7 - 427 - 535 - 997 - 1 - 36 - 01 / 000

^a List extra codes in sequence and separate using commas.

Accessories

Designation	Part no.
Line socket, 4-pole, M12 × 1, straight, length 2 m	00404585
Line socket, 4-pole, M12 × 1, angled, length 2 m	00409334
IO-Link master, 1-channel (TMG Device Tool), including mini USB cable for use with Windows® PC	00694070
IO-Link master, 4-channel – TURCK TBEN-S2-4IOL	00759867
IO-Link master, 8-channel – TURCK TBEN-LL-8IOL	00759875
Connection line M8/voltage supply, length 2 m, IO-Link master, 4 channel	00767913
Connection line M12/voltage supply, length 2 m, IO-Link master, 8 channel	00767914
Connection line M8/Ethernet, length 2 m, IO-Link master, 4 channel	00767923
Connection line M12/Ethernet, length 2 m, IO-Link master, 8 channel	00767927
Connection line M12, M12, black, PUR, length 2 m (straight coupling/straight connector; 5 pole; A-coded)	00777804

Further information and downloads



qr-405056-en.jumo.info

OneTemp[®]
 ptj ltd
 measure | control | record
1300 768 887
www.onetemp.com.au