

°C

%RH

SHIMADEN

Series SD16A & KR16

## SHIMADEN DIGITAL INDICATORS



CE approved, UL applied

**RoHS** compliance

### BASIC FEATURES

- DIN Size 48 x 96 mm**
- ± 0.3% High Accuracy Indication**
- Large 20 mm bright display**  
*Make reading from long distance and low light location easier*
- Multi-inputs & Multi-ranges**  
*User selectable Thermocouple, RTD, V, mV and Current inputs*  
*A 250Ω resistor is required across the input terminal for 4-20mA DC*
- Inverse scaling possible**  
*With voltage and current input signals, normal and inverse scaling is possible.*  
*Additionally, normal and inverse scaling is possible for the analog output signals.*
- Dust and splash proof front panel**  
*Equivalent to IP66*
- Wide range of optional features**  
*Alarms, analog output signals and communication interface (RS-232C or RS-485: MODBUS / Shimaden) available*  
*Sensor power supply 24V DC available*
- A six-point selector switch, (the KR16 series), is available for combined use.**

**Display**

- Digital display : Process value (PV) 7 segment Red LED 4 digits (H: 20mm)
- Action display : 1 point of parameter display (SET) by green LED
- Display accuracy : 1 point of communication display (COM) by green LED
- Display accuracy range : 2 points of alarm (AL1, AL2) by red LED
- Display resolution :  $\pm(0.3\% \text{ FS} + 1 \text{ digit})$  within measuring range
- Measured value display range : Excluding cold junction temperature compensation accuracy in the case of thermocouple input
- Display update cycle :  $\pm 5\% \text{ FS}$  for temperature below  $400^{\circ}\text{C}$  of thermocouple B
- : When the thermocouple [T, U] indication value is  $0\sim 100^{\circ}\text{C}$ ,  $0.5\% \text{ FS}$  and when it is below  $-100^{\circ}\text{C}$ ,  $1\% \text{ FS}$
- :  $23^{\circ}\text{C} \pm 5^{\circ}\text{C}$  ( $18\sim 28^{\circ}\text{C}$ )
- : Depends on measuring range (0.001, 0.01, 0.1, 1)
- :  $-10\sim 110\%$  of measuring range (Accuracy guaranteed for value is within measuring range only)
- : For R.T.D. input of  $-200\sim 600^{\circ}\text{C}$ :  $210\sim 680^{\circ}\text{C}$
- : For thermocouple [K] input of  $-199.9\sim 800^{\circ}\text{C}$ :  $-273.1\sim 900.0^{\circ}\text{C}$
- : 0.25~5.00 seconds configurable (0.25 seconds step)
- : When 0.5 second or more is set, there may occur a difference among the displayed value, the analog output and the communication data.

**Setting**

- Setting : By four (4) front key switches
- Setting range : Same as measuring range
- Setting protection : Keylock ON/OFF

**Input**

- Type of input : Three-type multiple input of Thermocouple, R.T.D., Voltage (mV, V)
- Thermocouple : B, R, S, K, E, J, T, N, {U, L (DIN 43710)}, WRe5-26  
Refer to measuring range code table
- External resistance :  $100\Omega$  max.
- Input impedance :  $500\text{K}\Omega$  max.
- Burnout : Standard (Up-scale)
- Cold junction temperature compensation accuracy :  $\pm 1^{\circ}\text{C}$  ( $18\sim 28^{\circ}\text{C}$  range)
- :  $\pm 2^{\circ}\text{C}$  ( $5\sim 18^{\circ}\text{C}$ ,  $28\sim 45^{\circ}\text{C}$  range)
- : ( $\pm 5^{\circ}\text{C}$  to the negative side of measuring range in case of T and U input)
- R.T.D. : JIS Pt100 $\Omega$  3-wire type
- Amperage : Approx. 0.25mA
- Lead wire tolerable resistance :  $5\Omega$  max. / wire (3 lead wire should have same resistance)
- : When the resistance value of each wire is same
- : 0~5 $\Omega$ :  $0.05^{\circ}\text{C}$ , 5~10 $\Omega$ :  $0.2^{\circ}\text{C}$ , 10~20 $\Omega$ :  $0.6^{\circ}\text{C}$ , 20~30 $\Omega$ :  $1.4^{\circ}\text{C}$  max.
- Voltage (mV) : 0~10mV DC
- Voltage (V) : 0~5V, 1~5V, 0~10V DC
- Input impedance :  $500\text{K}\Omega$  min.
- Current : 4~20mA DC
- Input impedance :  $250\Omega$  [A shunt resistor needs to be connected to the terminal]
- Input scaling function : Scaling possible for voltage (mV, V) or current (mA) input and inverse scaling possible.
- Scaling range : -1999~9999 unit
- Span : 10~10000 unit
- Position of decimal point : 1, 0.1, 0.01, 0.001
- Sampling cycle : 0.25 seconds
- PV bias : -1999~2000 unit
- PV filter : 0~100 seconds (0 = without filter)
- Isolation : Isolated between input and analog output (sensor power supply), or between input and communication.
- : Not isolated between input and system.

**Alarm output (option)**

- Number of alarm points : 2a (AL1 and AL2) for both normal open and common
- Alarm type : Selectable from combinations of the following 4 types
- : Higher limit absolute value (latching function)
- : Lower limit absolute value (latching function)
- Alarm setting range : Within measuring range or within full scaling range
- Alarm action : ON-OFF action
- Alarm sensitivity : 1~999 unit Within measuring range
- Alarm output / rating : Contact 1a (common) / 240V, AC1.5A (resistive load)
- Alarm output update cycle : 0.25 seconds

**Analog output (option) /****Not selectable with the sensor power supply**

- Analog output type : 0~10mV DC (output resistance: 10Ω)  
: 0~10V DC (load current: 1mA max.)  
: 4~20mA DC (load resistance: 300Ω max.)
- Output resolution : Approx. 1/14000
- Output accuracy : ±(0.3%FS + 1 digit) of display value
- Output scaling : Within measuring range or input scaling range (inverse scaling possible)
- Output update cycle : 0.25 seconds

**Communication (option)**

- Communication type : RS-232C, RS-485
- Communication system : Half duplex start-stop synchronized system
- Communication speed : 1200, 2400, 4800, 9600, 19200 bps
- Data bit length : 7 bit even parity 1 stop bit  
8 bit non parity 1 stop bit
- Data format : 7E1, 7E2, 7N1, 7N2, 8E1, 8E2, 8N1, 8N2
- Communication address : 1~100
- Multi-drop connection : 31 max. (with RS-485)
- Communication delay : 1~100 milli-seconds
- Communication protocol : Shimaden standard protocol, MODBUS ASCII, MODBUS RTU
- Communication code : Shimaden standard protocol: ASCII  
MODBUS ASCII: ASCII  
MODBUS RTU: binary
- Others : Start character and BCC operation method can be selected for Shimaden standard protocol.

**Sensor power supply (option)**

- Output rating : 24V±3V DC 25mA max.
- ON/OFF : Depending upon instrument's power ON-OFF status.
- Restrictions : Sensor power supply can't be selected when the analog output is selected.  
Sensor power supply can't be selected when the power supply 24V is selected.

**Others**

- Data storage : By non volatile memory (EEPROM)
- Ambient conditions for use : -10~50°C/90%RH max. (on condition that there is no dew condition)
- Height : 2000m above sea level or lower
- Installation category : Category II
- Degree of pollution : Degree 2
- Power supply voltage : 100~240V AC±10%, 50/60Hz  
24V AC (50/60Hz) /DC±10% (option)
- Power consumption : 11VA (100~240V AC), 7VA (24V AC), 5W (24V DC)
- Applicable standard : IEC61010-1, EN61010-1
- Safety : EN61326:1997+A1:1998, A2:2001, A3:2003
- EMC : EMC testing display accuracy ±3%FS
- Dust proof/Drip proof : IP66 (Complies with the IEC 529-IP66)
- Insulation resistance : Between input/output terminal and power supply terminal:  
500V DC 20MΩ minimum  
: Between input/output terminal and protective conductor terminal  
500V DC 20MΩ minimum
- Dielectric strength : Between all input/output terminals and power terminal:  
2300V AC for one minute (faradic current 1mA)  
: Between power terminal and ground terminal:  
1500V AC for one minute (faradic current 1mA)
- Case material : PPO resin molding (equivalent to UL94V-1)
- External dimensions : H48 x W96 x D110 mm
- Mounting : Push-in panel (one-touch mount)
- Panel thickness : 1.0~4.0 mm
- Panel cutout : H45 x W92 mm
- Weight : Approx. 250g

**Selector KR16 series**

- No. of switching points : 6
- No. of switching circuits : 2
- Switching operation method : Push button switching
- Applicable signal contact rating : DC voltage, current (R.T.D.is not applicable)
- Contact method : Contact slide
- Voltage : 30V DC max.
- Current : 100mA DC max.
- Contact resistance : 300m Ω max.
- Operating ambient temperature range : -10~50°C
- Operating ambient humidity range : 90% RH max.
- Material : PPO resin
- Color : Case : Munsell No. N-1 or compatible  
Front Panel: Munsell No. N-1 or compatible
- External dimensions : H48 x W96 x D118 (panel depth: 100) mm
- Panel cutout : H45 x W92 mm
- Mounting : Push-in panel (one-touch mount)
- Panel thickness : 1.0~4.0 mm
- Weight : Approx. 250g

**APPLICATION EXAMPLE**

**1. Selection of T. C. Switching**

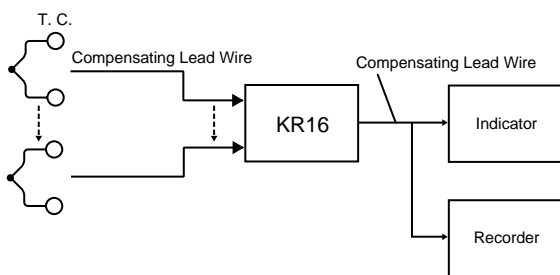

**2. Selection of Voltage Switching**

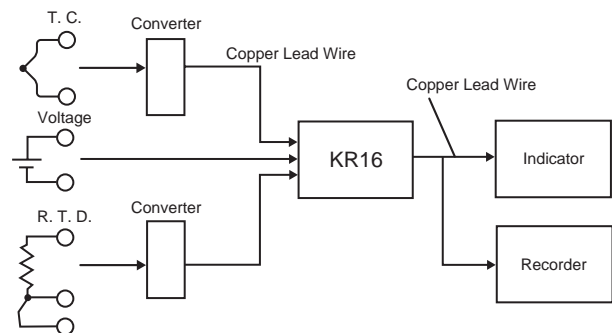

**3. Selection of Analog Output (Voltage)**

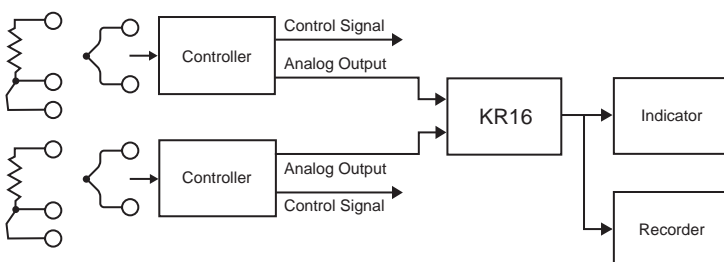

**4. Installation Example With SD16A**

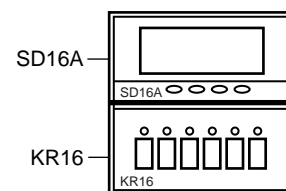

## ORDERING INFORMATION

Series **SD16A**

ITEM	CODE		SPECIFICATIONS
1	SERIES	SD16A-	Digital Indicator DIN Size 48 × 96 mm
2	INPUT	4	Current (4~20mA DC) Applied via enclosed 250Ω shunt resistor
		8	*Thermocouple B, R, S, K, E, J, T, N, {U, L (DIN 43710)} Multi input *R.T.D. Pt100Ω / JPt100Ω *Voltage (mV, V) 0~10mV DC, 0~5V DC, 0~10V DC, 1~5V DC
3	POWER SUPPLY	90-	100~240V AC±10% (50/60Hz)
		08-	24V AC ±10% (50/60Hz) / 24V DC ±10% (Note:2)
4	ALARM OUTPUT (OPTION)	0	None
		1	Individual setting, individual output 2 points (a contact) Contact capacity: 250V AC 1.5A / resistive load
5	ANALOG OUTPUT (OPTION) OR SENSOR POWER SUPPLY (Note:2)	0	None
		3	0~10mV DC Output resistance: 10Ω
		4	4~20mA DC Load resistance: 300Ω max.
		6	0~10V DC Load resistance: 1mA max.
		8	Sensor power supply 24V DC 25mA max. (Note:2)
6	COMMUNICATION FUNCTION (OPTION)	0	None
		5	RS-485 Shimaden standard protocol/MODBUS (RTU/ASCII) communication protocol
		7	RS-232C Shimaden standard protocol/MODBUS (RTU/ASCII) communication protocol
7	REMARKS	0	Without
		9	With (Please consult before ordering)

Notes:

- Scaling range: -1999~9999 unit, Span: 10~10000 unit
- The sensor power supply may not be used when you select the Power Supply Code 08 (24V AC/DC).

## MEASURING RANGE CODES

INPUT	TYPE	CODE	RANGE (°C)	RANGE (°F)
THERMOCOUPLE	B	01	0 ~ 1800	0 ~ 3300
	R	02	0 ~ 1700	0 ~ 3100
	S	03	0 ~ 1700	0 ~ 3100
	K	04	-199.9 ~ 800.0	-300 ~ 1500
	K	05	0 ~ 1200	0 ~ 2200
	E	06	0 ~ 700	0 ~ 1300
	J	07	0 ~ 600	0 ~ 1100
	T	08	-199.9 ~ 300.0	-300 ~ 600
	N	09	0 ~ 1300	0 ~ 2300
	*1 U	10	-199.9 ~ 300.0	-300 ~ 600
	*1 L	11	0 ~ 600	0 ~ 1100
	*2 WRe5-26	12	0 ~ 2300	0 ~ 4200
R.T.D.	Pt	31	-199.9 ~ 600.0	-300 ~ 1100
		32	-100.0 ~ 100.0	-150.0 ~ 200.0
	JPt	* 33	-199.9 ~ 500.0	-300 ~ 1000
		* 34	-100.0 ~ 100.0	-150.0 ~ 200.0
VOLTAGE	0~10mV	71	Initial value: 0.0~100.0 Scaling possible (Inverse scaling possible)	Thermocouple B, R, S, K, E, J, T, N: JIS/ANSI/IEC *1 Thermocouple U, L: DIN 43710 *2 Thermocouple WRe5-26: Made of Hoskins
	0~ 5V	81		
	1~ 5V	82		
CURRENT	0~10V	83	Scaling setting range: -1999~9999 Span: 10~10000 unit	
	4~20mA	95		

Factory Setting:

Universal-Input K: 0~1200°C  
 Current Input 4~20mA 0.0~100.0 (Without unit)  
 Thermocouple T, U: Accuracy = ±0.5%FS for -100~0°C  
 ±1%FS for -100°C or less  
 Thermocouple B: Accuracy = ±5%FS for 400°C or less

\* Scaleover occurs at -240.0°C at Pt (Code 31) or JPt (Code 33).

Any decimal position shown in the measuring ranges of thermocouple and R.T.D. inputs may be concealed.

## ORDERING INFORMATION

Series **KR16**

ITEM	CODE		SPECIFICATIONS
1	SERIES	KR16-	Push button six-point selector
2	REMARKS	0	Without
		9	With (Please consult before ordering)

### • SD16A

#### External Dimensions

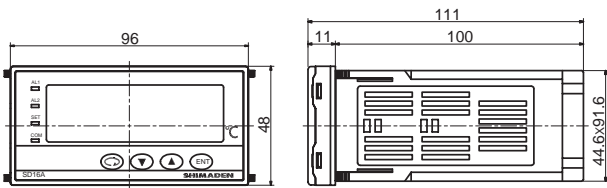

#### Panel Cutout

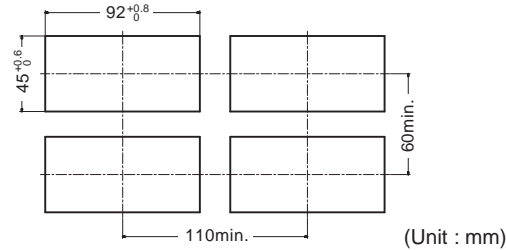

#### Terminal Arrangement

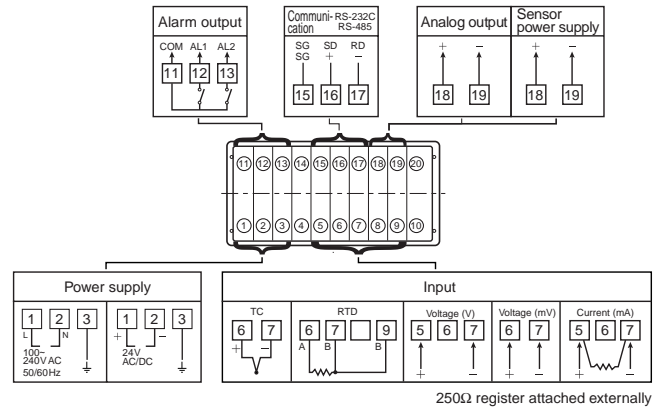

### • KR16

#### External Dimensions

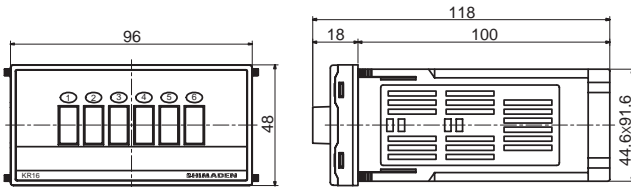

#### Panel Cutout

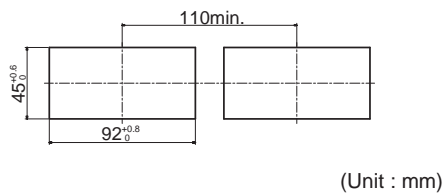

#### Terminal Arrangement

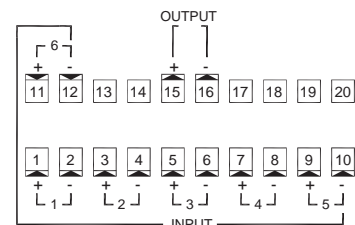

#### Panel Cutout

In case installed with SD16A

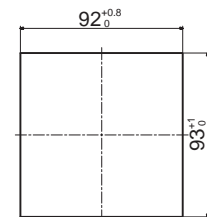

(Unit : mm)

#### ⚠ Warning

- The SD16A & KR16 series is designed for the control of temperature, humidity and other physical values of general industrial equipment. (It is not to be used for any purpose which regulates the prevention of serious effects on human life or safety.)

#### ⚠ Caution

- If the possibility of loss or damage to your system or property as a result of failure of any part of the process exists, proper safety measures must be made before the instrument is put into use so as to prevent the occurrence of trouble.

ISO 9001

ISO 14001



(The contents of this brochure are subject to change without notice.)

Temperature and Humidity Control Specialists

# SHIMADEN CO., LTD.

Head Office: 2-30-10 Kitamachi, Nerima-Ku, Tokyo 179-0081 Japan  
 Phone: +81-3-3931-7891 Fax: +81-3-3931-3089  
 E-MAIL: exp-dept@shimaden.co.jp URL: http://www.shimaden.co.jp